

THE FREQUENCY DEPENDENT RESPONSE OF THE ELECTRICAL IMPEDANCE OF UO_2

R.N. HAMPTON, G.A. SAUNDERS

School of Physics, University of Bath, Claverton Down, Bath, BA2 7AY, United Kingdom

and

A.M. STONEHAM

Theoretical Physics Division, A.E.R.E. Harwell, Didcot, Oxon, OX11 0RA, United Kingdom

Received 17 February 1986; accepted 5 March 1986

AC impedance techniques in the frequency range 5 Hz to 5 MHz have been employed to measure dielectric properties of single crystal UO_2 in the form of plate specimens. The dielectric constant has been measured down to 4 K, giving results consistent with previous reports. Both barrier and volume effects have been shown to contribute to the measured impedances. The barrier effects account for the anomalously large capacitances observed in previous attempts to measure the dielectric constant by the conventional plate technique. Activation energies for carriers in both boundary and bulk regions are similar (0.18 to 0.25 eV). The behaviour is consistent with the presence of electronic holes present in the concentrations to be expected from small deviations from stoichiometry.

1. Introduction

The static dielectric constant ϵ_{st} of UO_2 has been measured by a number of workers [1–6]. Typical values of ϵ_{st} (24 [1] and 21.5 [5]) obtained from optical measurements are confirmed by recent microwave measurement (21 [6]). However, the conductivity of UO_2 lies in such a range that ac bridge measurements made on a standard sample in the form of two parallel conducting plates with UO_2 as the dielectric medium give rise to an anomalously large capacitance and hence an unrealistically large value of ϵ_{st} [1,4]. As the temperature is reduced the impedance changes in such a way that the measured ϵ_{st} tends towards the accepted value of about 21; increasing the bridge measurement frequency has the same effect [4]. In the previous work [4] on the response of UO_2 to an ac electric field only a limited number of frequencies were available. Impedance measurements have now been extended to cover a much wider frequency range. This has enabled us to tap a much greater body of data for the frequency dependent response of UO_2 when in the form of plate samples. This data is extensive enough to allow detailed analysis by projection onto the complex impedance plane. Details of the procedures adopted are given in ref. [7];

previously such techniques have been successfully used [8] in studies of the ac electrical properties of yttria-stabilised zirconia.

2. Experimental

The ac impedance measurements have been made in the frequency range 5 Hz to 5 MHz on UO_2 single crystals in the form of thin discs with opposing faces aluminium coated to form the electrodes [4]. Nominal stoichiometry was attained by reduction of the crystals (supplied by Degussa and Norton Research) at 1400°C in an atmosphere of dry hydrogen for 12 h. Typical impedance data are presented in fig. 1 at three of the temperatures at which measurements have been made. In general the data projected onto the complex impedance plane evidence a clear division into two separate curved regions. This implies the existence of two different regimes, each characterised by a resistance R and a capacitance C . The form of the results complies with that expected for the effective parallel capacitance and resistance of the series-parallel combination shown in fig. 2a in the limit of widely differing time constants for each parallel element i.e. $1/C_b R_b \gg 1/C_v R_v$. Region 2

is normally attributed to a thin barrier layer, which is characterized by high values of capacitance and resistance. Region 1 represents the bulk properties of the sample having the larger time constant due to a more conducting nature and the larger dimensions of the bulk of the crystal itself. The logarithmic representation of the complex impedance plot anticipated for the equivalent circuit in figure 2a is sketched in fig. 2b. This illustrates the features which enable extraction of the capacitance and resistance values corresponding to the barrier and volume circuit elements. In the present study complex impedance plots of the type given in fig. 1 have been measured at temperatures between 100 K and 300 K and preliminary measurements have been made at 4.2 K. Values of the two capacitances C_b and C_v calculated from these data are shown in fig. 3. Above about 200 K in the frequency range studied the impedance is dominated by the barrier element alone and the capacitance obtained cannot be regarded as representing the dielectric properties of the UO_2 crystal. Below about 200 K the region due to the volume effect also comes into play so that the volume capacitance can also be obtained. These results are consistent with a dielectric constant ϵ_{st} of 36, somewhat larger than that (in the range of 20) obtained by microwave [6] or optical [1,5] measurements. However the frequency response method described here has now been extended

down to low temperature measurements and does give a value of 24 for ϵ_{st} at 4.2 K and at 77 K. The difference ($\Delta\epsilon_{st} \sim 12$) between the values obtained for ϵ_{st} at 150 K and above and 77 K may be attributable to dipole orientational effects becoming less important with decreasing temperature. On the basis of the Clausius-Mosotti approach (including a local field correction), for dipoles comprised of a hole and an oxygen interstitial, a deviation from stoichiometry at most of about 0.005 would be sufficient to lead to a dipolar contribution large enough to account for the measured difference $\Delta\epsilon_{st}$. Such a deviation is well within the limits of the possible range of oxygen concentration in the UO_2 crystals used to make the measurements. Low temperature (< 80 K) dielectric measurements have not been made on the Norton crystal, so an estimate of the excess stoichiometry for this crystal is not available.

Measurement of the dependence of the barrier capacitance C_b upon the voltage V_b applied across the barrier enables the barrier properties to be investigated further. The technique used has been to plot dV_b/dC_b^{-2} against $\epsilon_0\epsilon_r/C_b$, following the method used previously to analyse barrier contributions to the conductivity of rutile and hence find the barrier thickness [9]. In the present instance, the barrier thickness of a UO_2 crystal at 291 K has been estimated as being about 600 Å. To find out whether the effects observed are due to the

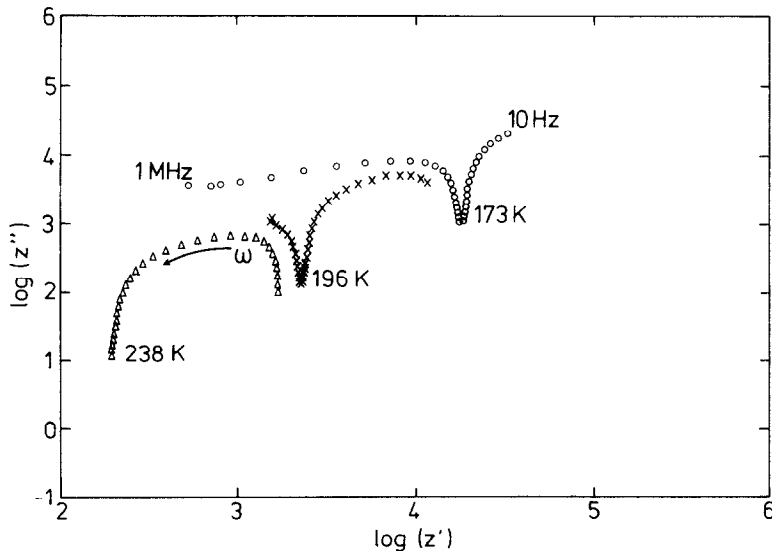
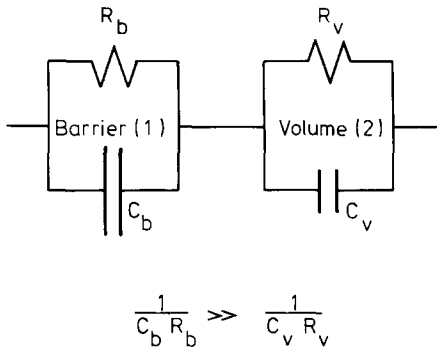

Fig. 1. Logarithmic plots of impedance data obtained on a disc-shaped specimen ($A/L = 0.21$ m) of monocrystalline (Norton) UO_2 in the frequency range 10 Hz to 1 MHz at selected measurement temperatures using a driving voltage of 0.5 V.



particular electrodes (aluminium) employed, tests have been made with coatings of silver paint and platinum; the large capacitance values associated here with the barrier have also been found using these materials. The high values obtained previously [4] when the dielectric constant of UO₂ was tentatively assessed from capacitance measurements made at low frequencies and temperatures above 200 K can now be associated with the barrier effect and the low temperature limits found then for ϵ_{st} of 25.3 for a UO₂ single crystal and 22.8 for polycrystalline UO₂ to the bulk material itself. Thus the anomalous frequency dependences inferred [4] for the conduction mechanisms and dielectric behaviour of UO₂ have now been resolved.

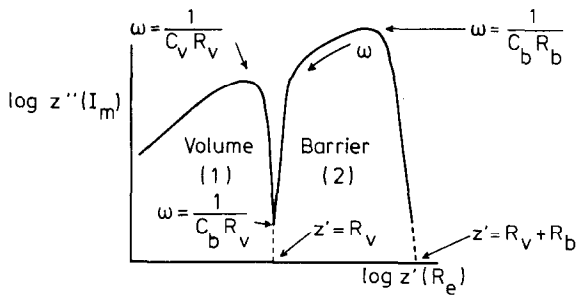

Fig. 2. (a, top) The two region series-parallel combination of resistances R and capacitances C employed as the model for processing impedance data of the type illustrated in fig. 1. (b, bottom) A schematic representation in the complex logarithmic impedance plane of the theoretical behaviour expected for the equivalent circuit of fig. 2a. The features used to extract the corresponding component values for each of the two regions are shown.

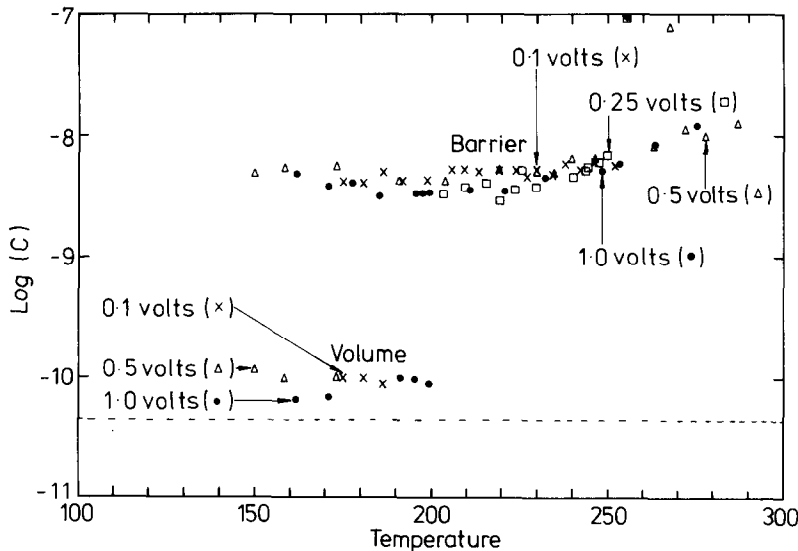

Fig. 3. The capacitances of the two regions extracted from complex impedance plots for a plate specimen ($A/L = 0.21$ m) of monocrystalline (Norton) UO₂ obtained for a range of driving voltages ($\times \equiv 0.1$ V, $\square \equiv 0.5$ V, $\Delta \equiv 0.25$ V and $\bullet \equiv 1.0$ V). The capacitance separates clearly into two regions, ascribed to barrier and volume effects, the latter being reasonably close to the capacitance that would result with the dielectric constant value ϵ_{st} ($= 24$) quoted in ref. [1].

3. Analysis

It is usual practice to interpret conductivity data for UO_2 by using Arrhenius plots. The conductivity, measured for this sample geometry in the volume region [2] is given in this format in fig. 4. The use of the impedance plane technique allows the conductivity data to be fitted readily to both models currently employed to evaluate the possible conduction processes in UO_2 , namely (i) band conduction (eq. 1) and (ii) small polaron conduction (eq. 2):

$$\ln \sigma = \ln \sigma_0 - E_A/kT, \quad (1)$$

$$\ln(\sigma T) = \ln \sigma'_0 - E'_A/kT. \quad (2)$$

The activation energies (E_A and E'_A) and pre-factors (σ_0 and σ'_0), obtained by a least squares analysis, are given in table 1. One of the single crystals studied was that supplied by Norton Research; it is much more friable, and this has been attributed to a more defective structure than the other crystal (from Degussa). This more defective nature is supported by the order of magnitude difference in the pre-factors, both σ_0 and σ'_0 , for the two crystals, which is considered not to be due to stoichiometric differences. The activation energies obtained for the volume region are somewhat larger than those reported by several earlier workers (0.17 eV [10], 0.14 eV [11], 0.13 eV [12]) but are comparable to that (0.22 eV) obtained [4] at lower temperatures where

the volume effect has now been shown to dominate. The activation energy (0.178 ± 0.015 eV) for conduction in the barrier region is smaller than that in the volume; however, the finding that it is comparable in magnitude to that in the bulk is instructive, in that it indicates that the barrier is in fact comprised of UO_2 but that its properties are modified (possibly by space charge in the vicinity of the metallic electrodes). Experimental evidence for this viewpoint comes directly from values obtained for the equivalent circuit components. A typical example can be taken from the results in fig. 1; at 238 K the volume resistance for this particular crystal (thickness 0.5 mm) is 203Ω while the barrier resistance is 153Ω ; the resistances of the two regions are comparable in magnitude. Fig. 5 presents the Arrhenius plot as $\ln(1/R_b)$ versus $1/T$ for the resistance measured for the barrier region. For this region the resistance depends also upon the applied ac voltage, an effect which is characteristic of a poorly conducting, highly capacitive barrier region [7] and provides additional experimental evidence for the identification of the two regions observed in the impedance profiles. As might be expected no driving voltage dependence is observed to be associated with the conductivity of the bulk region. Furthermore the gradient of the high frequency end of the volume profile (as exemplified by the 173 K profile in fig. 1) is 0.5, showing that the circular impedance arc passes through the origin on a conventional Z' versus

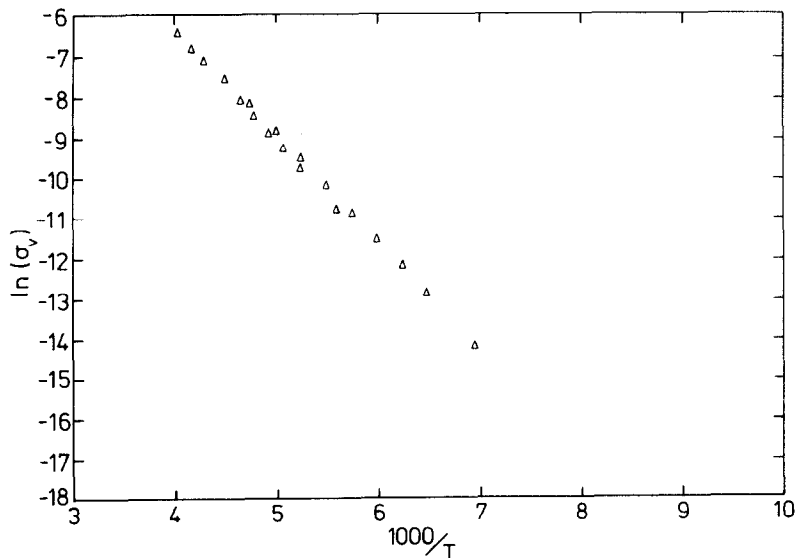

Fig. 4. Arrhenius-format plot of the conductivity σ_v associated with the bulk effect of monocrystalline (Norton) UO_2 and calculated from R_v obtained from the complex impedance plots for a driving voltage of 1.0 V.

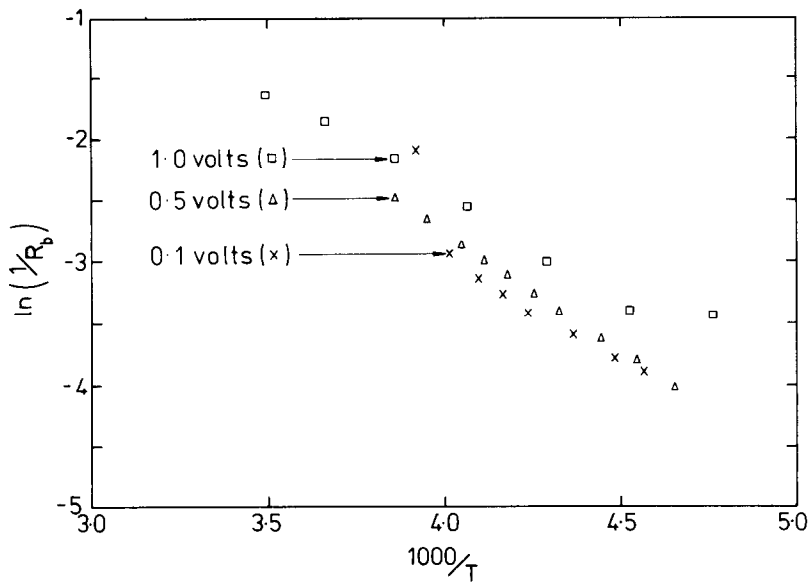

Fig. 5. The barrier resistance of a plate specimen of monocrystalline (Norton) UO_2 plotted as $\ln(1/R_b)$ against $1/T$ to enable determination of the activation energy. The barrier R_b depends upon the driving voltage ($\times \equiv 0.1$ V, $\Delta \equiv 0.5$ V, $\square \equiv 1.0$ V).

Z'' graph, as it should [7] for the model in fig. 2. Hence the volume circuit may be expected to represent fully the electrical response up to the high frequency limit.

The identification of a barrier associated with dielectric constant measurements now raises the question of possible effects on conductivity data. It is interesting to note that the accepted high temperature conductivity data of Bates [10] and Killeen [11] have been measured at either dc or at low frequencies (0.005–5 kHz). Such measurements would be well within the barrier dominated regime at temperature of 300 K or above:

even for the four-probe methods used, the existence of a barrier might influence resistivity measurements.

Acknowledgements

We are grateful to Dr. J.E. Macdonald for many useful discussions and to Dr. M.T. Hutchings for supplying the single crystals. This work was supported under an E.M.R. contract with A.E.R.E., Harwell.

Table 1
Activation energies and Arrhenius equation prefactors for UO_2 single crystals

	Crystal supplier	Pre-factor ($\Omega^{-1}m^{-1}$)	Activation energy (eV)
Band Conduction } Small Polaron }	NR ^a	34.6 ± 4.6	0.228 ± 0.003
	D ^b	2.85 ± 0.14	
Small Polaron }	NR ^a	6844 ± 881	0.246 ± 0.003
	D ^b	572 ± 40	
$\ln(1/R_b)$ vs. $1/T$	NR ^a	-	0.262 ± 0.002
			0.178 ± 0.015

^a Single crystal supplied by Norton Research.

^b Single crystal supplied by Degussa.

References

- [1] J.D. Axe and G.D. Pettit, *Phys. Rev.* 151 (1966) 676.
- [2] S. Iida, *Jap. J. Phys.* 4 (1965) 833–838.
- [3] W. Hayes and A.M. Stoneham, *Crystals with the Fluorite Structure*. Ed. W. Hayes (Clarendon Press, Oxford, 1974) Chap. 2, p. 43.
- [4] N. Hampton, E.A. Saunders, G.A. Saunders, D. Vigar and A.M. Stoneham, *J. Nucl. Mater.* 132 (1985) 156–159.
- [5] J. Schoenes, *Phys. Reports* 63 (1980) 301–336.
- [6] J. Tateno, *J. Chem. Phys.* 81 (1984) 6130–6135.
- [7] A.K. Jonscher, *Dielectric Relaxation in Solids* (Chelsea Dielectrics Press, Chelsea, 1983) p. 62–86.
- [8] P. Abelard and J.F. Baumard, *Phys. Rev.* B62 (1982) 1005–1017.
- [9] F. English and B. Gossick, *Solid-State Electron.* 7 (1964) 193–204.
- [10] J.L. Bates, C.A. Hinman and T. Kawada, *J. Am. Ceram. Soc.* 50 (1967) 652–656.
- [11] J.C. Killeen, *J. Nucl. Mater.* 88 (1980) 185.
- [12] Z.A. Munir, *Int. J. Thermophys.* 2 (1981) 177.