



Contents lists available at ScienceDirect

Nuclear Instruments and Methods in Physics Research A

journal homepage: www.elsevier.com/locate/nima

The TORCH time-of-flight detector



N. Harnew^{a,*}, N. Brook^d, L. Castillo García^{c,e}, D. Cussans^b, K. Föhl^c, R. Forty^c, C. Frei^c,
R. Gao^a, T. Gys^c, D. Piedigrossi^c, J. Rademacker^b, A. Ros Garcia^b, M. van Dijk^b

^a University of Oxford, Denys Wilkinson Building, 1 Keble Road, Oxford OX1 3RH, UK

^b H.H. Wills Physics Laboratory, University of Bristol, Bristol BS8 1TL, UK

^c CERN, PH Department, CH-1211 Geneva 23, Switzerland

^d University College London, Department of Physics & Astronomy, Gower Street, London WC1E 6BT, UK

^e Laboratory for High Energy Physics, Ecole Polytechnique Fédérale de Lausanne, CH-1015 Lausanne, Switzerland

ARTICLE INFO

Article history:

Received 18 June 2015

Received in revised form

9 November 2015

Accepted 10 November 2015

Available online 2 December 2015

Keywords:

Particle identification

Cherenkov radiation

Time of Flight

Micro-Channel Plate Photomultiplier

MCP detector

ABSTRACT

The TORCH time-of-flight detector is being developed to provide particle identification between 2 and 10 GeV/c momentum over a flight distance of 10 m. TORCH is designed for large-area coverage, up to 30 m², and has a DIRC-like construction. The goal is to achieve a 15 ps time-of-flight resolution per incident particle by combining arrival times from multiple Cherenkov photons produced within quartz radiator plates of 10 mm thickness. A four-year R&D programme is underway with an industrial partner (Photek, UK) to produce 53 × 53 mm² Micro-Channel Plate (MCP) detectors for the TORCH application. The MCP-PMT will provide a timing accuracy of 40 ps per photon and it will have a lifetime of up to at least 5 Ccm⁻² of integrated anode charge by utilizing an Atomic Layer Deposition (ALD) coating. The MCP will be read out using charge division with customised electronics incorporating the NINO chipset. Laboratory results on prototype MCPs are presented. The construction of a prototype TORCH module and its simulated performance are also described.

© 2015 The Authors. Published by Elsevier B.V. This is an open access article under the CC BY license (<http://creativecommons.org/licenses/by/4.0/>).

1. Introduction

The (TORCH Time Of internally Reflected Cherenkov light) detector [1] is an R&D project to develop a large-area time-of-flight (ToF) system, up to around 30 m². TORCH combines timing information with Detection of Internally Reflected Cherenkov light (DIRC)-type reconstruction, aiming to achieve a ToF resolution of approximately 10–15 ps per track.

A schematic of the TORCH module is shown in Fig. 1. Cherenkov light production is prompt, hence a plane of 10 mm thick quartz is used as the source of a fast signal. Cherenkov photons travel to the periphery of the detector by total internal reflection and their angles (positions) and arrival times are measured with Micro-Channel Plate PMTs (MCPs). Simulation has shown that a 1 mrad angular resolution is required [2] and, to achieve this, 128 × 8 granularity MCPs of 53 × 53 mm² active area are being developed.

One of the applications of TORCH is for the upgraded LHCb experiment [3]. The aim is to achieve positive identification of kaons up to ~10 GeV/c following removal of the aerogel in the current RICH-1 detector [4]. At this momentum the time of flight

difference between a π and K is 35 ps over a ~10 m flight path, hence a ~15 ps time resolution per track is required for a 3σ separation. Assuming ~30 detected photoelectrons over an active area of 30 m², the timing of single photons to a precision of 70 ps is required.

2. Principles of operation

In the TORCH detector, precise timing is achieved by correcting for the chromatic dispersion of the radiator material, a concept previously developed by the Belle TOP [5] and the PANDA DIRC [6] collaborations. The technique relies on the measurement of the Cherenkov angle θ_c and the arrival time of the photon at the periphery of a quartz radiator bar (for wavelengths in the range $E_\gamma = 3 - 5$ eV, the spread in Cherenkov angles is $\Delta\theta_c \sim 24$ mrad, considerably larger than the 1 mrad angular requirement). From the θ_c measurement, the path length L of the photon after multiple internal reflections can be reconstructed. The time of propagation of the photon can then be determined from L and the group velocity in the quartz, inferred via the dispersion relation.

The ~1 mrad angular precision is required in both planes, namely in θ_z (the angle with respect to the vertical direction) and

* Corresponding author.

E-mail address: Neville.Harnew@physics.ox.ac.uk (N. Harnew).

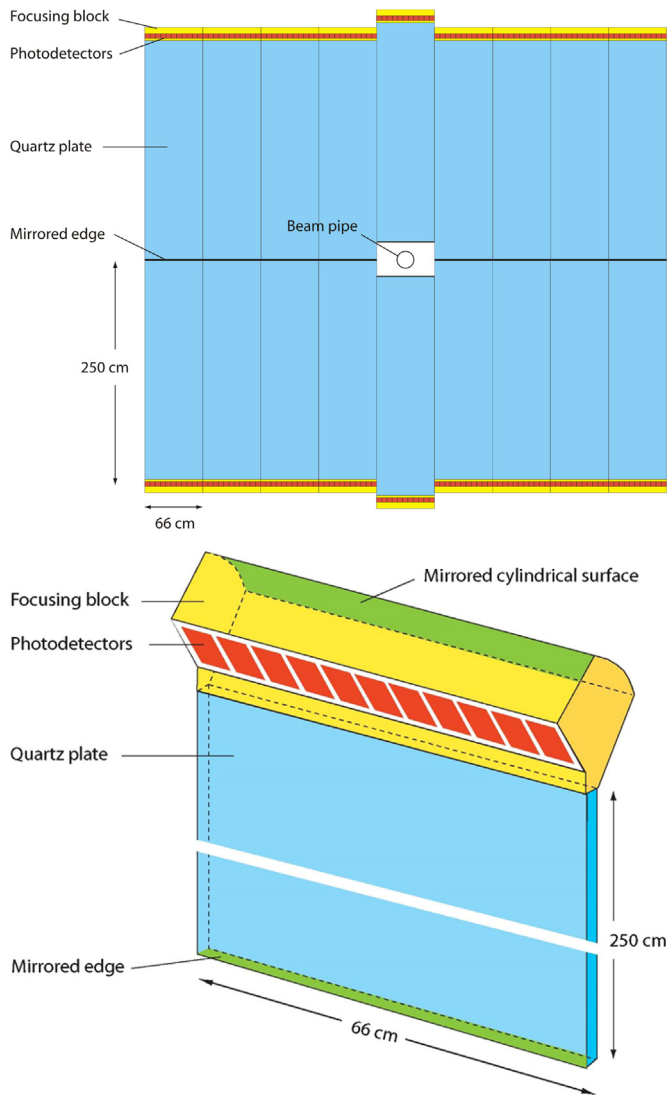

Fig. 1. Schematics of (upper) the TORCH detector, and (lower) a TORCH module.

in θ_x (the azimuthal angle in the plane of the quartz front surface). TORCH uses a quartz focusing block, shown in Fig. 2, to convert θ_z into a position on the photon detector plane, and for this good spatial accuracy is required. For the θ_x angular measurement, the longer lever arm requires only coarse precision. Hence we require an MCP-PMT which provides a spatial resolution of 0.4 mm and 6 mm respectively in the two dimensions. For this, 128×8 pixels of an MCP of $53 \times 53 \text{ mm}^2$ (a standard “2 in.”) active dimension is required.

3. MCP development

MCP photon detectors are well known for fast timing of single photon signals ($\sim 20 \text{ ps}$). Additional requirements for TORCH photodetectors also include good lifetime ($> 5 \text{ C cm}^{-2}$) and fine granularity. The highest MCP granularity currently commercially available is the 32×32 1.6 mm-pitch Planacon from Photonis.¹ The anode pad structure can in principle be adjusted according to the

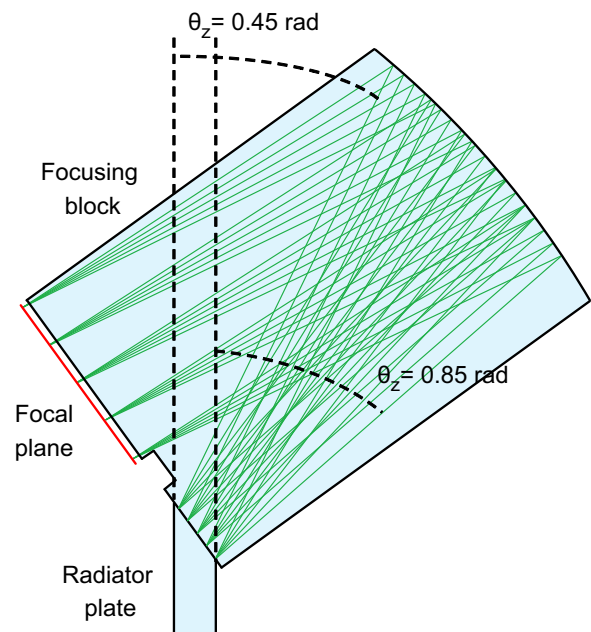

Fig. 2. The TORCH focussing block, showing the range of angles θ_z .

required resolution (in our case 128×8) provided the charge footprint is small enough.

A major TORCH focus is to develop a customised MCP with an industrial partner, namely Photek (UK).² Three phases of R&D have been defined. Phase 1 has been completed and involved the fabrication of a set of single-channel MCPs with extended lifetime and $\sim 30 \text{ ps}$ timing resolution. Phase 2 MCPs have customised granularity (128×8 pixels equivalent) and are currently under test. Phase 3 tubes will follow in around 9 months and are 2-in. square with high active area ($> 80\%$), with the required lifetime, granularity and time resolution. These MCPs are in preparation. Photographs of the Photek Phase 1 and Phase 2 tubes are shown in Fig. 3.

Up to quite recently, poor MCP tube lifetime was an issue [7], with severe loss of quantum efficiency with exposures to photon doses significantly below 1 C cm^{-2} . The breakthrough in technology has been the use of Atomic Layer Deposition (ALD) techniques to coat the MCP surface [8]. The normalized photocathode current, shown in Fig. 4 for a Photek tube [9], shows that the uncoated MCPs are significantly out-performed by the ALD-coated MCPs for lifetime (the latter being good to beyond 5 C cm^{-2}). In a parallel activity, TORCH long-term lifetime testing is also underway.

Traditional multi-anode manufacturing of MCPs uses multiple output pins. This is too dense for a 128-column structure, the plan for TORCH is therefore to reduce the size to 64×64 with pixel pads of dimension 0.75 mm wide on a 0.88 mm pitch. Phase 2 tubes have 32×32 pixels of this same geometrical construction (i.e. 1/4 size) in a circular tube, and to achieve 64×8 , eight pixels are ganged together in the coarse direction. Charge sharing between pads then recovers the pixel resolution from 64 to 128 pixels equivalent and also halves the total number of readout channels. Also, a novel method is used to couple the MCP-PMT output pads to the readout PCB through an Anisotropic Conductive Film (ACF).

¹ Photonis USA, Lancaster, PA 17601-5688, USA.

² Photek Ltd., St. Leonards-on-Sea, TN38 9NS, United Kingdom.

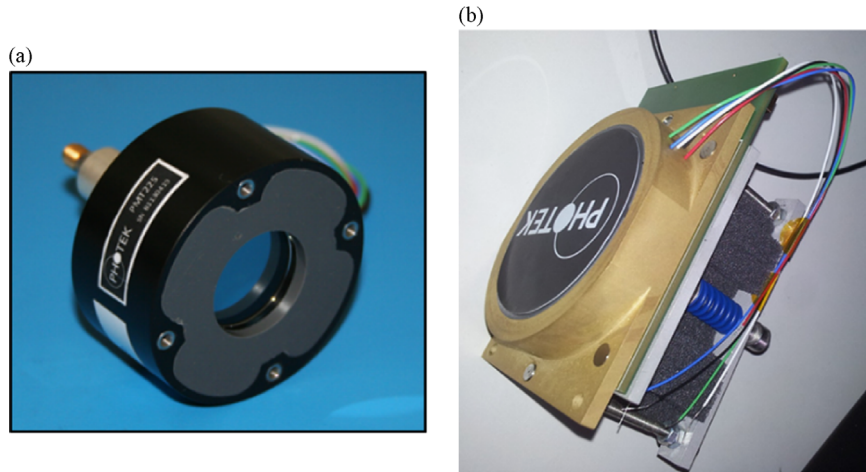

Fig. 3. Photographs of the Photek: (a) Phase 1 and (b) the Phase 2 MCP-PMTs.

4. Readout electronics

The readout electronics are a critical component for achieving the desired timing and spatial resolution of the TORCH detector. A suitable front-end chipset has been developed for the ALICE ToF system. TORCH uses 32-channel NINOs [10], with 64 channels per board, which incorporates time-over-threshold information. This is used to correct time-walk and provide the charge measurement. The NINO is used in conjunction with the HPTDC chip [11] to digitize the time measurement. A photograph of the TORCH readout system is shown in Fig. 5, showing four independent customized boards.

5. Laboratory performance studies

Photek Phase 1 MCP detectors have been characterised in the laboratory to demonstrate lifetime and timing resolution performance. Phase 2 MCPs are currently being tested for their timing and charge sharing characteristics.

5.1. Timing

The single-photon timing resolutions achieved with Photek Phase 1 and Phase 2 tubes are shown in Fig. 6. For the Phase 1 tube, the timing resolution is measured with a fast laser and with commercial electronics [12], and an excellent resolution of 23 ps is achieved, shown by the main peak. An additional shoulder is observed to the right due to a secondary laser pulse. Back-scattered photoelectrons also populate the main peak and contribute to some observed asymmetry. A Phase 2 Photek tube has also been tested for its timing resolution with a fast laser. In this case the commercial electronics have been replaced with the customised NINO-32 and HPTDC system with the HPTDC time binning set to 100 ps, which is $4 \times$ the optimal value of 25 ns for this device. A preliminary result of 85 ps is achieved for the timing resolution after corrections have been made for time-walk effects from the time-over-threshold information from the NINO and the integral non-linearity (INL) of the HPTDC.

5.2. Spatial resolution

Tests of charge sharing between pixels of the Phase 2 tube are in progress. A pulsed 405 nm laser is attenuated to give single

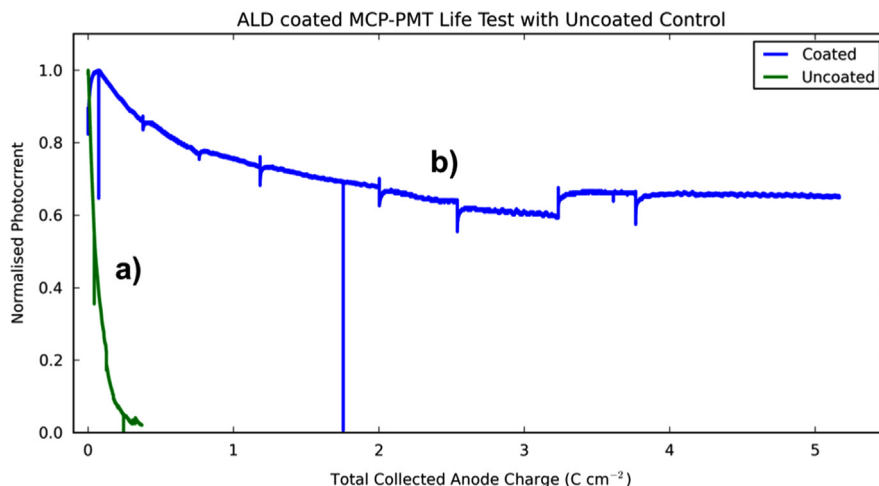

Fig. 4. Photocathode current as a function of wavelength and illumination for a Photek MCP [9]; curve (a) without ALD, curve (b) with ALD.

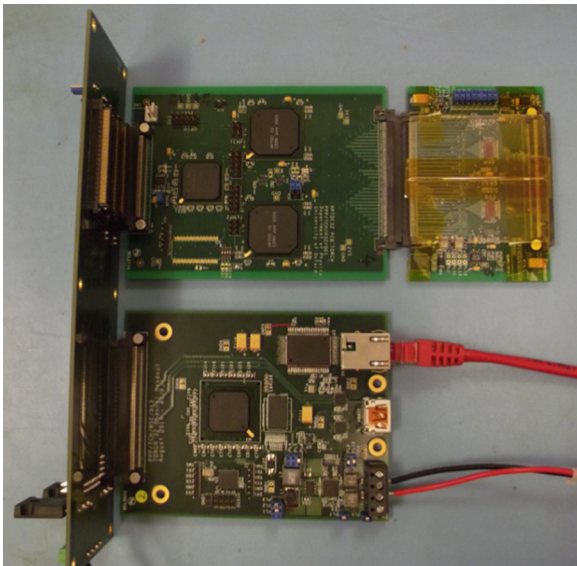

Fig. 5. A photograph of the TORCH readout system. The 64-channel NINO board is in the upper right which receives the raw MCP signals. The NINO board is connected to the HPTDC board, which gives 64 channels in 100 ps time-bin mode. A customised backplane arranged at 90° connects the HPTDC board to the readout board, which is at the bottom of the figure. This connects to a data acquisition PC via ethernet.

photons and is fine-scanned with several tens of microns precision over the MCP surface using motion stages. Preliminary results are shown in Fig. 7. The standard deviation of the charge footprint per pixel is currently ~ 0.8 mm and the spatial precision will be significantly improved by using charge centroiding between channels. Design changes in the next iteration of Photek tube will further reduce the charge footprint from the MCP.

6. TORCH demonstrator module

A scaled-down demonstrator of a TORCH module has been constructed and is shown in Fig. 8. The optical components are from Schott³ and constitute a quartz radiator plate of dimensions $350 \times 120 \times 10$ mm³ and a focussing block. A test-beam programme is underway where the performance of the Photek Phase 2 MCPs and the customised readout electronics are being verified.

A simulation of the expected performance of the TORCH prototype module in the test-beam is shown in Fig. 9, demonstrating the effect of time of propagation [13]. The x and y positions represent the Monte Carlo truth coordinates on the MCP detector surface, with no pixellation applied. The curved distributions represent the longer path lengths in the quartz as the Cherenkov cone spans larger values of θ_x . The width of the pattern is caused by chromatic dispersion.

7. Summary

TORCH is a novel DIRC-type detector designed to achieve high-precision time-of-flight over large areas, to give a $K - \pi$ separation up to 10 GeV/c. For a ToF resolution of ~ 15 ps per track, a per-photon resolution of 70 ps is required. An ongoing R&D programme is underway including the development of an MCP to

satisfy the challenging TORCH requirements of lifetime, granularity and active area. The first two phases of MCP production show promising results and granularity studies using charge-sharing techniques are ongoing. A test-beam programme is underway to demonstrate the TORCH concept.

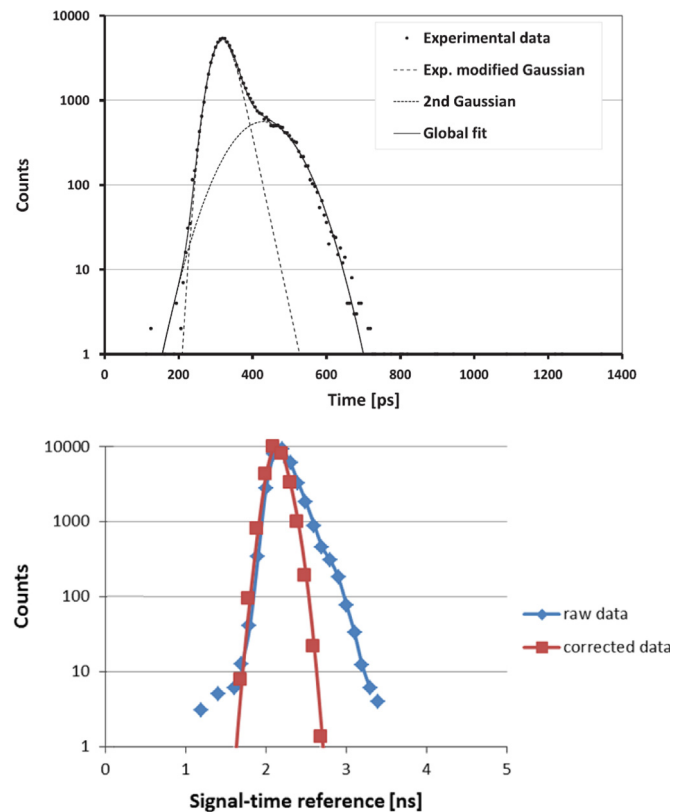

Fig. 6. The timing resolutions achieved with (upper) the Photek Phase 1 MCP-PMT [12], and (lower) the Phase 2 MCP-PMT. Note the logarithmic scales.

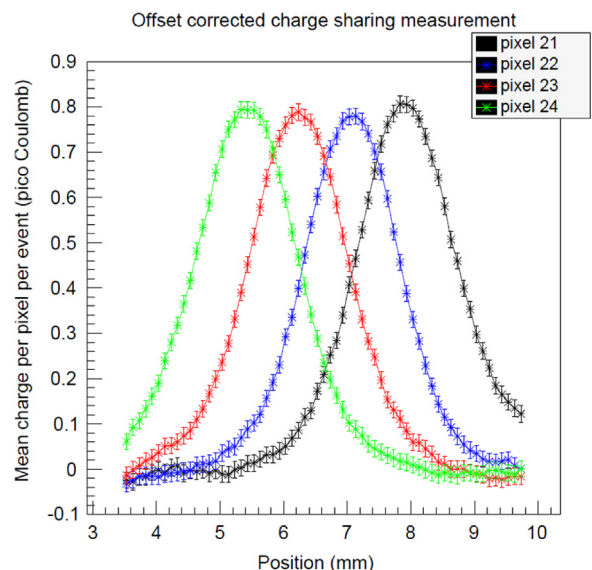

Fig. 7. The effects of charge sharing from the Photek Phase 2 MCP when a pulsed laser is scanned over the pixels of the tube.

³ Schott Suisse SA, 2 Rue Galilée, 1401 Yverdon-les-Bains VD, Switzerland.

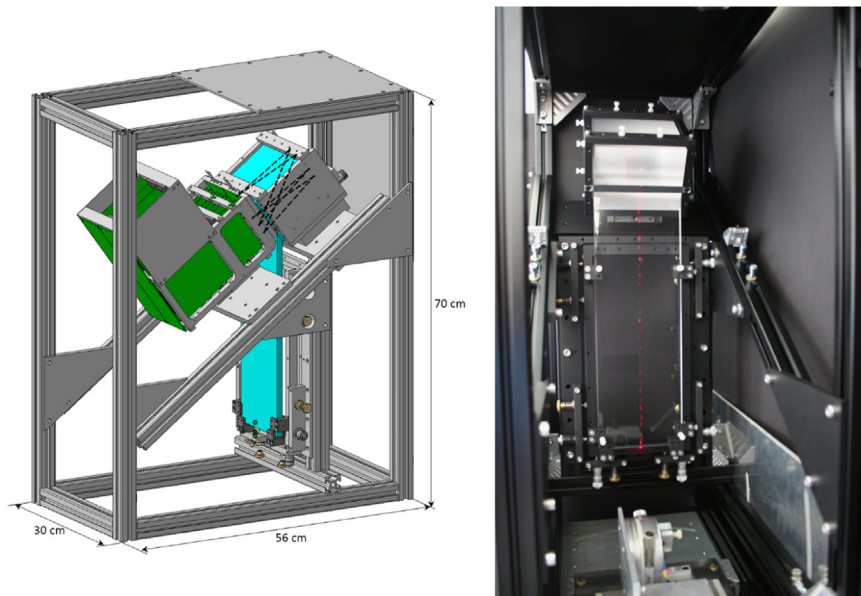

Fig. 8. (Left) a schematic and (right) a photograph of the TORCH demonstrator module.

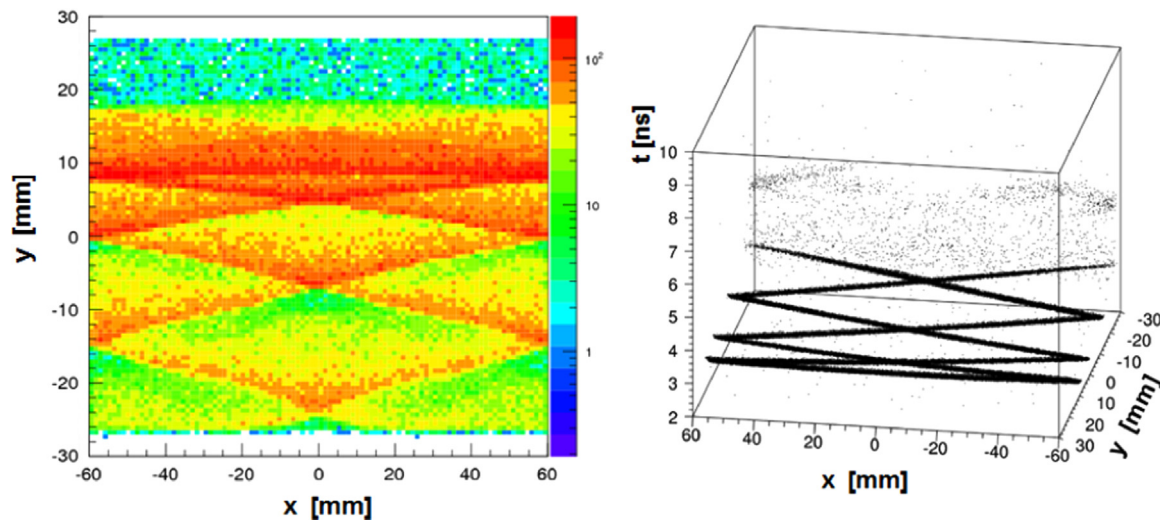

Fig. 9. A simulation of the test-beam hit patterns (left) at the MCP detector surface (the fine pixellation is in the y direction). (Right) The vertical axis shows the time of arrival at the MCP, measuring the time of propagation [13].

Acknowledgments

The corresponding author would like to express his gratitude to the conference organisers who made the 13th Pisa Meeting on Advanced Detectors so enjoyable. The authors gratefully acknowledge support of the European Research Council in the funding of this research (ERC-2011-AdG, 291175-TORCH).

References

- [1] M.W.U. van Dijk, et al., *Nuclear Instruments and Methods A* 766 (2014) 118; N. Harnew, *Physics Procedia* 37 (2012) 626.
- [2] M.J. Charles, R. Forty, *Nuclear Instruments and Methods A* 639 (2011) 173.
- [3] The LHCb Collaboration, Letter of Intent for the LHCb Upgrade, CERN-LHCC-2011-001.
- [4] M. Adinolfi, et al., *European Physics Journal C* 73 (2013) 2431.
- [5] K. Inami, the Belle-II PID Group Collaboration, *Nuclear Instruments and Methods A* 766 (2014) 5.
- [6] C. Schwarz, et al., *Nuclear Instruments and Methods A* 766 (2014) 32.
- [7] A. Britting, et al., *JINST* 6 (2011) C10001.
- [8] A. Lehmann, et al., *Nuclear Instruments and Methods A* 766 (2014) 138.
- [9] T.M. Conneely, J.S. Milnes, J. Howorth, *Nuclear Instruments and Methods A* 732 (2013) 388 (Photek Ltd).
- [10] M. Despeisse, et al., *IEEE* 58 (2011) 202.
- [11] J. Christiansen, HPTDC: high performance time to digital converter, (http://tdc.web.cern.ch/tdc/hptdc/docs/hptdc_manual_ver2.2.pdf).
- [12] L. Castillo García, et al., *Nuclear Instruments and Methods A* 787 (2015) 197.
- [13] K. Föhl, et al., TORCH – An Innovative High-Precision Time-of-Flight PID Detector for the LHCb Upgrade, Conference Paper LHCb-PROC-2015-001.