

Polarization-Insensitive Single Balanced Photodiode Coherent Receiver for Long-Reach WDM-PONs

M. Sezer Erkilinc, *Student Member, IEEE*, Domaniç Lavery, *Member, IEEE*, Kai Shi, *Member, IEEE*, Benn C. Thomsen, *Member, IEEE*, Polina Bayvel, *Fellow, IEEE*, Robert I. Killey, *Member, IEEE* and Seb J. Savory, *Senior Member, IEEE*

Abstract—In an access network based on a passive optical network architecture, coherent detection is attractive since it allows for high receiver sensitivity coupled with inherent frequency selectivity. Nevertheless, solutions employed in core networks are prohibitively complex and costly, requiring the optical complexity of the coherent receivers to be reduced to make them feasible for access networks. For monolithic integration, a key challenge is posed by the polarization beam splitter (PBS). If however the PBS is removed, the receiver needs to be re-designed to be insensitive to the incoming polarization state of the received signal. In this paper, we experimentally demonstrate a polarization-insensitive (*i.e.*, polarization-independent) coherent receiver for the optical network unit (ONU) in passive optical networks (PONs). The receiver consists of only a 3 dB coupler and a single balanced photodiode (BPD) such that the complexity is comparable to a direct detection receiver. The proposed cost-effective coherent receiver is implemented by using the Alamouti polarization-time block coding (PTBC) scheme combined with heterodyne detection. To verify the technique, the Alamouti-coded OFDM signal is rotated over the full Poincaré sphere. Compared to the DP-OFDM signal operating at a net bit rate of 10 Gb/s per polarization (a gross bit rate of 10.7 Gb/s including a 7% FEC overhead), only a 0.6 dB sensitivity degradation is observed. The sensitivity at the FEC threshold, assumed to be 4×10^{-3} , is measured to be -41.5 dBm (56 photons-per-bit) on a 25-GHz grid. Following this, different channel spacings are investigated and, the signal is transmitted over 80 km of standard single mode fiber (SSMF) in a long-reach (LR) wavelength division multiplexed (WDM) PON system. The loss budgets are found to be 43.0 dB and 42.8 dB for 50- and 25-GHz grids, respectively.

Index Terms—Optical access, coherent detection, polarization, Alamouti, polarization-time block code (PTBC), wavelength division multiplexing (WDM), passive optical network (PON).

I. INTRODUCTION

Optical access networks comprise the final fiber connection between an Internet service provider’s terminal equipment, the so-called optical line terminal (OLT), and the customer premises, referred to as the optical network unit (ONU). Next generation optical access networks require a high bit rate-per-user (≥ 1 Gb/s), a high splitting ratio (up to 1000 users), and a long reach (LR) (up to 100 km). In

addition to these requirements, the key constraints are cost-per-bit and compact footprint in such systems [1], [2]. The LR passive optical network (PON) architecture without mid-span amplification is a promising cost-effective solution in which a local exchange can be replaced with a single fiber span of up to 100 km, consolidating backhaul and access spans. The signal generated in the OLT is transmitted through a backhaul fiber span, and subsequently, distributed over a large number of individual fibers using passive splitters with a tree topology, as depicted in Fig. 1. Finally, they are received by ONUs. LR-PONs achieving high split ratios enable the sharing of components between a large number of users, thus, providing significant cost reduction by simplifying the hardware deployed in the field [3], [4].

Digital intradyne coherent receivers, underpinned by digital signal processing (DSP), offer linear field detection with high receiver sensitivities and frequency selectivity. Therefore, they can potentially fulfill the requirements of the next generation optical access networks [5], [6]. However, since the cost requirements are stringent in such networks, the optical complexity of an intradyne receiver (*i.e.*, a polarization beam splitter (PBS) and 90° optical hybrids) makes direct detection receivers favorable for the service vendors (despite their much lower sensitivity) [7]. Moreover, a monolithically integrated receiver used in the ONU is preferable due to its low-cost and compact size. However, the high optical complexity of a polarization diversity intradyne coherent receiver makes its full monolithic integration challenging, mainly due to the PBS. Thus, hybrid implementations (typically using free-space optical components) are commonly employed [8]–[10]. To date, although there are few reported studies regarding the fully monolithically integrated polarization- and phase-diverse intradyne coherent receiver [11]–[13], they are not sufficiently mature and cost-effective for volume production. However, if the PBS is removed from the polarization diversity intradyne receiver, the state of polarization (SoP) of the incoming signal needs to be tracked optically, requiring endless feedback loops, and aligned with the SoP of the local oscillator (LO) laser to maintain the system performance.

Thus, in this paper, we propose a polarization-insensitive (PI), also referred to as polarization-independent, coherent receiver that consists of only a 3 dB coupler and a single balanced photodiode (BPD) (no PBS or 90° optical hybrids) while maintaining a high receiver sensitivity performance (< -40 dBm at a net bit rate of 10 Gb/s at a BER of 4×10^{-3} , the FEC threshold). The proposed receiver is implemented

Manuscript date March 2016. This work was supported by the EPSRC EP/J008842/1, UNLOC EP/J017582/1, and EU FP7 project ASTRON.

The authors are with the Optical Networks Group, Department of Electronic and Electrical Engineering at University College London, London WC1E 7JE, U.K. (e-mail: m.erkilinc@ee.ucl.ac.uk; d.lavery@ucl.ac.uk; k.shi@ucl.ac.uk; b.thomsen@ucl.ac.uk; p.bayvel@ucl.ac.uk; r.killey@ucl.ac.uk; s.savory@ucl.ac.uk).

Color versions of one or more of these figures in this paper are available in the pdf version of this manuscript.

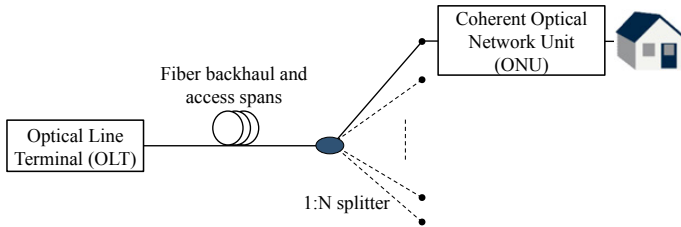

Fig. 1: A typical long-reach PON system architecture.

utilizing a polarization-time block coding (PTBC) scheme combined with heterodyne detection. It is experimentally demonstrated in a wavelength division multiplexing (WDM) system, operating at a net bit rate of 10 Gb/s per user on 50- and 25-GHz grids. The remainder of the paper discusses the previously demonstrated low-cost coherent solutions for (LR-)PONs in Section II, including the description of our proposed PI coherent receiver. The experimental configuration is outlined and the obtained results are discussed in Sections III and IV, respectively. Finally, the conclusions are drawn in Section V.

II. LOW-COST COHERENT SOLUTIONS FOR LR-PONs

To meet the rapidly increasing bandwidth/data demand in long-haul communication links, coherent solutions became the standard technology, offering high capacity with high transmission margins. Moreover, they started to supersede the direct detection solutions in core networks. Typically, conventional (polarization- and phase-diverse intradyne) coherent receivers are employed in core networks where a LO laser's wavelength is set such that it closely matches that of the transmitter laser. Due to its capability of linear optical field detection, superior receiver sensitivity, and frequency selectivity, it is expected that coherent technology will be exploited in optical access systems. However, available coherent technology using an intradyne receiver does not offer a cost-effective implementation and compact footprint due to its high optical complexity. Therefore, the well-established heterodyne detection method has been extensively investigated for use in the ONUs in such networks [1], [5], [15]. Using heterodyne detection, 90° optical hybrids can be replaced by 3 dB couplers, and two balanced photodiodes (BPDs) can be removed as the in-phase (I) and quadrature (Q) components for X- and Y-polarization modes are recovered by applying electrical down-conversion. In a heterodyne receiver, the LO laser and the received signal differ by an intermediate frequency (IF) which is greater than half of the symbol rate ($f_s/2$). Following the detection, an electrical LO is used to down-convert the IF signal to baseband so that in-phase (I) and Q-quadratures are re-constructed [14]. Although this detection scheme increases the bandwidth requirement for the components used in the receiver and causes a 3 dB sensitivity degradation, the optical complexity is significantly reduced.

To further simplify the optical complexity of the heterodyne coherent receiver, a polarization-insensitive (PI) detection scheme can be implemented. A PI coherent receiver, consisting of a PBS, symmetric 3×3 optical coupler (a 120° optical

hybrid) and three photodiodes with analog processing, has been proposed and analytically investigated in [16]. A LO laser enters at 45° to a PBS, splitting it into two orthogonal components with the same amplitude, and the incoming signal is sent directly to one of the photodiodes. It has been experimentally demonstrated for 1.25 and 10 Gb/s LR WDM-PONs using amplitude-shift keying (ASK) signalling, providing loss budgets of 48 dB and 38 dB at a transmission distance over 66 km standard single-mode fiber (SSMF) in [17] and [18], respectively. The main advantage of this low-cost receiver is that the signal can be demodulated using basic analogue processing requiring no DSP or ADC. However, the detection scheme is currently limited to ASK signalling.

Alternatively, a centralized polarization scrambling method enabling PI coherent detection (requiring no polarization controller or PBS at the ONU side) can be employed in the OLT. This technique requires a dual-polarization transmitter, where the symbol time slot is divided into two or more pairs and alternated states of polarization are transmitted in every bit [19]. Using a 3 dB coupler and a single BPD receiver at the ONU, this approach has been demonstrated using a 1.25 Gb/s differential phase shift keying (DPSK) signal, and transmitted over 50 km of SSMF, offering a 46 dB loss budget at a channel spacing of 7.5 GHz [19]. Using the same technique with a 120° optical hybrid and three single-ended photodiodes instead, the achieved bit rate at the same transmission distance was increased to 5 Gb/s using a differential quadrature PSK signal at a 6.25 GHz channel spacing, achieving a 36 dB loss budget [20]. The polarization scrambling method successfully achieves the polarization-independent detection without requiring a PBS at the ONU, but, causes an inherent 3 dB sensitivity penalty due to 50% redundancy.

In this work, we utilize a polarization-time block coding (PTBC) scheme to achieve polarization-independence. The operating principle of the proposed receiver and its first experimental demonstration for PONs is reported in our previous work [21]. The incoming signal is encoded in such a way that there is no need to track the SoP of the incoming signal. Thus, combining the PTBC scheme with heterodyne detection, the optical complexity of the receiver is simplified to a 3 dB coupler and a single BPD. While a single high speed ADC is required to sample the band-pass analog signal, techniques employed in wireless to simplify the DSP and electronics can be employed. Furthermore we note the performance of silicon complementary metal oxide semiconductor (CMOS) technology continues to improve and the cost and power consumption reduce. A similar phenomenon is observed in wireless communication (Rayleigh fading channels) with a two transmit/one receive antenna architecture, and it has been solved by employing space-time block coding schemes. One of the simplest coding schemes to achieve transmit diversity is Alamouti coding [22]. Drawing an analogy between the two polarization modes and two transmit antennae, it has been adapted to optical communication [23], and experimentally demonstrated to mitigate the polarization dependent loss (PDL) in long-haul optical communication systems [24]. To implement this method, two OFDM transmitters, one for each polarization, are required at the OLT side. Therefore, this

transceiver architecture is also referred to as 2×1 multiple-input-single-output (MISO) coherent orthogonal frequency division multiplexing (OFDM) as it employs two transmitters and a single polarization receiver.

A. Description of Alamouti PTBC scheme

In a conventional dual-polarization (DP) system, the OFDM symbols on X- and Y-polarization modes ($E_x = [s_{x1}, s_{x2}, \dots, s_{xM}]$ and $E_y = [s_{y1}, s_{y2}, \dots, s_{yM}]$) are decorrelated. However, the key idea of this coding scheme is to use the channel twice during two symbol durations. Therefore, the Alamouti method introduces a 50% redundancy, as similar to the demonstrations reported in [19], [20]. First, OFDM symbols are grouped into pairs. In the first time slot t , s_{x1} and $s_{y1} = s_{x2}$ are sent whereas in the second time slot $2t$, $-s_{x2}^*$ and $s_{y2} = s_{x1}^*$ are sent on X- and Y-polarization modes, respectively, as illustrated in Fig. 2. Note that $*$ represents the complex conjugate.

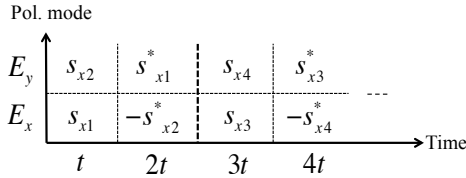

Fig. 2: Illustration of Alamouti coding for a DP-OFDM signal.

On two orthogonal polarization modes ($[E_x \ E_y]^T$ in the form of a Jones vector where T represents the transpose of a vector), the two consecutive OFDM symbol pairs ($[s_{x1} \ s_{x2}]^T$ and $[-s_{x2}^* \ s_{x1}^*]^T$) are mutually orthogonal as can be seen from their inner product, given by

$$[s_{x1} \ s_{x2}][-s_{x2}^* \ s_{x1}^*]^H = -s_{x1}s_{x2} + s_{x2}s_{x1} = 0, \quad (1)$$

where H represents the Hermitian transpose or conjugate transpose. For simplicity, assuming only one symbol pair is sent, the received symbols on X- and Y-polarization modes ($[E_x' \ E_y']^T$) can be written as follows:

$$\begin{bmatrix} E_x' \\ E_y' \end{bmatrix} = \mathbf{H} \begin{bmatrix} E_x \\ E_y \end{bmatrix} = \begin{bmatrix} h_{xx} & h_{xy} \\ h_{yx} & h_{yy} \end{bmatrix} \begin{bmatrix} s_{x1} & -s_{x2}^* \\ s_{x2} & s_{x1}^* \end{bmatrix}, \quad (2)$$

where \mathbf{H} is the transfer function of linear and noiseless channel response describing the polarization effects with the corresponding channel coefficients h_{xx}, h_{xy}, h_{yx} and h_{yy} . Since only one polarization of the received signal, say E_x' , can be co-polarized with the LO laser using the polarization-insensitive (simplified) coherent receiver, the received symbol pairs can be written as follows:

$$s_{x1}' = h_{xx}s_{x1} + h_{xy}s_{x2} \quad (3a)$$

$$s_{x2}' = -h_{xx}s_{x2}^* + h_{xy}s_{x1}^*. \quad (3b)$$

To recover the two transmitted consecutive OFDM symbols on the X-polarization mode (s_{x1} and s_{x2}), both sides of (3b) are

conjugated ((3a) remains unchanged). In this case, the received symbols can be re-written in matrix form as follows:

$$\begin{bmatrix} s_{x1}' \\ s_{x2}' \end{bmatrix} = \begin{bmatrix} h_{xx} & h_{xy} \\ h_{xy}^* & -h_{xx}^* \end{bmatrix} \begin{bmatrix} s_{x1} \\ s_{x2} \end{bmatrix}. \quad (4)$$

Using zero-forcing criteria, the transmitted symbols are recovered by

$$\begin{bmatrix} s_{x1} \\ s_{x2} \end{bmatrix} = \begin{bmatrix} h_{xx} & h_{xy} \\ h_{xy}^* & -h_{xx}^* \end{bmatrix}^{-1} \begin{bmatrix} s_{x1}' \\ s_{x2}' \end{bmatrix}. \quad (5)$$

Due to the orthogonality of $[h_{xx} \ h_{xy}]$ and $[h_{xy}^* \ -h_{xx}^*]$ as shown in (1), $\mathbf{H}^H \mathbf{H} = \alpha \mathbf{I}$ where α is equal to the determinant of a 2-by-2 matrix \mathbf{H} and \mathbf{I} is the identity matrix. Therefore, even though a single polarization is detected, the system performance is independent of any polarization rotation [23] so that there is no need for polarization tracking. Same method can also be used to mitigate polarization dependent loss (PDL), as demonstrated in [24], [25]. However, since the Alamouti coding is a half-rate coding scheme (sending two uncorrelated symbols $[s_{x1} \ s_{x2}]^T$ and their Alamouti-coded pairs $[-s_{x2}^* \ s_{x1}^*]^T$ instead of transmitting four uncorrelated symbols on X- and Y-polarization modes, as illustrated in Fig. 2), it comes at the cost of at least 3 dB sensitivity penalty compared to a dual-polarization (DP) OFDM signal operating at the same bit rate.

III. EXPERIMENTAL CONFIGURATION

The PON test-bed used in the experiment consisted of a DP-OFDM transmitter and aggressors in the OLT unit, followed by a fiber span (80 km SSMF) and a coherent receiver in the ONU. The experimental setup is described in Section III-A. Following the description of the setup, the transmitter DSP for offline DP- and Alamouti-coded OFDM signal waveform generation and the receiver DSP are outlined in Sections III-B and III-C, respectively.

A. LR WDM-PON Test Bed

The downstream LR-PON test-bed employed an OLT transmitting a 10.7 Gb/s (including a 7% HD-FEC overhead, assumed to correct a BER of 4×10^{-3} to below 10^{-15}) WDM (7-channel) Alamouti-coded OFDM signal. To model the LR WDM-PON experimentally, an external cavity laser (ECL) bank centered around 1550 nm with a linewidth of 100 kHz was used as an optical source for the integrated DP IQ-modulator to modulate the central channel (λ_4). Additionally, two single polarization (SP) IQ-modulators with a polarization division multiplexing emulator were employed to generate aggressors, as depicted in Fig. 3.

The signal waveforms were generated offline, as described in Section III-B. The waveforms were uploaded to two 12 GSa/s arbitrary waveform generators (AWGs) with a 3 dB bandwidth of 6 GHz and 8-bit hardware resolution (effective number of bits (ENOB) of 5-bit at 6 GHz) to generate the central channel. The aggressors were first digitally decorrelated by the half of the pattern length, and similarly, they were uploaded

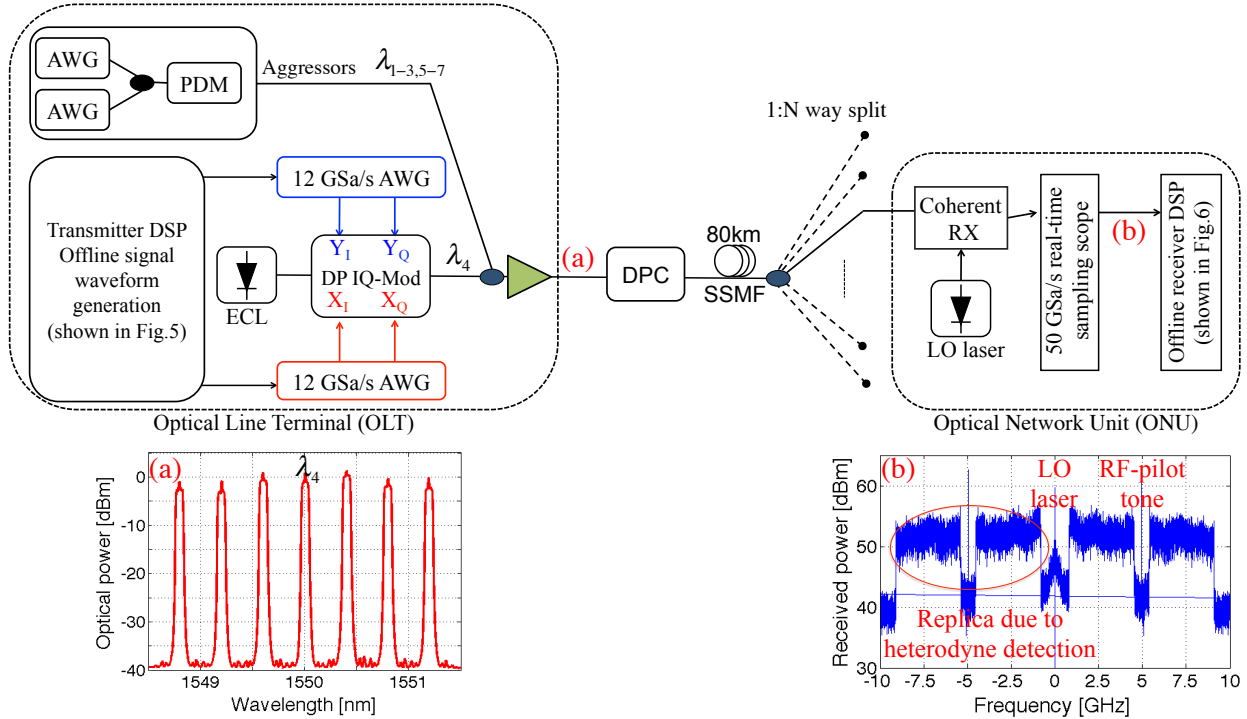

Fig. 3: The long-reach WDM PON test-bed. DPC: Digital polarization controller. Insets: (a) Transmitted optical spectrum and (b) received electrical spectrum after heterodyne detection.

to the memory of the AWGs. The low-pass filters (LPFs) with a bandwidth of 5.5 GHz were used to remove the images generated by the DACs. The modulators were biased close to their minimum transmission (null) points (adding a small DC offset) to insert a DC-pilot tone in the center of the OFDM signal for frequency offset (FO) correction and phase noise compensation (PNC). For the DP-OFDM signal (operating at a bit rate of 21.4 Gb/s), the pilot tone was inserted only on the X-polarization (linearly-polarized signal) with a carrier-to-signal power ratio (CSPR) of approximately -11 dB. For the Alamouti-coded OFDM signal, the pilot tone was inserted on both polarizations (circularly-polarized), leading to a moderate increase in the CSPR value (-9 dB). The aggressors generating the odd channels ($\lambda_{1,3,5,7}$) were decorrelated by 17 ns (3.4 m length of optical fiber), and subsequently, coupled with $\lambda_{2,6}$. Finally, the aggressors and central channel (λ_4) were coupled to generate the 7-channel WDM OFDM signal, occupying a bandwidth of ~ 9 GHz per channel, as shown in the inset (b) of Fig. 3. The channel spacing was varied between 100 and 18 GHz, as further discussed in Section IV.

To evaluate the resilience of the Alamouti-coded OFDM signal to polarization rotation, a digital polarization controller (DPC) was used to rotate the signal over the full Poincaré sphere and the outage probability measurements for the DP-, SP- and Alamouti-coded OFDM signals were compared. An Erbium-doped fiber amplifier (EDFA) followed by a variable optical attenuator (VOA) was used to control the launch power into the fiber. Following this, to model the backhaul and access spans, the Alamouti-coded OFDM signal was transmitted over an 80 km span of SSMF with an attenuation of 0.2 dB/km and a chromatic dispersion coefficient of 16.8 ps/nm/km at

1550 nm. An additional VOA was used to emulate the splitter loss and control the received power.

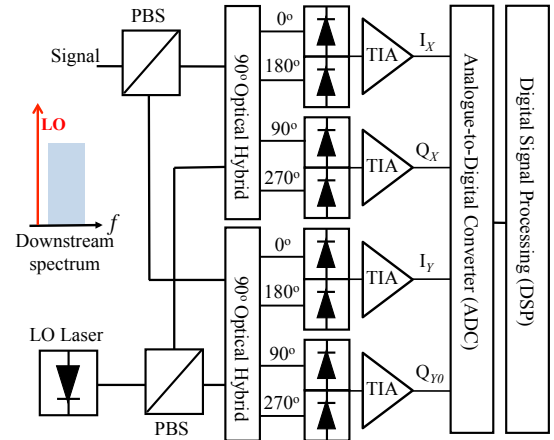

Fig. 4: Polarization- and phase-diverse intradyne (PPDI) coherent receiver.

Initially, for experimental convenience and fair performance comparison between the OFDM signal formats, they were detected using the intradyne receiver configuration (depicted in Fig. 4), and the results are discussed in Section IV-A. The total insertion loss due to the PBS and 90° optical hybrids in the receiver was measured to be 10.5 dB. The two quadratures (BPD output photocurrents denoted as Q_X and Q_Y in Fig. 4) were discarded for the heterodyne reception of the DP-OFDM signal whereas the SP- and Alamouti-coded OFDM signals were detected using a single quadrature (discarding the BPD output photocurrents denoted as Q_X , I_Y and Q_Y in Fig. 4). The LO laser wavelength was set to 1550.05 nm, yielding an

intermediate frequency (IF) of ~ 5 GHz, as shown in the inset of Fig. 4. The frequency selectivity to filter the channel of interest was achieved through the use of a tunable LO laser source with a linewidth of 100 kHz. Following the comparison, the proposed polarization-insensitive coherent receiver was implemented using discrete optical components, as shown in Fig. 5, and the assessment of receiver sensitivity performance for the Alamouti-coded OFDM signal is presented in Section IV-B.

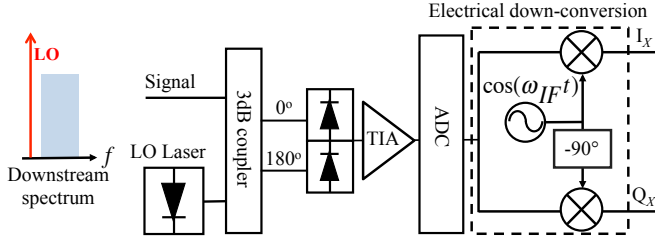

Fig. 5: Polarization-insensitive (independent) (PI) coherent receiver.

B. Transmitter DSP

The OFDM signal frames were generated offline using mutually decorrelated de Bruijn bit sequences of length 2^{17} . The number of data subcarriers was set to 316, each carrying QPSK symbols. To achieve FO correction and PNC via the DC-pilot tone inserted at the transmitter (appears as a RF-pilot tone at the receiver due to heterodyne detection), 18 subcarriers were dropped around the DC-component [26]; so-called virtual (null) subcarriers. Two highly-correlated OFDM symbols were inserted on the X-polarization to achieve OFDM frame synchronization using the Schmidl and Cox algorithm [27]. In the Alamouti-coded OFDM signal case, the synchronization symbols were inserted on both polarizations to avoid power fading on the X-polarization due to polarization rotation. 20 pair-wise training symbols (TSs) at the start of the OFDM frame, and subsequently, 4 pair-wise periodic TSs (one pair-wise TS every 34 OFDM symbols) were inserted for channel estimation [23]. Following the TS insertion, Alamouti coding was applied to the orthogonal polarization states in the time domain, as discussed in Section II-A. Pre-emphasis was applied to minimize the distortion due to the DACs' finite bandwidth, followed by a 512-point inverse fast Fourier transform (IFFT). To compensate for the accumulated chromatic dispersion, 30 samples per OFDM symbol (5% overhead) were appended as a cyclic prefix (CP). Finally, the OFDM waveforms were clipped such that the peak-to-average-power ratios (PAPRs) were set to 7 dB to achieve the optimum receiver sensitivity performance. The total net bit rate was chosen to be 10 Gb/s and 20 Gb/s (a gross bit rate of 10.7 Gb/s and 21.4 Gb/s, assuming a 7% FEC overhead) for the Alamouti-coded and DP-OFDM signal formats, respectively.

C. Receiver DSP

Due to heterodyne reception, the electrical signal after photodetection is real-valued and has a double sideband. This results in a required channel spacing of at least twice the signal

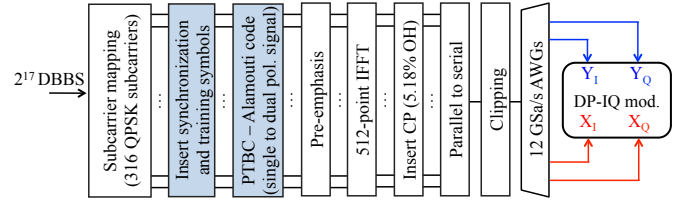

Fig. 6: Transmitter DSP for offline OFDM signal waveform generation. DBBS: de Bruijn bit sequence. The highlighted boxes represent the modified stages compared to the DP-OFDM signal generation when the Alamouti coding scheme is applied.

bandwidth (approximately 18 GHz), which is further discussed in Section IV-B. The pilot tone appears as an IF due to the frequency offset between the transmitter and LO lasers, as shown in the inset (b) of Fig. 3. The received signal was digitized using a single analogue-to-digital converter (ADC) with a sampling rate of 50 GSa/s (23 GHz 3 dB bandwidth and 5-bit ENOB at 10 GHz). Electrical down-conversion at an IF of 5.1 GHz was applied to re-construct the I- and Q-baseband signals. The OFDM frame synchronization was achieved using the Schmidl and Cox algorithm, followed by the FO correction via peak search. Since the RF-pilot tone was distorted by the phase noise in exactly the same way as the signal, it is used to mitigate the phase noise. To separate the pilot tone from the received OFDM signal, a 5th-order Butterworth LPF with a bandwidth of 500 kHz was used. To mitigate the random phase rotations due to laser phase noise, the filtered signal was first conjugated, and subsequently, multiplied with the received signal [26], [28]. Following the serial to parallel conversion, the CP was removed and 512-point FFT was applied prior to signal demodulation. Channel estimation was performed utilizing the TSs used in the zero-forcing equalizer (ZFE). Note that the channel estimation for the Alamouti-coded OFDM signal was achieved using an Alamouti decoder [22]. Finally, the BER was estimated by error counting over 2^{18} bits.

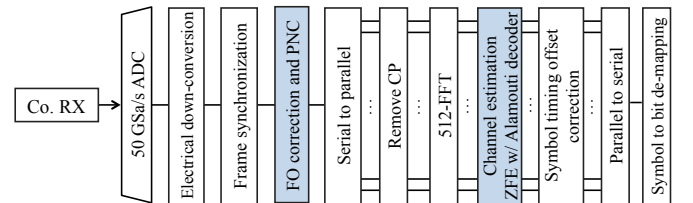

Fig. 7: Receiver DSP for signal demodulation. ZFE: zero-forcing equalizer. The highlighted boxes represent the modified DP-OFDM stages when Alamouti coding scheme is applied.

IV. RESULTS AND DISCUSSION

In this section, first, the performance of SP-, DP- and Alamouti-coded OFDM signals are compared using the intradyne coherent receiver (shown in Fig. 4; discarding the corresponding output photocurrent of BPDs, as explained in Section III-A). The measurements for their resilience to polarization rotation and receiver sensitivities are presented in Section IV-A. Following these measurements, the polarization-insensitive (PI) single BPD coherent receiver (shown in Fig. 5)

was implemented and measurements of its sensitivity using the Alamouti-coded OFDM signal are discussed in Section IV-B.

A. Performance of the intradyne coherent receiver

To assess the SP-, DP- and Alamouti-coded OFDM signals' tolerance to polarization rotation, the signals were rotated using a digital polarization controller, and detected using the intradyne coherent receiver with heterodyne detection. For the DP-OFDM signal, the BPD output photocurrents denoted as Q_X and Q_Y in Fig. 4 were discarded whereas only I_X was detected for the SP- and Alamouti-coded OFDM signals. 625 equally-spaced polarization states over the full Poincaré sphere were taken into account in our measurements. The cumulative distribution function of the OFDM signals with respect to the BERs, *i.e.*, the cumulative probabilities at a given BER for each OFDM signal over 625 equally-spaced polarization states, are shown in Fig. 8 and minimum, maximum and mean BERs are presented in Table I.

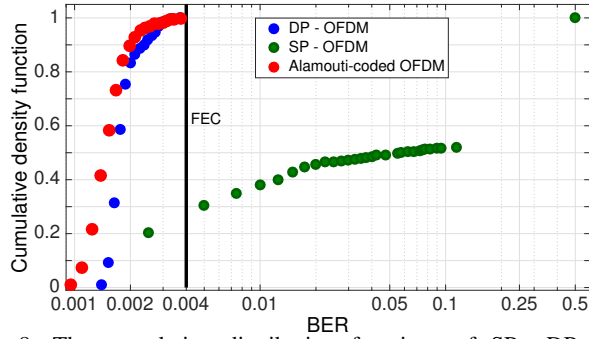

Fig. 8: The cumulative distribution functions of SP-, DP- and Alamouti-coded OFDM signals at different BERs for the 625 equally-spaced polarization states over the Poincaré sphere. Note that the measurements shown here were taken using the intradyne coherent receiver with heterodyne detection.

As a benchmark, the DP-OFDM signal performance was measured. Among the 625 polarization states, the highest measured BER for the DP-OFDM signal at a receiver sensitivity of -35.4 dBm was found to be 3.6×10^{-3} and the mean or expected BER was measured to be 1.8×10^{-3} , below the FEC threshold as expected. The Alamouti-coded OFDM signal achieved a mean BER of 1.6×10^{-3} at a receiver sensitivity of -34.8 dBm and the worst case BER was found to be 4×10^{-3} . All of the measurements successfully achieved a BER below the FEC threshold, as shown in Fig. 8. On the other hand, 50% of the measurements for the SP-OFDM signal failed to achieve a BER below the FEC threshold, as expected.

Table I: BERs in 625 polarization states, rotated over the full Poincaré sphere. The received powers for the SP-, DP-, and Alamouti-coded OFDM signal formats were chosen as -38.7 dBm, -35.4 dBm, and -34.8 dBm, respectively.

Signal \ BER	DP-OFDM	SP-OFDM	Alamouti-coded OFDM
worst case	3.6×10^{-3}	0.5	4×10^{-3}
best case	1×10^{-3}	1.5×10^{-3}	1×10^{-3}
mean	1.8×10^{-3}	0.22	1.6×10^{-3}

Furthermore, the receiver sensitivities of the Alamouti-coded and DP-OFDM signals at a bit rate of 10.7 Gb/s per polarization were shown in Fig. 9. The sensitivities of the DP-OFDM signal using the polarization- and phase-diverse coherent receiver with intradyne and heterodyne detections were found to be -39.8 dBm and -36.5 dBm at the FEC threshold, respectively, observing a penalty of 3.3 dB, as expected. The sensitivity at the FEC threshold for the Alamouti-coded signal was measured to be -35.9 dB, causing an additional 0.6 dB receiver sensitivity penalty. This was due to the insertion of a circularly-polarized DC-pilot tone in the Alamouti-coded OFDM signal whereas a linearly-polarized DC-pilot tone was used for the DP-OFDM signal. Since the polarization- and phase-diverse intradyne coherent receiver was used in these measurements, the maximum LO power at the photodiode input was limited to 3 dBm due to the insertion loss of PBS and 90° optical hybrids. These results imply that the expected receiver sensitivity of the Alamouti-coded OFDM signal can be improved by 7 dB using the proposed PI coherent receiver, as the excess loss due to the PBS and hybrids was measured to be 10.5 dB (assuming a 3.5 dB insertion loss for a nominally 3 dB coupler used in the proposed coherent receiver), as shown in Fig. 9.

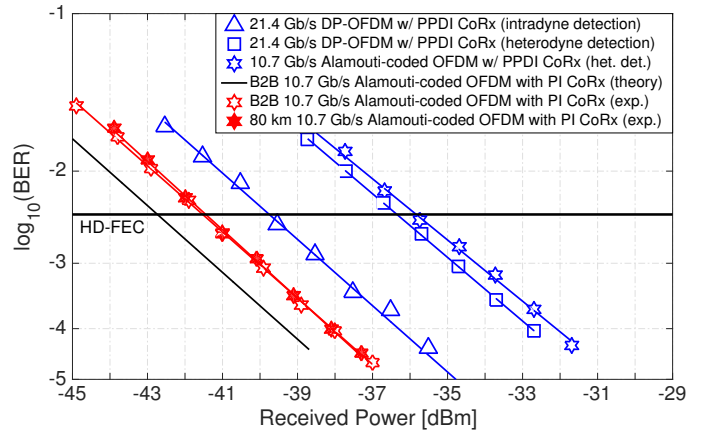

Fig. 9: Receiver sensitivity measurements using the polarization- and phase-diverse intradyne (PPDI) (shown in Fig. 4) and polarization-insensitive (PI) coherent receiver (shown in Fig. 5).

B. Performance of the PI single BPD coherent receiver

The maximum LO power at the photodiode input was set to 10 dBm, due to the reduced insertion loss of the optics in the coherent receiver enabled by the implementation of the proposed PI coherent receiver. Consequently, the receiver sensitivity of the Alamouti-coded OFDM signal was found to be -41.6 dBm, a 5.7 dB sensitivity gain compared to the intradyne coherent receiver with heterodyne detection, whereas hundreds of photons-per-bit is required to achieve the same performance using a direct detection (single-ended photodiode) receiver. Since the PI receiver was implemented using discrete components, an optical delay line (an insertion loss of 1 dB) to align the optical signals in time and additional 0.3 dB optical attenuation to balance the power values on the first and second port of the BPD, were required to optimize

the common mode rejection ratio. Conversely, this loss can be eliminated if the receiver is implemented using monolithic integration. The PI coherent receiver does not require any additional optical components compared to a direct detection receiver. In a direct detection ONU, a local laser is required for the upstream signal. Alternatively, in a coherent ONU, part of the LO laser output can be externally modulated and used as the upstream signal. In the case of heterodyne detection, there is inherent offset between the signal and LO laser, meaning that there will be a guard band (spectral gap) between upstream and downstream signals (when spaced on a 50-GHz grid) without the requirement of wavelength conversion. Previous works have shown that this guard band is sufficient for upstream transmission [29], [30].

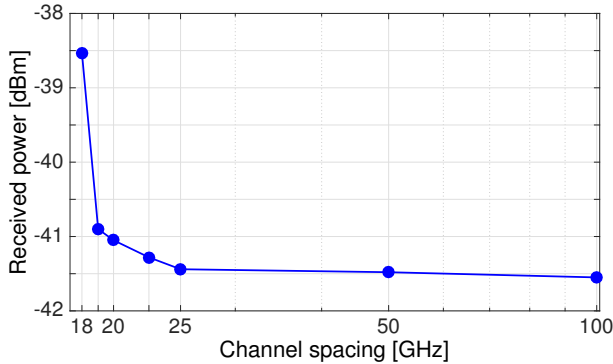

Fig. 10: Sensitivity measurements with respect to channel spacing for the 10.7 Gb/s Alamouti-coded OFDM signal using the PI coherent receiver.

Following the single channel measurements, WDM performance of the Alamouti-coded OFDM signal was assessed. The channel spacing was varied from 100 to 18 GHz and the received power was monitored. Although the minimum channel spacing was found to be 19 GHz where the sensitivity penalty was measured to be within 1 dB, the conventional channel spacing values, 50- and 25-GHz, were chosen for the further measurements. The received powers at the FEC threshold were measured to be -41.6 and -41.4 dBm at 50- and 25-GHz channel spacings, respectively, as shown in Fig. 10. Finally, the Alamouti-coded OFDM signal was transmitted over a SSMF of 80 km with no additional penalty compared to the back-to-back operation at launch powers per channel of 2 and 3 dBm at 50- and 25-GHz grids, respectively, as shown in Fig. 11. On the other hand, chromatic dispersion accumulated along the fiber can be a limiting factor at a bit rate of 10 Gb/s per channel if a direct detection ONU is employed in LR-PONs.

The loss budget determines the maximum transmission distance and number of subscribers that can be served in a LR WDM-PON between the OLT and ONU. In a realistic scenario, the splitter loss and the fiber attenuation are typically assumed to be 3.5 dB and 0.25 dB/km, respectively. Considering only C-band (assumed to be 5 THz) transmission with the achieved budgets in our work shown in Fig. 11, 100 subscribers can be accommodated with a maximum transmission distance of 100 km SSMF ($0.25 \text{ dB/km} \times 100 \text{ km} = 25 \text{ dB loss}$), followed by a 1:128 way split ($3.5 \text{ dB} * \log_2(128) = 24.5 \text{ dB}$

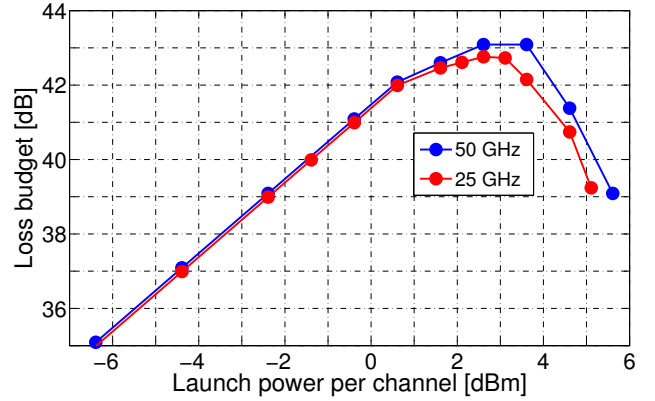

Fig. 11: Loss budgets for the Alamouti-coded OFDM signal on 50- and 25-GHz grids at the FEC threshold (4×10^{-3}) with respect to launch power per channel in 7-channel configuration.

loss). If the channel spacing is reduced to 25 GHz, the number of subscribers can be increased from 100 to 200 (1:256 way split corresponding to a 28 dB loss) with a maximum transmission distance of 80 km SSMF.

V. CONCLUSIONS

We investigated a cost-effective coherent receiver architecture for the ONU in WDM-PONs. The polarization-insensitive (independent) (PI) single balanced photodiode coherent receiver was implemented using the Alamouti polarization-time block coding scheme combined with heterodyne detection. The receiver consists of only a 3 dB coupler and a single balanced photodiode. Crucially, its architecture enables a coherent ONU with no additional optical components compared to a direct detection ONU, and independent of the phase or amplitude modulation scheme employed. The technique was first verified by rotating the signal over the full Poincaré sphere, observing only 0.6 dB receiver sensitivity degradation. A mean BER of 1.6×10^{-3} at a receiver sensitivity of -34.8 dBm was measured for the Alamouti-coded OFDM signal using 625 equally-spaced polarization states.

Following this, the single channel and WDM performance of the Alamouti-coded OFDM QPSK signal operating at a net bit rate of 10 Gb/s per wavelength was assessed using the proposed PI coherent receiver. In both back-to-back operation and transmission, no significant sensitivity difference was observed between the single channel and WDM systems. A receiver sensitivity of -41.4 dBm (56 photons-per-bit) was obtained at 25-GHz channel spacing, enabling 200 users with a maximum transmission distance of 80 km SSMF. This is the first experimental demonstration of the downstream link of a 10 Gb/s per channel WDM-PON at this distance using a polarization-insensitive single balanced photodiode coherent receiver.

ACKNOWLEDGEMENTS

Seb J. Savory thanks the RAEng/Leverhulme Trust for funding his fellowship.

REFERENCES

- [1] H. Rohde, S. Smolorz, J.S. Wey, and E. Gottwald, "Coherent optical access networks," *Proc. OFC*, 2011, paper OTuB1.
- [2] A. Shahpari, R. Ferreira, V. Ribeiro, A. Sousa, S. Z., A. Tavares, Z. Vujicic, F.P. Guimara, J.D. Reis, A.N. Pinto, and A. Teixeira, "Coherent ultra dense wavelength division multiplexing passive optical networks," *Opt. Fiber Technol.*, vol. 26, pp. 100–107, 2015.
- [3] R.P. Davey, D.B. Grossman, M. Rasztoivits-Wiech, D. B. Payne, D. Nesset, A.E. Kelly, A. Rafel, S. Appathurai, and S.H. Yang, "Long-reach passive optical networks," *J. Lightw. Technol.*, vol. 27, no. 1, pp. 273–291, 2009.
- [4] D. P. Shea and J.E. Mitchell, "A 10-Gb/s 1024-way-split 100-km long-reach optical-access network," *J. Lightw. Technol.*, vol. 25, no. 3, pp. 685–293, 2007.
- [5] H. Rohde, E. Gottwald, A. Teixeira, J.D. Reis, A. Shahpari, K. Pulverer, and J.S. Wey, "Coherent ultra dense WDM technology for next generation optical metro and access networks," *J. Lightw. Technol.*, vol. 32, no. 10, pp. 2041–2052, 2014.
- [6] S.J. Savory, "Digital coherent optical access networks," *Proc. IPC*, 2013, invited paper MG2.1.
- [7] N. Cvijetic, M. Cvijetic, M.-F. Huang, E. Ip, Y.-K. Huang, and T. Wang, "Terabit optical access networks based on WDM-OFDMA-PON," *J. Lightw. Technol.*, vol. 30, no. 4, pp. 493–503, 2012.
- [8] L.E. Nelson, X. Zhou, R. Isaac, Y.-M. Lin, J. Chon, and W.I. Way, "Colorless reception of a single 100Gb/s channel from 80 coincident channels via an intradyne coherent receiver," *Proc. IPC*, 2012, paper TuE4.
- [9] A. Beling, N. Ebel, A. Matiss, G. Unterbrsch, M. Nlle, J.K. Fischer, J. Hilt, L. Molle, C. Schubert, F. Verluise and L. Fulop, "Fully-integrated polarization-diversity coherent receiver module for 100G DP-QPSK," *Proc. OFC*, 2011, paper OML5.
- [10] M. Schell, H.G. Bach, K. Janiak, N. Keil, M. Mhrle, P. Runge, and Z. Zhang, "Coherent receiver photonic integrated circuits," *Proc. OFC*, 2013, paper OW3J.6.
- [11] C.R. Doerr, L.L. Buhl, Y. Baeyens, R. Aroca, S. Chandrasekhar, X. Liu, L. Chen, and Y.-K. Chen, "Packaged monolithic silicon 112-Gb/s coherent receiver," *IEEE Photon. Technol. Lett.*, vol. 23, no. 12, pp. 762–764, 2011.
- [12] C.R. Doerr, P.J. Winzer, Y.-K. Chen, S. Chandrasekhar, M.S. Rasras, L. Chen, T.-Y. Liow, K.-W. Ang, and G.-Q. Lo, "Monolithic polarization and phase diversity coherent receiver in silicon," *J. Lightw. Technol.*, vol. 28, no. 4, pp. 520–525, 2010.
- [13] R. Zhang, P. Runge, G. Zhou, R. Gan and R. Klotzer, D. Pech, H.-G. Bach, D. Perez-Galacho, A. Ortega-Murnox, R. Halir, and I. Molina-Fernandez, "56Gbaud DP-QPSK receiver module with a monolithic integrated PBS and 90° hybrid InP chip," in *26th Int'l Conf. on InP and Related Materials*, 2014, paper We-B1-4.
- [14] E. Ip, A.P.T. Lau, D.J.F. Barros, and J.M. Kahn, "Coherent detection in optical fiber systems," *Opt. Express*, vol. 16, no. 2, pp. 753–791, 2008.
- [15] H. Rohde, S. Smolorz, E. Gottwald, and K. Kloppe, "Next generation optical access: 1 Gbit/s for everyone," in *Proc. ECOC*, 2000, paper 10.5.5.
- [16] E. Ciaramella, "Polarization-independent receivers for Low-Cost Coherent OOK Systems," *IEEE Photon. Technol. Lett.*, vol. 26, no. 6, pp. 548–551, 2014.
- [17] M. Presi, F. Bottoni, R. Corsini, G. Cossu, and E. Ciaramella, "All DFB-based coherent UDWDM PON with 6.25 GHz spacing and a >40 dB power budget," *IEEE Photon. Technol. Lett.*, vol. 26, no. 2, pp. 107–110, 2014.
- [18] M. Artiglia, R. Corsini, M. Presi, F. Bottoni, G. Cossu, and E. Ciaramella, "Coherent systems for low-cost 10 Gb/s optical access networks," *J. Lightw. Technol.*, vol. 33, no. 15, pp. 3338–3344, 2015.
- [19] I.N. Cano, A. Lern, V. Polo, and J. Prat, "Polarization independent single-PD coherent ONU receiver with centralized scrambling in udWDM-PONs," in *Proc. ECOC*, 2014, P.7.12.
- [20] I.N. Cano, A. Lern, V. Polo, and J. Prat, "Flexible D(Q)PSK 1.25–5 Gb/s UDWDM-PON with directly modulated DFBs and centralized polarization scrambling," in *Proc. ECOC*, 2015, paper Th.1.3.7.
- [21] M.S. Erkilinc, D. Lavery, R. Maher, M. Paskov, B.C. Thomsen, P. Bayvel, R.I. Killey, and S.J. Savory, "Polarization-insensitive single balanced photodiode coherent receiver for passive optical networks," in *Proc. ECOC*, 2015, paper Th.1.3.3.
- [22] S.M. Alamouti, "A simple transmit diversity technique for wireless communications," *J. on Selected Areas in Commun.*, vol. 16, no. 8, pp. 1451–1458, 1998.
- [23] W. Shieh, "Coherent optical OFDM: has its time come?," *J. Opt. Netw.*, vol. 7, no. 3, pp. 234–255, 2008.
- [24] E. Awwad, Y. Jaouën, and G. Rekaya-Ben Othman, "Polarization-time coding for PDL mitigation in long-haul Pol-Mux OFDM systems," *Opt. Express*, vol. 21, no. 19, pp. 22773–22790, 2013.
- [25] S. Mumtaz, G. Rekaya-Ben Othman, Y. Jaouën, J. Li, S. Koenig, R. Schmogrow, and J. Leuthold, "Alamouti Code against PDL in Polarization Multiplexed Systems," in *Proc. SppCom*, 2011, paper SPTuA2.
- [26] S.L. Jansen, I. Morita, T.C.W. Schenk, N. Takeda, and H. Tanaka, "Coherent optical 25.8-Gb/s OFDM transmission over 4160-km SSMF," *J. Lightwave Technol.*, vol. 26, no. 1, pp. 6–15, 2008.
- [27] T.M. Schmidl and D.C. Cox, "Robust frequency and timing synchronization for OFDM," *IEEE Trans. Commun.*, vol. 45, no. 12, p. 1613–1621, 1997.
- [28] S. Randel, S. Adhikari, and S.L. Jansen, "Analysis of RF-pilot-based phase noise compensation for coherent optical OFDM systems," *IEEE Photon. Technol. Lett.*, vol. 22, no. 17, pp. 1288–1290, 2010.
- [29] D. Lavery, C. Behrens, and S. Savory, "On the impact of backreflections in a bidirectional 10 Gbit/s coherent WDM-PON," in *Proc. OFC*, 2012, paper OTh1F-3.
- [30] J. Reis, A. Shahpari, R. Ferreira, S. Ziaie, D. Neves, M. Lima, and A. Teixeira, "Terabit+ (192× 10 Gb/s) Nyquist shaped UDWDM coherent PON with upstream and downstream over a 12.8 nm band," *J. Lightwave Technol.*, vol. 32, no. 4, pp. 729–735, 2014.