



## Organization Science

Publication details, including instructions for authors and subscription information:  
<http://pubsonline.informs.org>

### Integrating Personality and Social Networks: A Meta-Analysis of Personality, Network Position, and Work Outcomes in Organizations

Ruolian Fang, Blaine Landis, Zhen Zhang, Marc H. Anderson, Jason D. Shaw, Martin Kilduff

To cite this article:

Ruolian Fang, Blaine Landis, Zhen Zhang, Marc H. Anderson, Jason D. Shaw, Martin Kilduff (2015) Integrating Personality and Social Networks: A Meta-Analysis of Personality, Network Position, and Work Outcomes in Organizations. *Organization Science* 26(4):1243-1260. <http://dx.doi.org/10.1287/orsc.2015.0972>

Full terms and conditions of use: <http://pubsonline.informs.org/page/terms-and-conditions>

This article may be used only for the purposes of research, teaching, and/or private study. Commercial use or systematic downloading (by robots or other automatic processes) is prohibited without explicit Publisher approval, unless otherwise noted. For more information, contact [permissions@informs.org](mailto:permissions@informs.org).

The Publisher does not warrant or guarantee the article's accuracy, completeness, merchantability, fitness for a particular purpose, or non-infringement. Descriptions of, or references to, products or publications, or inclusion of an advertisement in this article, neither constitutes nor implies a guarantee, endorsement, or support of claims made of that product, publication, or service.

Copyright © 2015, INFORMS

Please scroll down for article—it is on subsequent pages



INFORMS is the largest professional society in the world for professionals in the fields of operations research, management science, and analytics.

For more information on INFORMS, its publications, membership, or meetings visit <http://www.informs.org>

# Integrating Personality and Social Networks: A Meta-Analysis of Personality, Network Position, and Work Outcomes in Organizations

Ruolian Fang

NUS Business School, National University of Singapore, Singapore 119245, [bizrf@nus.edu.sg](mailto:bizrf@nus.edu.sg)

Blaine Landis

Department of Management Science and Innovation, University College London, London WC1E 6BT, United Kingdom,  
[b.landis@ucl.ac.uk](mailto:b.landis@ucl.ac.uk)

Zhen Zhang

W. P. Carey School of Business, Arizona State University, Tempe, Arizona 85287, [zhen.zhang@asu.edu](mailto:zhen.zhang@asu.edu)

Marc H. Anderson

College of Business, Iowa State University, Ames, Iowa 50011, [mha@iastate.edu](mailto:mha@iastate.edu)

Jason D. Shaw

Faculty of Business, Hong Kong Polytechnic University, Hung Hom, Hong Kong, [jason.shaw@polyu.edu.hk](mailto:jason.shaw@polyu.edu.hk)

Martin Kilduff

Department of Management Science and Innovation, University College London, London WC1E 6BT, United Kingdom,  
[m.kilduff@ucl.ac.uk](mailto:m.kilduff@ucl.ac.uk)

Using data from 138 independent samples, we meta-analytically examined three research questions concerning the roles of personality and network position in organizations. First, how do different personality characteristics—self-monitoring and the Big Five personality traits—relate to indegree centrality and brokerage, the two most studied structurally advantageous positions in organizational networks? Second, how do indegree centrality and brokerage compare in explaining job performance and career success? Third, how do these personality variables and network positions relate to work outcomes? Our results show that self-monitoring predicted indegree centrality (across expressive and instrumental networks) and brokerage (in expressive networks) after controlling for the Big Five traits. Self-monitoring, therefore, was especially relevant for understanding why people differ in their acquisition of advantageous positions in social networks. But the total variance explained by personality ranged between 3% and 5%. Surprisingly, we found that indegree centrality was more strongly related to job performance and career success than brokerage. We also found that personality predicted job performance and career success above and beyond network position and that network position partially mediated the effects of certain personality variables on work outcomes. This paper provides an integrated view of how an individual's personality and network position combine to influence job performance and career success.

**Keywords:** social networks; network position; structural holes; brokerage; indegree centrality; personality; self-monitoring; Big Five personality traits; meta-analysis

**History:** Published online in *Articles in Advance* April 30, 2015.

## Introduction

According to theories of structural advantage, people benefit from occupying advantageous network positions that provide access to useful knowledge, career sponsorship, and psychosocial support (Brass 1984, Burt 1992, Seibert et al. 2001). By contrast, theories of personality suggest that people perform better when they demonstrate specific behavioral tendencies (such as self-monitoring or conscientiousness) valued in work contexts (Barrick et al. 2001, Ng et al. 2005). Recent thinking has brought together research on individuals' structural positions and personality to forge a more comprehensive approach to performance and career success (Kilduff and Tsai 2003). In doing so, three questions

have emerged. First, what effects does personality have on network structure? Second, how do indegree centrality and brokerage, the two network positions most frequently associated with structural advantage, compare in predicting performance and career success? The third is a two-part question concerning the integration of personality and social network position: (i) Once social network position is taken into account, do personality characteristics contribute to the explanation of individuals' performance and career success? And (ii) does network position mediate the relationship between personality and work outcomes?

We address these questions in a meta-analysis of 138 independent samples. Our research examines

how personality characteristics, as reflected in self-monitoring (Snyder 1974) and the Big Five personality traits (extraversion, conscientiousness, openness to experience, agreeableness, and neuroticism; McCrae and John 1992), affect the attainment of advantageous network positions. Both self-monitoring and the Big Five traits have received significant theoretical and empirical attention in the network literature (e.g., Klein et al. 2004, Mehra et al. 2001, Oh and Kilduff 2008, Pollet et al. 2011, Sasovova et al. 2010). Integrating and differentiating these two approaches to personality enriches our understanding of how personality relates to the occupation of key network positions. In particular, we address the apparent confusion between the traits of self-monitoring and extraversion noted in a recent review (Dalal et al. 2015). In the social network domain, our research helps clarify whether network advantage inheres in indegree centrality (the number of incoming ties an individual receives from others) or brokerage (the extent to which an individual is connected to people or clusters of people who are not connected) (Brass 1984, Burt 2005, Seibert et al. 2001). Finally, our research addresses a new challenge to the integration of personality psychology and social networks in examining the recent claim (Burt 2012) that, irrespective of the degree to which personality characteristics influence the attainment of advantageous network positions, the position a person occupies in the social network is the most substantive predictor of performance.

## Integrating Personality and Social Networks

### Research Question 1: How Does Personality Relate to Network Position?

Self-monitoring has been shown to predict social network positions, particularly brokerage positions (Mehra et al. 2001, Oh and Kilduff 2008, Sasovova et al. 2010). The question arises, however, as to whether and how the Big Five traits, which provide a parsimonious approach to salient aspects of personality (Digman 1990), relate to indegree centrality and brokerage. We focus on indegree centrality and brokerage as representative social network positions because they have long been considered crucial to understanding performance outcomes (Freeman et al. 1980). Our predictions apply to both expressive (e.g., friendship) and instrumental (e.g., advice) networks unless otherwise indicated.

*Self-Monitoring.* Self-monitoring theory proposes that people differ in the extent to which they regulate and control how they present themselves in social settings and interpersonal relationships (Snyder 1974). The prototypical high self-monitor strives to generate affective states and behaviors appropriate to specific situations, whereas the prototypical low self-monitor generates expressive behavior from inner affective states and attitudes (Snyder 1979). Chameleon-like high self-monitors

exhibit greater ease and social skills in social interactions than do low self-monitors (Furnham and Capon 1983). They use humor (Turner 1980), pace conversations appropriately (Dabbs et al. 1980), reciprocate self-disclosures when getting to know new people (Shaffer et al. 1982), seek information and advice from well-connected coworkers (Fang and Shaw 2009), talk about other people instead of talking about themselves (Ickes et al. 1986), and resolve conflict through collaboration and compromise (Baron 1989). This interpersonal attentiveness makes high self-monitors desirable targets for others' friendship and advice seeking. Research shows that high self-monitors tend to be the recipients of incoming friendship ties (Sasovova et al. 2010) and that employees tend to approach high self-monitoring managers for help with their emotional problems (Toegel et al. 2007). Thus, we predict that self-monitoring will relate positively to indegree centrality in organizational social networks.

Self-monitoring theory has evolved over a 40-year period to include a more recent emphasis on the ways in which high self-monitors bring others in line with their own agendas in order to achieve their goals (Fuglestad and Snyder 2010). This emphasis on self-monitoring agency is strongly suggestive of the qualities that characterize social network brokers (Burt et al. 1998). Self-monitoring theory suggests that high self-monitors segregate their contacts from each other, whereas low self-monitors bring their contacts together (Snyder 1987, Oh and Kilduff 2008). This difference between high self-monitors and low self-monitors is due, in part, to different preferences regarding choices of activity partners. For each specific activity (e.g., chess, tennis), a high self-monitor will tend to choose a different activity partner, whereas a low self-monitor will tend to choose the same partner regardless of activity (Snyder et al. 1983). High self-monitors emerge as brokers in friendship networks (Mehra et al. 2001, Sasovova et al. 2010) and acquaintanceship networks (Oh and Kilduff 2008). Thus, our prediction is that self-monitoring will relate positively to brokerage in organizational networks, particularly in expressive networks.

*Extraversion.* Extraversion refers to the extent to which people are outgoing, active, gregarious, assertive, energetic, enthusiastic, and cheerful in their outlook (McCrae and John 1992). Extraverted individuals are sensitive to reward signals, seek stimulation, and participate in a wide variety of social activities (Ashton et al. 2002, De Pascalis et al. 2005). Extraverts' socializing tendencies might suggest that they are likely to have larger friendship and advice networks. But there is reason to question this line of reasoning, as evidence has accumulated showing that extraverts fail to attract friends over time (Selfhout et al. 2010) and that the perceived status of extraverts declines over time in group settings (Bendersky and Shah 2013). Thus, research on

extraversion suggests that extraverts' tendencies toward sociability may fail to translate into popularity and may even engender others' dislike (Klein et al. 2004). Theory concerning the relationship between extraversion and brokerage offers little clear guidance. To the extent that extraverts build large networks (Asendorpf and Wilpers 1998, Pollet et al. 2011), brokerage may increase because the number of missing connections among contacts is likely to be high (Bossard 1945). But extraverts prefer to bring their different social contacts together (Kalish and Robins 2006). Therefore, overall, the relationship of extraversion with indegree centrality and brokerage in organizational networks remains unclear (see Stokes 1985).

*Openness to Experience.* Openness to experience captures the extent to which people are imaginative, creative, intellectual, open-minded, and have diverse interests (McCrae and John 1992). Open people may tire of socializing with others who exhibit conventional habits (Cheng et al. 1995, McCrae 1996), thereby potentially reducing their popularity as attractive partners for interactions (i.e., indegree centrality). Consistent with this prediction, research shows that open people not only have smaller team friendship networks but also are disliked in workgroups (Klein et al. 2004). However, research has also shown that people who are more curious are more interesting as conversational partners (Kashdan et al. 2011), which suggests that open people are more likely to be sought after for friendship. We examine these competing ideas concerning openness in relation to indegree centrality. With respect to brokerage, we know that open people exhibit diverse interests (McCrae 1996). In their pursuit of contacts from different, unconnected social circles, open people might therefore serve as network brokers.

*Conscientiousness.* Conscientiousness concerns the extent to which a person is industrious, organized, dutiful, prepared, persistent, and detail oriented (McCrae and John 1992). Because of people's preference for work partners as competent and hardworking (Hinds et al. 2000), conscientious workers may be selected preferentially in these roles. And despite the finding that conscientiousness is unrelated to popularity in team friendship and advice networks (Klein et al. 2004), conscientious people might also be selected into brokerage roles if colleagues from different organizational areas seek them out for resolving work-related problems. We propose, therefore, that conscientiousness relates positively to both indegree centrality and brokerage, particularly in instrumental networks.

*Agreeableness.* Agreeableness concerns the extent to which a person is cooperative, compliant, generous, kind, and trusting (McCrae and John 1992). Agreeable people are motivated to develop positive relations with others (Barrick et al. 2002), show empathy

(Nettle 2006), and cooperate (Denissen and Penke 2008, Holmes 2002). They help integrate conflicting partners' views and needs (Jensen-Campbell et al. 2003). These characteristics make agreeable people attractive friendship partners such that they are more likely to be chosen as friends over time (Selfhout et al. 2010) and in team friendship networks (Klein et al. 2004). Agreeableness, therefore, is likely to relate positively to indegree centrality, particularly in expressive networks.

*Neuroticism.* Neuroticism concerns the extent to which a person is anxious, insecure, hostile, and irritable (McCrae and John 1992). Neuroticism is associated with the frequency with which people feel uneasy and anxious throughout the day (Fleeson and Gallagher 2009, Judge et al. 2014). Neurotic people, who often express negative emotions and may be viewed as high-cost interaction partners, are likely to be avoided. Neuroticism relates negatively to indegree centrality in team friendship and advice networks (Klein et al. 2004)—a finding we expect to hold in organizational social networks.

In summary, we anticipate that self-monitoring predicts both indegree centrality and brokerage, whereas the relation of extraversion to these network outcomes remains unclear. Among the other Big Five traits, we anticipate that conscientiousness and agreeableness relate positively to indegree centrality but that neuroticism relates negatively to indegree centrality. We also anticipate that conscientiousness and openness to experience relate positively to brokerage. We test competing ideas concerning how openness to experience relates to indegree centrality. We do not anticipate how agreeableness and neuroticism relate to brokerage because their patterns of relationships remain unclear, both theoretically and empirically.

## Research Question 2: How Do Indegree Centrality and Brokerage Compare in Explaining Job Performance and Career Success?

Theory and research on social networks emphasize that central network positions provide access to information and other resources and thereby enhance the likelihood that individuals will achieve performance and career success (for reviews, see Burt et al. 2013, Kilduff and Brass 2010). There are several different approaches to understanding network centrality, but two of the most useful approaches with respect to organizational behavior are indegree centrality and brokerage. Indegree centrality indicates an individual's level of activity (Freeman 1979), popularity (Wasserman and Faust 1994), or prominence (Knoke and Burt 1983) and is widely relevant in organizational research (e.g., Burkhardt and Brass 1990, Kilduff and Krackhardt 1994, Klein et al. 2004). Brokerage, measured as betweenness centrality (Freeman 1979) or reverse-scored constraint (Burt 1992), indicates the extent to which the individual connects others (and groups of others) who have

no direct connections to each other. Brokerage is a key construct in modern organizational network theory and research (e.g., Kleinbaum 2012, Sasovova et al. 2010, Stovel and Shaw 2012). Although indegree centrality and brokerage have long been recognized as quite different approaches to network centrality (Freeman et al. 1980), organizational research has overlooked the question of how they compare in explaining performance and career outcomes in organizations.

**Indegree Centrality.** Advantage accrues to people with many connections: they can call on numerous sources of tangible and intangible resources (Brass and Burkhardt 1993). The availability of these various resources is one indicator of power (Brass and Burkhardt 1993, Emerson 1962). In expressive networks, people with many connections are likely to receive social support and other psychosocial resources necessary for work performance and career success (e.g., Baldwin et al. 1997, Gibbons 2004). In instrumental networks, people with many connections are likely to receive and accumulate task-related knowledge, expertise, and information. These resources are important for enhancing performance and prospects of promotion (e.g., Baldwin et al. 1997). People with higher indegree centrality are likely to achieve higher performance and greater career success (e.g., Baldwin et al. 1997, Sparrowe et al. 2001).

**Brokerage.** Brokerage positions confer different advantages than do positions high in indegree centrality. A brokerage position provides people with access to individuals (or clusters of individuals) who are disconnected from one another (Burt 1992). Thus, brokerage positions are theorized to offer three advantages: breadth of nonredundant information from diverse contacts, timeliness of information passing between disconnected groups, and arbitrage in bringing separate groups together (Burt et al. 2013). Network brokers in organizations move unknown or misunderstood information to places where it has value. These brokers are rewarded with high performance evaluations, generous compensation packages, and early promotions (Burt et al. 2013).

Overall, indegree centrality and brokerage both provide people with structural advantage. But how do these two structural positions compare in facilitating job performance and career success? Existing research is unclear on this important question. Therefore, our second contribution to the microfoundations of organizational networks is an empirical one: the current meta-analysis examines the relative importance and predictive power of indegree centrality and brokerage in explaining individuals' job performance and career success.

### Research Question 3: How Do Personality and Network Position Relate to Job Performance and Career Success?

We have articulated that people with certain personality characteristics are more likely to occupy structurally

advantageous positions and that people who occupy advantageous positions are likely to have better performance and career outcomes. But do personality and network position have independent effects on work outcomes? That is, do personality variables relate to work outcomes when social network position is taken into account (and vice versa)? Further, does network position mediate the relationship between personality and work outcomes? These questions reflect an ongoing debate at the intersection of personality psychology and social network research (Balkundi et al. 2011, Kilduff and Tsai 2003).

Existing research suggests that self-monitoring and the Big Five traits influence people's attainment of indegree centrality and brokerage positions (e.g., Klein et al. 2004, Mehra et al. 2001, Oh and Kilduff 2008, Sasovova et al. 2010). Evidence also shows that these network positions contribute to performance outcomes (e.g., Baldwin et al. 1997, Burt 1992, Cross and Cummings 2004, Mehra et al. 2001, Seibert et al. 2001). Furthermore, personality meta-analyses show that self-monitoring and the Big Five traits predict job performance and career success (e.g., Barrick et al. 2001, Day et al. 2002, Ng et al. 2005). Together, findings from these different research streams suggest that people with certain personality traits tend to attain structurally advantageous positions and that the occupation of these advantageous positions, in turn, influences people's performance and career success. The attainment of an advantageous network position is one possible mechanism by which personality affects work outcomes.

Prior work on the relationships among personality, network position, and performance supports this possibility. Mehra et al. (2001) found that self-monitoring predicted employees' occupancy of brokerage positions and that the self-monitoring and network variables predicted workplace performance when examined separately and simultaneously. These results indicate a pattern of *partial* mediation in which self-monitoring affects the attainment of advantageous network position, and both self-monitoring and network position influence performance. A recent study on individuals' multirole networks (Burt 2012) found that individuals' personality characteristics measured as consistent network behaviors across roles (called "network-related personality") predicted the occupancy of strategically advantageous positions. Although this research asserted that "much of the variance in network advantage reflects personality, but that portion of advantage variance has little to do with success" (Burt 2012, p. 586), we suggest that this conclusion is premature, given Burt's (2012) indirect measurement of network-related personality and the prior theory and evidence that we have summarized above.

Overall, findings from both personality psychology and social network research highlight the need to investigate (a) whether personality (self-monitoring and the

Big Five) and advantageous network positions (indegree centrality and brokerage) predict job performance and career success when taking each other's effects into account and (b) whether the effects of personality on performance outcomes are mediated by the attainment of structurally advantageous network positions. Our meta-analysis, which takes into account primary studies across the personality and network literatures, examines both direct effects and potential mediation relationships.

## Method

### Literature Search

The search for relevant studies began with a keyword search of PsycINFO, ABI/Inform, and Web of Science using the terms for personality (e.g., “personality,” “traits,” “individual differences,” “self-monitoring,” “five-factor model traits,” “Big Five,” “extraversion,” “agreeableness,” “conscientiousness,” “neuroticism,” “openness to experience”), network position (e.g., “centrality,” “degree,” “indegree,” “brokerage,” “betweenness,” “constraint”), the term “social networks” in general, and terms for network centrality and work outcomes (e.g., “job performance,” “task performance,” “in-role performance,” “achievement,” “career success,” “promotion,” “compensation,” “bonus,” “salary”). We also conducted a manual search of journals such as *Social Networks*, *Administrative Science Quarterly*, *Organization Science*, the *Academy of Management Journal*, the *Journal of Management*, the *Journal of Personality and Social Psychology*, and the *Journal of Applied Psychology*, which are likely to publish relevant empirical research. To collect unpublished studies, we searched Dissertation Abstracts International as well as the conference programs of the Academy of Management and other network conferences (as of August 2014). We also made announcements on several electronic mailing lists, soliciting working papers and unpublished data. In addition, we contacted researchers directly to collect available but unpublished data.

### Inclusion Rules

To be included in the meta-analysis, a study had to (a) report an effect size statistic on the relationship of a personality variable and a measure of network centrality, or an effect size statistic on the relationship of a measure of network centrality and an outcome, and (b) examine one of these relationships in an adult sample. In addition, studies had to compute a sociometric measure of centrality (i.e., indegree or betweenness) from a full network of relations among individuals within organizations or an egocentric measure of centrality (i.e., structural holes or reverse-scored constraint) from an ego or full network within organizations. We also scrutinized published studies for data that could capture these relationships but were not reported. We obtained these relationships directly from the authors (e.g., Shaw et al.

2005, Zhang and Peterson 2011). The primary studies included in this meta-analysis are provided in the appendix, and the full details of our coding decisions are available from the first two authors upon request.

### Coded Variables

*Personality.* Previous meta-analytic research has relied on the Big Five (Bono and Judge 2004, Chiaburu et al. 2011, Judge et al. 2002) as an organizing framework for sorting a number of more specific facets under the five broad factors. The majority of the studies examined the Big Five traits, but in cases where primary studies featured a narrower trait, the first three authors independently coded the trait using the Big Five definitions commonly provided in prior research (e.g., Hough and Ones 2001, Zhao and Seibert 2006, Zimmerman 2008). Disagreements were resolved by discussion. For example, we categorized trait negative affect as neuroticism, achievement as conscientiousness, and tolerance and empathy as agreeableness. These narrower traits have been theoretically argued to be subdimensions of their respective Big Five traits (e.g., Hough and Ones 2001). Both measures of self-monitoring were included (Lennox and Wolfe 1984, Snyder 1974).

*Network Position.* We included two different types of social network positions: indegree centrality and brokerage. Indegree centrality was measured as the number of incoming ties received from others (Freeman 1979). Brokerage was measured as betweenness centrality (Freeman 1979) or structural holes (i.e., reverse-scored constraint; see Burt 1992). The first two authors conducted independent reviews of the studies and then compared coding sheets. We resolved disagreements by discussion. We examined network position separately in two types of social networks: expressive (e.g., friendship and social support) versus instrumental (e.g., workflow, information and advice). We also conducted analyses for brokerage by analyzing only betweenness centrality. The results and conclusions remained unchanged.

*Job Performance and Career Success.* We focused on two work outcomes: job performance (i.e., success in completing the tasks and responsibilities required by individuals in a particular role) and career success (i.e., achievement of objectively observable outcomes such as promotion and compensation). Job performance measures included supervisor or peer ratings, performance evaluations based on company records, and objective measures of job performance. Variables such as actual promotion, likelihood of promotion, salary, and bonuses were coded as career success.

*Potential Methodological Moderators.* When there was evidence showing that a meta-analytic relationship exhibited heterogeneity, we examined several potential methodological moderators concerning study

characteristics: (1) full versus ego network measures (pertaining to brokerage only), (2) adult student versus adult employee samples, (3) concurrent versus predictive research designs, and (4) published versus unpublished studies. The last moderator was examined to check for publication bias. Specifically, we compared estimated effect sizes for published versus unpublished data (the latter group including data from unpublished dissertations, conference papers, and working papers). One published social network study examined relationships at the organizational level (Shaw et al. 2005). From the authors, we were able to obtain individual-level correlations within each social network and treated these effect sizes as independent (following the guidance from Hunter et al. 1982, pp. 429–443) and coming from a published study. Given that the majority of the relationships did not show heterogeneity, we provide the moderator analysis findings in Online Appendix 2 (available as supplemental material at <http://dx.doi.org/10.1287/orsc.2015.0972>) instead of the Results section.

### Meta-Analytic Procedures

We followed the random-effects meta-analytic procedures described by Hunter and Schmidt (2004). We corrected the observed effect sizes for unreliability but not for range restriction. Specifically, personality variables and job performance were corrected for unreliability based on reported local reliability estimates (i.e., internal consistency coefficients). For a small proportion of studies that did not report a reliability estimate for the personality variables or for job performance, we used the average of available reliabilities for these variables (average reliabilities for openness to experience = 0.79, conscientiousness = 0.80, extraversion = 0.86, agreeableness = 0.77, neuroticism = 0.82, self-monitoring = 0.80, and job performance = 0.92). Network centrality variables and career success were not corrected for unreliability because of the lack of information provided in primary studies. When the primary studies provided multiple correlations of a relationship based on a single sample, we averaged them into one correlation. This ensured the effect sizes in our meta-analysis were independent.

We report 95% confidence intervals (CIs) around the estimated true-score correlations. In addition, we report 80% credibility intervals (CVs), which provide information on the possible range of corrected correlations. If the 80% CV of a particular effect size is wide and includes zero, this suggests the existence of potential moderator(s) on the focal effect size. As Whitener (1990, p. 317) suggested, CVs alone “cannot identify which moderators are working,” and therefore testing a particular categorical moderator “requires the use of a confidence interval for populations or subpopulations.”

Within the same social network, one person’s network position is not independent of a peer’s network position. There are potential concerns about whether correlations based on nonindependent data in primary studies

could invalidate the meta-analytic procedures. Therefore, before performing the meta-analysis, we conducted a Monte Carlo simulation study to examine whether correlations derived from such data follow the prescribed distribution of the Hunter and Schmidt (2004) meta-analytic procedures. We varied the magnitude of the correlation coefficient, network size, the extent of nestedness within the network, and total number of individuals in the network ( $N$ ). For each condition, we generated 5,000 replications. The empirically derived standard deviation of the sampling error for the correlation ( $SD_r$ ) was compared with that based on the Hunter and Schmidt formula ( $SD_r = (1 - r^2)/\sqrt{N - 1}$ ). We found that the bias for  $SD_r$  was minimal (ranging from -1.5% to 1.3%). Thus, we continued with Hunter and Schmidt’s procedures.

*Potential Outliers.* We used the sample-adjusted meta-analytic deviancy statistic to identify potential outliers (Huffcutt and Arthur 1995), with corrections proposed by Beal et al. (2002). For the relationships between personality and network position, only one or two outlier coefficients were identified for about 10% of these relationships, and no outliers were found for the rest of the relationships. Including or excluding these potential outliers did not change our conclusions regarding the particular relationships. For the indegree centrality–career success relationship in instrumental networks, however, we identified one outlier study (Gargiulo et al. 2009) that had an extremely large sample ( $N = 2,000$  investment bankers). Including or excluding this study changed the true correlation estimate and the path coefficient between centrality and work outcomes in instrumental networks. Thus, we conducted separate analyses including and excluding this study and report two sets of results for instrumental networks.

*Meta-Analytic Regression, Relative Weight Analysis, and Path Modeling.* Following prior research (e.g., Chiaburu et al. 2011, O’Boyle et al. 2012, Zimmerman 2008), we used the meta-analyzed true-score correlations matrices to conduct regression and relative weight analyses (Johnson 2000) as well as meta-analytic path modeling (Viswesvaran and Ones 1995). Specifically, to address Research Questions 1 and 2, we conducted regression and relative weight analyses to examine the relative importance of self-monitoring and the Big Five traits in predicting indegree centrality and brokerage and the relative importance of indegree centrality versus brokerage in predicting work outcomes. To address Research Question 3, we conducted path modeling analyses that simultaneously captured (a) the influence of personality (self-monitoring and the Big Five) on the two network positions, (b) the influence of personality and the network positions on work outcomes, and (c) the potentially mediated effect of personality on work outcomes through network position. We ran separate analyses for expressive and instrumental networks. In the

correlation matrices, we supplemented our newly calculated true-score correlations with effect sizes from prior meta-analyses. More details are provided in Online Appendix 3. As recommended by Viswesvaran and Ones (1995), we used the harmonic mean of the sample sizes in the relevant cells of the correlation matrix to represent the sample size for each path model. Following prior meta-analytic research on the Big Five and work outcomes (e.g., Chiaburu et al. 2011), we reported total explained variance ( $R^2$ ) and the change in multiple  $R$  values associated with a predictor or a predictor group. The changes in multiple  $R$  values show the incremental predicting power of the focal variable (or a variable group) above and beyond other predictors in the model.

## Results

### Research Question 1: How Does Personality Relate to Network Position?

To address this question, we conducted meta-analyses on the bivariate correlations between personality (self-monitoring and the Big Five) and network positions (indegree centrality and brokerage). We report these bivariate correlations in Online Appendix 1. These correlations were prerequisites for the matrices used in the multivariate analyses (with details shown in Online Appendix 3). The meta-analytic regressions and relative weight analyses are shown in Table 1.

We predicted that self-monitoring would relate positively to indegree centrality (in both types of organizational networks) and to brokerage (particularly in expressive networks). The results, shown in Table 1, support our predictions. Self-monitoring related positively to indegree centrality across expressive ( $\beta = 0.17, p < 0.001$ ) and instrumental ( $\beta = 0.15, p < 0.001$ ) networks. Self-monitoring also related positively to brokerage in expressive networks ( $\beta = 0.16, p < 0.001$ ) but not to brokerage in instrumental networks ( $\beta = 0.04, n.s.$ ). The changes in multiple  $R$  values ( $\Delta R_{SM\_over\_Big\_Five}$ ), which indicate the predictive power of self-monitoring over the Big Five in explaining the network positions, show patterns of results consistent with the regression coefficients. After controlling for the Big Five, self-monitoring significantly predicted indegree centrality in expressive and instrumental networks and brokerage in expressive networks. The relative weight analysis results, reported in the “%RW” column in Table 1, also are consistent with our predictions. Together, our results show that high self-monitors were sought out for friendship and advice and held brokerage positions in expressive networks.

Prior research offered no clear prediction concerning the relations of extraversion and openness to experience to indegree centrality. The results (see Table 1) show that extraversion was not related to indegree centrality in either expressive ( $\beta = 0.05, n.s.$ ) or instrumental

**Table 1 Meta-Analytic Regression Models for Personality and Network Position with Relative Weight Analysis**

	Indegree			Brokerage		
	$\beta$	RW	%RW	$\beta$	RW	%RW
<b>Expressive networks</b>						
<i>Self-monitoring</i>	0.17***	0.028	61.1	0.16***	0.024	62.0
<i>Extraversion</i>	0.05	0.006	12.8	-0.01	0.004	10.6
<i>Openness to experience</i>	-0.10***	0.005	11.7	0.09**	0.008	20.8
<i>Conscientiousness</i>	0.02	0.001	2.4	0.06*	0.002	5.5
<i>Agreeableness</i>	0.04	0.003	5.6	-0.01	0.000	0.5
<i>Neuroticism</i>	-0.05*	0.003	6.3	0.02	0.000	0.6
Total $R$ ( $R^2$ )	0.216 ( $R^2 = 0.047^{***}$ )			0.198 ( $R^2 = 0.039^{***}$ )		
$\Delta R_{SM\_over\_Big\_Five}$	0.063***			0.063***		
$\Delta R_{Big\_Five\_over\_SM}$	0.036***			0.028**		
Harmonic mean sample size	2,199			1,579		
<b>Instrumental networks</b>						
<i>Self-monitoring</i>	0.15***	0.023	48.0	0.04	0.004	14.5
<i>Extraversion</i>	0.04	0.008	16.3	0.09**	0.009	32.8
<i>Openness to experience</i>	0.03	0.002	5.1	0.03	0.003	9.2
<i>Conscientiousness</i>	0.07**	0.006	12.3	0.13***	0.010	36.7
<i>Agreeableness</i>	-0.03	0.001	1.3	-0.05*	0.001	3.5
<i>Neuroticism</i>	-0.08**	0.008	17.1	0.04	0.001	3.2
Total $R$ ( $R^2$ )	0.219 ( $R^2 = 0.048^{***}$ )			0.164 ( $R^2 = 0.027^{***}$ )		
$\Delta R_{SM\_over\_Big\_Five}$	0.046***			0.004		
$\Delta R_{Big\_Five\_over\_SM}$	0.049***			0.084***		
Harmonic mean sample size	2,242			2,067		

Notes.  $\beta$ , standardized regression coefficients; RW, raw relative weights (see Johnson 2000); %RW, relative weights expressed as a percentage of total explained variance of the dependent variable ( $R^2$ );  $R$ , multiple correlation;  $\Delta R$ , incremental change in multiple  $R$  values—for example,  $\Delta R_{SM\_over\_Big\_Five}$  refers to the incremental change in multiple  $R$  values for self-monitoring over the Big Five traits.

\* $p < 0.05$ ; \*\* $p < 0.01$ ; \*\*\* $p < 0.001$ .



**Table 2** Meta-Analytic Regression Models for Network Position and Work Outcomes with Relative Weight Analysis

	Job performance			Career success		
	$\beta$	RW	%RW	$\beta$	RW	%RW
Expressive networks						
<i>Indegree</i>	0.14***	0.019	81.3	0.11***	0.012	82.5
<i>Brokerage</i>	0.03	0.004	18.7	0.02	0.003	17.5
Total $R$ ( $R^2$ )	0.152 ( $R^2 = 0.023^{***}$ )			0.121 ( $R^2 = 0.015^{***}$ )		
$\Delta R_{Indegree\_over\_Brokerage}$	0.062***			0.051***		
$\Delta R_{Brokerage\_over\_Indegree}$	0.002			0.001		
Harmonic mean sample size	3,857			2,842		
Instrumental networks						
<i>Indegree</i>	0.19***	0.034	84.8	0.19***	0.037	72.2
<i>Brokerage</i>	0.02	0.006	15.2	0.07***	0.014	27.8
Total $R$ ( $R^2$ )	0.200 ( $R^2 = 0.040^{***}$ )			0.226 ( $R^2 = 0.051^{***}$ )		
$\Delta R_{Indegree\_over\_Brokerage}$	0.090***			0.066***		
$\Delta R_{Brokerage\_over\_Indegree}$	0.000			0.006***		
Harmonic mean sample size	6,615			4,542		

Notes.  $\beta$ , standardized regression coefficients; RW, raw relative weights (Johnson 2000); %RW, relative weights expressed as a percentage of total explained variance of the dependent variable ( $R^2$ );  $R$ , multiple correlation;  $\Delta R$ , incremental change in multiple  $R$  values. When we predict career success with instrumental network indegree and brokerage centralities, if we add the outlier study (Gargiulo et al. 2009) in the analysis, then harmonic mean sample size is 5,410, coefficient of indegree = 0.36,  $p < 0.001$ ;  $\Delta R_{Indegree\_over\_Brokerage} = 0.190$ ,  $p < 0.001$ ; coefficient of brokerage =  $-0.01$ ,  $p < 0.30$ ; and  $\Delta R_{Brokerage\_over\_Indegree} = 0.000$ ,  $p > 0.30$ .

\*\*\* $p < 0.001$ .

( $\beta = 0.04$ , n.s.) networks. We found a negative relationship between openness to experience and indegree centrality in expressive networks only ( $\beta = -0.10$ ,  $p < 0.001$ ). The anticipated positive relationship between conscientiousness and indegree centrality was found for instrumental networks only ( $\beta = 0.07$ ,  $p < 0.01$ ). As expected, neuroticism related negatively to indegree centrality across both expressive ( $\beta = -0.05$ ,  $p < 0.05$ ) and instrumental ( $\beta = -0.08$ ,  $p < 0.01$ ) networks. There are competing processes that may lead extraverts either to be brokers or to inhabit closed networks. In testing these competing theoretical predictions, we found that extraversion related positively to brokerage in instrumental networks only ( $\beta = 0.09$ ,  $p < 0.01$ ). As predicted, openness to experience related positively to brokerage in expressive networks ( $\beta = 0.09$ ,  $p < 0.01$ ), and conscientiousness related positively to brokerage in expressive ( $\beta = 0.06$ ,  $p < 0.05$ ) and instrumental ( $\beta = 0.13$ ,  $p < 0.001$ ) networks.

### Research Question 2: How Do Indegree Centrality and Brokerage Compare in Explaining Job Performance and Career Success?

The meta-analytic correlations of indegree centrality and brokerage with job performance and career success are shown in Online Appendix 1. These correlations form the bases of the matrices for the multivariate analyses (with details shown in Online Appendix 3). The meta-analytic regression and relative weight analyses are shown in Table 2.

The results in Table 2 show that, controlling for brokerage, indegree centrality was a significant predictor

of job performance across expressive ( $\beta = 0.14$ ,  $p < 0.001$ ) and instrumental ( $\beta = 0.19$ ,  $p < 0.001$ ) networks. And, controlling for brokerage, indegree centrality remained a significant predictor of career success in both expressive ( $\beta = 0.11$ ,  $p < 0.001$ ) and instrumental ( $\beta = 0.19$ ,  $p < 0.001$ ) networks. Consistent with these regression coefficients, the changes in multiple  $R$  values ( $\Delta R_{Indegree\_over\_Brokerage}$ ) show that indegree centrality was predictive of job performance and career success above and beyond brokerage.

By contrast, controlling for indegree centrality, brokerage failed to predict job performance in either expressive ( $\beta = 0.03$ , n.s.) or instrumental ( $\beta = 0.02$ , n.s.) networks. But controlling for indegree centrality, brokerage predicted career success in instrumental ( $\beta = 0.07$ ,  $p < 0.001$ ) but not in expressive ( $\beta = 0.02$ , n.s.) networks. Consistent with these regression coefficients, the changes in multiple  $R$  values ( $\Delta R_{Brokerage\_over\_Indegree}$ ) show that brokerage only predicted career success in instrumental networks above and beyond indegree centrality. Overall, the relative weight analysis results also supported these patterns of findings. Thus, we found that indegree centrality was a more potent predictor of job performance and career success than brokerage in both types of social networks.

### Research Question 3: How Do Personality and Network Position Relate to Job Performance and Career Success?

Our third research question has two component parts: (1) To what extent do personality variables (self-monitoring

and the Big Five) and network variables (indegree centrality and brokerage) predict job performance and career success in the presence of each other? (2) Do network variables mediate the effects of personality variables on work outcomes? To address these issues, we conducted meta-analytic path modeling analyses for expressive and instrumental networks and report the findings in Figures 1 and 2, respectively. In both figures, the left-hand panel of the model resembles the results in Table 1, and the right-hand panel of the model resembles the results in Table 2. Going beyond the results reported in Tables 1 and 2, which involve one dependent variable at a time, Figures 1 and 2 show path modeling results that examine multiple dependent variables simultaneously. Thus, we are able to examine various effects of personality variables on work outcomes (i.e., direct effects and potentially mediated effects via indegree centrality and brokerage). Table 3 shows these direct and mediated effects as well as their 95% CIs.

The path coefficients presented in Figures 1 and 2 show how personality related to indegree centrality and brokerage and how both personality and network position related to job performance and career success. The models for expressive networks ( $\chi^2 = 10.87$ ,  $df = 10$ ,  $p > 0.36$ , comparative fit index (CFI) = 1.00, Tucker-Lewis index (TLI) = 1.00, root mean square error of approximation (RMSEA) = 0.006) and instrumental networks ( $\chi^2 = 14.93$ ,  $df = 11$ ,  $p > 0.18$ , CFI = 1.00, TLI = 0.99, RMSEA = 0.011) both achieved satisfactory fit.

As shown in Figure 1, concerning the link between personality and advantageous positions in expressive networks, self-monitoring ( $\beta = 0.17$ ,  $p < 0.001$ ),

extraversion ( $\beta = 0.05$ ,  $p < 0.05$ ), openness to experience ( $\beta = -0.11$ ,  $p < 0.001$ ), agreeableness ( $\beta = 0.05$ ,  $p < 0.05$ ), and neuroticism ( $\beta = -0.06$ ,  $p < 0.01$ ) predicted indegree centrality. Self-monitoring ( $\beta = 0.16$ ,  $p < 0.001$ ), openness to experience ( $\beta = 0.08$ ,  $p < 0.001$ ), and conscientiousness ( $\beta = 0.04$ ,  $p < 0.05$ ) predicted brokerage. Indegree centrality had significant effects on job performance ( $\beta = 0.13$ ,  $p < 0.001$ ) and career success ( $\beta = 0.11$ ,  $p < 0.001$ ), but brokerage failed to predict these two outcomes. Further, direct relations between personality and the outcomes persisted after taking people’s network positions into account. Job performance was higher for people scoring higher on conscientiousness ( $\beta = 0.20$ ,  $p < 0.001$ ), self-monitoring ( $\beta = 0.05$ ,  $p < 0.05$ ), and openness to experience ( $\beta = 0.04$ ,  $p < 0.05$ ). Career success was greater for people scoring higher on extraversion ( $\beta = 0.13$ ,  $p < 0.001$ ), lower on agreeableness ( $\beta = -0.19$ ,  $p < 0.001$ ), and lower on neuroticism ( $\beta = -0.16$ ,  $p < 0.001$ ).

As shown in Figure 2, the pattern of results for instrumental networks mirrors those for expressive networks. Self-monitoring ( $\beta = 0.15$ ,  $p < 0.001$ ), extraversion ( $\beta = 0.04$ ,  $p < 0.05$ ), conscientiousness ( $\beta = 0.05$ ,  $p < 0.05$ ), and neuroticism ( $\beta = -0.10$ ,  $p < 0.001$ ) predicted indegree centrality. Self-monitoring ( $\beta = 0.04$ ,  $p < 0.05$ ), extraversion ( $\beta = 0.10$ ,  $p < 0.001$ ), conscientiousness ( $\beta = 0.10$ ,  $p < 0.001$ ), and agreeableness ( $\beta = -0.04$ ,  $p < 0.05$ ) predicted brokerage. In turn, indegree centrality predicted job performance and career success (both with  $\beta = 0.17$ ,  $p < 0.001$ ). Brokerage predicted career success ( $\beta = 0.06$ ,  $p < 0.01$ ). Further, direct relations between personality and outcomes persisted after taking people’s network positions into

Figure 1 Meta-Analytic Path Model for Personality, Expressive Network Position, and Work Outcomes

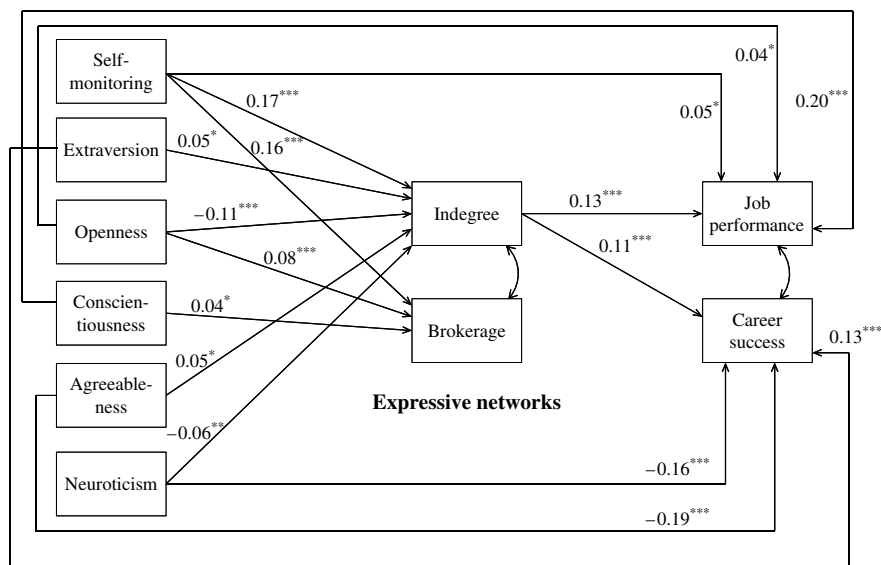

Notes. Harmonic mean sample size = 2,199. Path coefficients that were nonsignificant were fixed to zero, and these paths are omitted from the figure. The model fit after fixing these paths to zero is  $\chi^2 = 10.87$ ,  $df = 10$ ,  $p > 0.36$ , CFI = 1.00, TLI = 1.00, and RMSEA = 0.006.

\* $p < 0.05$ ; \*\* $p < 0.01$ ; \*\*\* $p < 0.001$ .

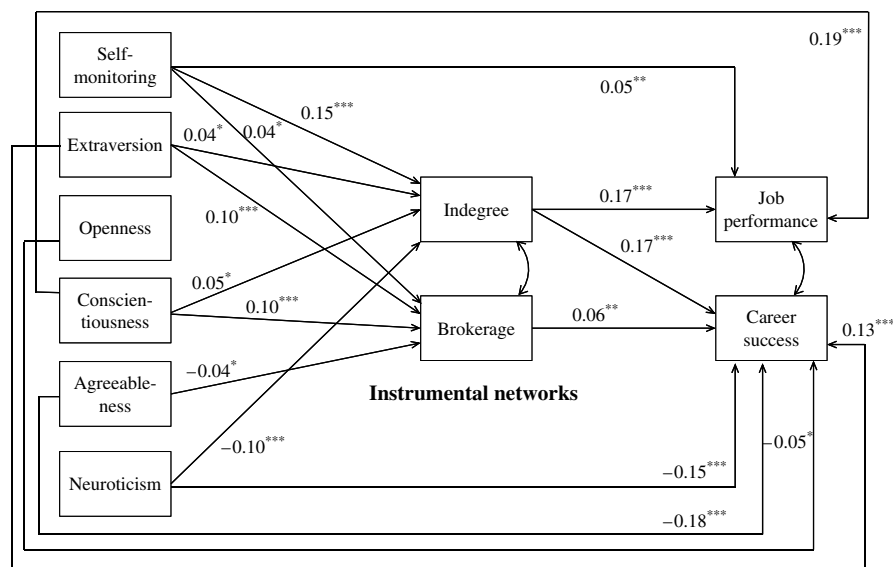
**Figure 2** Meta-Analytic Path Model for Personality, Instrumental Network Position, and Work Outcomes

Notes. Harmonic mean sample size = 2,720. Path coefficients that were nonsignificant were fixed to zero, and these paths are omitted from the figure. The model fit after fixing these paths to zero is  $\chi^2 = 14.93$ ,  $df = 11$ ,  $p > 0.18$ ,  $CFI = 1.00$ ,  $TLI = 0.99$ , and  $RMSEA = 0.011$ .

\* $p < 0.05$ ; \*\* $p < 0.01$ ; \*\*\* $p < 0.001$ .

account. Specifically, job performance was higher for people scoring higher on conscientiousness ( $\beta = 0.19$ ,  $p < 0.001$ ) and self-monitoring ( $\beta = 0.05$ ,  $p < 0.01$ ); career success was greater for people scoring higher on extraversion ( $\beta = 0.13$ ,  $p < 0.001$ ), lower on openness to experience ( $\beta = -0.05$ ,  $p < 0.05$ ), lower on agreeableness ( $\beta = -0.18$ ,  $p < 0.001$ ), and lower on neuroticism ( $\beta = -0.15$ ,  $p < 0.001$ ).

To examine whether network position mediated the relationship between personality and work outcomes, we conducted a series of mediation tests (MacKinnon 2008; MacKinnon et al. 2002). Table 3 shows evidence for partial mediation for several personality variables in expressive and instrumental networks. In terms of job performance, personality characteristics (i.e., self-monitoring, openness to experience, and conscientiousness) had both direct and mediated effects (via indegree centrality) on work outcomes. For example, the effect of self-monitoring on job performance was partially mediated by indegree centrality in both expressive and instrumental networks, as the first column in Table 3 indicates. In terms of career success, the pattern of results also showed evidence of partial mediation such that some personality characteristics (i.e., neuroticism, agreeableness, and extraversion) had both direct and mediated effects via network positions. For example, the negative effect of neuroticism on career success was partially mediated by indegree centrality in expressive and instrumental networks.

If the outlier study that concerned only instrumental networks (Gargiulo et al. 2009) was included in the analysis presented in Figure 2, then the harmonic mean sample size becomes 2,738. With the inclusion of this outlier

study, changes in Figure 2 are that (1) the indegree–career success path coefficient becomes 0.34 ( $p < 0.001$ ), and (2) the brokerage–career success path coefficient becomes nonsignificant ( $\beta = -0.02$ ,  $p > 0.30$ ). All other coefficients in Figure 2 remained unchanged. Thus, our overall conclusion of the partially mediated relationships remains the same for instrumental networks.

We also checked for evidence of an alternative to the partial mediation model: perhaps personality had no direct effects on outcomes but only affected performance and career success by facilitating the movement of people into advantageous social network positions (see Burt 2012). In testing this alternative approach (i.e., full mediation model), we found that constraining the paths between personality and outcomes to zero resulted in models with significantly poorer fit to the data than the partial mediation models ( $\Delta\chi^2 = 210.73$ ,  $\Delta df = 6$ ,  $p < 0.001$  for expressive networks;  $\Delta\chi^2 = 891.65$ ,  $\Delta df = 11$ ,  $p < 0.001$  for instrumental networks).

In summary, our overall findings across expressive and instrumental networks support a partial mediation model among personality, network position, and work outcomes. Our findings suggest that personality indirectly influences performance and career success by facilitating individuals' occupation of advantageous positions in organizational networks but that there is also a direct effect of personality on the performance outcomes above and beyond the mediated effects via advantageous network positions.

## Discussion

There has been a structural hole between network scholars who focus on social ties and researchers who focus

**Table 3 Mediated and Direct Effects of Personality on Work Outcomes**

	Job performance			Career success		
	Effect mediated by indegree	Effect mediated by brokerage	Direct effect	Effect mediated by indegree	Effect mediated by brokerage	Direct effect
Expressive networks						
<i>Self-monitoring</i>	0.02*** (0.01, 0.03)	—	0.05* (0.01, 0.09)	0.02*** (0.01, 0.03)	—	—
<i>Extraversion</i>	—	—	—	—	—	0.13*** (0.09, 0.17)
<i>Openness to experience</i>	-0.02*** (-0.02, -0.01)	—	0.04* (0.003, 0.09)	-0.01** (-0.02, -0.01)	—	—
<i>Conscientiousness</i>	—	—	0.20*** (0.16, 0.24)	—	—	—
<i>Agreeableness</i>	0.01* (0.00, 0.01)	—	—	0.01* (0.00, 0.01)	—	-0.19*** (-0.23, -0.14)
<i>Neuroticism</i>	-0.01** (-0.01, -0.002)	—	—	-0.01* (-0.01, -0.002)	—	-0.16*** (-0.21, -0.12)
Instrumental networks						
<i>Self-monitoring</i>	0.03*** (0.02, 0.04)	—	0.05** (0.02, 0.09)	0.03*** (0.02, 0.03)	—	—
<i>Extraversion</i>	0.01 (0.00, 0.02)	—	—	0.01 (0.001, 0.01)	0.01* (0.00, 0.01)	0.13*** (0.09, 0.17)
<i>Openness to experience</i>	—	—	—	—	—	-0.05* (-0.09, -0.01)
<i>Conscientiousness</i>	0.01* (0.001, 0.02)	—	0.19*** (0.16, 0.23)	0.01* (0.001, 0.02)	0.01** (0.002, 0.01)	—
<i>Agreeableness</i>	—	—	—	—	-0.003 (-0.01, 0.00)	-0.18*** (-0.22, -0.14)
<i>Neuroticism</i>	-0.02*** (-0.02, -0.01)	—	—	-0.02*** (-0.02, -0.01)	—	-0.15*** (-0.19, -0.11)

Notes. Reported in parentheses are the 95% CIs. After adding the outlier study (Gargiulo et al. 2009) in the analysis, brokerage no longer served as a mediator in the instrumental networks path model.

\* $p < 0.05$ ; \*\* $p < 0.01$ ; \*\*\* $p < 0.001$ .

on the personalities of individuals (Kilduff and Tsai 2003). Our meta-analytic approach integrates these two research streams and provides a bridge across this disconnect. One of the main findings to emerge from our analyses is that individuals' personality characteristics and the positions they occupy within organizational social networks *both* matter for job performance and career success. In linking personality to network structure, our inclusion of the Big Five traits beyond self-monitoring enriches our understanding of who occupies structurally advantageous positions in organizational networks. Of relevance to theories of structural advantage, perhaps the most surprising finding is that indegree centrality in instrumental networks such as advice and workflow is a stronger predictor of performance and career success than is brokerage.

### Contributions to Research and Theory

Our meta-analysis has important theoretical insights for research on social networks and personality psychology. Our first contribution is to the literature on personality psychology relevant to social networks. We examined

the leading personality variables of relevance to social network research—self-monitoring and the Big Five traits—in predicting indegree centrality and brokerage. The overall pattern of results depicts high self-monitors (relative to low self-monitors) as garnering more indegree connections such that people approach them for both expressive resources (e.g., friendship) and instrumental resources (e.g., information and advice). High self-monitors are also more likely to hold brokerage positions bridging disconnected friends. Given the importance of indegree centrality and brokerage for performance and career success, self-monitoring emerges as an especially relevant personality variable in the prediction of networking behavior and individual success.

With respect to the Big Five traits, our results provide new evidence concerning the relationship between personality and social network outcomes. First, we found that extraverted people are more likely to hold brokerage positions in instrumental networks, but not in expressive networks. These differences suggest that aspects of extraversion, such as assertiveness and ambition, may be especially important for brokerage in instrumental

networks but inconsequential for brokerage in expressive networks. Second, in clarifying the link between openness to experience and friendship, we found that people higher in openness to experience tend to have smaller friendship networks, but they are also more likely to act as go-betweens connecting disconnected friends, suggesting that having diverse interests drives them to interact with people from different social circles for friendship. Third, we found that conscientious individuals are more likely to be approached for work-related advice and information and to bridge the flow of work-related information between people disconnected at work. This finding helps explain the well-established association between conscientiousness and job performance across occupations (see [Barrick et al. 2001](#)). Fourth, we found that neurotic people, who may be considered high-cost interaction partners, are less likely to be approached for friendship and advice.

Our overall findings highlight that self-monitoring is especially relevant for understanding why people differ in their acquisition of advantageous positions in social networks. The finding that self-monitoring played a significant role in predicting indegree centrality and brokerage after controlling for the Big Five traits extends prior studies that neglected to take into account the Big Five personality variables (e.g., [Mehra et al. 2001](#), [Sasovova et al. 2010](#)). As such, our meta-analysis provides further insights into self-monitoring theory by establishing this personality variable as a distinct construct from the Big Five traits in the field of social network research, thereby responding to a recent call in the management literature for self-monitoring to be differentiated from extraversion ([Dalal et al. 2015](#)). Further, our meta-analysis also advances knowledge concerning how the Big Five personality factors, which still receive limited scholarly attention in social network research, affect people's attainment of structurally advantageous network positions. Our findings extend prior work ([Klein et al. 2004](#)) that focused on indegree centrality within team friendship and advice networks. We found that three personality traits (openness to experience, extraversion, and conscientiousness) related positively to brokerage in expressive or instrumental networks. Overall, our meta-analysis on the personality–network position relationships suggests that it is important for researchers to broaden their examination of other personality variables, beyond self-monitoring, in linking to structurally advantageous network positions such as indegree centrality and brokerage.

One caveat, however, is that personality, as reflected in self-monitoring and the Big Five traits, contributed modestly to the prediction of indegree centrality and brokerage. The total amount of variance explained in these network outcomes ranged between 3% and 5%. The evidence suggests that organizational networks represent relatively strong situations with hierarchical structures,

workflow constraints, and job design restrictions ([Brass 1981, 1995](#)). Within these parameters, even modest amounts of explained variance can represent significant structural advantages (see [Prentice and Miller 1992](#)).

Our second contribution to the microfoundations of organizational networks is an empirical one: our meta-analysis indicates that indegree centrality emerges as a stronger predictor of job performance and career success than does brokerage. Our analyses take into account a wide literature on network position and individual success, reflecting a diverse pool of jobs, work settings, and demographics. By contrast, structural hole theory ([Burt 1992, 2005](#)), and the evidence upon which it is based, is often focused on managers whose careers benefit from timely access and movement of information and knowledge from one place to another. Considering the workforce more broadly, rather than focusing just on managers in the knowledge economy, it appears that people benefit more from having larger networks or being in receipt of resources from many others, rather than being in positions that span otherwise unconnected network clusters. Overall, theories of structural advantage are likely to be informed by our finding that the number of incoming ties in organizational social networks is a strong correlate of individual success in organizations and a stronger overall predictor than is brokerage.

Our third major contribution is to the integration of personality and network variables. We tested two models concerning how personality and network position relate to individual success. The first model posits that personality is unrelated to both performance and career success once individuals attain advantageous network positions. The second model incorporates two predictions: (a) that the individual's personality is related, in part, to the likelihood that the individual attains an advantageous network position and (b) that the individual's personality and the individual's network position directly affect both the individual's chances of performance and career success. This second model implies a partial mediation relationship. In this meta-analysis, we ask, which model best fits the data?

Interpreting the overall pattern of findings, we generally found support for the second model—personality helps individuals move into advantageous network positions, and both personality tendencies and network positions relate to performance and career success. The overall tests of relative model fit showed that the data represented a better fit with the second model. We also found that both personality and network position were each incremental predictors of performance and career success, as shown by the significant paths from these predictors to the outcome variables (see [Figures 1 and 2](#)). Personality explained unique variance in performance and career success not captured by network position, and vice versa. Further, the results of the specific mediation tests showed that, in approximately half of

the cases, network position partially mediated the relationship between personality and work outcomes. For example, high self-monitors and conscientious people performed better at work not only because of the direct influence of their personality characteristics on performance but also because of these tendencies helping them move into advantageous network positions (e.g., indegree centrality), which in turn enhanced their performance. The overall pattern of results supports a partially mediated model for the relationships among personality, network position, and work outcomes.

The meta-analysis emphasizes the importance of integrating network structure and personality into examinations of performance outcomes. Network scholars, who work within the structural legacy, have largely neglected the possibility that, beyond network positions, individual differences relate to performance outcomes. For example, Burt (2012) measured personality characteristics in terms of consistency of network behavior across roles that individuals play in online games. His results suggested that personality had no relation to work outcomes in the presence of network position. Our findings challenge this conclusion. Drawing on specific measures of individuals' personalities in work organizations, our meta-analysis shows evidence that personality (self-monitoring and the Big Five) and network position (indegree centrality and brokerage) both relate to job performance and career success and, further, that network position partially mediates certain relationships between personality and the performance outcomes. As such, our integration of personality and networks, built on 138 independent samples examining these links, provides additional insight concerning the pathways toward performance and career success in organizations.

### Limitations and Future Research

Our research has several limitations that point to directions for future research. First, given that many of the studies involve nonexperimental data, we are not able to offer strong inferences concerning causality among personality, network position, and work outcomes. Prior work on personality and social ties (e.g., Asendorpf and Wilpers 1998) and the genetic basis of personality (e.g., Yamagata et al. 2006) suggests that personality is likely to precede network position because of the former's relative stability. However, we recognize that specific facets of personality are known to change in response to relationship factors (Mund and Neyer 2014). Furthermore, it is also possible that individuals with higher performance and greater career success achieve more advantageous network positions. Future research is needed to better understand the causal direction of the relationships among network position, performance, and career success.

Second, we focused on self-monitoring and the most popular personality framework (i.e., the Big Five). However, other approaches may improve the predictive validity of personality. For example, lower-level "facets" of

each Big Five trait (Dudley et al. 2006) and "contextualized" measures of personality (Shaffer and Postlethwaite 2012) could have incremental predictive power over and above self-monitoring and the broad Big Five traits examined here. Future research should also focus on other individual difference variables (e.g., positive affectivity, negative affectivity, general cognitive ability, emotional intelligence, core self-evaluations, proactive personality) that may deserve empirical attention. For instance, in ancillary meta-analyses we found that, across expressive and instrumental networks, positive affectivity had significant and modest positive correlations with indegree centrality and brokerage ( $\rho$  ranged from 0.09 to 0.14), whereas negative affectivity had smaller, although significant, negative correlations with indegree centrality and brokerage ( $\rho$  ranged from  $-0.04$  to  $-0.08$ ).

Third, our research focused on indegree centrality and brokerage, two of the most studied network positions, for answering the three research questions. Future research could explore whether our findings hold for other structurally advantageous positions. For example, considering their differential effects on indegree centrality, we also examined whether self-monitoring and extraversion relate differently to the number of outgoing ties to others (i.e., outdegree centrality) in our ancillary meta-analytic regression analyses. We found that extraversion related positively to outdegree centrality across expressive and instrumental networks, whereas self-monitoring was unrelated to outdegree centrality in either type of social networks. This evidence suggests a key difference between self-monitoring and extraversion—high self-monitors tend to be sought out for advice and friendship, whereas extraverts tend to seek out others for advice and friendship.

Fourth, future research should consider the boundary conditions of the relationships studied here. We focused on expressive and instrumental networks as one potential moderator. But (as noted by an anonymous reviewer) other moderators, such as work characteristics (the extent of social interaction and task interdependence) and employees' hierarchical level in organizations, are also likely to be. In post hoc analyses, we did not find any consistent pattern of moderation for social interaction, task interdependence, and hierarchical level for either the personality–network position or the network–position–outcome relationships. Future research could explicitly measure work characteristics and hierarchical level for each individual and investigate their moderating effects across the personality–network position or the network–position–outcome relationships.

Fifth, we focused on a partial mediation model in answering the broad question on how personality and network position work together in relating to work outcomes. An alternative model (that we were unable to test because of the absence of information on correlations

with interaction terms) captures the *interaction* of personality and network position. This model has been suggested by several authors (e.g., Burt 2007, Kilduff and Brass 2010, Mehra et al. 2001) and has been examined in empirical work (e.g., Anderson 2008, Fang and Shaw 2009, Fang et al. 2015). We recommend that future research report zero-order correlations with the moderated regression terms to facilitate meta-analytic tests. In addition, in instrumental networks, our path modeling results showed that the coefficient of the path from brokerage to career success became nonsignificant after including the outlier study (i.e., Gargiulo et al. 2009), which greatly increased the harmonic mean size as well as the coefficient of the path from indegree centrality to career success. Thus, we should be cautious in interpreting the mediating role played by brokerage in instrumental networks in the relationship of personality and work outcomes.

In conclusion, the findings of our meta-analysis show that it is pivotal to integrate both characteristics of individuals (e.g., self-monitoring and the Big Five) and their social network positions (e.g., indegree centrality and brokerage) into theory and research for a better understanding of how the personalities of people and their social networks matter for important work and career outcomes.

### Supplemental Material

Supplemental material to this paper is available at <http://dx.doi.org/10.1287/orsc.2015.0972>.

### Acknowledgments

The first two authors contributed equally to the paper. The authors thank Tiziana Casciaro, Sigal Barsade, David Krackhardt, and three anonymous reviewers for their helpful comments and suggestions on previous drafts. The authors also thank In-Sue Oh for his suggestions on meta-analytic procedures.

### Appendix. Primary Studies Included in Meta-Analysis

Below we list the studies included in our meta-analysis. Those with asterisks are also cited in the reference list.

\*Anderson MH (2008) Social networks and the cognitive motivation to realize network opportunities: A study of managers' information gathering behaviors. *J. Organ. Behav.* 29:51–78.

Anderson MH (2012) Team member traits and capabilities, social capital, and transactive memory development. Working paper, Iowa State University, Ames.

Anderson MH, Haar J (2012) Individual differences, social capital, and organizational behavior outcomes. Working paper, Iowa State University, Ames.

\*Asendorpf JB, Wilpers S (1998) Personality effects in social relationships. *J. Personality Soc. Psych.* 74:1531–1544.

Baer M (2010) The strength-of-weak-ties perspective on creativity. *J. Appl. Psych.* 95:592–601.

Bizzi L (2013a) The dark side of structural holes: A multilevel investigation. *J. Management* 39:1554–1578.

Bizzi L (2013b) The social structure of job crafting: Exploring the ambivalent nature of networks. *Acad. Management Proc.* 2013(Meeting abstract supplement):Abstract 13159.

Bono JE, Anderson MH (2003) Advice and influence networks of transformational leaders. Working paper, University of Minnesota, Minneapolis.

Brands RA, Kilduff M (2014) Just like a woman? Effects of gender-biased perceptions of friendship network brokerage on attributions and performance. *Organ. Sci.* 25:1530–1548.

\*Brass DJ (1984) Being in the right place: A structural analysis of individual influence in an organization. *Admin. Sci. Quart.* 29:518–539.

\*Burt RS (2007) Secondhand brokerage: Evidence on the importance of local structure for managers, bankers, and analysts. *Acad. Management J.* 50:119–148.

Burton PE (2007) Dimensions of social networks as predictors of employee performance. Doctoral dissertation, University of North Texas, Denton.

Carboni I, Casciaro T (2013) Love me or hate me: Performance effects of sociometric status in organizational networks. *Acad. Management Proc.* 2013(Meeting abstract supplement):Abstract 17033.

Carboni I, Ehrlich K (2013) The effect of relational and team characteristics on individual performance: A social network perspective. *Human Resource Management* 52:511–535.

Casciaro T (1998) Seeing things clearly: Social structure, personality, and accuracy in social network perception. *Soc. Networks* 20:331–351.

Choi K, Kim MJ (2014) Energizing networks and public sector employees' attitudes. *Acad. Management Proc.* 2014(Meeting abstract supplement):Abstract 13241.

Clement J, Shipilov AV, Galunic CD (2014) The making of brokers: When second-order brokerage leads to formation of neighborhood-spanning ties. *Acad. Management Proc.* 2014(Meeting abstract supplement):Abstract 11505.

\*Cross R, Cummings JN (2004) Tie and network correlates of individual performance in knowledge-intensive work. *Acad. Management J.* 47:928–937.

Dolgova E (2013) Fake it till you make it? The effect of self-monitoring and competence on friendship dynamics. *Acad. Management Proc.* 2013(Meeting abstract supplement):Abstract 13888.

Erdogan B, Bauer TN, Walter J (2015) Deeds that help and words that hurt: Helping and gossip as moderators of the relationship between leader–member exchange and advice network centrality. *Personnel Psych.* 68:185–214.

Fang R (2010) Peer influence on undermining behaviors in the workplace: A social network perspective. Doctoral dissertation, University of Minnesota, Minneapolis.

\*Fang R, Shaw JD (2009) Self-monitoring, status, and justice-related information flow. *J. Occupational Organ. Psych.* 82:405–430.

Fang R, Duffy MK, Shaw JD (2011) A multi-wave examination of social capital, core self-evaluations, and newcomer adjustment. Working paper, National University of Singapore, Singapore.

Flynn FJ, Reagans RE, Amanatullah ET, Ames DR (2006) Helping one's way to the top: Self-monitors achieve status by helping others and knowing who helps whom. *J. Personality Soc. Psych.* 91:1123–1137.

\*Gargiulo M, Ertug G, Galunic C (2009) Two faces of control: Network closure and individual performance among knowledge workers. *Admin. Sci. Quart.* 54:299–333.

Geletkanycz MA, Boyd BK, Finkelstein S (2001) The strategic value of CEO external directorate networks: Implications for CEO compensation. *Strategic Management J.* 22:889–898.

Grosser TJ (2014) The effect of political skill and social network structure on innovation and career success. *Acad. Management Proc.* 2014(Meeting abstract supplement):Abstract 10650.

Ho VT, Pollack JM (2014) Passion isn't always a good thing: Examining entrepreneurs' network centrality and financial performance with a dualistic model of passion. *J. Management Stud.* 51:433–459.

Hopp C, Zenk L (2012) Collaborative team networks and implications for strategic human resource management. *Internat. J. Human Resource Management* 23:2975–2994.

\*Kalish Y, Robins G (2006) Psychological predispositions and network structure: The relationship between individual predispositions, structural holes and network closure. *Soc. Networks* 28:56–84.

Kilduff M (1988) Decision making in context: Social and personality correlates of choices in organizations. Doctoral dissertation, Cornell University, Ithaca, NY.

Kim E, Bhawe D (2012) Too smart for your own good? Cognitive ability, personality, and network centrality. Working paper, Georgia Institute of Technology, Atlanta.

\*Klein KJ, Lim B, Saltz JL, Mayer DM (2004) How do they get there? An examination of the antecedents of centrality in team network. *Acad. Management J.* 47:952–963.

Kleinbaum AM, Jordan A, Audia PG (2013) Do you read me? How perceptions of empathy shape self-monitors' brokerage in social networks. *Acad. Management Proc.* 2013(Meeting abstract supplement):Abstract 10950.

Lau DC (2001) Job consequences of trustworthy employees: A social network analysis. Doctoral dissertation, University of Hong Kong, Hong Kong.

Lee YH, Yang LS, Wan KM, Chen GH (2010) Interactive effects of personality and friendship networks on contextual performance. *Soc. Behav. Personality* 38:197–208.

Liu Y, Ipe M (2010) How do they become nodes? Revisiting team member network centrality. *J. Psych.* 144:243–258.

Luria G, Kalish Y (2013) A social network approach to peer assessment: Improving predictive validity. *Human Resource Management* 52:537–560.

Marrone JA (2004) Cutting across team boundaries: Antecedents and implications of individual boundary spanning behavior within consulting teams. Doctoral dissertation, University of Maryland, College Park.

McFadyen MA, Cannella AA Jr (2004) Social capital and knowledge creation: Diminishing returns of the number and strength of exchange relationships. *Acad. Management J.* 47:735–746.

\*Mehra A, Kilduff M, Brass DJ (2001) The social networks of high and low self-monitors: Implications for workplace performance. *Admin. Sci. Quart.* 46:121–146.

Merluzzi JM (2014) The myth of the queen bee: A study and gender and work conflict at two firms. *Acad. Management Proc.* 2014(Meeting abstract supplement):Abstract 11654.

Milton LP, Westphal JD (2005) Identity confirmation networks and cooperation in work groups. *Acad. Management J.* 48:191–212.

Miners CTH (2008) It is who you know and what you know: An examination of the relations among emotional intelligence, social network centrality, and performance. Doctoral dissertation, University of Toronto, Toronto.

Moore GJ (2006) The longitudinal effects of self-monitoring and locus of control on social network position in friendship networks. Master's thesis, Air Force Institute of Technology, Wright-Patterson Air Force Base, OH.

Neubert MJ, Taggar S (2004) Pathways to informal leadership: The moderating role of gender on the relationship of individual differences and team member network centrality to informal leadership emergence. *Leadership Quart.* 15:175–194.

Neuman EJ, Avgar AC (2013) A bridge over troubled water? The push and pull of team conflict on between-team network

ties. *Acad. Management Proc.* 2013(Meeting abstract supplement): Abstract 15003.

\*Oh H, Kilduff M (2008) The ripple effect of personality on social structure: Self-monitoring origins of network brokerage. *J. Appl. Psych.* 93:1155–1164.

Oldroyd JB (2007) The burdens and benefits of information flow: Social structure, interdependence, information flow and performance. Doctoral dissertation, Northwestern University, Evanston, IL.

\*Pollet TV, Roberts SGB, Dunbar RIM (2011) Extraverts have larger social network layers: But do not feel emotionally closer to individuals at any layer. *J. Individual Differences* 32:161–169.

\*Sasovova Z, Mehra A, Borgatti SP, Schippers MC (2010) Network churn: The effects of self-monitoring personality on brokerage dynamics. *Admin. Sci. Quart.* 55:639–670.

Schulte, M, Cohen NA, Klein KJ (2012) The coevolution of network ties and perceptions of team psychological safety. *Organ. Sci.* 23:564–581.

Scott BA (2007) Employee popularity: Its nature, measurement, and organizational relevance. Doctoral dissertation, University of Florida, Gainesville.

\*Seibert SE, Kraimer ML, Liden RC (2001) A social capital theory of career success. *Acad. Management J.* 44:219–237.

\*Selfhout M, Burk W, Branje S, Denissen J, van Aken M, Meeus W (2010) Emerging late adolescent friendship networks and Big Five personality traits: A social network approach. *J. Personality* 78: 509–538.

Setton RP, Mossholder KW (2002) Relationship quality and relationship context as antecedents of person- and task-focused interpersonal citizenship behavior. *J. Appl. Psych.* 87:255–267.

\*Shaw JD, Duffy MK, Johnson JL, Lockhart DE (2005) Turnover, social capital losses, and performance. *Acad. Management J.* 48: 594–606.

Shea C, Fitzsimons G (2012) A goal driven view of social network structure. Working paper, Duke University, Durham, NC.

Shum C, Zhou L, Carter DR, Mo S, Chen H (2014) Influence of subordinates' and supervisors' network positions on the effect of abusive supervision. *Acad. Management Proc.* 2014(Meeting abstract supplement):Abstract 15652.

\*Sparrowe RT, Liden RC, Wayne SJ, Kraimer ML (2001) Social networks and the performance of individuals and groups. *Acad. Management J.* 44:316–325.

Tasselli S (2013) Network structure, individual agency and outcomes: Power dynamics following a change in technology. *Acad. Management Proc.* 2013(Meeting abstract supplement):Abstract 13039.

\*Toegel G, Anand N, Kilduff M (2007) Emotion helpers: The role of high positive affectivity and high self-monitoring managers. *Personnel Psych.* 60:337–365.

Totterdell P, Holman D, Hukin A (2008) Social networks: Measuring and examining individual differences in propensity to connect with others. *Soc. Networks* 30:283–296.

Totterdell P, Wall T, Holman D, Diamond H, Epitropaki O (2004) Affect networks: A structural analysis of the relationship between work ties and job-related affect. *J. Appl. Psych.* 89:845–867.

Venkataramani V, Green SG, Schleicher DJ (2010) Well-connected leaders: The impact of leaders' social network ties on LMX and members' work attitudes. *J. Appl. Psych.* 95:1071–1084.

Wang L, Kishore R, Balkundi P (2012) Knowledge network evolution: A cross-level study of individual antecedents and team learning effectiveness. Working paper, State University of New York at Buffalo, Buffalo.



Wei J, Zheng W (2012) Linking motivation to social capital: The roles of regulatory focus and self-monitoring. *Acad. Management Proc. 2012*(Meeting abstract supplement):Abstract 15619.

Wisker ZL (2011) The effect of personality, emotional intelligence, and social network characteristics on sales performance: The mediating roles of market intelligence use, adaptive selling behaviour, and improvisation. Doctoral dissertation, University of Waikato, Hamilton, New Zealand.

Xiao Z, Tsui AS (2007) When brokers may not work: The cultural contingency of social capital in Chinese high-tech firms. *Admin. Sci. Quart. 52*:1–31.

Yuan YC, Gay G (2006) Homophily and network ties and bonding and bridging social capital in computer-mediated distributed teams. *J. Comput.-Mediated Comm. 11*:1062–1084.

\*Zhang Z, Peterson SJ (2011) Advice networks in teams: The role of transformational leadership and members' core self-evaluations. *J. Appl. Psych. 96*:1004–1017.

Zhang M, Wei J (2014) The contingent value of centrality on individual performance: A multi-level analysis. *Acad. Management Proc. 2014*(Meeting abstract supplement):Abstract 14465.

Zou X (2009) Social networks and subjective well-being: Regulatory focus between self-regulation and network structure. Doctoral dissertation, Columbia University, New York.

## References

Anderson MH (2008) Social networks and the cognitive motivation to realize network opportunities: A study of managers' information gathering behaviors. *J. Organ. Behav. 29*:51–78.

Asendorpf JB, Wilpers S (1998) Personality effects in social relationships. *J. Personality Soc. Psych. 74*:1531–1544.

Ashton MC, Lee K, Pauson SV (2002) What is the central feature of extraversion? Social attention versus reward sensitivity. *J. Personality Soc. Psych. 83*:245–252.

Baldwin TT, Bedell MD, Johnson JL (1997) The social fabric of a team-based M.B.A. program: Network effects on student satisfaction and performance. *Acad. Management J. 40*:1369–1397.

Balkundi P, Kilduff M, Harrison DA (2011) Centrality and charisma: comparing how leader networks and attributions affect team performance. *J. Appl. Psych. 96*:1209–1222.

Barrick MR, Mount MK, Judge TA (2001) Personality and performance at the beginning of the new millennium: What do we know and where do we go next? *Internat. J. Selection Assess. 9*:9–30.

Barrick MR, Stewart GL, Piotrowski M (2002) Personality and job performance: Test of the mediating effects of motivation among sales representatives. *J. Appl. Psych. 87*:43–51.

Baron RA (1989) Personality and organizational conflict: Effects of the type A behavior pattern and self-monitoring. *Organ. Behav. Human Decision Processes 44*:281–296.

Beal DJ, Corey DM, Dunlap WP (2002) Identifying outlier studies in meta-analysis: Alternatives to Huffcutt and Arthur's 1995 approach. *J. Appl. Psych. 87*:583–589.

Bendersky C, Shah NP (2013) The downfall of extraverts and the rise of neurotics: The dynamic process of status allocation in task groups. *Acad. Management J. 56*:387–406.

Bono JE, Judge TA (2004) Personality and transformational and transactional leadership: A meta-analysis. *J. Appl. Psych. 89*:901–910.

Bossard JH (1945) The law of family interaction. *Amer. J. Sociol. 50*:292–294.

Brass DJ (1981) Structural relationships, job characteristics, and worker satisfaction and performance. *Admin. Sci. Quart. 26*:331–348.

Brass DJ (1984) Being in the right place: A structural analysis of individual influence in an organization. *Admin. Sci. Quart. 29*:518–539.

Brass DJ (1995) A social network perspective on human resources management. *Res. Personnel and Human Resources Management 31*:39–79.

Brass DJ, Burkhardt ME (1993) Potential power and power use: An investigation of structure and behavior. *Acad. Management J. 36*:441–470.

Burkhardt ME, Brass DJ (1990) Changing patterns or patterns of change: The effect of a change in technology on social network structure and power. *Admin. Sci. Quart. 35*:104–127.

Burt RS (1992) *Structural Holes: The Social Structure of Competition* (Harvard University Press, Cambridge, MA).

Burt RS (2005) *Brokerage and Closure* (Oxford University Press, New York).

Burt RS (2007) Secondhand brokerage: Evidence on the importance of local structure for managers, bankers, and analysts. *Acad. Management J. 50*:119–148.

Burt RS (2012) Network-related personality and the agency question: Multi-role evidence from a virtual world. *Amer. J. Sociol. 118*:543–591.

Burt RS, Jannotta JE, Mahoney JT (1998) Personality correlates of structural holes. *Soc. Networks 20*:63–87.

Burt RS, Kilduff M, Tasselli S (2013) Social network analysis: Foundations and Frontiers on advantage. *Annual Rev. Psych. 64*:527–547.

Cheng C, Bond MH, Chan SC (1995) The perception of ideal best friends by Chinese adolescents. *Internat. J. Psych. 30*:91–108.

Chiaburu DS, Oh IS, Berry CM, Li N, Gardner RG (2011) The five-factor model of personality traits and organizational citizenship behaviors: A meta-analysis. *J. Appl. Psych. 96*:1140–1166.

Cross R, Cummings JN (2004) Tie and network correlates of individual performance in knowledge-intensive work. *Acad. Management J. 47*:928–937.

Dabbs JM, Evans MS, Hopper CH, Purvis JA (1980) Self-monitors in conversation: What do they monitor? *J. Personality Soc. Psych. 39*:278–284.

Dalal RS, Meyer RD, Bradshaw RP, Green JP, Kelly ED, Zhu M (2015) Personality strength and situational influences on behavior: A conceptual review and research agenda. *J. Management 41*:261–287.

Day DV, Schleicher DJ, Unckless AL, Hiller NJ (2002) Self-monitoring personality at work: A meta-analytic investigation of construct validity. *J. Appl. Psych. 87*:390–401.

Denissen JJA, Penke L (2008) Neuroticism predicts reactions to cues of social inclusion. *Eur. J. Personality 22*:497–517.

De Pascalis V, Arwari B, Matteucci M, Mazzocco A (2005) Effects of emotional visual stimuli on auditory information processing: A test of J.A. Gray's reinforcement sensitivity theory. *Personality Individual Differences 38*:163–176.

Digman JM (1990) Personality structure: Emergence of the five-factor model. *Annual Rev. Psych. 41*:417–440.

Dudley NM, Orvis KA, Lebiecki JE, Cortina JM (2006) A meta-analytic investigation of conscientiousness in the prediction of job performance: Examining the intercorrelations and the incremental validity of narrow traits. *J. Appl. Psych. 91*:40–57.

Emerson RM (1962) Power-dependence relations. *Amer. Sociol. Rev. 27*:31–41.

Fang R, Shaw JD (2009) Self-monitoring, status, and justice-related information flow. *J. Occupational Organ. Psych. 82*:405–430.

Fang R, Chi L, Chen M, Baron RA (2015) Bringing political skill into social networks: Findings from a field study of entrepreneurs. *J. Management Stud. 52*:175–212.

- Fleeson W, Gallagher P (2009) The implications of big five standing for the distribution of trait manifestation in behavior: Fifteen experience-sampling studies and a meta-analysis. *J. Personality Soc. Psych.* 97:1097–1114.
- Freeman LC (1979) Centrality in social networks: Conceptual clarification. *Soc. Networks* 1:215–239.
- Freeman LC, Roeder D, Mulholland RR (1980) Centrality in social networks, II: Experimental results. *Soc. Networks* 2:119–141.
- Fuglestad PT, Snyder M (2010) Status and motivational foundations of self-monitoring. *Soc. Personality Psych. Compass* 4: 1031–1041.
- Furnham A, Capon M (1983) Social skills and self-monitoring processes. *Personality Individual Differences* 4:171–178.
- Gargiulo M, Ertug G, Galunic C (2009) Two faces of control: Network closure and individual performance among knowledge workers. *Admin. Sci. Quart.* 54:299–333.
- Gibbons DE (2004) Friendship and advice networks in the context of changing professional values. *Admin. Sci. Quart.* 49:238–262.
- Hinds PJ, Carley KM, Krackhardt D, Wholey D (2000) Choosing work group members: Balancing similarity, competence, and familiarity. *Organ. Behav. Human Decision Processes* 81: 226–251.
- Holmes JG (2002) Interpersonal expectations as the building blocks of social cognition: An interdependence theory perspective. *Personal Relationships* 9:1–26.
- Hough LM, Ones DS (2001) The structure, measurement, validity, and use of personality variables in industrial, work, and organizational psychology. Anderson N, Ones DS, Sinagil HK, Viswesvaran C, eds. *Handbook of Industrial, Work and Organizational Psychology*, Vol. 1 (Sage, London), 233–277.
- Huffcutt AI, Arthur W (1995) Development of a new outlier statistic for meta-analytic data. *J. Appl. Psych.* 80:327–334.
- Hunter JE, Schmidt FL (2004) *Methods of Meta-Analysis: Correcting Error and Bias in Research Findings*, 2nd ed. (Sage, Thousand Oaks, CA).
- Hunter JE, Schmidt FL, Jackson GB (1982) *Meta-Analysis: Cumulating Research Findings Across Studies* (Sage, Beverly Hills, CA).
- Ickes WJ, Reidhead S, Patterson M (1986) Machiavellianism and self-monitoring: As different as “me” and “you.” *Soc. Cognition* 4:58–74.
- Jensen-Campbell LA, Gleason KA, Adams R, Malcolm KT (2003) Interpersonal conflict, agreeableness, and personality development. *J. Personality* 71:1059–1086.
- Johnson JW (2000) A heuristic method for estimating the relative weight of predictor variables in multiple regression. *Multivariate Behav. Res.* 35:1–19.
- Judge TA, Heller D, Mount MK (2002) Five-factor model of personality and job satisfaction: A meta-analysis. *J. Appl. Psych.* 87:530–541.
- Judge TA, Simon LS, Hurst C, Kelley K (2014) What I experienced yesterday is who I am today: Relationship of work motivations and behaviors to within-individual variation in the five-factor model of personality. *J. Appl. Psych.* 99:199–221.
- Kalish Y, Robins G (2006) Psychological predispositions and network structure: The relationship between individual predispositions, structural holes and network closure. *Soc. Networks* 28:56–84.
- Kashdan TB, McKnight PE, Fincham FD, Rose P (2011) When curiosity breeds intimacy: Taking advantage of intimacy opportunities and transforming boring conversations. *J. Personality* 79:1369–1402.
- Kilduff M, Brass DJ (2010) Organizational social network research: Core ideas and key debates. *Acad. Management Ann.* 4:317–357.
- Kilduff M, Krackhardt D (1994) Bringing the individual back in: A structural analysis of the internal market for reputation in organizations. *Acad. Management J.* 37:87–108.
- Kilduff M, Tsai W (2003) *Social Networks and Organizations* (Sage, London).
- Klein KJ, Lim B, Saltz JL, Mayer DM (2004) How do they get there? An examination of the antecedents of centrality in team network. *Acad. Management J.* 47:952–963.
- Kleinbaum AM (2012) Organizational misfits and the origins of brokerage in intrafirm networks. *Admin. Sci. Quart.* 57:407–452.
- Knocke D, Burt RS (1983) Prominence. Burt RS, Miner MJ, eds. *Applied Network Analysis: A Methodological Introduction* (Sage, Beverly Hills, CA), 195–222.
- Lennox RD, Wolfe RN (1984) Revision of the self-monitoring scale. *J. Personality Soc. Psych.* 46:1349–1364.
- MacKinnon DP (2008) *Introduction to Statistical Mediation Analysis* (Routledge, New York).
- MacKinnon DP, Lockwood CM, Hoffman JM, West SG, Sheets V (2002) A comparison of methods to test mediation and other intervening variable effects. *Psych. Methods* 7:83–104.
- McCrae RR (1996) Social consequences of experiential openness. *Psych. Bull.* 120:323–337.
- McCrae RR, John OP (1992) An introduction to the five-factor model and its applications. *J. Personality* 60:175–215.
- Mehra A, Kilduff M, Brass DJ (2001) The social networks of high and low self-monitors: Implications for workplace performance. *Admin. Sci. Quart.* 46:121–146.
- Mund M, Neyer FJ (2014) Treating personality-relationship transactions with respect: Narrow facets, advanced models, and extended time frames. *J. Personality Soc. Psych.* 107:352–368.
- Nettle D (2006) The evolution of personality variation in humans and other animals. *Amer. Psychologist* 61:622–631.
- Ng TWH, Eby LT, Sorensen KL, Feldman DC (2005) Predictors of objective and subjective career success: A meta-analysis. *Personnel Psych.* 58:367–408.
- O’Boyle EH Jr, Forsyth DR, Banks GC, McDaniel MA (2012) A meta-analysis of the dark triad and work behavior: A social exchange perspective. *J. Appl. Psych.* 97:557–579.
- Oh H, Kilduff M (2008) The ripple effect of personality on social structure: Self-monitoring origins of network brokerage. *J. Appl. Psych.* 93:1155–1164.
- Pollet TV, Roberts SGB, Dunbar RIM (2011) Extraverts have larger social network layers: But do not feel emotionally closer to individuals at any layer. *J. Individual Differences* 32:161–169.
- Prentice DA, Miller DT (1992) When small effects are impressive. *Psych. Bull.* 112:160–164.
- Sasovova Z, Mehra A, Borgatti SP, Schippers MC (2010) Network churn: The Effects of self-monitoring personality on brokerage dynamics. *Admin. Sci. Quart.* 55:639–670.
- Seibert SE, Kraimer ML, Liden RC (2001) A social capital theory of career success. *Acad. Management J.* 44:219–237.
- Selfhout M, Burk W, Branje S, Denissen J, van Aken M, Meeus W (2010) Emerging late adolescent friendship networks and Big Five personality traits: A social network approach. *J. Personality* 78:509–538.
- Shaffer JA, Postlethwaite BE (2012) A matter of context: A meta-analytic investigation of the relative validity of contextualized and noncontextualized personality measures. *Personnel Psych.* 65:445–494.
- Shaffer DR, Smith JE, Tomarelli M (1982) Self-monitoring as a determinant of self-disclosure reciprocity during the acquaintance process. *J. Personality Soc. Psych.* 43:163–175.
- Shaw JD, Duffy MK, Johnson JL, Lockhart DE (2005) Turnover, social capital losses, and performance. *Acad. Management J.* 48:594–606.

- Snyder M (1974) The self-monitoring of expressive behavior. *J. Personality Soc. Psych.* 30:526–537.
- Snyder M (1979) Self-monitoring processes. Berkowitz L, ed. *Advances in Experimental Social Psychology*, Vol. 12 (Academic Press, New York), 85–128.
- Snyder M (1987) *Public Appearances, Private Realities: The Psychology of Self-Monitoring* (W. H. Freeman & Company, San Francisco).
- Snyder M, Gangestad S, Simpson JA (1983) Choosing friends as activity partners: The role of self-monitoring. *J. Personality Soc. Psych.* 51:181–190.
- Sparrowe RT, Liden RC, Wayne SJ, Kraimer ML (2001) Social networks and the performance of individuals and groups. *Acad. Management J.* 44:316–325.
- Stokes RC (1985) The effects of price, package design, and brand familiarity on perceived quality. Jacoby J, Olson J, eds. *Perceived Quality: How Consumers View Stores and Merchandise* (Lexington Books, Lexington, MA), 233–246.
- Stovel K, Shaw L (2012) Brokerage. *Annual Rev. Sociol.* 38:139–158.
- Toegel G, Anand N, Kilduff M (2007) Emotion helpers: The role of high positive affectivity and high self-monitoring managers. *Personnel Psych.* 60:337–365.
- Turner RG (1980) Self-monitoring and humor production. *J. Personality* 48:163–172.
- Viswesvaran C, Ones DS (1995) Theory testing: Combining psychometric meta-analysis and structural equations modelling. *Personnel Psych.* 48:865–885.
- Wasserman S, Faust K (1994) *Social Network Analysis: Methods and Applications* (Cambridge University Press, Cambridge, UK).
- Whitener EM (1990) Confusion of confidence intervals and credibility intervals in meta-analysis. *J. Appl. Psych.* 75:315–321.
- Yamagata S, Suzuki A, Ando J, Ono Y, Kijima N, Yoshimura K, Ostendorf F, et al. (2006) Is the genetic structure of human personality universal? A cross-cultural twin study from North America, Europe, and Asia. *J. Personality Soc. Psych.* 90:987–998.
- Zhang Z, Peterson SJ (2011) Advice networks in teams: The role of transformational leadership and members' core self-evaluations. *J. Appl. Psych.* 96:1004–1017.
- Zhao H, Seibert SE (2006) The big five personality dimensions and entrepreneurial status: A meta-analytical review. *J. Appl. Psych.* 91:259–271.
- Zimmerman RD (2008) Understanding the impact of personality traits on individuals' turnover decisions: A meta-analytic path model. *Personnel Psych.* 61:309–348.

**Ruolian Fang** is assistant professor in management and organization at NUS Business School, National University of Singapore. She received her Ph.D. from the University of Minnesota. Her research interests include social networks, newcomer socialization, workplace deviant behavior, and entrepreneurship.

**Blaine Landis** is postdoctoral research fellow in organizational behavior at University College London. He received his Ph.D. from the University of Cambridge. His research focuses on the psychology of individuals' social networks in organizations.

**Zhen Zhang** is associate professor of management at the W. P. Carey School of Business, Arizona State University. He received his Ph.D. from the University of Minnesota. His research concentrates on leadership processes and leadership development, the biological basis of work behavior, and research methods.

**Marc H. Anderson** is associate professor in management at the College of Business at Iowa State University. He received his Ph.D. from the University of Minnesota. His research interests include the effects of personality, social networks, and their interaction on organizational behavior, leadership, managerial and organizational cognition, sensemaking, and timing.

**Jason D. Shaw** is chair professor and codirector of the Centre for Leadership and Innovation at the Hong Kong Polytechnic University. He received his Ph.D. from the University of Arkansas. His research interests include team effectiveness, employment relationships, envy, financial incentives, and turnover.

**Martin Kilduff** is professor of organizational behavior in the Management Science and Innovation department, University College London. He received his Ph.D. from Cornell University. His research focuses on the microfoundations and consequences of individuals' social networks, with particular emphasis on the role of personality, cognition, and emotion in these processes.

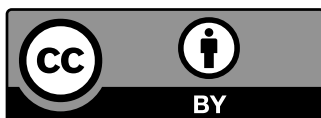

This work is licensed under a Creative Commons Attribution 4.0 International License. You are free to copy, distribute, transmit and adapt this work, but you must attribute this work as “*Organization Science*. Copyright 2015 INFORMS. <http://dx.doi.org/10.1287/orsc.2015.0972>, used under a Creative Commons Attribution License: <http://creativecommons.org/licenses/by/4.0/>.”