

**THE SYNTAX
OF
GREEK POLYDEFINITES**

NIKOLAOS VELEGRAKIS

Thesis submitted in partial fulfilment of the requirements for the degree of
Doctor of Philosophy in Linguistics

U C L

2 0 1 1

DECLARATION

I, Nikolaos Velegrakis, confirm that the work presented in this thesis is my own.
Where information has been derived from other sources, I confirm that this has been indicated in the thesis.

.....

Hans van de Koot – Advisor

Ad Neeleman – Co-advisor

ABSTRACT

The thesis is concerned with the phenomenon of polydefiniteness in Greek. The term *polydefinite* refers to instances of adjectival modification in which the same definite determiner is multiply realized (*to pseftiko to chrisso to roloi* ‘the fake golden watch’). Polydefinites present free word order variation. It is argued that the construction should be syntactically analyzed on a par with close appositive DPs.

Both close appositives and polydefinites are associated with a structure of mutual adjunction, in which the top node inherits non-conflicting properties of both its daughters. The word-order freedom of the construction follows naturally from this proposal, without having recourse to unmotivated syntactic movement. A new interpretive mechanism is proposed, under the name R(eferential)-index mechanism, to capture the semantic effects of the construction (such as the obligatory restrictive reading). I compare my syntactic analysis to LCA-based competitors and argue that my account is superior in a number of respects.

Turning to the interpretation of polydefinites, it is argued that the structure assigned to the construction reflects the empirical fact that polydefinites present weak markedness effects. I also discuss the interpretive properties of the R-index mechanism. This proposal allows a natural characterization of the distinction between internal and external modification. This dichotomy is then shown to be instrumental in capturing syntactic and interpretive constraints on determiner spreading.

Furthermore, I investigate what happens in Greek indefinites (*ena pseftiko chrisso roloi* ‘a fake golden watch’), which present the same word order variation as

polydefinites, but without indefinite determiner spreading. It is shown that analyzing Greek indefinites on a par with Romance indefinites (e.g. French, Spanish) is unwise, because of differences in ordering possibilities and the obligatory restrictiveness associated with Greek post-nominal adjectives. I suggest instead that Greek indefinites with post-nominal adjectives should be analyzed similarly to Greek polydefinites. Following a suggestion in the literature, I argue that the indefinite *ena* is in fact a quantifier and that the Greek indefinite determiner is phonologically null. On this view, Greek indefinites may exhibit hidden determiner spreading.

A tempting correlation that has been suggested in literature is between the Greek polydefinite and the Modern Persian Ezafe constructions. It is explained that these constructions cannot be analyzed similarly to each other due to major syntactic, semantic and configurational differences. They do not constitute therefore, the two sides of the same coin, since their nature is rather different.

TABLE OF CONTENTS

ACKNOWLEDGEMENTS	11
LIST OF ABBREVIATIONS	14
CHAPTER 1 Introduction	17
CHAPTER 2 The Syntax of Greek Polydefinites	20
2.1 Introduction	20
2.2 Greek polydefinites as instances of close apposition	24
2.2.1 Apposition: close and loose appositives	24
2.2.2 Close apposition and polydefinites	26
2.2.3 Polydefinites and structures of apposition	28
2.2.4 A base-generation analysis for Greek polydefinites	31
2.3 The interpretive mechanism of polydefinites	37
2.3.1 R-role identification	38
2.3.2 Strings of the form D A A D A N	40
2.3.3 An alternative proposal: The R-index identification mechanism	42
2.4 The LCA-based analysis	46
2.5 On DP-internal movement	63
2.5.1 DP-internal movement as a free option	63
2.5.2 Is there DP-internal movement?	68
2.6 Concluding remarks	74
2.6.1 Polydefinites with numerals	75
2.6.2 Conclusion	76

CHAPTER 3	The Interpretation of Polydefinites	78
3.1	Introduction	78
3.2	Modification in monadics and polydefinites	79
3.2.1	Modification in monadics	80
3.2.2	Modification in polydefinites	83
3.2.3	Comma intonation and scope	86
3.2.4	Further points	87
3.3	The interpretive properties of the R-index mechanism	94
3.3.1	Some basic notions in the semantics of adjectival modification	94
3.3.2	Expanding the notion of intersection	98
3.3.3	The properties of the interpretive mechanism of polydefinites	101
3.3.4	External modification and indirect modification	106
3.4	Concluding remarks	109
CHAPTER 4	The Syntactic Status of Greek Indefinites	111
4.1	Introduction	111
4.2	Indefinites in French and Spanish	115
4.3	Towards an analysis of Romance indefinite DPs	121
4.3.1	Bouchard's analysis	121
4.3.2	An alternative analysis	136
4.4	Back to Greek: Indefinite DPs	141
4.4.1	Indefinite determiner or quantifier?	144
4.4.2	Poly <i>in</i> definites	146
4.5	Concluding remarks	153

CHAPTER 5	Persian Ezafe and Greek Polydefinites	155
5.1	Introduction	155
5.2	The Ezafe construction: an overview of the basic facts and accounts	158
5.2.1	Samiiian (1994)	160
5.2.2	Ghomeshi (1997a, b)	164
5.2.3	Larson & Yamakido (2008)	168
5.2.4	A brief outline of Samvelian (2007)	173
5.2.5	Ezafe as a linker (Ruff, 2008)	177
5.3	Persian Ezafe and Greek polydefinites	179
5.3.1	Greek polydefinites in a DP-shell analysis	179
5.3.2	Can Persian Ezafe and Greek polydefinites be unified?	
	Empirical issues	182
5.3.3	Theoretical issues in Larson & Yamakido's (2008) account	192
5.4	Concluding remarks	195
CHAPTER 6	Conclusion	197
REFERENCES		200

ACKNOWLEDGEMENTS

During this four-year period, as a Ph.D. student, I was thinking that I would be extremely happy, the moment I would completed my thesis. This moment has definitely arrived and while I am writing these lines, I can confirm that this feeling is only partly verified. On the one hand, I am really satisfied that after a long and fruitful period of studying/doing research, in which I have met many experts in the area of Linguistics, I have written again and again the various parts of this thesis and I have learned so many new things, I finally arrived to the desirable result: a complete Ph.D. dissertation. On the other hand, the fact that these four of the most beautiful years in my life until now, in London, at UCL, have already passed, makes me feel somehow melancholic and nostalgic in a positive way though, because I only have good memories. So, I am pleased to express my gratitude to some really important people who contributed to this dissertation in various ways.

First and foremost, I am fully indebted to my supervisor, Hans van de Koot. For these four years Hans has always been helpful, encouraging, patient and passionate in the way he has worked with me. Our cooperation has been excellent. Hans worked systematically with me on many drafts of the chapters, he gave me numerous insightful comments, he made useful suggestions and we had interesting and inspiring discussions during my Ph.D. research. Hans actually taught me how to think syntactically and I immensely appreciate his various valuable inputs. It is an honour and luck to have had him as my supervisor. *Thank you so much Hans.*

I also would like to thank my second supervisor, Ad Neeleman. Ad was the very first person I met at UCL, before beginning my research. He introduced me to

the department of Linguistics and he helped me in my first steps towards my new life as a Ph.D. student. During my research, he has never failed to offer support, make comments and discuss with me various parts of my work.

My thanks also go to Luisa Marti, Nausicaa Pouscoulous and Reiko Vermeulen for various useful discussions I had with them. In addition, I wish to thank those who introduced me (along with my supervisors) to the life in the department of Linguistics when I first arrived at UCL: Richard Breheny, Robyn Carston, Annabel Cormack, John Harris, Neil Smith and Moira Yip. People at the Research Department of Linguistics at UCL have always been friendly and life has always been intellectually stimulating.

I also benefited from discussions and other information many people gave me: Klaus Abels, Artemis Alexiadou, Akis Kechagias, Dimitra Kolliakou, Marika Lekakou, Eric Mathieu, Matthew Reeve, Villy Rouchota, Anna Roussou, Joy Ruff, Kriszta Szendrői, Rob Truswell and Hiroyuki Uchida. Many thanks go to them too.

My research has been financially supported by Greek State's Scholarships Foundation (I.K.Y.). I am grateful to Prof. G. Babiniotis, who has systematically given his advice and his support to me on behalf of I.K.Y. I am also grateful to Dionysis Goutsos, my BA dissertation's supervisor, who has always offered his help to me till now.

My friends in the UK and Greece have enriched my life in various ways. They never failed to remind me that life has many beautiful aspects, besides linguistics. I owe much to them.

Finally, I would like to express my deepest gratitude to my family in Greece. My father Dimitris, my mother Kiki and my brother Stamatis always give me their unfailing and unconditional love, support and encouragement.

This book is dedicated to them.

London,
September 2010

LIST OF ABBREVIATIONS

ACC	accusative
AUX	auxiliary
DAT	dative
DEF	definite
DS	determiner spreading
EXT	extensional
EZ	ezafe
FUT	future
GEN	genitive
INDEF	indefinite
INT	intensional
MA	mood-aspect
NEUT	neuter
PAF	personal affix
PL	plural
POSS	possessive
PRT	particle
PST	past
REL	relative
RESTR	restrictive
SG	singular

*Δεν υπάρχουν ιδέες - υπάρχουν μονάχα άνθρωποι που
κουβαλούν τις ιδέες - κι αυτές παίρνουν το μπόι του ανθρώπου
που τις κουβαλάει¹.*

Νίκος Καζαντζάκης, «Αδερφοφάδες».

¹ There are no ideas – there are only men who carry ideas – and these ideas rise to the level of the man who carries them. Nikos Kazantzakis, “The Fratricides”.

CHAPTER 1

Introduction

This dissertation presents a study of the syntactic and interpretive properties of a Greek polydefinites. These are modified definites, containing repeated occurrences of the definite determiner. This phenomenon has attracted the attention of linguists from different allegiances and has been the subject of long-standing debate.

The main aim of this thesis is to motivate a particular analysis of polydefinites that not only accounts for their syntactic properties, but also captures the restrictions on the kind of adjectival modifiers with which they are compatible. It also attempts to shed light on the status of Greek indefinites, which share with polydefinites the property that adjectives may follow the head noun. My proposals are developed in the framework of generative grammar. More specifically, they assume the basic tenets of much current work within the Chomskyan tradition.

As a starting point of my discussion, in chapter 2, I am concerned with the distribution of the definite determiner within simple (monadic) and polydefinite DPs, giving rise to relatively free word order variation of the latter. More specifically, while post-nominal adjectives are impossible in monadics, they are freely allowed in polydefinites. In line with previous work by Lekakou & Szendrői (2007), I argue that polydefinites have the properties of structures of close apposition and should therefore be analyzed as such. I point out that the various internal alternations in the position of elements seem to be captured adequately putting forward an account without any recourse to movement. The aforementioned central assumption leads us to discuss the basics of the interpretation of polydefinites, that is the semantic composition of the DPs that make up an entire polydefinite. This results in proposing

a new interpretive mechanism which can capture the peculiarity of polydefinites with regard to their possible readings. Furthermore, I jettison the idea of an LCA-based analysis of this construction discussing a number of drawbacks for such an approach. I also demonstrate that permitting DP-internal movement in polydefinites as a free option is problematic and discuss in some detail how such movement can be ruled out in a principled way.

The syntactic analysis and the interpretive mechanism of polydefinites, introduced in chapter 2, constitute the basis for a further discussion of the interpretive relations in Greek polydefinites, which takes place in chapter 3. My primary aim here is to show that the interpretive differences between simple DPs and polydefinites are expected taking into account the proposal presented in chapter 2 additionally to some fairly standard assumptions about adjectival modification. Under this perspective, I distinguish the semantic hierarchy for adjectival modification (as outlined for English, by e.g. Bloomfield, 1933) and the grammar-external concept of ‘default search order’. I then present the consequences of that distinction on the interpretation of simple DPs and polydefinites. This discussion, will offer further evidence against accounts that propose a derivation of polydefinites through single extended nominal projections. I also revisit, in this chapter, the effects of the interpretive mechanism of polydefinites presented in chapter 2. This mechanism suggests that two distinct processes of modification, internally and externally, take place in polydefinites. This distinction is assumed to be responsible for the special interpretive effects that polydefinites yield.

Chapter 4 deals with the syntactic status of Greek indefinite DPs. The internal word order freedom, hence the existence of post-nominal adjectives, along

with the fact that there is no multiple occurrence of the – presumably – indefinite determiner seems puzzling at first sight. Thus, I first look at the syntax of languages like French, which permit post-nominal adjectives to determine whether there are aspects in common with their Greek counterparts. So, I consider the position of adjectives with respect to the noun in French, the relevant word order variation and their potential interpretive effects, along with a corresponding set of data from Spanish. After discussing potential accounts to capture the aforementioned facts, I return to Greek indefinites, arguing that a unified account of Greek and Romance indefinites is out of the question and that instead we should consider the possibility that Greek has polyindefinites. In the rest of this chapter I am occupied with this crucial question.

Chapter 5 investigates whether the Greek polydefinite construction can be analyzed on a par with the Persian Ezafe construction, an idea that has been proposed in literature. I present in detail the basic facts about Ezafe, discussing some major proposals regarding the status of this linking morpheme. I focus on Larson & Yamakido's (2008) account, which proposes a unified analysis of Ezafe construction and Greek polydefinites. I argue that their approach faces some serious empirical and theoretical shortcomings and I discuss extensively why a unified account of these two phenomena is bound to be unsuccessful.

Finally, chapter 6 offers a summary of this dissertation, underlining the main findings and conclusions.

CHAPTER 2

The Syntax of Greek Polydefinites

2.1 Introduction

The present chapter is concerned with an aspect of the internal structure of Greek DPs. In particular, it aims to provide an analysis of DPs which contain multiple realizations of the definite determiner, also known as polydefinites. So, the core issues that this chapter deals with are the distribution of the definite determiner, the syntactic structure assigned to these DPs and their interpretation. More specifically, I partially follow Lekakou & Szendrői's (2007) proposal, which treats polydefinites as instances of close apposition (I present this proposal in detail in section 2.2). In addition, I introduce a mechanism that captures the interpretive properties of polydefinites, which are further discussed, in their various aspects, in chapter 3.

Polydefinite structures constitute an interesting phenomenon in Greek. Their main characteristic is that the definite determiner is multiply realized within the same DP. As shown in (1), it is possible for the noun and each adjective to be accompanied by its own determiner. The phenomenon of *polydefiniteness* is often referred to in the literature with the term *determiner spreading* (DS)². This term was introduced by Androutsopoulou (1994, 1995)³.

² Although these two terms are more or less synonymous, we use them in a distinct way throughout this thesis: the term *determiner spreading* refers to the phenomenon of the multiple occurrence of the definite determiner within the DP, while the term *polydefinite* refers to the construction itself (the characteristic of which is determiner spreading).

³ *Determiner doubling, double definiteness, adjectival determiners, definiteness concord, definite adjectives* are some other terms found in literature.

(1)	a.	to	pseftiko ⁴	to	chrisso	to	roloi
		<i>the-</i>	<i>fake-</i>	<i>the-</i>	<i>golden-</i>	<i>the-</i>	<i>watch-</i>
		NEUT.SG	NEUT.SG	NEUT.SG	NEUT.SG	NEUT.SG	NEUT.SG
	b.	to	roloi	to	pseftiko	to	chrisso
		<i>the-</i>	<i>watch-</i>	<i>the-</i>	<i>fake-</i>	<i>the-</i>	<i>golden-</i>
		NEUT.SG	NEUT.SG	NEUT.SG	NEUT.SG	NEUT.SG	NEUT.SG

As shown by the examples in (2), the pre-adjectival determiner is optional for pre-nominal adjectives, but obligatory for post-nominal ones.

(2)	a.	to	pseftiko	chrisso	roloi
		<i>the</i>	<i>fake</i>	<i>golden</i>	<i>watch</i>
	b.	*	to	roloi	pseftiko
			<i>the</i>	<i>watch</i>	<i>fake</i>
				<i>golden</i>	

Examples like (2a), with only one definite determiner, are generally known as *monadics*, and are said to be reminiscent of English definites (Kolliakou 2004), where attributive adjectives are required to precede the noun (as in (3a), below) and a single definite determiner occurs in the left periphery of the DP. The basic scheme of such a structure is D A N, e.g.:

(3)	the	fake	watch
	<i>to</i>	<i>pseftiko</i>	<i>roloi</i>

⁴ A fuller discussion of why such an adjective (like ‘fake’) is well-formed in a polydefinite will follow in Chapter 3.

Thus, the word order in Greek and English monadic DPs is identical; the determiner precedes any adjectives and the adjectives precede the noun. It is only with polydefinites that we find adjectives surfacing after the noun.

As I said above, determiner spreading is optional pre-nominally. However, in case of partial determiner spreading (i.e. when some but not all definite determiners are present) ordering possibilities are restricted. As shown in (4), partial DS cannot skip an adjective.

- (4) a. to mikro chrisso roloi to pseftiko
 the small golden watch the fake
- b. * to mikro chrisso to pseftiko roloi
 the small golden the fake watch

As already mentioned, in the absence of determiner spreading the order of constituents in the Greek DP is rigid. By contrast, repetition of the definite determiner in front of every adjective makes available a great degree of order variation, as shown in (5). The reader may observe that both (5c) and (5f) bear the symbol (#), so as to indicate potential marginality. These phrases are in fact grammatical, but have a special interpretation. This fact needs to be reflected in the syntactic account. I return to this in later sections.

- (5) a. to pseftiko to chrisso to roloi
 the fake the golden the watch
- b. to pseftiko to roloi to chrisso
 the fake the watch the golden

- | | | | | | | | |
|----|-----|------------|---------------|------------|---------------|------------|---------------|
| c. | (#) | to | roloi | to | pseftiko | to | chrisso |
| | | <i>the</i> | <i>watch</i> | <i>the</i> | <i>fake</i> | <i>the</i> | <i>golden</i> |
| d. | | to | roloi | to | chrisso | to | pseftiko |
| | | <i>the</i> | <i>watch</i> | <i>the</i> | <i>golden</i> | <i>the</i> | <i>fake</i> |
| e. | | to | chrisso | to | roloi | to | pseftiko |
| | | <i>the</i> | <i>golden</i> | <i>the</i> | <i>watch</i> | <i>the</i> | <i>fake</i> |
| f. | (#) | to | chrisso | to | pseftiko | to | roloi |
| | | <i>the</i> | <i>golden</i> | <i>the</i> | <i>fake</i> | <i>the</i> | <i>watch</i> |

Two immediate questions arise at this point: a) what is the internal structure of polydefinites and b) what is the syntactic account that can capture adequately the possible orderings exemplified in (5), while also successfully representing the scope relations between the various elements inside each DP⁵?

This chapter is structured as follows: in section 2.2, I first introduce the analysis of polydefinite constructions in terms of close apposition proposed by Lekakou & Szendrői (2007), which I partially follow. I also demonstrate that the ordering facts can be accounted for assuming only base-generated structures. Then, in section 2.3, I discuss one aspect of the interpretation of polydefinites, namely the semantic composition of the DPs that make up a polydefinite, proposing a different mechanism from that advanced Lekakou & Szendrői's account. In section 2.4, I discuss the main alternative analysis in the literature, namely the LCA-based account put forward by Alexiadou & Wilder (1998) and point out some major problems with it. In section 2.5, I discuss the results from allowing DP-internal movement in polydefinites as a free option and suggest potential ways out of the undesirable

⁵ For the use of the term 'scope' throughout this thesis, see the following sections and more especially chapter 3.

situation that movement creates. Finally, in section 2.6, I close the chapter with a discussion of polydefinites containing numerals and some concluding remarks.

2.2 Greek polydefinites as instances of close apposition

Before discussing the structure of polydefinites, I will give a brief overview of those properties of apposition which are relevant to the discussion that follows.

2.2.1 Apposition: close and loose appositives⁶

There are two kinds of apposition described in literature: close and loose apposition, which are exemplified in (6):

- (6) a. Blair the politician... (close apposition)
b. Blair, the politician, ... (loose apposition)

A number of properties differentiate close from loose apposition and make them distinguishable⁷.

In close apposition nothing can intervene between the two parts. These parts are DPs which are strictly related. Only one phrasal stress can be assigned, as the two elements in apposition belong to and form a single intonational unit. Furthermore, the two parts refer to a unique entity, which is determined by both of them together.

⁶ There is a considerable debate in the literature on these two kinds of apposition (see among others, Burton-Roberts 1975, Espinal 1991, Stavrou 1995 for Greek, Acuña-Fariña 1999 and Keizer 2005). Moreover, a variety of terms is used in literature to refer to close vs. loose apposition, such as restrictive vs. non-restrictive apposition or integrated vs. supplementary apposition (see Potts 2005). In this thesis, I follow Lekakou and Szendrői in using the terms close and loose apposition.

⁷ We refer here to the differences between the two kinds of apposition that are (more or less) relevant to our topic.

In contrast, in structures of loose apposition, the first DP refers to a unique entity, while the second provides further/additional information about that entity. The two sub-parts do not form an intonational unit, as the second part is set off from the surrounding material by a pause preceding and following it. The two sub-parts carry their own stress and they can be separated by intervening expressions, as it is not necessary for them to be adjacent. Some researchers have suggested that instances of loose apposition are in fact parentheticals as far as their second sub-part is concerned (see e.g. Ackema & Neeleman 2004, Blakemore 2006, and Dehé & Kavalova 2007). The fact that the second element simply provides additional information to the first one leads to the idea that it is a predicate, whereas each part of a close appositive is referential, as Kolliakou (2004) and Lekakou & Szendrői (2007) note. So, in close apposition both parts refer to the same entity, so that both parts contribute directly to reference. Hence, the determination of reference is due to the joint contribution of the two appositive elements. Consider, e.g. the following sentences, which are examples adapted from Kolliakou (2004) and Lekakou & Szendrői (2007), respectively:

Tonight I will speak of a great French artist.

- (7) a. Guillem, the dancer, ... (loose apposition)
b. *Guillem the dancer ...

Tonight I will speak of the Van Gogh brothers, the painter and the critic.

- (8) a. Van Gogh the painter ... (close apposition)
b. *Van Gogh, the painter, ...

In (7), a reading in terms of loose apposition is more felicitous, as *Guillem* refers to a unique French artist by that name, and so the second part just adds some further information. In (8), both elements contribute to the determination of reference so that a reading in terms of close apposition is not only felicitous but required. Loose apposition is inappropriate here, because the so-called uniqueness presupposition with the first part is not satisfied.

Interestingly, as Lekakou & Szendrői (2007) note, close apposition necessarily involves a relationship between two DPs. On the other hand, any two categories (of the same type) can be combined under loose apposition, see e.g. (9):

- (9) a. He [_v ate], or rather [_v devoured], the whole pie.
(Adapted from Stavrou 1995)
b. * He [_v ate] [_v devoured] the whole pie.
c. [_{IP} John was speechless], I mean, [_{IP} he was really surprised].
d. * [_{IP} John was speechless] [_{IP} he was really surprised].
(Adapted from Lekakou & Szendrői 2007)

2.2.2 Close apposition and polydefinites

As we have already seen in the introduction, there is a multiple occurrence of the definite determiner in the polydefinite construction in Greek. Notably, this fact also holds for instances of close apposition in Greek. Consider e.g. the following examples in (10):

- (10) a. o elephandas to zoo
the elephant the Animal

- b. o Yanis o daskalos
 the John the teacher

Both constructions are made up necessarily from nominal elements. Both close appositives and DPs showing DS form a single integrated intonational unit. The subparts from which a close appositive or a polydefinite is constructed are independently referential, as they jointly contribute to the determination of reference and yield a restrictive reading. As we are going to see in the next sections this is a core property shared by these two syntactic structures. Moreover, the DPs that form part of the constructions under discussion can intuitively be well-formed on their own, as neither of them seems to be the head of the construction. In addition, both appositives (see (11a)) and polydefinites (see (11b)) can occur in a split construction with the initial DP receiving focus, (see Ntelitheos, 2004, for a related discussion. We may assume that the split construction arises as a result of focus movement.):

- (11) a. ton YANI fonaksa ton daskalo
 the John call-1SG.PST the teacher
 ‘‘It is the teacher John that I called’’
- b. to KITRINO agorasa to aftokinito
 the yellow buy-1SG.PST the car
 ‘‘It is the yellow car that I bought’’

These data confirm that there can be drawn a strong parallel between polydefinites and close appositives.

Taking into account these facts, which constitute common properties for close appositives and polydefinites, let us put forward our proposal.

2.2.3 Polydefinites and structures of apposition

Following Lekakou & Szendrői (2007), I will assume that the syntax of close appositives is argumentative, rather than predicative, as both DPs of the construction are referential DPs, as shown above. Furthermore, again in line with these authors, close appositives will be associated with a structure of mutual adjunction, as depicted in the following tree, where the subscripts merely serve to clarify the proposal and should not be interpreted as substantive properties:



The basis of the analysis that follows is the structure in (12). This is a multi-headed structure, in which both DP_1 and DP_2 project to form $DP_{1,2}$. The existence of such structures is expected if (i) syntactic trees obey Inclusiveness (see Chomsky 1995) and (ii) a node cannot contain the same property twice (see Neeleman & Van de Koot 2002, for extensive discussion). Thus, the properties of both DP_1 and DP_2 may be copied up to $DP_{1,2}$ under projection, as long as this does not result in a node with conflicting features.

On this analysis, the example (10b) will be assigned the following structure:

(13)

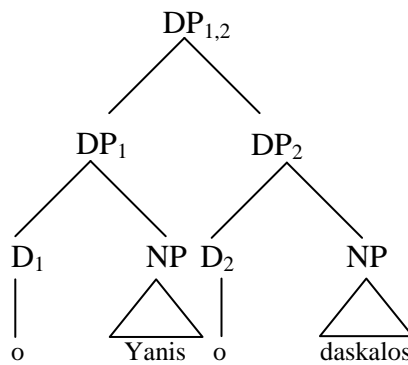

As shown in (13), neither of the DPs that make up the appositive is the unique head of the structure. Rather, the highest DP is a projection of both the lower DPs.

Lekakou & Szendrői (2007) argue extensively that polydefinites should be analyzed as close appositives. On this view, what distinguishes the former from the latter is that polydefinites involve an elided noun in one of the DP-parts⁸: [DP [DP to pseftiko Ø] [DP to roloi]] ‘the fake the watch’, [DP [DP to roloi] [DP to pseftiko Ø]] ‘the watch the fake’. Thus, the structure assigned to polydefinites is as in (14), where the two DPs form a larger DP that may act as an argument of a clausal predicate:

(14)

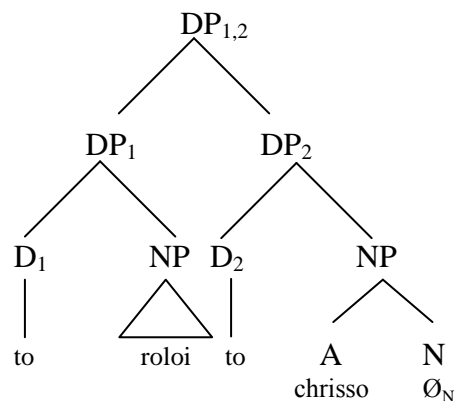

⁸ See also Panagiotidis (2005).

Lekakou & Szendrői (2007) say that the fact that the two DPs share inflectional properties and a selecting preposition (see (15) below) is also a piece of evidence that the two DPs form a larger DP constituent.

- (15) a. [DP [DP tu pseftikou [DP tu roloyiou]]]
 the.GEN fake.GEN the.GEN watch.GEN
- b. [PP P s- [DP [DP to pseftiko] [DP to roloi]]]
 to- the.ACC fake.ACC the.ACC watch.ACC
- c. *[PP P s- [DP [DP to pseftiko] [PP P s- [DP to roloi]]]
 to- the.ACC fake.ACC to-the.ACC watch.ACC

That the features carried by the sub-parts of a polydefinite should be identical follows from Inclusiveness. For example, if one sub-part is genitive, singular and neuter, then the second sub-part cannot contain conflicting features or a feature clash will result when these sub-parts simultaneously project. Because the properties of the sub-parts are represented on the top DP-node, that node contains properties that can be selected by a preposition that could also combine with each sub-part in a monadic structure.

A key advantage of this proposal, also evident from (14), is that it does not require assumptions about structure beyond what is required for monadics. Thus, the DPs involved in a polydefinite like e.g. [*to pseftiko* \emptyset_N] ‘the fake’ [*to roloi*] ‘the watch’ are themselves monadics as depicted in (16a) and (16b) respectively:

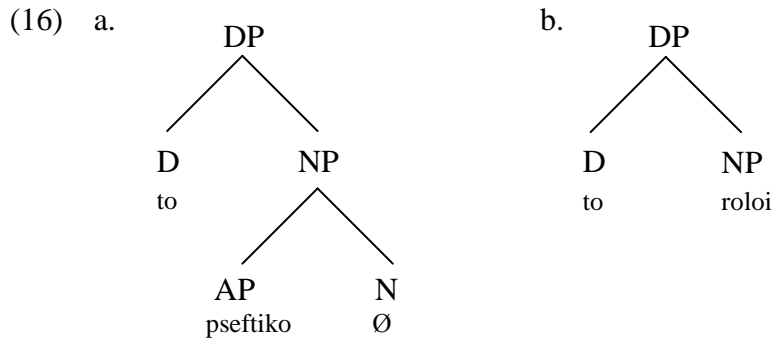

The basic structure proposed in (12) and exemplified in (14), has the welcome consequence that it can capture all the different orderings of a polydefinite structure, as will be demonstrated below.

2.2.4 A base-generation analysis for Greek polydefinites

As already mentioned, phrases (5c) and (5f) appear potentially marginal. To be more precise, when the adjective *chrisso* ‘golden’ takes ‘scope’ over the rest of the phrase, the interpretation of the latter deviates from the neutral meaning (on which *pseftiko* has ‘scope’ over *chrisso*). The background to this claim will be presented in chapter 3, where I will further clarify the relevant terminology in the context of a full discussion of adjectival modification in monadics and polydefinites. For now, let me just distinguish two sources of reading, the neutral and the marked⁹ one, which are briefly presented below:

- (17) a. [to pseftiko [to chrisso to roloi]]
 b. [to pseftiko [to roloi to chrisso]]
 (#) b'. [[to pseftiko to roloi] to chrisso]
 (#) c. [[to roloi to pseftiko] to chrisso]

⁹ I use the term marked only to differentiate the available interpretation from the neutral one. Again, this term is going to be explained in chapter 3.

- d. [[to roloi to chrisso] to pseftiko]
- e. [[to chrisso to roloi] to pseftiko]]
- (#) e'. [to chrisso [to roloi to pseftiko]]
- (#) f. [to chrisso [to pseftiko to roloi]]

Taking into account the above preliminaries on the interpretation of polydefinites, let me present in detail the structure of the phrases in (17). Thus, the only available interpretation of the string *to pseftiko to chrisso to roloi* ‘the fake the golden the watch’ is the following: from a set of watches, the speaker/hearer selects the golden ones and from the resulting set, the speaker/hearer picks out the subset whose members are fake (and not e.g. real). A base-generated structure that reflects this interpretation is depicted in (18):

(18) *Neutral source*

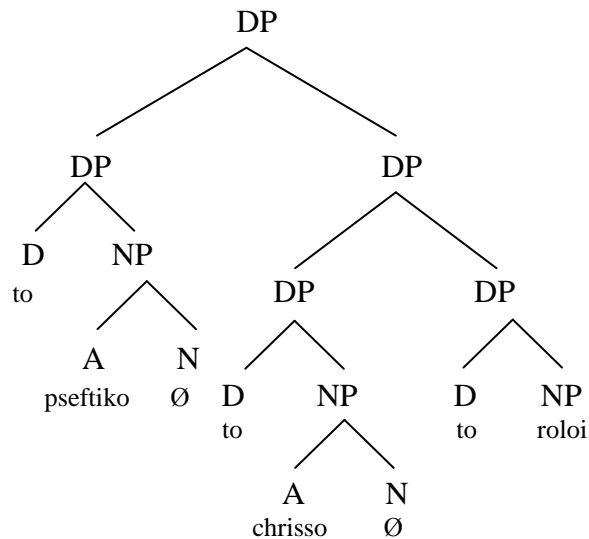

On the other hand, the phrase *to chrisso to pseftiko to roloi* ‘the golden the fake the watch’ has a marked interpretation, since it specifies a subset of the set of fake watches, namely, the subset whose members are golden. According to Alexiadou &

Wilder (1998), this marked sequence can be used if there is some extra interpretative need which is not satisfied by its neutral counterpart (e.g. a pre-established context).

The relevant structure is shown in (19):

(19) *Marked source*

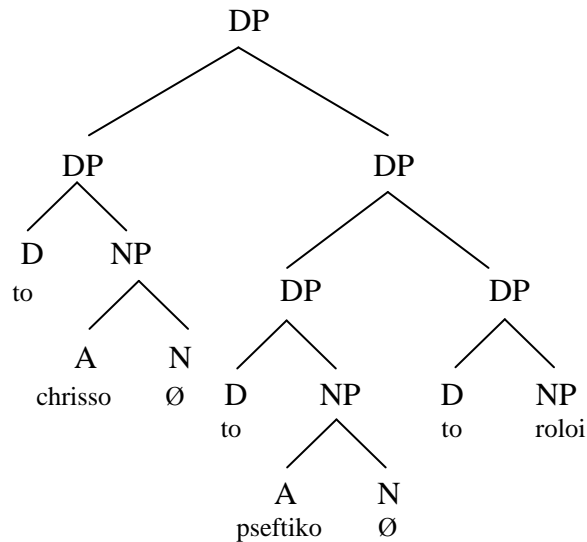

Let us now consider the phrase *to pseftiko to roloi to chrisso* ‘the fake the watch the golden’, which is ambiguous between an unmarked and a marked reading. It can be interpreted as “a golden watch which is fake” (neutral) and “a fake watch which is golden” (marked). A base-generated structure with the former interpretation is given in (20), while a base-generated structure with the latter reading appears in (21):

(20) *Neutral source*

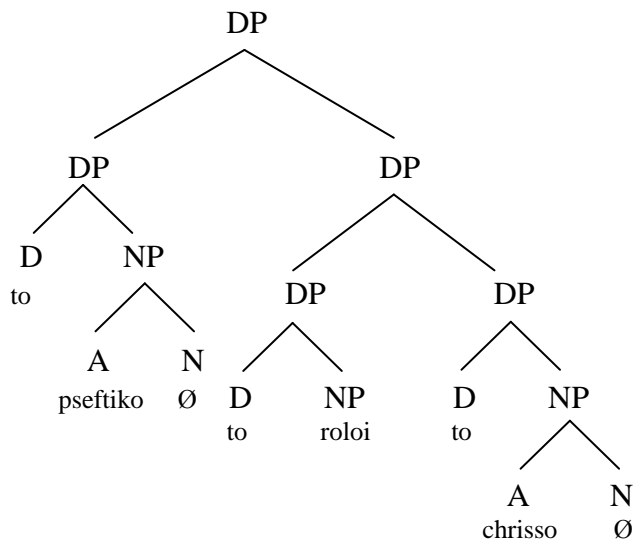

(21) *Marked source*

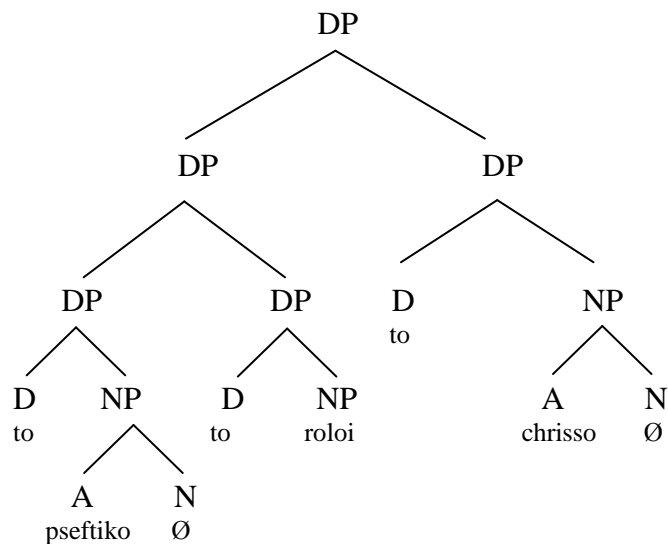

The phrase *to roloi to pseftiko to chrisso* ‘the watch the fake the golden’ is only associated with a marked reading; it refers to a fake watch which is golden. The relevant base-generated structure is shown below:

(22) *Marked source*

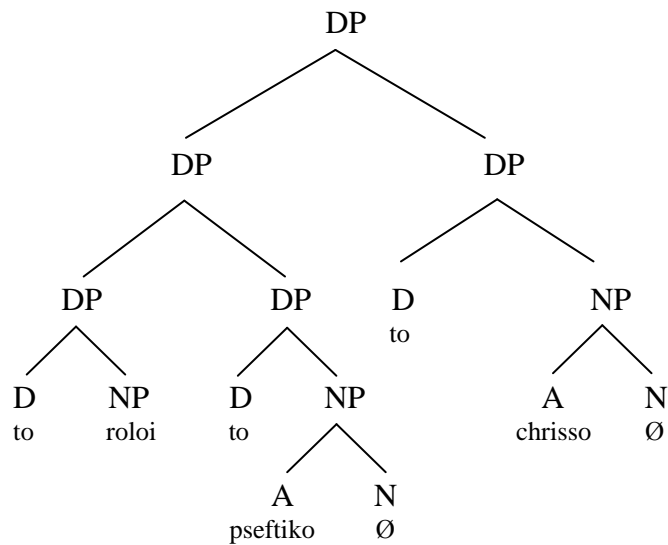

By contrast, the phrase *to roloi to chrisso to pseftiko* ‘the watch the golden the fake’ is only associated with an unmarked reading; it refers to a golden watch which is fake. The relevant structure is given below:

(23) *Neutral source*

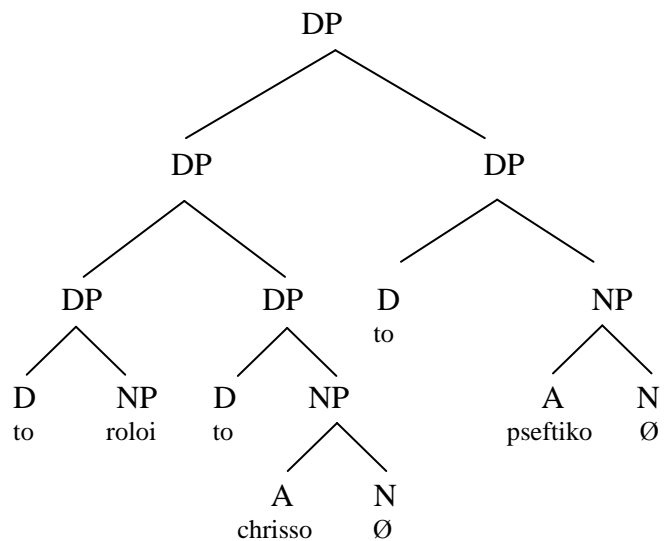

Finally, the string *to chrisso to roloi to pseftiko* ‘the golden the watch the fake’ is ambiguous, just like *to pseftiko to roloi to chrisso*. It has two possible interpretations

with respect to “scope” (pseftiko > chrisso (unmarked/neutral, and chrisso > pseftiko (marked)). The base-generated structures that express these readings are depicted below:

(24) *Neutral source*

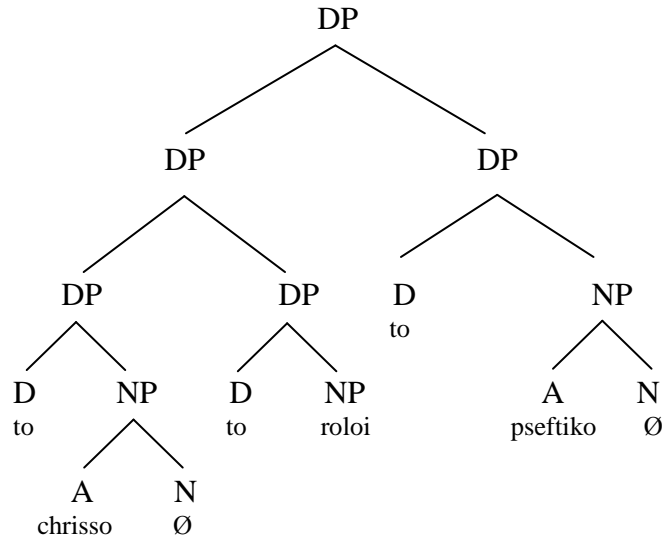

(25) *Marked source*

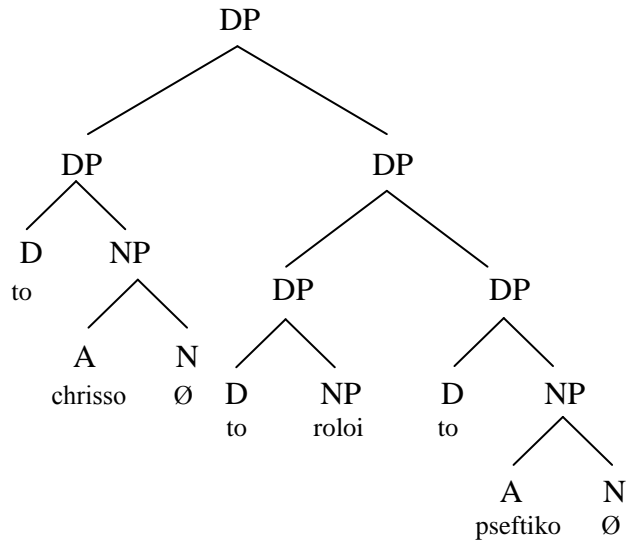

We conclude that a base-generation analysis of polydefinites is possible. Importantly, such an analysis makes available all possible readings of a polydefinite, under all its permutations.

Clearly, this analysis will face complications if movement is introduced as an option to capture the different serializations of a polydefinite. These complications will be of two kinds. On the one hand, it will introduce redundancy, with the same combination of surface order and interpretation derivable through base-generation only and through a combination of base-generation and movement. On the other hand, movement will allow certain surface orders to be associated with readings that native speakers say are unavailable.

I return to this issue in section 2.5, where I look at these complications and address the question whether there is a principled way to avoid them.

2.3 The interpretive mechanism of polydefinites

In §2.2.2, we remarked that each of the nominals which constitute/are sub-parts of a close appositive or a polydefinite construction are referential. This crucially holds for both close appositives and polydefinites. Moreover, as already noted a bare adjective cannot intervene either in the polydefinite or the close appositive constructions. In this section, I consider the compositional mechanism responsible for the semantic interpretation of these structures and show how it captures their properties.

2.3.1 R-role identification

Williams (1984, 1989) and Higginbotham (1985), among others, assume that nouns have an R(eferential)-role, additionally to other θ -roles they discharge. The R-role is their external θ -role. According to Higginbotham, the R-role is satisfied by the determiner, whereas Williams assumes that the R-role can be assigned reference and as such, is not satisfied by a syntactic element. Another assumption of Williams is that the R-role survives until the top node of the nominal projection. The presence of this role on the maximal projection of a nominal allows it to function as an argument, because it gets ‘bound’ there by one of the θ -roles of the verb (this is Williams’s implementation of θ -role assignment).

Higginbotham (1985) proposes that the external θ -role of a modifying adjective and the R-role of the noun are coindexed and in this way are related. This is what Higginbotham names theta-identification. On his view, NPs are predicates whose external θ -role is bound by a determiner, if the DP is used as an argument. Theta-identification ensures that whatever satisfies the R-role of the noun satisfies the θ -role of the adjective as well. Thus, a nominal expression like *to chrisso roloi* refers to an entity that is both golden and a watch.

Concerning the interpretation of close appositives/polydefinites, Lekakou & Szendrői (2007) follow Williams’s implementation, according to which the R-role of the noun is not satisfied by the determiner but is assigned reference on the top node of a nominal expression. On this view, the R-roles of DPs that form part of an appositive or polydefinite survive to the top node of the construction, where they are identified and assigned reference. They see the Higginbotham variant, which has R-roles satisfied by determiners, as problematic, because it appears to make no

semantic mechanism available by which the constituents that make up an appositive or polydefinite could be combined.

Consequently, the proposal is that in close apposition/polydefinites, the R-roles of the constituent DP are identified by an operation which results in complex argument formation, as illustrated in (26) below:

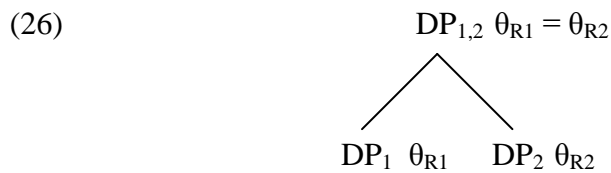

Adapted from Lekakou & Szendrői (2007)

Thus, on this analysis, the structure of a polydefinite is as shown in (27), where – as before – the subscripts are merely used for ease of presentation.

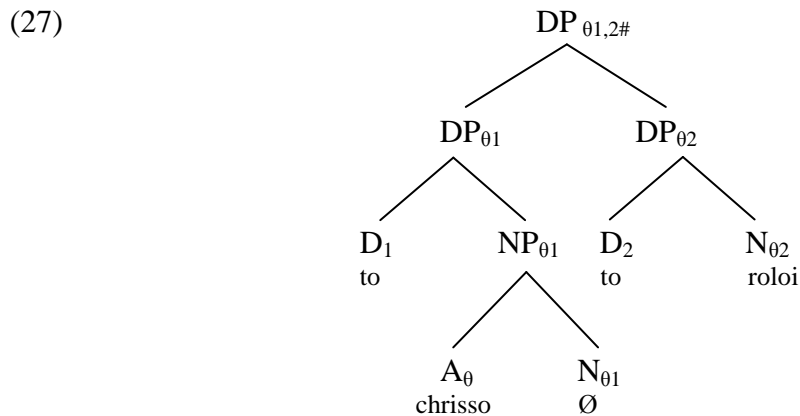

As already noted in section 2.2.3, multi-headed structures involving identification of theta roles, as illustrated in (26) and (27), are expected to exist on quite minimal assumptions about phrase structure, as discussed in some detail in Neeleman & Van

de Koot (2002). In particular, Inclusiveness allows a mother node to inherit the categorial features of one or more of its daughters (projection). Multiple inheritance is of course constrained by feature co-occurrence restrictions on the receiving node, so that categorial projection usually involves inheritance from one daughter only. If it is furthermore assumed that a node cannot contain the same feature twice unless a partial order is inherited under copying within a projection (as in the case of θ -grids), then copying the same feature from both daughters will result in identification of those features on the mother. This is so because these features cannot be distinguished on the mother in the absence of ordering, and introducing ad hoc order would violate Inclusiveness.

Adopting these assumptions, the thematic roles in (26) can be copied up under projection to the top-most DP-layer. Since they cannot be ordered on the receiving node without violating Inclusiveness, the two roles ‘collapse’; that is to say, they get identified. This implementation is arguably an improvement over Higginbotham’s theta-identification in that there is no need for a separate rule of co-indexation.

2.3.2 Strings of the form D A A D A N

Lekakou & Szendrői (2007) follow Williams (1980) and Higginbotham (1985) in assuming that nominal elements come with an external theta-role, the so-called R-role, which ensures that the nominal has the capacity to act as a referential expression. Furthermore, following Williams (1989) these R-roles are not automatically saturated by definite determiners. Rather, the R-role survives until the

top-most DP-layer of the nominal projection, where it either gets bound by one of the theta-roles of the verb, or ensures that the DP may act as a predicate.

Lekakou and Szendrői refer to the operation illustrated in (26) as ‘complex argument formation’. However, this seems somewhat of a misnomer, as the DPs that are combined in this structure are predicates. As I will now argue, this aspect of the analysis makes it impossible to capture the ungrammaticality of strings of the form D A A D A N, like *to mikro chrisso to pseftiko roloi* ‘the small golden the fake watch’.

Examples of this type are not excluded because Williams’s interpretive mechanism fails to ensure the insertion of a definite determiner before a bare adjective in a polydefinite construction. This is a direct consequence of the fact that the combinatory operation in (26) applies to predicates.

Consider the structure in (28), where the R-role of the DP *to pseftiko roloi* ‘the fake watch’ remains unsaturated. Hence, it can be identified with the θ -role of the adjective *chrisso* ‘golden’. The resulting R-role is then copied up to the top-most DP, where it is identified with the unsaturated R-role of *to mikro* \emptyset_N ‘the small’. The resulting DP is interpreted as an argument once the top R-role is bound to the θ -role of a higher predicate. Thus, the structure in (28) is incorrectly ruled in.

(28)

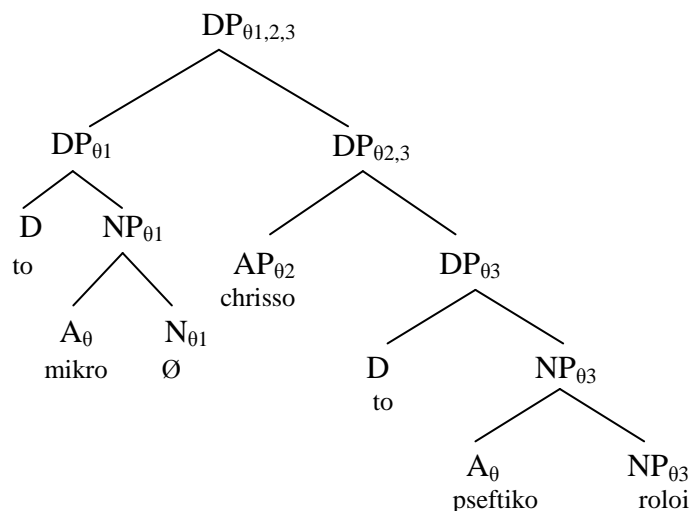

It is easy to see that this problem arises as a result of the fact that the compositional mechanism that forms polydefinites operates on predicates.

2.3.3 An alternative proposal: The R-index identification mechanism

Lekakou & Szendrői (2007) proposal amounts to using Williams' and Higginbotham's interpretive mechanism for adjectival modification in monadics for the interpretation of polydefinites. I think that such an approach does not capture adequately the special nature of DPs in DS, namely the fact that these phrases are independently referential. My claim is that the interpretive mechanism operative in polydefinites is different from that regulating adjectival modification in monadics, although the technical implementation remains entirely parallel.

First, let us assume that the R-role in each sub-part of a polydefinite is satisfied internally to that sub-part. If so, the DPs in DS will each carry a *referential index*, which might be called an *R-index*, and no theta-role. Of course, these indices are not substantive properties, but they are used for expository purposes. In fact, each DP in a structure of DS carries a satisfied theta-role, marked by Neeleman & Van de

Koot (2002) as a theta with a hash (#), as a subscript ($\theta_{\#}$). This hash (the equivalent of a referential index) can be considered recoverable, as it can be locally determined that the theta-role is satisfied. When these satisfied theta-roles are copied up, they collapse, just like two unsatisfied theta-roles would.

Let us assume, then, that an R-index may be copied up. Moreover, no argument may carry two distinct R-indices (if an R-index is represented as $\theta_{\#}$, the R-indices will in fact never *be* distinct). These assumptions suffice to permit structures as in (29), where two arguments percolate their referential index in a structure of mutual adjunction. The two DPs must percolate identical indices, or the resulting complex argument will carry more than one referential index.

(29)

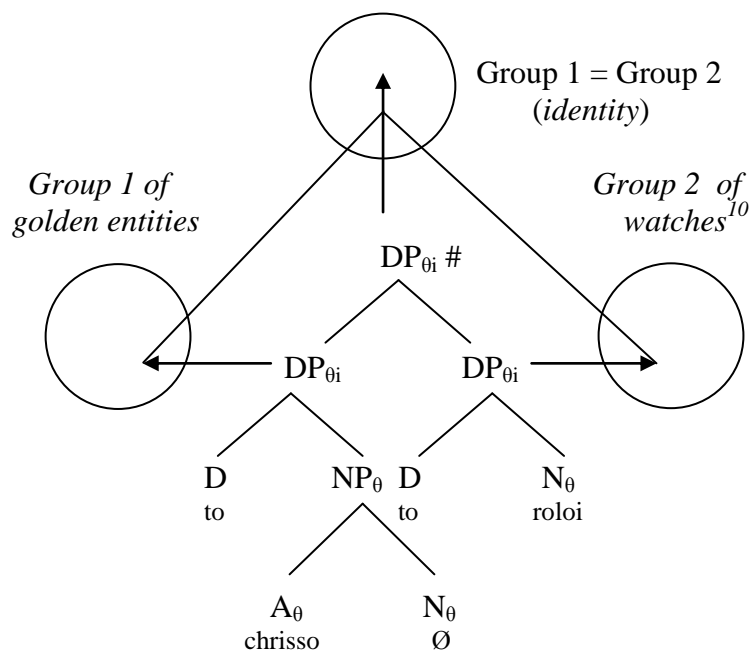

¹⁰ This definite DP picks out a single watch from a group of watches. Of course it could select more than one watch if the whole phrase was in plural, since polydefinites do have a plural form as any nominal in Greek.

Here we have the phrase *to chrisso to roloi* ‘the golden the watch’. We may remain agnostic about what makes the DP *to chrisso* referential, but it could be that the definite determiner saturates the external θ -role of the NP containing *chrisso* making it referential. Hence, this DP carries a referential index (*i*) that can be identified with that of the DP *to roloi*. We can think of this identification as a process that forces the reference of *to chrisso* \emptyset_N to be identical with that of *to roloi*, thereby yielding what I will call ‘coerced identity’. Now, it seems reasonable to assume that a reference assignment is not a fully automatic process. That is to say, if we mention *to roloi* ‘the watch’ in a context in which there are several watches, then the reference of this DP is potentially indeterminate. By coercing identity between *to roloi* and *to chrisso* \emptyset_N , we narrow down the possibilities of reference assignment for *to roloi*. This is an effect akin to intersection, but is due to coerced referential identity. It is this imposition of identity, I claim, that is compatible with the restrictive reading associated with polydefinites. This aspect of the proposal will be supported by the analysis of adjectival modification to be presented in chapter 3.

This analysis is based on the claim that Higginbotham’s theta-identification (internal modification) should be distinguished from the identification of R-indices (external modification). On this view, both of these processes can be more clearly seen at work in DPs with partial DS, such as *to chrisso roloi to pseftiko* ‘the golden watch the fake’.

(30)

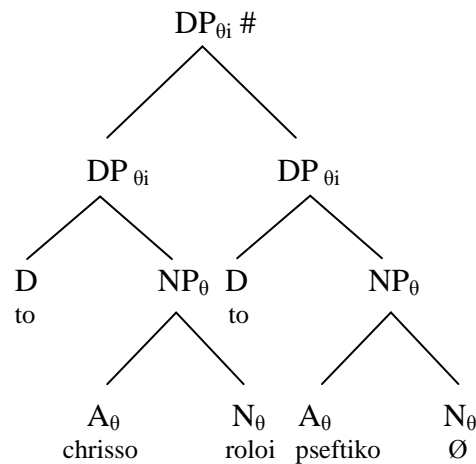

In the structure in (30), internal modification applies internally to *to chrisso roloi*, where the external θ -roles of *chrisso* and *roloi* undergo identification in the NP node directly dominating these heads, whereas external modification applies externally to the DPs *to chrisso roloi* and *to pseftiko*, through identification of the referential indices of these DPs in the DP-node formed through mutual adjunction.

The unavailability of strings with the pattern D A A D A N falls out naturally from the fact that internal modification can apply prior to external modification, but not vice versa. That is to say, there is no interpretive rule – other than θ -assignment – that can combine a constituent carrying a saturated θ -role (a referential index) with a constituent carrying an unsaturated θ -role. In particular, there is no rule that would allow such a structure to be interpreted as involving modification. Note also that there is independent evidence that a definite DP with an elided noun cannot contain more than one adjective¹¹. Therefore, a structure like that in (29) cannot give rise to the string D A A D A N through recursive adjectival modification in the DP with the elided noun. As a result, two distinct orders need to be excluded from the

¹¹ See chapter 4 for further discussion on this issue.

construction. First, an adjective cannot attach to a fully fledged DP and second, *D A A Ø is independently unavailable in Greek.

Our analysis has of course come at the cost of introducing a new rule of semantic composition. I believe that this rule is in fact independently motivated for structures of close apposition. In particular, in expressions like *Van Gogh the painter* that combine a name with a definite DP it would be very hard to maintain that a name is semantically a predicate prior to formation of the close appositive. Crucially, names cannot be used as a predicate, unless combined with a determiner. Thus, of the examples in (31) only in (31b) Stalin has predicative properties (it is asserted of John that he has Stalin-like properties), whereas (31a) is a quasi-equative with the interpretation ‘John plays the role of Stalin’).

- (31) a. John is Stalin.
 b. John is a Stalin.

2.4 The LCA-based analysis

Alexiadou & Wilder (1998) put forward an LCA-based analysis of the Greek polydefinite construction. Before discussing some main drawbacks of this proposal, I will give an outline of its basic points here. Alexiadou & Wilder adopt Kayne’s analysis for relative clauses, having argued for the validity of the following generalization in Greek:

- (32) *An adjective permits DS only if it can be used predicatively.*

“This (i.e. (32)) provides a major argument that modification displaying DS... is to be implemented in terms of underlying relative clauses, in which AP is predicated of a DP...” (Alexiadou & Wilder 1998: 314). Thus, Alexiadou and Wilder follow Kayne’s (1994) proposal that AP-modifiers should be analyzed as derived from an underlying relative clause structure, as exemplified in (33) (Kayne 1994, chapter 8, example (72)):

(33) $[_{DP} D \textit{ the } [_{CP} [_{AP} \textit{ yellow}]_j [_{C}^0 [_{IP} [\textit{ book}] [_{I}^0 t_j]]]]]$

(33) shows that the pronominal modifier of *book* originates as the adjectival predicate of the relative clause. It ends up preceding the NP following obligatory raising to the specifier of that relative clause.

Alexiadou & Wilder’s analysis of polydefinites is completely modeled on this analysis, with the single difference that spec,IP is not occupied by an NP but by a DP. Thus, the example *to pseftiko to chrisso to roloi* ‘the fake the golden the watch’, with the interpretation shown in (18), has the derived structure below:

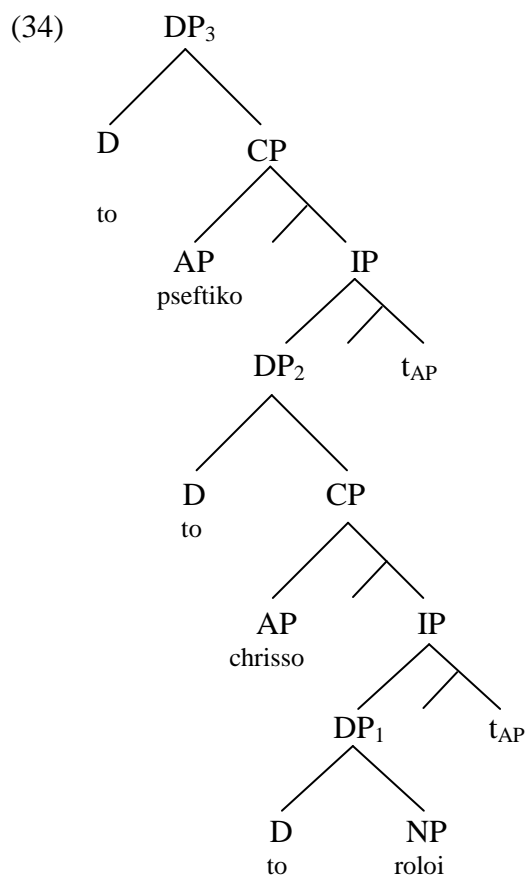

On this analysis, the different serialization possibilities are obtained by movement of subordinate DPs to superordinate Spec,DP positions. For example, the phrase *to pseftiko to roloi to chrisso* ‘the fake the watch the golden’, which has a neutral interpretation, has the following structure:

(35)

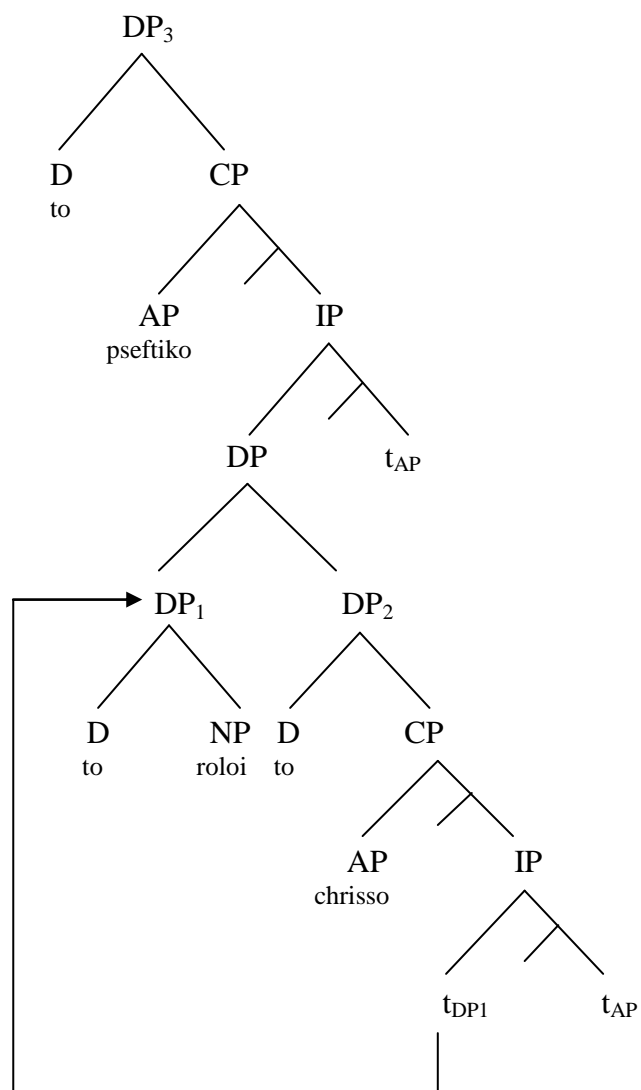

The structure of the phrase *to roloi to chrisso to pseftiko* ‘the watch the golden the fake’, with the neutral reading is depicted in (36); the derivation involves two movement operations:

(36)

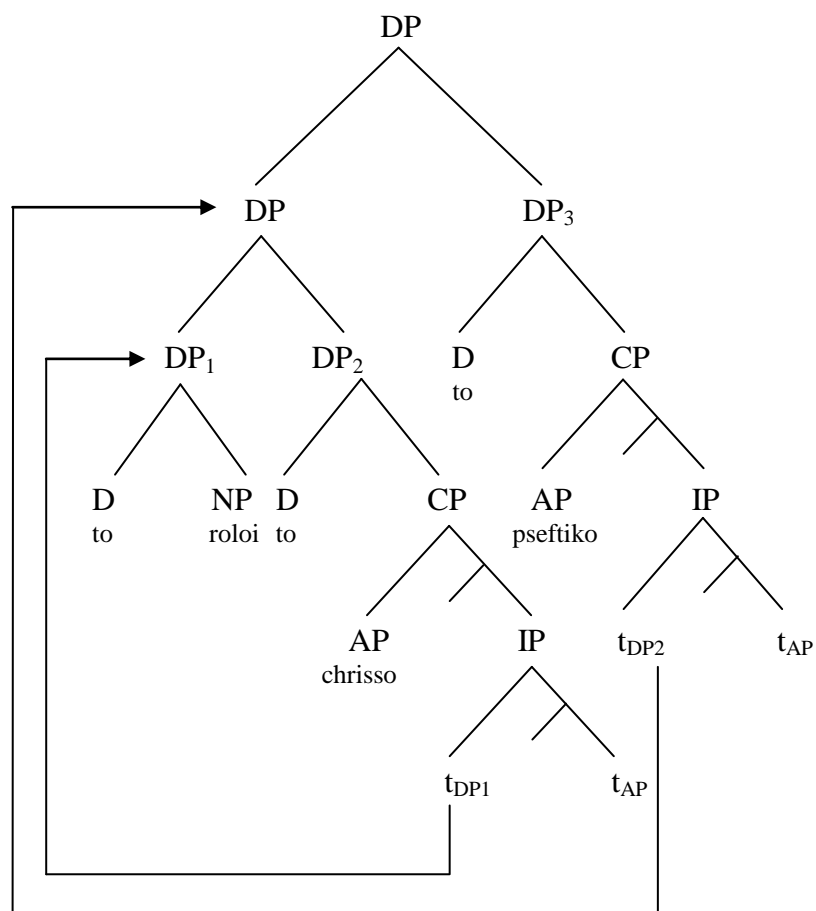

In the same vein, the structure illustrated in (37) is assigned to the phrase *to chrisso to roloi to pseftiko* ‘the golden the watch the fake’, which has again a neutral reading:

(37)

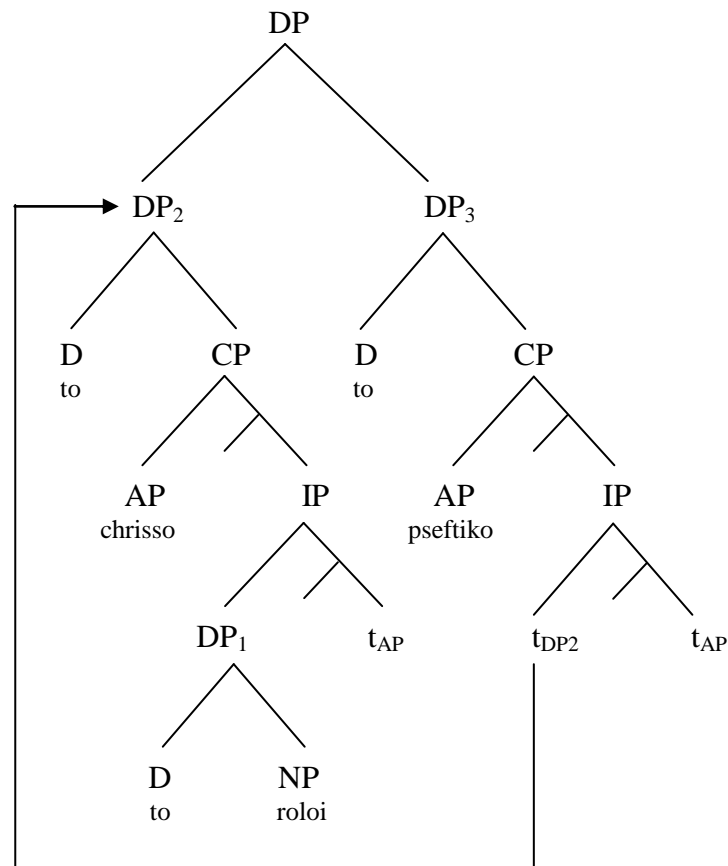

As already mentioned, the derivations depicted in the above trees (34 - 37) refer to unmarked sequences.

Before explaining what happens with the marked phrases, let me clarify that Alexiadou & Wilder (1998) consider only (17f) marked. Indeed, their account predicts the marked status of this example, as it cannot be derived from the neutral base-generated structure in (34). However, as the authors note, this phrase can correspond to an alternative base-generated hierarchy, in which the predicate *chrisso* ‘golden’ is predicated of the complex DP *to pseftiko to roloi* ‘the fake the book’. AP-fronting alone yields the relevant serialization, the structure of which is shown in (38):

(38)

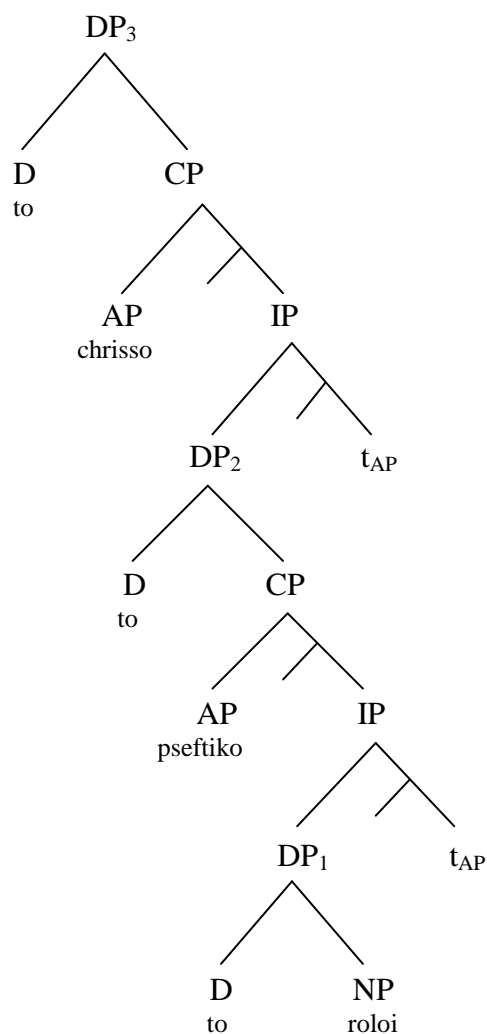

Let me now return to the marked structures (17b') and (17e'). Although Alexiadou & Wilder do not explicitly say that they can have a marked reading, their account can derive these structures, as shown in (39) and (40) respectively:

(39)

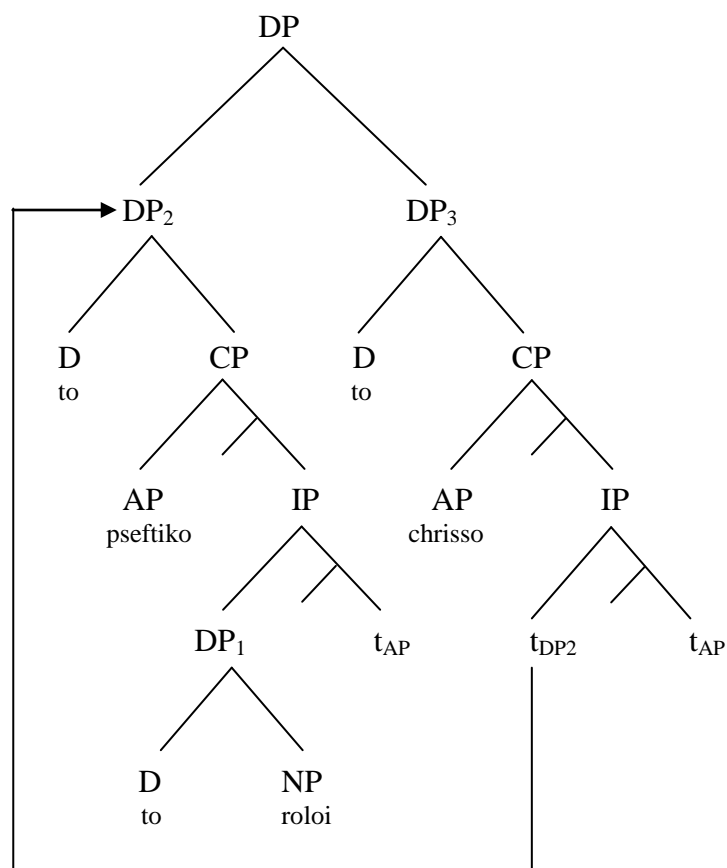

The above structure, which corresponds to (17b'), can be derived from the marked base-generated structure by a movement operation.

In the same vein, the structure in (40) corresponds to (17e') and is again derived from the marked base-generated structure.

(40)

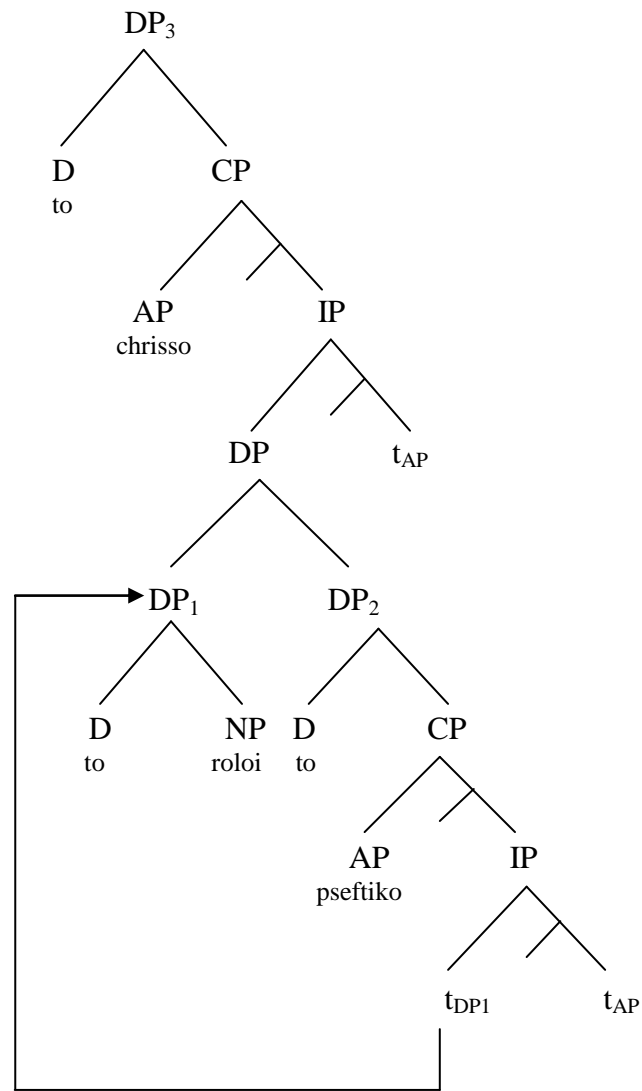

Let me now consider the phrase *to roloi to pseftiko to chrisso* ‘the watch the fake the golden’. This phrase has the marked interpretation in (17c). Again, Alexiadou & Wilder (1998) do not explicitly say that this string has a marked reading, but it can be derived from the marked base-generated structure, as shown in (41):

(41)

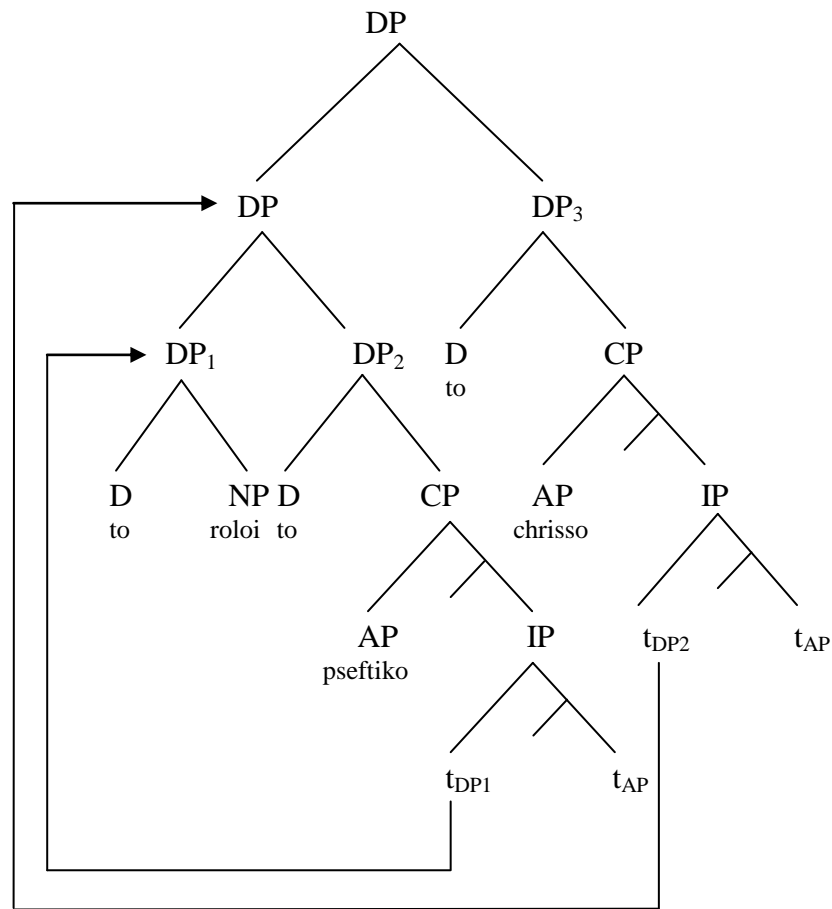

We have seen, up to this point, that all the data presented in (17) can be derived in the LCA-based account adopted by Alexiadou & Wilder.

However, as shown by Kolliakou (2004), Alexiadou & Wilder’s account faces the problem of overgeneration. In other words, Alexiadou & Wilder’s analysis yields a substantial amount of undesirable ambiguity, predicting that four orderings may be associated with either an unmarked or a marked interpretation. But, as shown in (17), only two orderings are ambiguous (compare (17b) – (17b’) and (17e) – (17e’)).

Let me show how their account overgenerates. The problem is found in phrases (17c) and (17d). Consider them one by one:

The phrase *to roloi to pseftiko to chrisso* ‘the watch the fake the golden’ should only be derivable from a marked source. But, in Alexiadou and Wilder’s account, it can also be derived from the unmarked source, as shown in (42):

(42)

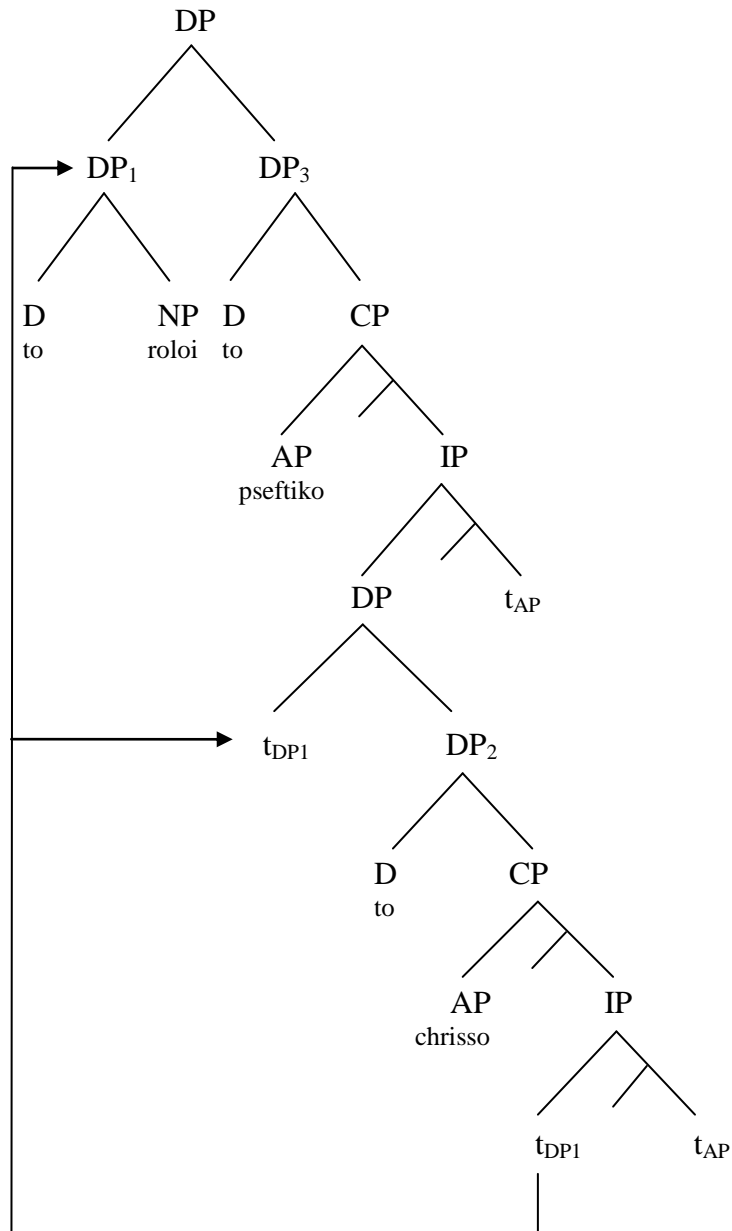

As Alexiadou & Wilder (1998) note, locality permits DP_j to be extracted out of the immediately dominating DP_k only via the Spec,DP_k. This gives rise to the

successive-cyclic movement observed in (42). But this derivation should not exist, since native speakers judge the unmarked reading unavailable for this string.

The phrase *to roloi to chrisso to pseftiko* ‘the watch the golden the fake’, which corresponds to the interpretation in (17d), has a neutral/unmarked reading. The structure of this string is shown in (36). But, on Alexiadou & Wilder’s assumptions the same phrase can be derived from the marked source as well. This is illustrated in (43):

(43)

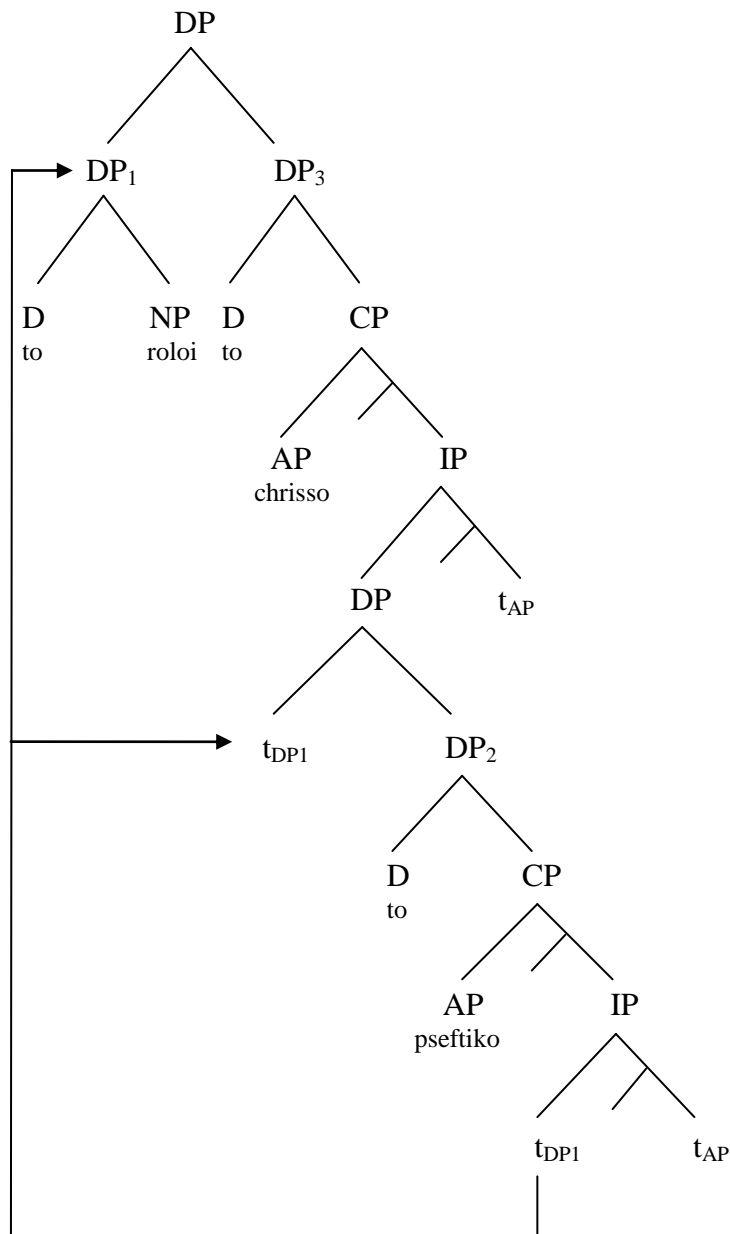

The above derivation should not exist, since it makes available a reading for this string that is unavailable according to native speaker judgments.

The fact that Alexiadou & Wilder's proposal overgenerates in the way shown above is undoubted. At this point, there seems to be no way for this specific analysis to confront this problem.

Before mentioning some more shortcomings of Alexiadou & Wilder's (1998) proposal, it is worth making a clarification on their basic generalization. These authors put forward their Kayne-style analysis based on the fundamental assumption that adjectives that cannot be used predicatively do not allow DS (see (32) above). This claim is correlated with the distribution of non-intersective adjectives, such as ethnic adjectives like *elinikos* 'Greek' (see also Alexiadou, 2001). The latter cannot be used predicatively, according to Alexiadou & Wilder, and so DS with these adjectives is excluded. This is the first problematic point. It seems that this generalization is on the right track. It is true that the so-called ethnic adjectives¹² should be excluded from polydefinites. Consider though the following example, where it appears that such adjectives are marginally acceptable, when appeared in DS:

- (44) a. ? i izvoli itan italiki
 the invasion was Italian
 b. ? i italiki i izvoli
 the Italian the invasion

Moreover, some apparently non-intersective adjectives, like *pseftikos* 'fake', can also be used predicatively and therefore are compatible with DS, as shown throughout this chapter. This issue, namely why such non-intersective adjectives allow DS, will be further discussed in chapter 3.

¹² See chapter 3 for a more detailed discussion of the status of ethnic adjectives. It will be explained why such adjectives can partake in the polydefinite construction (contra Alexiadou & Wilder's claims), being somewhat marginally tolerated.

Second, Alexiadou & Wilder's proposal radically differs from the analysis of monadics, which are associated with the standard DP structure, as in (45):

(45) $[_{DP} \text{ to } [_{NP} \text{ AP chrisso } [_{NP} \text{ roloi}]]]$

This can lead to quite undesirable results. As Kolliakou (2004) notes, it is possible for a Kayne-style DP to occur inside a polydefinite instead of presenting a standard modification structure. This is not blocked by any account. This fact may cause undesirable ambiguity. Consider and compare e.g. (46a) with (46b):

(46) a. $[_{DP} \text{ to } [_{CP} \text{ mikro}_i [_{IP} [_{DP} \text{ to } [_{NP} \text{ kitrino trapezi}]]] t_i]]]$
 b. $[_{DP} \text{ to } [_{CP} \text{ mikro}_i [_{IP} [_{DP} \text{ to } [_{CP} \text{ kitrino}_j [_{IP} \text{ trapezi } t_j]]] t_i]]]$

On the other hand, DPs in DS involve a whole verbless clause as a complement to a determiner which stands in an external position. The determiner is straightforwardly associated with the nominal in [Spec,IP]. Thus, we can have movement of AP predicates and movement of entire DPs to specifiers of other DPs. All those movements have no obvious triggers. That is, the motivation for such movements is quite unclear¹³. This problem appears widely in their analysis, since every different ordering is derived via movement operations. Recall that in our proposal the various orders are derived without recourse to movement.

Third, it appears that a D A D N sequence can be split by movement in ways that are completely unexpected under the LCA-based account:

¹³ Cf. Kolliakou (2004), Panagiotidis (2005).

- (47) to CHRISO thelo to roloi
 the GOLDEN I-want the watch

This fact suggests that the sequence D+A (with the null noun) forms a constituent. Indeed, this is captured in our proposal, but for Alexiadou & Wilder’s this seems to be a problem, since the determiner stands in an external position, with the remaining material forming its CP- complement.

Fourth, if the underlying structure of a polydefinite does indeed contain a CP projection, then it is unclear why any kind of CP-internal material, such as adverbials, cannot ever be present. Indeed, the systematic absence of such elements seems completely unexpected. For instance, no temporal adverbial is allowed in a polydefinite construction:

- (48) * to mikro perisi to trapezi
 the small last year the table

Finally, Alexiadou & Wilder’s analysis does not account for the fact that polydefinites always have a restrictive interpretation. As already noted, this is a core property of polydefinites and a successful analysis should have something to say about it.

Before closing this section, it is worth seeing why Alexiadou & Wilder reject a treatment of polydefinites in terms of apposition. They claim such an analysis

“would be on the wrong track”¹⁴. They use as evidence two examples, which I transcribe here with the corresponding structure they provide¹⁵:

- (49) a. to spiti to megalo, paljo ke grizo, ...
 the house the big, old and grey, ...
 b. [DP to spiti to megalo], [AP PRO paljo ke grizo], ...
- (50) a. to spiti to kokino, to megalo, ...
 the house the red, the big, ...
 b. [DP to spiti to kokino], [DP to megalo [NP e]], ...

Alexiadou & Wilder say that two types of appositive structure can be identified. First, the appositive AP can occur at the right periphery of the DP, set off by pauses, as in (49a). They mention that such APs do not permit DS, but they involve a depictive AP externally to DP, which is assigned the structure in (49b). Second, a D+A string can occur at the right periphery of DP (see (50a)), which is again set off by comma intonation. This is considered by the authors a DP in apposition, with the structure in (50b).

Based on these examples, I think that Alexiadou & Wilder reject an analysis of polydefinites in terms of apposition for the wrong reasons. Clearly, these examples are instances of loose apposition or parentheticals, since there is comma intonation, they do not form an integrated intonational unit and they are not referential¹⁶. In both (49a) and (50a), while the first DP refers to a unique entity, the second just provides additional information for that entity. However, Alexiadou &

¹⁴ Alexiadou & Wilder (1998: 315).

¹⁵ Cf. Alexiadou & Wilder (1998: 315-16).

¹⁶ Recall the relevant discussion in section 2.2.

Wilder do not discuss any reason why an analysis of DPs in DS in terms of *close apposition* would be on the wrong track.

2.5 On DP-internal movement

In section 2.2, we introduced a base-generation analysis which captures adequately all the relevant data of polydefinites. In this way the problem of overgeneration observed in the LCA-based account disappears, provided movement is not generally available in such structures. We should therefore investigate whether there is a principled way to rule out such unwanted movement.

2.5.1 DP-internal movement as a free option

Greenberg's (1963) Universal 20 refers to linear asymmetries found in the nominal projection. More precisely, it states (i) that in pre-nominal position the order of demonstrative, numeral and adjective conforms to the order $\text{Dem} > \text{Num} > \text{A}$ and (ii), that in post-nominal position the same elements conform either to the order $\text{Dem} > \text{Num} > \text{A}$ or to the order $\text{A} > \text{Num} > \text{Dem}$.

The recent literature on Greenberg's Universal 20 (see Cinque 2005, Abels & Neeleman 2006) suggests that DP-internal movement is not unconstrained and obeys at least the following restrictions:

- (51) a. all (relevant) movements move a sub-tree containing N;
b. all movements target a c-commanding position;
c. all (relevant) movements are to the left.

See Abels & Neeleman (2006)

Suppose we make the non-trivial assumption that these constraints also apply in polydefinites. In that context, we will take (51a) to imply that movement must target a constituent that includes the DP containing the overt noun. As I will now show, even this restricted movement theory will lead to considerable complications for the analysis of polydefinites with which I opened this chapter.

The phrase *to pseftiko to roloi to chrisso* ‘the fake the watch the golden’ yields ambiguity between an unmarked and a marked reading. It can be interpreted as “a golden watch which is fake” (unmarked, see structure in (20)) and “a fake watch which is golden” (marked, see structure in (21)). But, the marked reading captured by (21) can also be derived by a movement operation, as in (52):

(52) *Marked source*

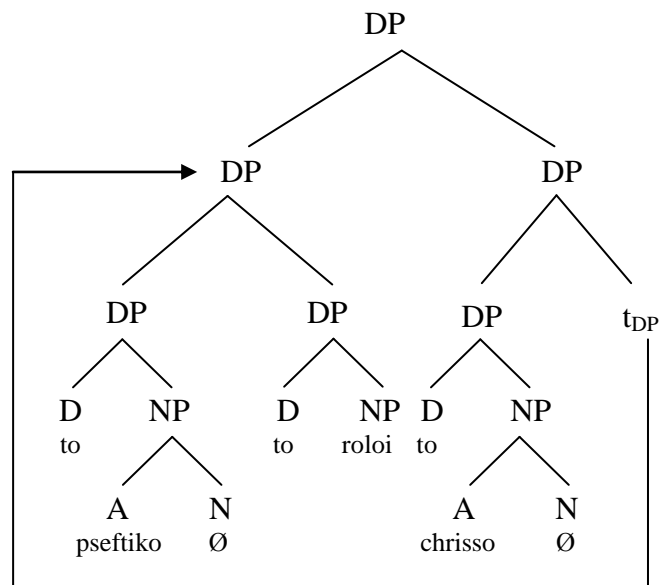

The issue of redundancy also arises in connection with the phrase *to chrisso to roloi to pseftiko* ‘the golden the watch the fake’. This ambiguous string was associated with the structures in (24) and (25). However, the unmarked structure can be derived using movement as well:

(53) *Neutral source*

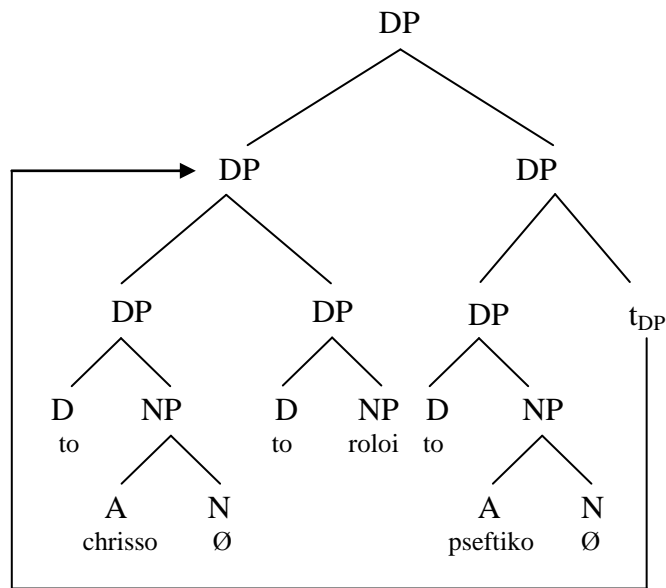

However, the problems introduced by allowing movement in polydefinites are not restricted to mere redundancy. The phrase *to roloi to pseftiko to chrisso* ‘the watch the fake the golden’ has a marked reading. Its structure was depicted in (22). But, the same order can be derived from the neutral source through movement of *to roloi*, as shown in (54):

(54) *Neutral source*

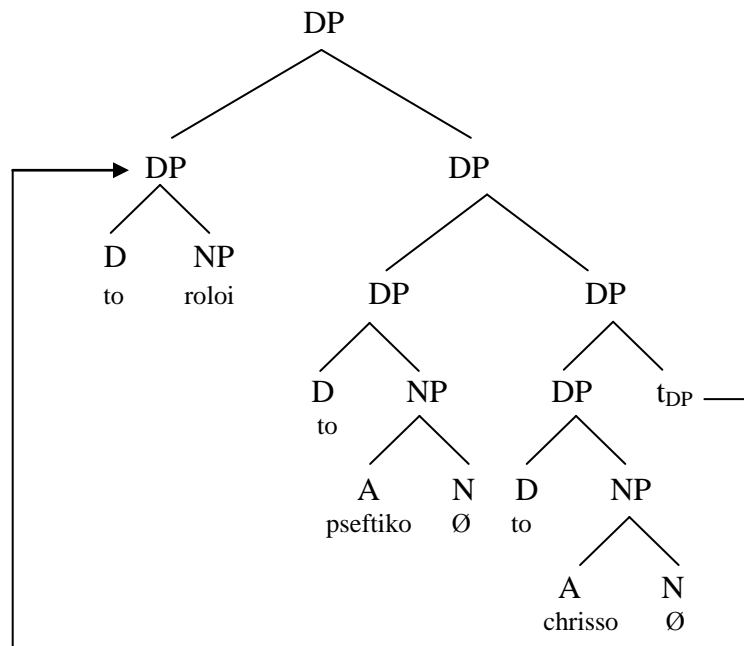

That movement makes available readings that are not available to native speakers is further confirmed when we consider the phrase *to roloi to chrisso to pseftiko* ‘the watch the golden the fake’. This string has an unmarked reading and the associated structure appeared in (23) above. However, the same string can be derived from a marked source through a movement operation:

(55) *Marked source*

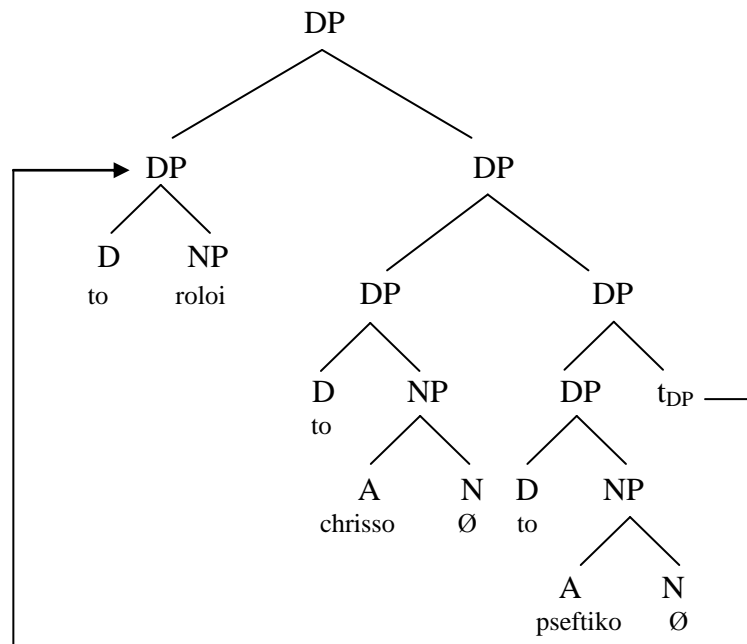

We may conclude that allowing movement internally to polydefinites, even if constrained, leads to overgeneration. Needless to say, this is undesirable. We must therefore ask whether there is a principled way to exclude movement in such structures. There appear to be two potential avenues to explore: a) a blocking account, b) to claim that there is no trigger for DP-internal movement.

Given the data overview above though, it seems that a blocking account is not viable. Such an account allows a base-generated structure to block a movement structure with the same interpretation. But as we have just seen, movement leads also to overgeneration: it assigns structures to strings that represent unavailable readings. Therefore, a blocking account is simply not viable.

In the next section, I will discuss the second alternative; that is, whether DP-internal movement is plausible or not.

2.5.2 Is there DP-internal movement?

Szendrői (2010), adopting Neeleman & Van de Koot's (2008) flexible theory of topic and focus movement, argues that such movements cannot take place within the DP. According to Szendrői (2010), this is due to two reasons: First, the DP is argumental and not propositional. Thus, topic/comment or focus/background partitioning of a DP is excluded. Second, on Neeleman & Van de Koot's (2008) theory of topic and focus movement, such movement is driven by the need to create continuous comment or background constituents. This implies that DP-internal topic and focus movements cannot give rise to a clause-level topic/comment or focus/background partitioning either.

Szendrői (2010) uses the following two examples to show that topic/comment and focus/background structure cannot exist inside the DP.

- (56) a. This tie, FRED bought (Cormack & Smith, 2000: 390)
b. NOTHING I ate for breakfast (Cormack & Smith, 2000: 397)

Reinhart (1981) claims that when an utterance is assessed in context, this involves “checking predication”. This means that one expression in the sentence is taken as the argument and the rest as the predicate. In different syntactic structures, syntax may constrain what the topic (the argument of predication) may be. For example, in passives the topic must be the subject, whereas in clitic-left dislocation, the topic is always the dislocated element. In sentences like (56a), the topic is distinguished by its position, while the rest of the utterance is the comment.

Focus is the element(s) of an utterance which constitutes the answer to a corresponding (implicit) *wh*-question. The background associated with the focus

determines the set corresponding to the implicit *wh*-question. In particular, the background is an open proposition, which can be matched to a set of alternatives. In utterances like (56b) the focus is syntactically displaced (fronted), while the rest of the sentence constitutes the open proposition, which is the background.

Taking the above assumptions as a point of departure, Szendrői (2010) argues that a topic/comment or a focus/background structure cannot exist inside the DP. As already mentioned, both the comment and the background constitute an open proposition, so that the notion of topic and focus are intrinsically associated with propositions. Since a DP does not have propositional semantics, it follows that topic or focus movement internally to DP cannot create a topic/comment or focus/background structure inside that DP.

Neeleman & Van de Koot (2008) suggest an analysis of sentences involving moved topics and foci, such as (56a) and (56b), that is radically different from the standard cartographic approach, which assumes discourse-related functional projections (TopicP and FocusP), as in Rizzi (1997). They argue that topic and focus movement do not target a specific functional position in the tree, but rather these constituents undergo A-bar movement followed by adjunction. As already mentioned the trigger for this movement is that it creates a continuous comment or background constituent. This results in a transparent mapping between syntax and discourse structure at the interface. Notice, on the other hand, that the trigger in the cartographic treatment comes from the corresponding functional head. So, Neeleman & Van de Koot preserve the minimalist assumption that all movement must have an effect on the interface but they opt for a flexible syntactic realization, contra the assumption of rigidly ordered functional positions. As these authors show, this

proposal makes correct predictions about the distribution of topics and foci, some of which are harder or impossible to obtain in the cartographic approach. While, discussing these is beyond the scope of this work, the important prediction for the purposes of this chapter is that it rules out focus and topic movement inside the DP.

Recall that comments and backgrounds constitute open propositions, so that it is impossible to create comment/topic and focus/background partitionings of a DP. If it is assumed that the trigger for topic and focus movement is to create a continuous comment or background, such movement also cannot take place inside the DP with the aim to create a topic/comment or focus/background structure at the clause-level. This is because such movement would not result in a continuous comment or background. Put differently, in spite of the fact that the topic or focus of a sentence can be smaller than a DP, movement of such constituents within their own DPs would leave the comment or the background discontinuous. In Neeleman & Van de Koot's system, this means that the movement is not warranted by an appropriate interface effect and thus, cannot take place.

Nevertheless, there are proposals in the literature which adopt DP-internal focus or topic movement. These are concerned with adjective reordering inside the DP and with the Greek polydefinite construction. For obvious reasons, I will be occupied only with the latter.

Ntelitheos (2004) analyzes discontinuous DPs, NP-ellipsis and polydefinites in a unified account. In Greek, the fronted part of a discontinuous NP is focused:

- (57) to prasino diavasa to vivlio
the green read-1SG.PST the book
 “It is the green book that I read”

Moreover, the second part can easily undergo NP-ellipsis, even if the first part remains in situ.

- (58) to PRASINO diavasa
the green read-1SG.PST
 “It is the green one that I read”

In addition, the first part of the DP need not move, giving rise to what is called the polydefinite construction (see also Kolliakou, 2004):

- (59) diavasa to prasino to vivlio
Read-1SG.PST the green the book
 “It is the green book that I read”

Ntelitheos (2004: 10) proposes that all the three constructions rely on the same structure, which involves focus movement inside the DP. The fronted part moves to a DP-internal FocusP; the elided part moves into a DP-internal TopicP. This is the analysis of the polydefinite in (59). The TopicP inside the DP undergoes deletion in (58) and the DP-internal FocusP undergoes further movement to the clausal FocusP in (57).

But as Szendrői (2010) shows, there is a serious problem that undermines this treatment of the data. There are languages, like Hungarian, that allow discontinuous

NP-topicalization and NP-ellipsis, where DP-internal focus fronting is not possible. This is unexpected in an account where both these constructions rely on the availability of DP-internal focus fronting. Consider the following examples from Hungarian:

- (60) a. Bicikliket, a nagyokat vettem
bikes-ACC the big-PL-ACC bought-I
 “Bikes, I bought the big ones.”
- b. A nagyokat vettem
the big-PL-ACC bought-I
 “I bought the big ones.”
- c. *_[DP A biciklik(et) nagyok(at) t_N] vettem meg
the bikes-ACC big-PL-ACC bought-I prt
 “I bought the big bikes.”
- d. *_[DP A nagy(okat) Péternek t_A bicikliei(t)] vettem meg
The big-PL-ACC Peter-DAT bikes-POSS3SG-PL-ACC bought-I prt
 “I bought Peter’s big bikes.”

Adapted from Szendrői (2010: 871)

In (60a), there is a case of discontinuous DP-topicalization; (60b) shows NP-ellipsis; (60c) and (60d) demonstrate that focus movement inside the DP is impossible. More specifically, (60c) involves movement of the N over the A, while (60d) involves movement of the A over the possessor. The problem with these examples is due to the presence of double accusative marking, indicated with brackets around the accusative markers. The Hungarian data suggest that the merits of Ntelitheos’ analysis must be evaluated only with respect to the polydefinite construction, since NP-ellipsis and discontinuous NP-topicalization are independent from DP-internal focus movement. According to Ntelitheos these two phenomena give rise to the

polydefinite construction. Thus, the query boils down to whether or not the latter involves DP-internal focus fronting. But as argued in this chapter the polydefinite construction does not involve movement at all; all the possible orderings are base-generated. Moreover, as claimed by Kolliakou (2004) and further argued by Szendrői (2010), it appears that the pragmatic import of the polydefinite is not focusing the adjectival part, but rather deaccenting the nominal part¹⁷. This crucially undermines a DP-internal focus movement analysis in a fundamental way. Consider the following example, where (*ι*) stands for infelicitous phrases:

- (61) a. Mary: Ti agorase o Yorgos htes?
 “*What did Yorgos buy yesterday?*”
- b. Joanna: (Agorase) to prasino VIVLIO.
 “*(He bought) the green book.*”
- b’. Joanna: *ι* (Agorase) to PRASINO vivlio.
 “*(He bought) the green book.*”
- b’’. Joanna: *ι* (Agorase) to vivlio to prasino.
 “*(He bought) the book the green.*”
- c. Mary: Agorase o Yanis to kokino vivlio?
 “*Did Yanis buy the red book?*”
- d. Joanna: (Agorase) to vivlio to BLE.
 “*(He bought) the book the blue.*”
- d’. Joanna: (Agorase) to BLE vivlio.
 “*(He bought) the blue book.*”
- d’’. Joanna: *ι* (Agorase) to ble VIVLIO.
 “*(He bought) the blue book.*”

¹⁷ See Van Deemter (1994) and Vallduví & Zacharski (1993) for further discussion of the association of deaccenting with some anaphoric device of concept-givenness or some notion of informativeness or interestingness respectively.

In (61), we can see a characteristic context that favours the appearance of a polydefinite. Assuming a unique green book is available, Joanna can answer Mary's question in (61a) by employing a simple monadic, with the focal pitch accent on the noun, as in (61b). On the other hand, the same monadic with the accent on the adjective, as in (61b'), would be infelicitous, as well as the polydefinite in (61b''). Both the latter would of course be acceptable once properly contextualized. As demonstrated in (61d), the polydefinite is licensed if the noun *vivlio* 'book' is accessibly given information. Deaccenting the noun in the monadic construction, as in (61d'), is also possible in this context. In this case the use of a polydefinite (or a deaccented noun) is not an option but a requirement: the blue book is here contrasted with the previously mentioned silver one. Recall, however, that as mentioned in section 2.3 and remarked by Kolliakou (2004) the explicit contrast between one or more alternatives is not a necessary condition for felicitously using a polydefinite. Rather, it suffices that the polydefinite narrows down a given pool of referents by picking out a proper subset of it¹⁸. Thus, following Kolliakou, it is concluded that the pragmatic import of the polydefinites seems to be the deaccentuation and therefore givenness-marking of the nominal part, rather than the focusing of the adjectival part.

2.6 Concluding remarks

Before closing this chapter, it would be interesting to give an overview of some DS data which present a kind of peculiarity. This concerns instances, in which numerals

¹⁸ See also the relevant discussion in chapter 3.

partake in the polydefinite construction, like e.g. *ta dyo ta megala ta vivlia* ‘the two the big the book’. Let us see what happens in this case.

2.6.1 Polydefinites with numerals

As might be expected, we should have six possible, fully grammatical orderings, as shown in (5). It seems though, that this is not the case. For reasons that are rather unclear to me at this point, here is the situation for polydefinites with numerals:

- (62)
- | | | | | | | | |
|----|----|------------|--------------|------------|--------------|------------|--------------|
| a. | | ta | dyo | ta | megala | ta | vivlia |
| | | <i>the</i> | <i>two</i> | <i>the</i> | <i>big</i> | <i>the</i> | <i>books</i> |
| b. | | ta | dyo | ta | vivlia | ta | megala |
| | | <i>the</i> | <i>two</i> | <i>the</i> | <i>books</i> | <i>the</i> | <i>big</i> |
| c. | | ta | vivlia | ta | dyo | ta | megala |
| | | <i>the</i> | <i>books</i> | <i>the</i> | <i>two</i> | <i>the</i> | <i>big</i> |
| d. | ?? | ta | vivlia | ta | megala | ta | dyo |
| | | <i>the</i> | <i>books</i> | <i>the</i> | <i>big</i> | <i>the</i> | <i>two</i> |
| e. | ?? | ta | megala | ta | vivlia | ta | dyo |
| | | <i>the</i> | <i>big</i> | <i>the</i> | <i>books</i> | <i>the</i> | <i>two</i> |
| f. | | ta | megala | ta | dyo | ta | vivlia |
| | | <i>the</i> | <i>big</i> | <i>the</i> | <i>two</i> | <i>the</i> | <i>books</i> |

As shown in (62), when the numeral is found in the right-most position the phrase becomes ill-formed, contrary to what happens with a normal adjective. This remains an open issue.

Typically, in a monadic phrase in Greek, the numeral precedes the adjective and the noun, like for example: *ta dyo megala vivlia* ‘the two big books’. Inversion of the position of the numeral and the adjective leads to markedness: *ta megala dyo*

vivlia ‘the big two books’. This markedness seems to disappear more or less in the polydefinite (compare (62a) with (62f)). The same is true of the reordering of adjectives in polydefinites (see (5)). This, too, does not give rise to the same markedness effects as reordering of adjectives in monadics. I will develop these observations in chapter 3, answering, among others, the crucial question of what determines markedness effects in monadics and polydefinites.

2.6.2 Conclusion

In this chapter, I have argued that Greek polydefinites are best analyzed on a par with close apposition. The fact that these constructions have a number of major properties in common (e.g. they both form one intonational unit, their sub-parts are independently referential, they are made up necessarily from nominal elements, etc.) seems to favour such a proposal. Following Lekakou & Szendrői (2007), I adopted a multi-headed structure for both polydefinites and close appositives.

I argued for a base-generation analysis of the various ordering possibilities of Greek polydefinites, followed by a discussion of the R-role identification proposal and the shortcomings it involves. I then introduced a new interpretive mechanism, that of Referential index identification, which captures the property that each DP-part of a polydefinite construction is referential and predicts the nonexistence of D A A D A N sequences. It also captures the fact that polydefinites involve restrictive modification.

This was followed in section 2.4 by discussion of the LCA-based analysis of polydefinites of Alexiadou & Wilder (1998) and a detailed criticism of its various

shortcomings, including the overgeneration problem previously noted by Kolliakou (2004).

In section 2.5, I investigated the results of allowing movement as a free option for capturing the relevant orderings of polydefinites and showed that it gives rise to redundancy and overgeneration problems. Out of the two potential avenues to escape from these problems, I rejected a blocking account, since such a hypothesis is not viable. I then discussed why it seems logical to assume that there is no DP-internal movement at all, on the grounds that there is no trigger for such movement. This supports the analysis of polydefinites proposed in this chapter, which does not involve any kind of movement. Notably, there seems to be no possibility to formulate a similar solution to salvage the LCA-based account.

CHAPTER 3

The Interpretation of Polydefinites

3.1 Introduction

The present chapter investigates the interpretive relations in Greek polydefinites. My primary aim will be to show that interpretive differences between monadics and polydefinites fall out naturally from fairly standard assumptions about adjectival modification in conjunction with the syntactic analysis of polydefinites presented in chapter 2. In particular, I will argue that the interpretive differences between monadics and polydefinites give strong support for an analysis of the latter along the lines of the mutual adjunction proposal of chapter 2 and against analyses that treat polydefinites as involving a single extended nominal projection.

In section 3.2, I introduce some fairly minimal assumptions about adjectival modification in monadics and then discuss how these carry over to polydefinites. I will introduce a distinction between the grammar-external concept of ‘default search order’ and the semantic hierarchy for adjectival modification (as outlined for English by Bloomfield 1933, Whorf 1945, and Vendler 1968, among others), which I take to be its grammaticalized counterpart. This distinction will then be shown to be sufficient to capture differences in markedness effects associated with deviations from the default adjectival order in monadics and polydefinites. I also discuss whether marked orders in monadics are associated with focus movement or not. Furthermore, I present some previous analyses of polydefinites that relied on a single nominal extended projection, which I argue to be wrong. I also present some data

from Sproat & Shih (1991), who discuss indirect modifiers that manifest the same absence of markedness as polydefinites.

In section 3.3, I revisit the interpretive effects of the R-index mechanism, introduced in chapter 2. More specifically, I will demonstrate that the distinction between external and internal modification that the R-index mechanism involves has various interpretive effects. Under this perspective, I focus on the controversy over whether DS is licensed by certain adjectival semantics or by specific contextualization. Furthermore, I try to investigate the reason why some adjectives seem to resist DS in any case. In this way, I will show that polydefinites are only compatible with a restrictive reading, as predicted by the interpretive mechanism. I also compare my external modification proposal to Sproat & Shih's indirect modification.

Finally, section 3.4 will conclude the chapter by outlining the connection between the semantic evidence presented in this chapter with the base-generation analysis of chapter 2.

3.2 Modification in monadics and polydefinites

As we have seen in chapter 2, polydefinites are instances of adjectival modification. The question that naturally arises is whether this modification is similar to that seen in monadics or not. Before attempting to offer an answer to the above question, let me first discuss some basic assumptions concerning modification in monadics.

3.2.1 Modification in monadics

Multiple adjectival modifiers in monadics typically obey quite strict ordering restrictions. In numerous descriptions (see Bloomfield, 1933; Whorf, 1945; Lance, 1968; Vendler, 1968; Quirk et al., 1972 among others) the order of pre-nominal adjectives in English and other languages (including Greek) observes the semantic template in (63):

- (63) SUBJ. COMMENT < QUANTIFICATION < QUALITY < SIZE < AGE <
 SHAPE/COLOUR < PROVENANCE
- a. The nice small black Italian box
 - b. The delicious little square Swiss chocolate

According to Laenzlinger (2005: 650-51) the ordering in (63) is reflected in a hierarchy of positions associated with distinct classes of adjectives (see also Cinque 1993 and Alexiadou 2003, among others; in what follows I will refer to such a sequence of functional projections as a ‘Cinque hierarchy’). Put differently, on this view the semantic hierarchy in (63) is directly enforced in syntax through a sequence of DP-internal functional projections. For instance, following Abney’s (1987) proposal for the DP-structure, the intervening adjectives between D, the highest functional head, and N, the lexical head, are positioned in such a way that their top-down route of merging corresponds to their left-to-right ordering. This is depicted in the following tree, which is adapted from Laenzlinger (2005: 651):

(64)

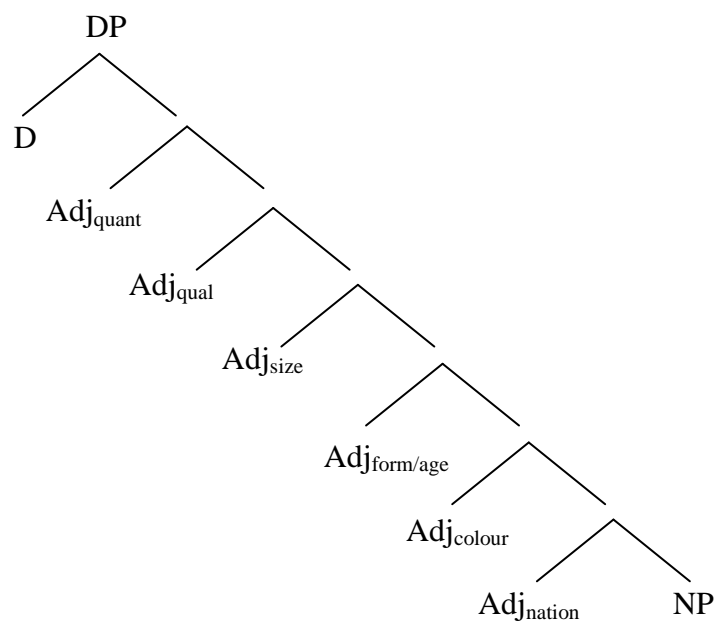

Deviations from the general scheme exemplified in (63) can lead to ill-formedness, at least under neutral intonation and stress (compare e.g. (65a) with (65b)):

- (65) a. The small yellow table
 b. * The yellow small table

However, there are also orderings that deviate from the pattern in (63) that are nevertheless considered acceptable. As (66a) shows, such cases may exist if two or more APs constitute separate prosodic units (separated by comma intonation). Moreover, stressing/focalizing the initial adjective in (66b) licenses a marked reading contrary to that of (65a), which is the neutral, the unmarked.

- (66) a. The bright green, extremely small jewel
 b. The YELLOW small table

Why do we perceive a contrast between (65a) and (66b)? This cannot strictly be a matter of scope. After all, there are no truth-conditional distinctions between *John prefers the small yellow table* and *John prefers the yellow small table*. Rather, what is at stake here appears to be a default way of carving up the world. All else being equal, we are more inclined to sort items by colour before we sort them by size (I will adopt the notation *colour* >> *size* to express precedence of colour-sorting over size-sorting). But of course, all else is not always equal. If we face a situation in which sorting of tables by size has already taken place, then it is perfectly natural, to identify a group of tables of a certain size and to select from that group a table of a particular colour. It is in such a situation that it would be quite natural to produce a marked adjectival order and say *John prefers the YELLOW small table*.

In some cases, the linguistic expression of the sorting order just discussed has truth-conditional implications. For example, the expression *a fake golden watch* is compatible with more situations than the expression *a golden fake watch*. This is because a fake golden watch may or may not be golden, whereas a golden fake watch is definitely golden (I will adopt the notation *fake* > *golden* to express scope of *fake* over *golden*). However, suppose we know we are dealing with fake and non-fake watches, all of which are either (non-fake) silver or (non-fake) golden. In that situation, the expressions *a fake golden watch* and *a golden fake watch* are truth-conditionally equivalent, and which one we choose would depend on ‘sorting order’ in exactly the same way as described above. For example, if we had just sorted the watches into fake and non-fake watches, then it would be quite natural to ask for a golden fake watch, whereas it would be pretty unnatural to ask for a fake golden watch.

Note that the interaction between sorting order and scope implies that sorting order is mapped onto hierarchical relations. For this reason, I occasionally refer to sorting order as scope¹⁹, even if sorting order, unlike true scope, has no truth-conditional impact.

I now turn to modification in polydefinites.

3.2.2 Modification in polydefinites

The syntactic analysis of chapter 2 makes clear predictions about the sorting orders that a particular polydefinite is compatible with. For example, in the phrase *to pseftiko to chrisso to roloi* ‘the fake the golden the watch’, *to pseftiko* was assumed to have scope over *to chrisso*, while this relation is reversed in *to chrisso to pseftiko to roloi* ‘the golden the fake the watch’. It is therefore predicted that the first of these is compatible with more contexts as the second (as was the case with their monadic counterparts) and this prediction is correct.

Suppose we refer to the adjective *pseftiko* ‘fake’ as A_1 , and to the adjective *chrisso* ‘golden’ as A_2 . Then, (67) shows all the potentially available orders:

- (67) a. D A_1 D A_2 D N
 b. D A_1 D N D A_2
 c. D N D A_1 D A_2
 d. D N D A_2 D A_1
 e. D A_2 D N D A_1
 f. D A_2 D A_1 D N

¹⁹ Recall that during the presentation of my proposal for the structure of polydefinites, I used the term scope in order to identify the structural relations between the adjectives and the noun within the polydefinite construction.

As expected, the strings in (67a) and (67d) are only compatible with the default sorting order (A1 >> A2). Again, as expected under the base-generation analysis, the strings in (67c) and (67f) are only compatible with the marked sorting order (A2 >> A1). Thus, they are only felicitous in contexts that call for the set of watches to be carved up along the fake/non-fake dimension²⁰, prior to intersection with *golden*. (As a result, they only permit a reading according to which we are talking about fake watches that are indisputably golden.) Finally, the strings in (67b) and (67e), which the base-generation analysis associates with two structures, can indeed be used in contexts with the marked sorting scenario (in which case they are also associated with wide scope for *golden*), but are also fully compatible with the default sorting order.

On the basis of what we have seen so far, one might be led to conclude that the semantic hierarchy (or its implementation in a Cinque hierarchy) applies in polydefinites just like it does in monadics. However, this would overlook the fact that native speakers judge the markedness effects in polydefinites as much weaker than in monadics. For example, the monadic DP *to chrisso pseftiko roloi* ‘the golden fake watch’ is less acceptable than the polydefinite version of the same DP *to chrisso to pseftiko to roloi* ‘the golden the fake the watch’. As I will now argue, this falls out quite naturally from the theory advanced here.

Suppose we treat the semantic hierarchy in (63) as a grammaticalization of the language-external concept of ‘default search order’. We furthermore assume that this hierarchy can only be enforced within a single extended projection. Note that this would constitute a completely uncontroversial assumption for modification in

²⁰ For a discussion on the semantics of the adjective fake – among others – and for the reasons why it can be treated as intersective, see section 3.3.

the sentential domain and that this restriction is implied by proposals in the vein of Laenzlinger (2005), which express the semantic hierarchy syntactically in the form of a Cinque hierarchy. Such a proposal correctly predicts that the effects of the semantic hierarchy should be detectable inside extended projections only, so that polydefinites associated with a marked search order do not incur a grammar-internal penalty, contra monadics. Put differently, the markedness effects in polydefinites reflect a marked search order only and do not violate the semantic hierarchy.

Before closing this section, let me return to the judgments about search order (scope) associated with the abstract structures in (67), for some further clarifications. My judgments are in agreement with those in Kolliakou 2004, but not with those in Alexiadou & Wilder 1998 and Androutsopoulou 1994, among others. More precisely, Androutsopoulou (1994) considers the sixth order in (67), corresponding to *to chrisso to pseftiko to roloi*, ungrammatical rather than marked, while for phrases where the adjectives are post-nominal and the noun in the left-most position, Alexiadou and Wilder maintain that scope relations are relatively free. My own judgments are not in agreement with these, but fit well with the observation in the literature about adjectival modification in monadics that the scope of adjectives in the sequences ADJ-ADJ-N and N-ADJ-ADJ is unambiguous (see Waugh (1977), Dixon (1982), Sproat & Shih (1991)).

More specifically, when there are two or more adjectives on the same side of the noun, one of the two adjectives (the outer) does not modify the substantive immediately, but the constituent formed by the other adjective and the noun. According to Bouchard (1997: 39), who mostly refers to instances from French, "...the relative distance of an adjective from the noun is determined by selectional

factors”. Thus, the adjective which is nearer the noun forms a constituent with it, which is determined by the furthest adjective. A similar opinion is expressed by Laenzlinger (2005), again for French, and by Bosque & Picallo (1996) for Spanish post-nominal adjectives.

As far as the sequence ADJ-N-ADJ is concerned, the scope of the pre-nominal and the post-nominal adjective relative to one another is fairly free (see Bouchard (1997)). It is quite likely that pragmatic factors and/or intonation suggest which reading is the most salient. It is my judgment and that of my informants that much the same is true of comparable orders in polydefinites. Finally, there is one more piece of evidence supporting these intuitions: comma intonation, to which I turn in the following subsection.

3.2.3 Comma intonation and scope

The presence of comma intonation in each of the phrases in (68) below is optional. But the existence of such an option can be used as an additional piece of evidence in order to corroborate the scope relations predicted by the analysis in chapter 2:

- (68) a. the fake, the golden the watch
b. the fake, the watch the golden
b'. the fake the watch, the golden
c. the watch the fake, the golden
d. the watch the golden, the fake
e. the golden, the watch the fake
e'. the golden the watch, the fake
f. the golden, the fake the watch

One can observe that in each phrase in (68) there is only one possibility/one slot in which we can have comma intonation in each Greek polydefinite phrase, except (68b) and (68e), where a second slot becomes available (see (68b') and (68e')), due to the ambiguity these phrases yield.

For instance, in (68a), we can have a comma only after the first adjective. This suggests that this adjective takes wide scope over the constituent formed by the second adjective and the noun. In other words, the adjective which is closest to the noun merges first with the latter, and afterwards the whole constituent gets modified by the outer adjective. The same logic can also apply to the other phrases in (68).

The presence of comma intonation after e.g. the second adjective in (68a) makes the phrase odd; in other words the phrase *the fake the golden, the watch* does not make any sense intuitively. On the other hand, in (68b) there are two possibilities for the appearance of comma intonation; these two possibilities correspond to distinct readings, as expected. These facts taken together, along with the fact that (67c) and (67f) are marked indicate that there are two sources of derivation of the relevant strings; a neutral/unmarked source and a marked source.

3.2.4 Further points

As we have seen in (66), adjective orderings in monadics can be associated with either a neutral/unmarked or a marked reading, with respect to the semantic hierarchy. Under this perspective, the DP *the small yellow table* is unmarked as opposed to the DP *the YELLOW small table*, which is marked. The latter raises the question whether it involves focus movement.

Neeleman & Van de Koot (2007) demonstrate that languages like Dutch permit two different types of scrambling: a) A-scrambling, which interacts with A-binding and secondary predication, does not give rise to weak crossover effects and never reconstructs for scope; b) A'-scrambling, which does not affect binding or secondary predication, gives rise to weak crossover effects and obligatorily reconstructs for scope. Neeleman & Van de Koot suggest that A-scrambling is analyzed as a different base-generated order, thus it does not allow scope reconstruction; by contrast, A'-scrambling, which involves A'-movement permits reconstruction for scope, as expected.

So, do the adjective reordering data pattern with A- or A'-scrambling with respect to scope reconstruction? It turns out that adjectives do not reconstruct for scope. Rather, marked orders have surface scope, so an analysis in terms of different base-generated orders is the only appropriate possibility, since the A'-scrambling analysis makes incorrect predictions regarding scope. To make this clearer, consider the following example:

(69) I bought a *YELLOW small table*.

An utterance like (69) is felicitous in a context where there is a given set of small tables (known to the speaker and the hearer) one of which is yellow. But the same phrase is not felicitous in a context where there is a set of yellow tables one of which is small, alongside other sets of tables of different colours where one of each set is small. This suggests that, in (69), the focused adjective does not reconstruct below

the second adjective for scope. Thus, we do not have DP-internal (focus) adjective movement, instead, an alternative base-generated adjectival sequence.

Let me use one more example, so that the lack of reconstruction can be truth-conditionally verified. Take for instance the following phrase in Greek:

(70) Vrika ena CHRISO pseftiko roloi
 I-found *a* *golden* *fake* *watch*

It is already known that the phrase *ena pseftiko chrisso roloi* ‘a fake golden watch’ yields ambiguity: a) the colour can be fake; b) the watch can be fake. In the phrase *ena CHRISO pseftiko roloi* ‘a GOLDEN fake watch’, the watch is undoubtedly golden (this DP is unambiguous), despite the fact that it is fake. If the adjective *golden* reconstructed for scope, the watch should not have to be golden. But this reconstructed reading is unavailable: the example in (70) yields exactly the same interpretation in its English counterpart, as native speakers confirm. It is thus concluded that the focused adjective does not reconstruct for scope.

Moreover, a derivation involving focus movement is independently ruled out by the constraints on movement that derive Universal 20 (see also chapter 2, §2.5.1). Such a derivation would involve movement of an adjective only, which is banned, because the moved constituent should include the nominal head; of course, this is not the case here.

The analysis of modification in monadics and polydefinites presented above strongly supports an analysis of the former along the lines of mutual adjunction, discussed in chapter 2. As argued, the effects of the semantic hierarchy should be detectable inside extended projections only, so that much weaker markedness effects

are predicted for polydefinites than for monadics. This contrast would be completely unexpected on a single DP account of polydefinites. Such analyses have been proposed in literature.

For example, Androutsopoulou (1995) suggests the extra determiners that appear in polydefinites are instances of a new functional head within the DP projection, which she calls Def^0 (for definiteness). Def^0 is optionally projected above NP and AP, as in (71), and hosts formal agreement features (phi-features, Case and definiteness), which get spelled out by the relevant form of the definite determiner. Crucially, the items introduced under Def are ‘expletive’. The definite article that gets interpreted is hosted by the ‘real’ D^0 -head, the highest head in the extended projection of N. D^0 contains no overt material.

(71)

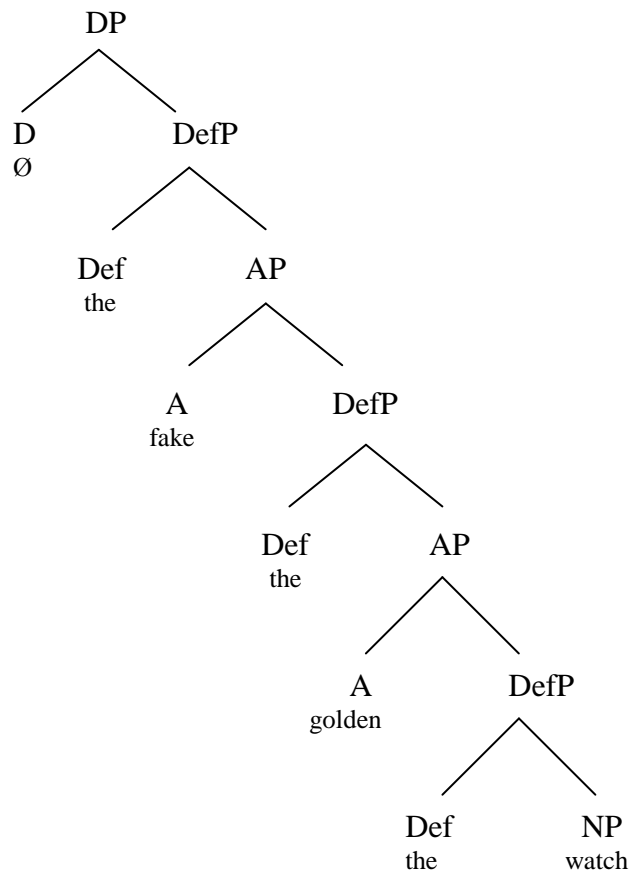

It is not clear how such a proposal could capture the differences in interpretation between monadics and polydefinites.²¹

For Manolissou (2000), the determiner + adjective sequence is located at the specifier position of the NP; the order D + N + D + A is obtained via the obligatory movement of the noun to the head of a functional agreement projection FP lying between DP and NP. The reverse order D + A + D + N is the result of an extra movement of the definite determiner + noun to the Spec of DP.

²¹ In my view, this proposal has further shortcomings. It is unclear what gives rise to the appearance of DefP in Greek DPs. In addition, according to Alexiadou & Wilder (1997), there seems to be no motivation to assume such a category in other languages, nor – apart from the facts it is intended to account for – in Greek. Nor is it evident why APs and NP as well should be governed by such a category.

(72)

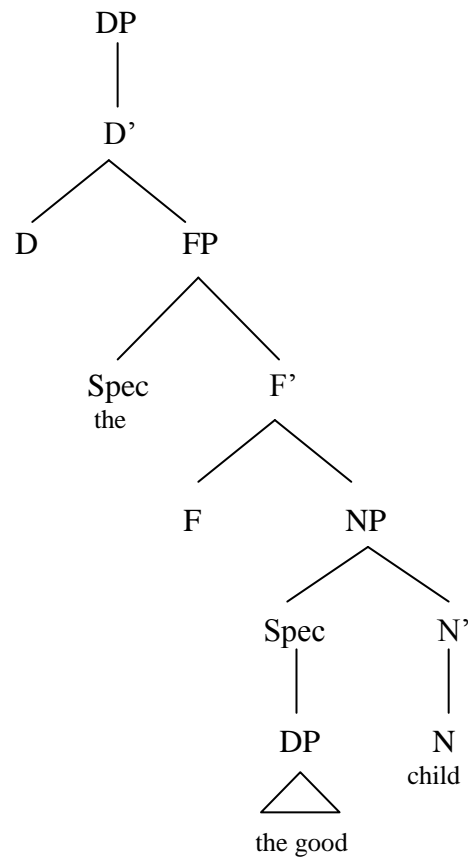

Last, but not least, I should point out that the absence of markedness is not observed only in polydefinites. Sproat & Shih (1991), show, on the basis of the analysis of a number of languages, that in indirect modification²², when there is more than one indirect modifier, no strict order is followed. Consider the following example from Mandarin and compare it with (65) and (66) from English:

- (73) a. SIZE, COLOUR
- | | | |
|-----------------|-----------------|-------------|
| xiaǒ-de | lǜ-de | huāpíng |
| <i>small-DE</i> | <i>green-DE</i> | <i>vase</i> |

²² In a relation of indirect modification the adjective associates theta role to the modified noun indirectly, from inside a modifying relative clause of which it forms part. This is different from direct modification, where the adjective associates its theta role directly with its sister noun (see also the relevant discussion in § 3.3.4).

lǜ-de	xiǎo-de	huāpíng
<i>green-DE</i>	<i>small-DE</i>	<i>vase</i>

b. SIZE, SHAPE

xiǎo-de	fāng-de	zhuōzi
<i>small-DE</i>	<i>square-DE</i>	<i>table</i>
fāng-de	xiǎo-de	zhuōzi
<i>square-DE</i>	<i>small-DE</i>	<i>table</i>

Interestingly, each of the adjectives in (73) is marked with the particle *de*. Recall that in polydefinites each adjective must be preceded by its own determiner. It is also possible to use monosyllabic adjectives in Mandarin to modify NPs without the use of *de* and in such cases ordering restrictions like those found in English reappear, as demonstrated below:

- (74) SIZE > COLOUR
- | | | | |
|---|--------------|--------------|-------------|
| | xiǎo | lǜ | huāpíng |
| | <i>small</i> | <i>green</i> | <i>vase</i> |
| * | lǜ | xiǎo | huāpíng |
| | <i>green</i> | <i>small</i> | <i>vase</i> |

To sum up, in this section we have seen that: a) marked orders do not involve focus movement; b) that the analysis of modification in polydefinites advanced here does not favour any accounts of the latter in terms of a single DP projection; c) there is corroborating evidence from different languages that when multiple indirect

modifiers occur in an NP there is no violation of the semantic hierarchy, exactly as we found to be the case for polydefinites.

3.3 The interpretive properties of the R-index mechanism

In this section, after a short presentation of some core properties of the semantics of adjectival modification, I will present the properties of the interpretive mechanism of polydefinites, introduced in chapter 2. More specifically, I will argue that modification through R-index identification (external modification) and modification internally to each DP either through θ -identification or any other available mechanisms can be distinguished on interpretive grounds, making certain predictions about the restrictive reading of polydefinites, the adjectives that are allowed to partake in the construction and the role of the context.

3.3.1 Some basic notions in the semantics of adjectival modification

A large number of papers have been written on the issue of adjectival modification, not only from the syntactic but also from the semantic point of view. Here, I discuss some very basic properties of the semantics of adjectives that are relevant to this dissertation (for further discussion, see among others Siegel 1980, Partee 1995, Larson 1998, Heim & Kratzer 2005).

For a start, let me refer to a core distinction, namely, that of predicative vs. attributive adjectives. Adjectives are said to occur *predicatively* when they function as the main predicate in a clause or clause-like structure (see e.g. (75)); they are said to occur *attributively* when they function as modifiers in a nominal (see e.g. (76)).

- (75) a. Sandy is **tall**
 b. Max considers [Sandy **tall**]
- (76) a. [Two **big** dogs appeared]
 b. Michael spoke to [an **alleged** liar]

Some adjectives allow readings when used attributively that are unavailable when they are used predicatively. As one would expect given this state of affairs, there are adjectives that cannot be used predicatively at all. The relevant interpretive asymmetry is based on the distinction between so-called intersective and non-intersective interpretations.

The so-called intersective interpretation for attributive adjectives says that both the noun and the adjective are one-place predicates. Following this idea, the interpretation of (77a) is taken to be a simple conjunction of predicates. Its interpretation is in (77b-c):

- (77) a. Fido is a **black dog**
 b. $\text{black}(x), \text{dog}(x)$
 c. $\text{black}(f) \ \& \ \text{dog}(f)$

In other words, we can say that one-place predicates (adjective & noun) pick out sets, and interpret the A-N combination by taking the intersection of their respective sets so as to have the following schema:

- (78) NP is a(n) A N \Rightarrow NP is an A **and** NP is an N

Now consider the ambiguity of (79a) the possible interpretations of which appear in (79b) and (79c) correspondingly:

- (79) a. Mary is a beautiful dancer
 b. "Mary is a dancer and Mary is beautiful" → intersective
 c. "Mary is beautiful as a dancer"/"Mary dances beautifully" → non-intersective

The adjective in (79a) is well-known to be ambiguous between an intersective (79b) and a non-intersective reading (79c).

According to Larson (1998), one could give at least two different kinds of diagnoses of the above ambiguity, ascribing its source either to the adjective (he calls that the “A-analysis”), or to the noun (the “N-analysis”). The former means that perhaps the adjective contains some hidden semantic complexity that reveals itself in combination with a simple noun, whereas the latter signifies that the noun's properties are the ones which ultimately yield the ambiguous result.

Non-intersective adjectives are also known as subsective. If we take, for example, the adjective *skilful* combined with the noun *student*, the meaning of the DP *the skilful student* can roughly be depicted as in the following schema:

- (80) Subsectivity: $\|skilful\ N\| \subseteq \|N\|$ *adapted from Partee (1995)*

Adjectives like *skilful* do not support an intersective reading. If they did, this could lead to a paradox such as the following:

- (81) a. Mary is a skilful student.
 b. Mary is a dancer.
 c. Therefore, Mary is a skilful dancer.

The inference in (81c) would be true if the adjective was intersective. But, it is clearly not valid. In other words, the adjective does not pick out a set of individuals who are skilful, but rather, as Partee (1995) notes, carves out a subset of the set corresponding to the noun it combines with. This simply means that the set of *skilful students* is a subset of the set of students (see also Bouchard 1997).

Not all adjectives fall into the intersective vs. non-intersective/subsective distinction. We can evidently talk about non-subsective adjectives, following Partee (1995). The adjective *former* is said to be privative, as an instance of A+N combination is never an instance of the N alone:

- (82) a. $\| \text{former president} \| \neq \| \text{former} \| \cap \| \text{president} \|$
 b. $\| \text{former president} \| \not\subset \| \text{president} \|$

Moreover, adjectives like *alleged*, *counterfeit*, *possible* etc., which clearly are non-subsective, are said to be plain. For example, an alleged theft may be or may not be a theft. So, as is obvious, the class of non-subsective adjectives can be divided into two sub-classes: a) privative and b) plain. For many non-subsective adjectives it is difficult to say whether they belong to the one or the other sub-class, and in fact the decision may depend on *context* and the domain of *discourse*.

3.3.2 Expanding the notion of intersection

In terms of formal semantics, adjectives like *fake* are considered to be plain/non-subsective (see e.g. Partee 1995). In spite of this fact, the notion of intersection is used here in a more loose way. Intuitively, it seems entirely possible to construct a loose concept of ‘pistol’ that includes both fake and real pistols. That this possibility is actually used in language is confirmed by the fact that the following example is well-formed:

(83) There are three pistols lying on the table. Two real ones and one fake one.

In particular, the assertion in the second sentence that one of the pistols is fake, does not lead us to judge the proposition in the first sentence as false. Given this state of affairs, we can take the computation of the meaning of *the fake pistol* to involve intersection.

The idea that all adjectives are more or less intersective has precedents in the literature. Bouchard (1997), in agreement with Kamp & Partee (1995), says that the lexical entry of a N like *professor* contains a set of properties, or a network of interacting elements which determine the ontology of the N. This network consists of (i) the characteristic function c , which provides the property that interprets N, (ii) the indication of a certain time interval i at which c holds and (iii) the indication of a possible world w at which c holds (see also Kamp, 1975). The aforementioned interacting elements are unified into any given lexical item and so they function as a whole with regard to selection and the licensing of Merge.

There is no need to refer to components of the network for the class of intersective adjectives, which, in terms of formal semantics involve conjunction (set intersection). In other words, we can say that one-place predicates (adjective & noun) pick out sets, and interpret the A-N combination by taking the intersection of their respective sets so as to have the following schema: $\|book\| \cap \|green\|$.

For intersective adjectives, the set of things that have the property of being a noun with characteristic function c , in w at i intersects with the set determined by the adjective. By contrast, there seems to be a group of adjectives (e.g. *alleged*, *future*, and *skilful*, among others) that cannot be analyzed as intersective in any obvious way. This fact has led semanticists to propose that these adjectives are not functions that map sets with sets, but instead properties with properties. In other words, the latter are intensional rather than extensional adjectives. According to Bouchard (1997: 35), “the property that a predicate stands for determines not only its actual extension, but also the extensions it would have in other possible circumstances (i.e., by varying the values of i and w). This spectrum of actual and potential extensions presents an intensional view of the predicate.” Under this perspective a given N could be affected by adjectives like *alleged* and *former* etc. as long as the adjective does not target the entire set of interacting elements c , i , w , but instead only one of those elements, which is related on the meaning of the adjective. Consider, for instance the phrase *the former president*. This means that the person to which this person refers to was a president sometime in the past, but not now. Thus, the adjective *former* modifies a component internally to N, namely time interval i (for a relevant discussion on the distinction between intensional and extensional adjectives see also Alexiadou et al., 2007).

On this view, intensional adjectives can also be regarded as intersective. To make this clearer, let me make the following distinction, along the lines of Bouchard (1997). Standard intersective adjectives are extensional. This means that they affect the set defined by the whole complex of interacting elements internal to N (c , i , w etc.). In the same vein, intensional adjectives are also intersective with one difference; they affect sets defined by a subpart of the network of interacting elements of the N . Modification of a subcomponent of N licenses Merge. For example, the adjective *future* affects the set of time intervals defined by i , and so on.

In spite of the fact that the adjective *fake* is compatible with intersection (see e.g. *fake pistols* in (83)), as shown earlier, Bouchard treats it as intensional, affecting a component internal to N , namely possible world w . This means that the pistol has some of the characteristic properties of a pistol, but apparently something is missing in the relevant possible world w , namely in the real world in our case. This is a pistol but not a real one, as it cannot do whatever a real pistol can do. Hence, the adjective *fake* modifies a component internal to N , that is w . This remains a plausible treatment, but contrary to other intensional adjectives, e.g. *former* and *alleged*, which are indisputably intensional, an adjective like *fake* is also compatible with intersection under a loose concept of e.g. 'pistol'.

In addition, as Bouchard (1998) observes, even intersective adjectives are probably all contextually calibrated. For example, a sheet of paper of the same colour as a white man is not referred to as white. Thus, once contextual calibration is taken into account, a large family of adjectives can be treated as intersective.

3.3.3 The properties of the interpretive mechanism of polydefinites

In many approaches to polydefinites (e.g. Alexiadou & Wilder 1998, Kolliakou 1999, Campos & Stavrou 2004, Leu 2007 among others), an attempt has been made to correlate adjectival class with whether an adjective partakes in the polydefinite construction or not. All the aforementioned authors more or less claim that only the intersective adjectives – in the traditional view of formal semantics – or the adjectives that can be used predicatively support determiner spreading. Although this generalization seems to be on the right track, let me make some further clarifications which would sketch this issue in a more transparent and complete way.

My point of view is that Kolliakou's (2004) view of polydefinites constitutes a good starting point. She argues that polydefinites require a restrictive reading. In her words (Kolliakou, 2004: 270), polydefinites “narrow down a given pool of referents by picking out a proper subset of it”. As Lekakou & Szendrői (2007) remark, this means that a felicitous use of determiner spreading presupposes that it introduces a subset of a set previously mentioned in the discourse or of a set that is otherwise highly accessible.

To make this point clearer, we can compare a monadic with a polydefinite so as to better see the difference as far as restrictiveness is concerned:

- (84)
- | | | | | |
|------------|---------------|----------------|-------------|------------------|
| O | Kostas | potise | ta | louloudia. |
| <i>The</i> | <i>Kostas</i> | <i>watered</i> | <i>the</i> | <i>flowers.</i> |
| Ta | mikra | triandafila | itan | maramena. |
| <i>The</i> | <i>small</i> | <i>roses</i> | <i>were</i> | <i>withered.</i> |

Example (84), which lacks DS, has four possible interpretations:

- a. all the flowers Kostas watered were roses, but there were small and big roses.
- b. all the flowers Kostas watered were roses, but there were only small roses.
- c. Kostas watered roses and non-roses (e.g. tulips), and there were small and non-small roses.
- d. Kostas watered roses and non-roses, and all the roses were small.

Consider now the same example with DS. Only two interpretations are possible. The restrictive reading that the polydefinites induce is evident.

- (85) O Kostas potise ta louloudia.
 The Kostas watered the flowers.
 Ta mikra ta triandafila itan maramena.
 The small the roses were withered.

- a. all the flowers Kostas watered were roses, but there were small and non-small roses.
- b. Kostas watered roses and non-roses, and there were small and non-small roses.

That polydefinites should require a restrictive reading falls out naturally from the interpretive mechanism of R-index identification. An adjective in polydefinites

combines with a null noun, which we may assume to be radically underspecified. Hence, a DP like [*to megalo* \emptyset] in *to megalo to trapezi* ‘the big table’ means something like ‘the big thing’. Forcing referential identity between such an expression and a full DP like [*to trapezi*] ‘the table’, yields the interpretive effect of intersection, but without actual intersection. It is therefore reasonable to claim that the proposed interpretive mechanism is compatible with the restrictive reading required by polydefinites.

The issue we now need to address is why there are restrictions on the types of adjective that are allowed in the polydefinite construction. Some, like *proin* ‘former’ and *ipotithemenos* ‘alleged’ resist DS in any case; whereas adjectives like *pseftikos* ‘fake’ can partake in the construction. This is quite intriguing. How can these facts be explained?

In the best case, the observed restrictions should find an explanation in the structure of polydefinites. Now recall that every adjective that partakes in the construction is accompanied by a null noun. Assuming, as before, that the null noun is a lexical item, it will be severely underspecified. If so, it will not allow modification of any internal component and can therefore only be modified by adjectives that are intersective. It is then correctly predicted that the following DPs are ill-formed:

- (86) a. * \circ *ipotithemenos* \circ *dolofonos*
 the alleged *the murderer*
- b. * \circ *ipotithemenos* \emptyset_N
 the alleged...

- (89) to eliniko eleolado
 the Greek olive-oil
- (90) X: Sou aresi to ladi?
 Do-you like the oil?
- Y: Poli, ala protimo to eliniko to eleolado
 Very (much), but I-prefer the Greek the olive-oil
 apo to ispaniko...
 to the Spanish (one).

As Alexiadou & Stavrou remark, ethnic adjectives do not assign a property to the referent of the noun they modify – hence, their predicative use is odd (see (91a)). By contrast, their relational counterparts can be used predicatively without any problems (see (91b))

- (91) a. ? i izvoli ine italiki
 the invasion is Italian
- b. to tragoudi ine eliniko
 the song is Greek

As mentioned earlier, some adjectives standardly treated as non-intersective, such as *fake*, can in fact be analyzed as involving intersection on a ‘loose’ interpretation of the noun they combine with (see for further discussion, Sperber & Wilson 1998 and Carston & Wilson 2007, among others). We therefore expect this subset of apparently non-intersective adjectives to be felicitous both in predicative use and in polydefinites, as for example:

(92) to pistoli ine pseftiko
the pistol is fake

(93) X: Fere mou to pistoli pou ine sto domatio
Bring me the pistol which is in-the room
 Y: Ipotheto, thelis to pseftiko to pistoli...
I-suppose you-want the fake the pistol...

We are led to the conclusion that concept loosening allows us to treat e.g. a fake watch as a kind of watch, but does not allow us to treat a former president as a kind of president. This is confirmed by the fact that *fake* but not *former* can be used predicatively. Further work will be required to establish the conditions under which concepts can be widened, as it is far from obvious why concepts such as *president* can be extended to include fake presidents but not former presidents. However, such an investigation is beyond the scope of this work.

3.3.4 External modification and indirect modification

Sproat & Shih (1991) argue that adjectival modification cross-linguistically breaks down into two kinds. They call the first kind ‘direct modification’. Direct modification can be further distinguished into hierarchical and parallel modification. In hierarchical modification, it is assumed that the adjective assigns its θ -role(s) directly to its sister, which will be a projection of N, whereas in parallel modification (i.e. in a series of adjectives) each adjective assigns its role directly to the nominal head independently of one another.

The second kind is called ‘indirect modification’ (see §3.2.4 for examples). In this case the adjective’s θ -role(s) are associated with that of its modifiee indirectly

by coindexation, from inside a modifying relative clause of which it forms a part. In particular, the adjective is coindexed with a phonologically empty variable within its clause, which is bound by an operator in CP, which in turn is coindexed with the head noun. Here is the structure they assign:

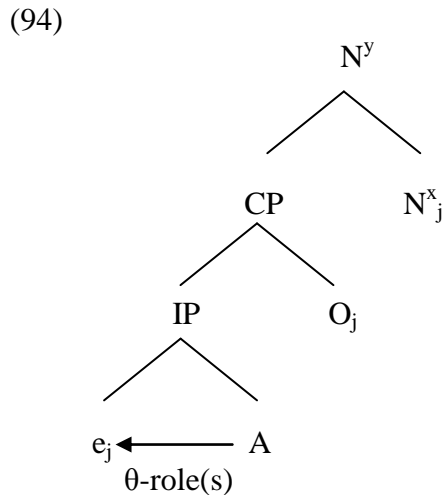

Indirect modification seems to have some common points with the external modification proposal discussed earlier for polydefinites, but some important differences as well.

According to Sproat & Shih (1988, 1991) indirect modification a) is not subject to ordering restrictions and b) permits intersective (predicative) modifiers only. As we have seen the same holds for polydefinites. Ordering restrictions are much looser in polydefinites than in monadics, and lead to very weak markedness effects. The fact that ordering restrictions do not come into play in polydefinites is captured by the external modification proposal: coerced identity is imposed in a mutual adjunction structure that is immune to the effects of the semantic hierarchy. Moreover, as discussed extensively in sections 3.3.2 – 3.3.3, the structure and

interpretive mechanism proposed for polydefinites permits only intersective adjectives, in a looser conception of intersection though.

In our external modification suggestion, the process of coerced referential identity involves an identification of R-indices on the top node. This is quite similar to the coindexation process described above for the indirect modification. It is also known (see chapter 2) that a polydefinite structure can be bound by a higher predicate similarly to indirect modifiers.

On the other hand, the ‘modifying’ DPs in polydefinites were argued to be argumentative rather than predicative. This suggests that they do not involve modification by (reduced) relative clauses, contra what we find with indirect modification, since relative clauses are usually treated in the literature as predicates. The alternative would be to claim that only non-restrictive relatives are predicates. Restrictive relatives would then have to be treated as referential. However, this suggestion lacks initial plausibility, as the vast majority of restrictive relatives cannot be used as an argument. This might be different for the small group of English speakers who produce relatives of the type *the book what I bought*. Clearly, phrases like *what I bought* can be used as an argument, as in examples like *I don’t like what I bought*.

We may conclude that adjectival modifiers in polydefinites are indirect modifiers with some resemblance to DE-modifiers in Mandarin. However, the analysis proposed here differs from that assumed by Sproat & Shih for DE-modifiers in important respects and it is far from obvious that these phenomena can be given a unified treatment.

3.4 Concluding remarks

In this chapter, I discussed the correlation among the sorting order, the semantic hierarchy, the markedness effects and the scope interaction in monadics and polydefinites. My claim is that the search/sorting order is a primitive notion, expressing the way the human mind classifies various domains of the world. In line with this, I suggested that the semantic hierarchy is the grammaticalization of this cognitive process. In monadics, the semantic hierarchy and the search order commonly coincide. As a by-product we have scope interaction if the adjectives have the right properties for that. When the semantic hierarchy and search order do not coincide, this gives rise to strong markedness effects. By contrast, in polydefinites, the semantic hierarchy cannot be enforced, because it holds only within a noun's extended projection only. As a result, deviations from the default sorting order give rise to much weaker effects. Nevertheless, the effects of scope are still detectable. This in turn led us to conclude that search order is represented hierarchically.

Following a discussion of the semantics of adjectival modification, I set out to derive a number of interpretive peculiarities of polydefinites from the structure I proposed for them. First, I argued that identity coercion implied by the R-index mechanism, introduced in chapter 2, yields the effect that adjectives in polydefinites invariably have a restrictive interpretation. Second, I argued that the presence of a null noun following every adjective in a polydefinite imposes restrictions on the kinds of adjective that are found in the construction. More specifically, such adjectives are always extensional and therefore allow a predicative use, as also observed by Alexiadou & Wilder (1998).

Finally, I compared the R-index mechanism with the indirect modification proposal made by Sproat & Shih, suggesting that despite the similarities, the phenomena addressed by these two proposal exhibit substantial differences.

CHAPTER 4

The Syntactic Status of Greek Indefinite DPs

4.1 Introduction

The present chapter is mainly concerned with indefinite DPs in Greek. These DPs present the interesting characteristic of internal word order freedom and an account is to be offered that captures this fact. I will try to determine whether the syntax of post-nominal adjectives in Greek indefinites is similar to that of post-nominal adjectives in Romance indefinites or whether the syntax of Greek indefinites has aspects in common with that of Greek polydefinites.

As discussed in chapters 2 and 3, in Greek polydefinites the noun and each adjective is accompanied by its own definite determiner (determiner spreading, DS). The multiple occurrence of the definite determiner yields considerable word order freedom²³. For instance, in a DP with a noun and two adjectives there are six possible alternations, which are shown in (95), along with their constituency:

- (95)
- a. [to pseftiko [to chrisso to roloi]]
 - b. [to pseftiko [to roloi to chrisso]]
 - (#) b'. [[to pseftiko to roloi] to chrisso]
 - (#) c. [[to roloi to pseftiko] to chrisso]
 - d. [[to roloi to chrisso] to pseftiko]
 - e. [[to chrisso to roloi] to pseftiko]]

²³ As noted in the chapter 2, a pre-adjectival determiner is optional for pre-nominal adjectives, but obligatory for post-nominal ones. Furthermore, while partial determiner spreading is possible, DS cannot skip an adjective, since this leads to ungrammaticality.

(#) e'. [to chrisso [to roloi to pseftiko]]

(#) f. [to chrisso [to pseftiko to roloi]]

Interestingly, indefinite DPs in Greek display the same ordering possibilities as polydefinites. Furthermore, the scope relations among adjectives and patterns of default/marked sorting orders suggests identical constituency, but without indefinite determiner spreading. Thus, while *ena* 'a(n)' appears only in the left-most position of an indefinite DP, adjectives can either precede or follow the noun. The relevant data are illustrated in (96):

- (96) a. ena pseftiko chrisso roloi
 a fake golden watch
- b. ena pseftiko roloi chrisso
 a fake watch golden
- c. (#) ena roloi pseftiko chrisso
 a watch fake golden
- d. ena roloi chrisso pseftiko
 a watch golden fake
- e. ena chrisso roloi pseftiko
 a golden watch fake
- f. (#) ena chrisso pseftiko roloi
 a golden fake watch

The fact that indefinite DPs do not exhibit indefinite determiner spreading is somewhat puzzling, given that free word order in Greek definites requires it.

What is proposed in the literature does not provide a persuasive answer to the question why Greek indefinites should have these properties. For example, Alexiadou & Wilder (1998) propose an LCA-based analysis similar to their

suggestion regarding polydefinites, in terms of restrictive relatives, in an attempt to provide a unified account for both polydefinites and indefinites. However, Alexiadou (2006) rejects this proposal, suggesting that *ena* is not an article, but a quantifier. The main argument for such a proposal is that other quantifiers in Greek also disallow spreading, but simultaneously demonstrate the same ordering permutations, e.g.:

- (97) a. *kathe pseftiko roloi*
 every fake watch
- b. *kathe roloi pseftiko*
 every watch fake
- c. * *kathe pseftiko kathe roloi*
 every fake every watch

An alternative analysis that correlates modification in indefinites with close apposition, along the lines proposed in Lekakou & Szendrői (2007) for polydefinites and discussed in chapter 2, seems unwise, given the widely held belief that apposition requires two definite DPs. Stavrou (1995) argues that there can be no close apposition even if only one part is indefinite:

- (98) a. * *Enas jatros o Yannis*
 a doctor the John
- b. * *O Yannis enas jatros*
 the John a doctor

Indeed, Lekakou & Szendrői (2007), who propose a close apposition analysis of polydefinites, say that the absence of polyindefinites is a natural consequence of their proposal, given that indefinite determiners are impossible in structures of close apposition (for poorly understood reason).

This brings us to the question whether it is really true that there are no polyindefinites. As we have already seen, there is no visible determiner spreading in indefinites. Also there are languages that do not have determiner spreading at all, but that do have post-nominal adjectives. This opens up the possibility that the ordering phenomena in Greek indefinites are very different from those seen in Greek polydefinites. For this reason, I will begin by looking at the syntax of adjectival modification in two Romance languages (French and Spanish). Given that these languages do not present the DP-internal word order variation found in Greek, we should explore whether the analysis of post-nominal adjectives in Romance DPs can be extended to account for the word order freedom found in Greek indefinite DPs.

The rest of this chapter is structured as follows: section 4.2 deals with adjectival modification in French. I will consider the position of adjectives with respect to the N, meaning differences between the N-A and A-N orderings and associated generalizations about adjectival types, and finally available word order alternations and their effects on adjectival scope. I will also present the corresponding data in Spanish, along with their ordering possibilities and scope relations. In section 4.3, I will try to answer what these data suggest and how we can account for the observed relations within them. I present an overview of Bouchard's (1997, 1998) analysis of the facts. Then I point out some inconsistencies it involves, based on data from different languages, including English, Greek, French and

Spanish. I also introduce my own analysis. In section 4.4, I return to Greek indefinites in order to investigate whether they can be analyzed on a par with Romance indefinites. I attempt to determine the syntactic nature of *ena* ‘a(n)’; namely whether it is a determiner or a quantifier. Following that, I try to answer the crucial questions addressed in this chapter, namely: (a) do polyindefinites exist and if so, (b) what is their internal structure? Finally, in section 4.5, I conclude with a summary of the main findings, showing how the analysis put forward yields an elegant syntactic account for the phenomena under discussion.

4.2 Indefinites in French and Spanish

Before presenting the ordering possibilities and possible scope relations within French and Spanish DPs, I should remind the reader that I adopt Bouchard’s (1998) perspective on the distinction between extensional and intensional adjectives (see also chapter 3). Recall that on this perspective, standard intersective adjectives are extensional in that they affect the set defined by the whole complex of interacting elements internal to N (*c*, *i*, *w* etc.), while a substantial number of intensional adjectives standardly taken to be incompatible with set intersection is reanalyzed as intersective with respect a subpart of the network of interacting elements of the N. For example, *future* affects the set of time interval *i*, and so on. Let me now return to the presentation of data in French and Spanish.

The position of most adjectives in French is post-nominal. But the so-called intensional adjectives, which assign properties to the sets of elements determined by subcomponents of N, appear mainly in pre-nominal position; this is not always the

case though. Another class of adjectives that appear pre-nominally contains the ones found under the term short -or descriptive- adjectives in descriptive grammars (see Olivier (1978) and L' Huiller (1999)) such as *petit* 'small', *grand* 'big', *jeune* 'young', *vieux* 'old', *long* 'long', *court* 'short', *bon* 'good', *mauvais* 'bad' and so on. Nevertheless, there are deviations in the position of the short adjectives; they can be post-nominal in idiomatic expressions or in contrastive contexts (e.g. *une petite femme/une femme petite* 'a small woman'). On the other hand, all adjectives that assign concrete properties, such as shape, colour or taste, and modify the noun as a whole are post-nominal. The position of some adjectives is variable. They can appear either pre-nominally or post-nominally. This usually has an effect on their meaning; that is, the adjective which occupies a pre-nominal position may have a meaning different from the same adjective when in post-nominal position. This is discussed later in this section.

Let me now turn to the ordering possibilities and the scope relations in indefinite DPs in French. I will use the same example as in Greek (see (96)), which contains an intensional adjective (*fausse*) and an extensional adjective (*dorée*). This will allow us to see how the above generalizations determine the default position of adjectives in French, which is quite rigid, and also how alternations in the position of adjectives affect the grammaticality of the corresponding phrase. So, in French we have:

- (99) a. * une fausse dorée montre
 a fake golden watch
- b. une fausse montre dorée
 a fake watch golden

- | | | | | | |
|----|---|----------|---------------|---------------|---------------|
| c. | ζ | une | montre | fausse | dorée |
| | | <i>a</i> | <i>watch</i> | <i>fake</i> | <i>golden</i> |
| d. | | une | montre | dorée | fausse |
| | | <i>a</i> | <i>watch</i> | <i>golden</i> | <i>fake</i> |
| e. | * | une | dorée | montre | fausse |
| | | <i>a</i> | <i>golden</i> | <i>watch</i> | <i>fake</i> |
| f. | * | une | dorée | fausse | montre |
| | | <i>a</i> | <i>golden</i> | <i>fake</i> | <i>watch</i> |

As (99) shows, only three out of the six possible orderings are attested. This is a major point of difference with Greek, where all six permutations of the elements are grammatical. The common point between these two languages is that they both allow post-nominal adjectives. The symbol ζ indicates potential marginality with respect to the scope relations among the elements of the phrase (see also (100)).

Let me now present the scope relations that hold inside the grammatical phrases of (99). This is illustrated in (100):

- (100)
- | | |
|------|-----------------------------|
| a. | [[une fausse montre] dorée] |
| a’. | [une fausse [montre dorée]] |
| ζ b. | [[une montre fausse] dorée] |
| c. | [[une montre dorée] fausse] |

The scope of the adjectives in the above French phrases is similar to their Greek counterparts (compare with (95)). More precisely, when both adjectives are post-nominal, the outer one takes scope over the inner constituent made up by the noun + adjective sequence (see (100b-c)). If one adjective precedes and the other follows the noun, as in (100a-a’), scope is ambiguous; intonation and pragmatic factors

determine which reading is the most salient. What is not covered in (100) is the case where we have two pre-nominal adjectives in a given DP, which Bouchard illustrates with the examples below:

- (101) a. [le faux [futur président]]
b. [le futur [faux président]]

The scope properties of the pre-nominal adjectives mirror those of the post-nominal adjectives. In other words, again the adjective which is closest to the noun forms a constituent with it and is modified by the furthest adjective. This is exactly parallel to what we found to be the case in Greek.

An interesting point concerning adjectival modification in French is that there are sometimes meaning differences between A-N and N-A combinations.

- (102) a. un pauvre homme = a pitiful man
b. un homme pauvre = a man who is not rich

In many cases the pre-nominal adjective yields ambiguity which is resolved if the same adjective appears post-nominally. The ambiguous phrase clearly has a strong and a weak interpretation according to native speakers' judgments. Consider the following example:

- (103) a. un grand homme = a great man (strong interpretation)
 = a tall man (weak interpretation)
b. un homme grand = a tall man (only the weak interpretation)

Bouchard (1997) says that in phrases like those in (102) and (103), when the adjective appears pre-nominally, its modification is restricted to the characteristic function *c* of the noun. By contrast, in the post-nominal construction a property is assigned to the set of individuals determined by the entire semantic network of the noun.

So, based on the data presented above, the generalizations that seem to emerge are the following: a) extensional adjectives follow the noun, b) intensional adjectives tend to precede (e.g. (102a)), c) some intensional adjectives may follow, however (e.g. (99d)). For a more detailed discussion of the data and a summary of Bouchard's analysis, see section 4.3.

Adjectives in Spanish, unlike English, but similarly to French can come either before or after the noun. More specifically, the vast majority of Spanish adjectives are normally placed post-nominally. A number of adjectives though may precede the noun. These are similar to French "short" adjectives and are found in descriptive grammars under the name descriptive -or common- adjectives (see Thompson, 1997). In this class, adjectives like *bueno* 'good', *malo* 'bad', *nuevo* 'new', *viejo* 'old', *grande* 'big' etc. are included. As in French, those adjectives may occupy a post-nominal position in contrastive contexts. Intensional adjectives in Spanish tend to precede the noun, but some can follow as well (see (104)). Indeed, the rules for adjective placement in French and Spanish are quite similar. In both languages, the normal position of most adjectives is after the noun, apart from a limited number of adjectives which occupy a pre-nominal position.

The question that arises at this point is whether Spanish DPs present the same word order variation as their French counterparts in indefinite DPs which contain

two adjectives. Again I will use the same example as in French and Greek, partly for reasons of consistency, but especially because the two adjectives are of different semantic origin (one intensional and one extensional). After that I will provide another example which includes two adjectives of the same semantic nature (both are extensional) but of different classification with regard to their default position.

- (104) a. * un falso dorado reloj
 a fake golden watch
- b. un falso reloj dorado
 a fake watch golden
- c. ζ un reloj falso dorado
 a watch fake golden
- d. un reloj dorado falso
 a watch golden fake
- e. * un dorado reloj falso
 a golden watch fake
- f. * un dorado falso reloj
 a golden fake watch

According to native speakers' intuitions, three out of the six possible combinations are grammatical. This fact is in total agreement with what we found for French. As in French, Spanish extensional adjectives are normally placed post-nominally; pre-nominal placement of the latter leads to ungrammaticality (compare for example (104a) with (104b)).

As might be expected, the scope relations are also the same as those we found in the corresponding French examples. This is illustrated in (105):

- (105) a. [[un falso reloj] dorado]
a'. [un falso [reloj dorado]]
b. [[un reloj falso] dorado]
c. [[une reloj dorado] falso]

Again, like in French and Greek, if the adjectives are on the same side of the noun (here post-nominally), the outer adjective modifies the constituent made up by the noun and the adjective which is immediately placed next to it. If one adjective precedes and the other follows the noun, scope is freer and two interpretive possibilities emerge (105a-a'). Thus, the scope relations in French (see (100), (101)), and Spanish (see (105)) are in line with those in Greek (see (95)).

4.3 Towards an analysis of Romance indefinite DPs

Bouchard (1997, 1998) suggests an analysis for French in order to explain the scope relations between the adjectives, the meaning differences between A-N and N-A sequences and some phonological effects among others. Let me discuss his account in some detail.

4.3.1 Bouchard's analysis

As we have seen, French adjectives may occupy either pre-nominal or post-nominal position depending on a number of factors. Bouchard's (1997, 1998) generalization is that intensional adjectives which assign specific properties to sets of elements

determined by subcomponents of the noun (like *c*, *w*, *i* etc.) must appear pre-nominally. Some examples are given in (106):

- (106) a. un supposé assassin
 an alleged murderer
 b. un ancien professeur
 a former professor
 c. un futur président
 a future president

By contrast, always according to Bouchard (1997), all the adjectives that modify the noun as a whole entity occur in post-nominal position. In this case, we have assignment of concrete properties to sets of elements determined by the noun itself, or, to put it differently, by the entire network of interacting elements in the entry of the noun. These properties, expressed by the corresponding adjectives, may refer to specifications of colour, shape, taste or to relations that differentiate one object from the other. For instance:

- (107) a. une voiture rouge (colour)
 a car red
 b. une table carré (shape)
 a table square
 c. une femme mariée (relation)
 a woman married

Nevertheless, there are some subjective and intensional adjectives that may appear on either side of the noun, with a meaning difference between the two combinations

(see also the discussion of meaning differences in §4.2). More specifically, Bouchard relies on the adjective “skillful”, among others, in order to develop this point.

- (108) a. un habile docteur
 a skillful doctor (as a doctor)
 b. un docteur habile
 a doctor skillful (for a doctor)

Pre-nominally the adjective *habile* ‘skillful’ affects a subcomponent internally to the noun, namely characteristic function, *c*. Here this creates the “as a” interpretation. In the post-nominal position, the same adjective denotes the “for a” interpretation, since it modifies the whole set of components of the noun. Notice that this claim goes contra Siegel (1980) who says that subsecutive adjectives like *skillful* occur with *as*-phrases, independently of their position. But, Bouchard (1997) maintains that such adjectives may be context-dependent, hence they may occur with *for*-phrases to indicate a comparison class. As he points out, the difference in meaning between the two uses is very subtle but can be brought out more clearly in appropriate contexts.

Suppose a group of friends get together to drive their cars, and the doctors of the company have been considered poor drivers in the past. If in this specific gathering doctor Michael is surprisingly good at driving, then this is the correct contextualization for someone to use (108b), but not (108a). This means that in this context doctor Michael is not skillful as a doctor (he may not be in fact), but the fact that he is a doctor is relevant. His skillfulness is determined by the whole semantic network of the noun *doctor*, its extension (specifically, Michael is in the intersection of doctors and skillful individuals).

On the other hand, consider a group of doctors, in which doctor Michael is exceptionally good at eye-operations, whereas all the others are poor at such operations. Under this perspective, it is plausible for someone to use (108a), but not (108b). In this context doctor Michael is skillful as a doctor, namely the fact that he is a doctor is not just relevant; it is the substance, the main fact the context refers to. In other words, his skillfulness is now determined by a subcomponent internally to the noun, namely the characteristic function c .

Bouchard also highlights the opposite case, in which a typical intersective adjective may exceptionally appear in pre-nominal position inducing a poetic effect, as in *tes lisses cheveux* ‘your sleek hair’. This adjective normally assigns concrete properties, which, as we saw, are characteristic of post-nominal modification. But in pre-nominal position the property of the adjective is added to a subcomponent of the noun. So, the person is not presented as merely having sleek hair, but as a person with a different type of object, “sleek hair”; it is defined as such.

Based on the above observations, Bouchard generalizes by saying that the N-A combination is a straightforward case of intersection between the set of elements that have the property of being an N with c , in w at i and the set determined by the adjective. On the other hand, the A-N combination takes place when the intended interpretation targets a modification of a subcomponent of the noun. This combination does not result in a saturated or modified functor category, since the combination is not with the noun as a functor category; rather it results in a complex functor category.

According to the basic assumptions of Integral Minimalism²⁴ which Bouchard (1997) adopts, the noun in the N+A combination projects since it is a functor category; by contrast, in the A+N combination, it is the complex functor category that projects. Along these lines, a simple NP consisting of a pre-nominal and a post-nominal AP (*bon père fier* ‘good proud father’) is as follows, where AN is an abbreviation for the complex functor category *bon père* (see Bouchard, 1997:39).

(109)

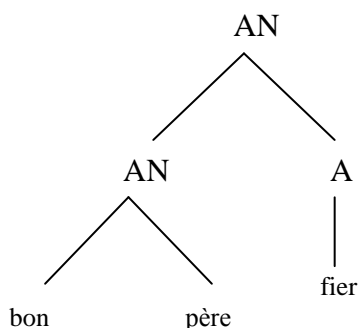

The above correlation between the adjective’s placement and its semantic nature is formalized by Bouchard’s following optimal parameter:

²⁴ The basic assumptions of Integral Minimalism are based onto Bouchard (1979, 1984, 1991, 1995, 1997), Chomsky (1994, 1995), Flynn (1983) and Speas (1986) are the following (adapted by Bouchard, 1997):

- (i) The only structural primitives are lexical items and an associative function Merge that combines them together.
- (ii) It follows from the underspecification of the operation Merge that the merger of α and β is licensed by selectional properties: if the complex expression resulting from the combination of α and β cannot be interpreted by the rules of the language, the result is gibberish (i.e., human languages combine meaningful elements into larger ones). Typically, one of α and β is a functor category which the other one saturates or modifies by assigning a property to it.
- (iii) Since the only primitives available are those taken from the lexicon, the result of Merging α and β is labelled α or β , not some additional label. (Here, though, I will mainly use standard syntactic labels like DP, NP, A, N etc. for convenience and coherence of the thesis).
- (iv) The functor category is the one that projects: the idea is that, even though a category X is slightly changed since it is saturated or modified by its sister category, it remains essentially an X.

- (110) ‘The functor category precedes its saturator or modifier in French. (i.e. the head precedes its complement or adjunct in French)’ (Bouchard, 1997: 42).

This parameter regulates the order between a noun and an intersective adjective; the adjective modifies the closed off functor category determiner by the noun as a whole, so the adjective must follow the noun. When the adjective is intensional, thus affects only a subcomponent of the noun, which is not a full closed off functor category, N may not precede the A according to (110). The correct order is derived by an application of the Elsewhere Condition, as Bouchard (1997, see there for further discussion) underlines. In that way, the structure in (109) is explained.

Bouchard offers two observations in support of his proposal. First, liaison is very frequent between an adjective and noun, but not between a noun and an adjective. In other words, liaison is present only between a pre-nominal adjective and a noun (see (111)). Second, many types of complex AP can only appear post-nominally, as in English, (see for example adjectives with complements, as in (112)).

- (111) a. Les (/z/) énormes (/z/) arbres
 the *enormous* *trees*
- b. Les (/z/) arbres (?/z/) énormes
 the *trees* *enormous*

- (112) a. Une chat [grosse comme un éléphant]
 a cat *big like an elephant*
- b. * Une [grosse comme un éléphant] chat
 a *big like an elephant* *cat*

Bouchard takes this as evidence that pre-nominal adjectives are merged lower in the tree than post-nominal adjectives. Indeed, he hypothesizes that modification of a subcomponent of a noun can only happen below the determiner. Thus, a tree with both pre-nominal (intensional or short) and post-nominal (extensional) adjectives, would be, for him, as follows:

(113)

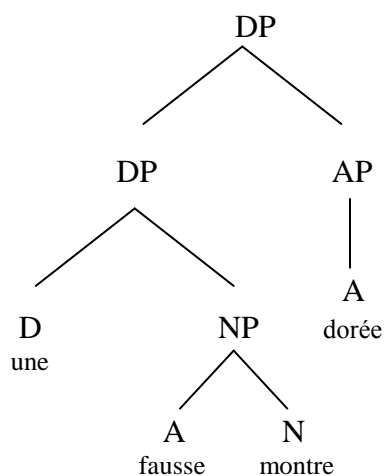

Thus, Bouchard's analysis implies that pre-nominal adjectives are closer to the noun than post-nominal ones. Here we face a paradox. According to the above structure the post-nominal adjective is expected to take scope over the pre-nominal one, since it c-commands it. But, as we have already seen, the scope of the adjectives in a sequence A-N-A is ambiguous, as any of the two adjectives may have scope over the other. This fact, which Bouchard accepts, seems to be problematic for his analysis and I will return to it later.

If we have a phrase with two pre-nominal adjectives, like *un futur faux président* 'a future false president', the structure that should be assigned, according to Bouchard's assumptions, is depicted in (114):

(114)

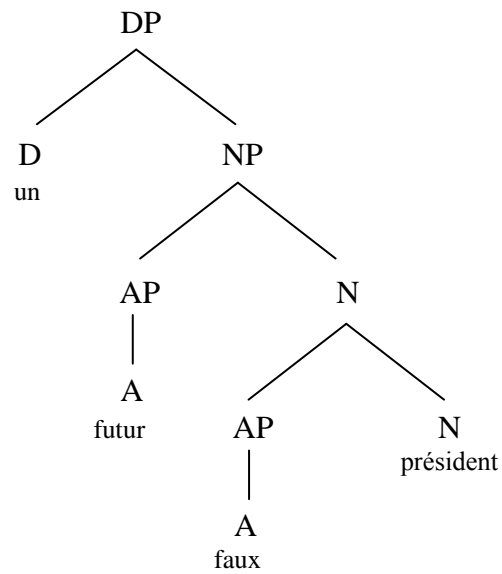

(Bouchard, 1997: 40)

The above structure remains the same in the case we interchange the position of adjectives, like for example, *un faux futur président*.

(115)

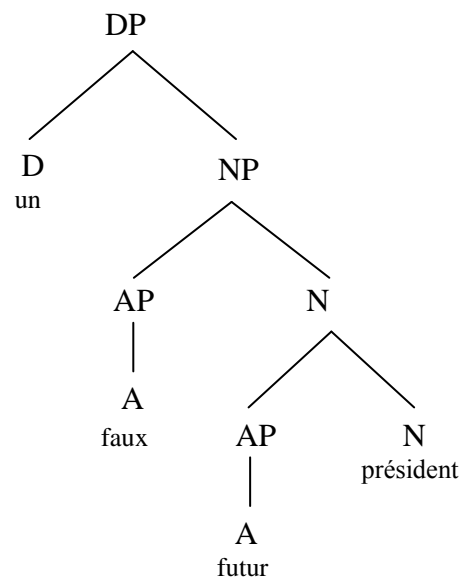

Again, in both (114) and (115), the outer adjective has scope over the inner phrase made up from the remaining adjective and the noun, this time in accordance with native speaker judgments.

If the two adjectives in an indefinite DP are post-nominal, like e.g. *une ligne parallèle colorée* ‘a line parallel coloured’, the structure assigned by Bouchard is illustrated in (116):

(116)

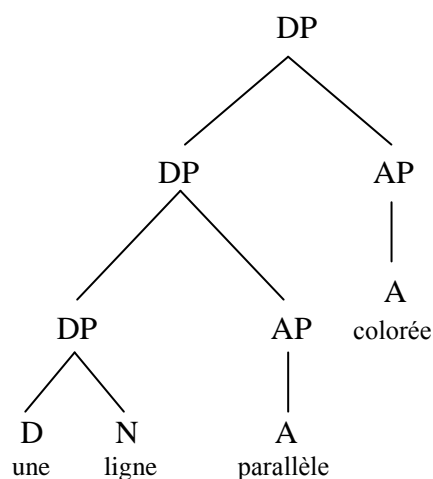

(see also Bouchard, 1997: 40)

The same holds in the case that the adjectives go the other way round, such as *une ligne colorée parallèle*. The structure, according to Bouchard, is the following:

(117)

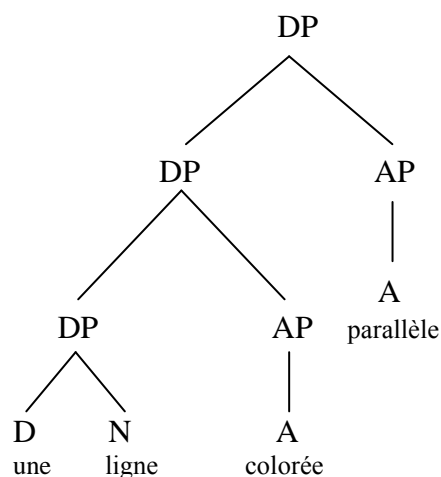

Scope relations in both the above structures are clear: the outer adjective in each case takes scope over the inner phrase. This correctly reflects native speaker judgments.

To sum up, from the above discussion it becomes clear that Bouchard's proposal is based on five central assumptions:

- (118)
- a. Intensional adjectives can be treated as instances of intersection. This means that such an adjective affects a subcomponent internal to N (e.g. *c*, *i*, or *w*, see chapter 3 §3.3.2 for more details).
 - b. Intensional adjectives are closer to the noun than the extensional ones. Specifically, intensional adjectives are generated below the determiner; by contrast extensional adjectives are generated above the determiner.
 - c. An adjective below the determiner can have scope over an adjective above the determiner, e.g. in an A-N-A ordering, through a special mechanism (see below for further discussion).

Moreover, there are two hidden assumptions contained in the Linearization Parameter (see (110)).

- d. Intensional adjectives are only found pre-nominally.
- e. Extensional adjectives are only placed post-nominally.

In spite of the fact that Bouchard’s account can capture all the possible serializations that are available in French, not all of the assumptions on which it rests appear equally tenable.

For instance, the assumption in (118b) that introduces the below D/above D distinction is problematic. As we have seen in section 4.2, the ordering $N A_{ext} A_{int}$ is attested in French, e.g. *une montre dorée fausse* ‘a watch golden fake’. In this DP the intensional adjective has scope over the extensional one, namely $A_{int} > A_{ext}$. This must therefore have a left-branching structure, as in (119):

(119)

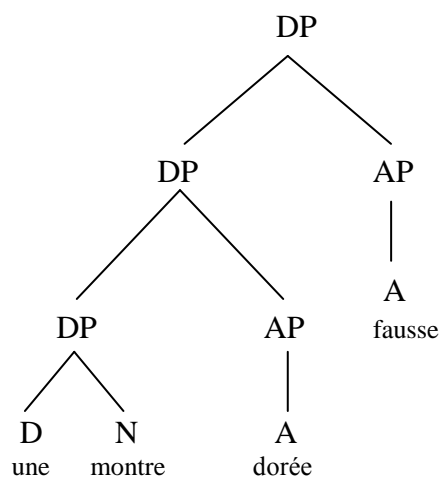

The aforementioned phrase could also be derived by leftward movement of $[N A_{ext}]$, across A_{int} but, as shown in the following tree, this would again lead to the

conclusion that A_{int} is attached externally to DP. Thus, this alternative should be excluded.

(120)

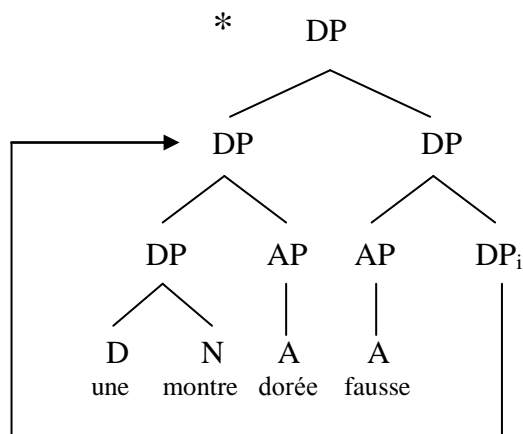

The structure in (119) is unexpected under Bouchard’s approach, as the post-nominal intensional adjective *fausse* must be generated above the determiner. We are therefore led to conclude that assumption (118b) is too strong.

Bouchard (1998) suggests that the adjective *faux* ‘fake, false’ can be analyzed as extensional if it occupies a post-nominal position (just like *skillful*). This implies that the adjective *faux* should always present meaning differences in the A-N/N-A sequences. The examples he uses are the following:

- (121)
- a. des pianos faux
pianos that are out of tune
 - b. des faux pianos
false (fake pianos)

So, Bouchard suggests that the pre-nominal adjective modifies possible world w , whereas the post-nominal one modifies the components of the N as a whole.

Although this may be correct for *faux* in (121)²⁵, it is not correct for (119). That (119) is not an isolated case is confirmed by the example below – among many others – (from a French book with the title “Répertoire universel et raisonné de jurisprudence” vol.12, Philippe Antoine Merlin, 1827: 121).

- (122) ... il savait nécessairement qu’ il faisait usage d’ un passeport faux, falsifié...
“he necessarily knew that he was using a fake (counterfeit), falsified passport.”

In this example the adjective *faux* clearly modifies the noun *passeport* intensionally: it modifies the possible world, yielding the interpretation a “fake passport”. Notably, this interpretation is further supported by the additional adjective *falsifié*.

In addition, it seems that we can have $A_{\text{int}} A_{\text{ext}} N$ in languages that allow extensional adjectives on the left of the noun, such as in English and Greek. If we take the example (i) *un habile docteur* (‘a skillful doctor’; *as*-reading) and (ii) *un docteur habile* (‘a skillful doctor’; *for*-reading), the structures that would be assigned to these cases on Bouchard’s theory are the following:

²⁵ Note that there are native speakers of French who disagree with the interpretation given in (121a). My informants mention that either pre-nominally or post-nominally, the adjective *faux* does not present any change in meaning in this context.

(123)

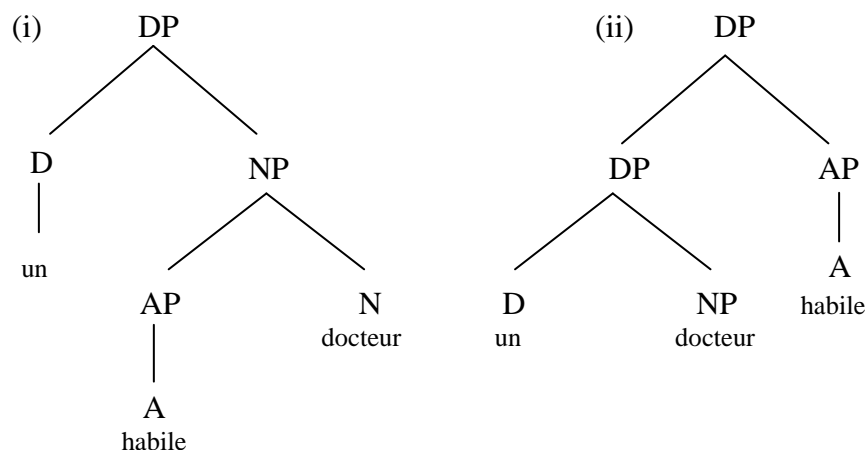

This analysis makes a clear prediction that I believe to be incorrect: subsective adjectives under the *as*-interpretation should always be attached lower than any truly intersective adjective. But, it seems that this is not the case. In English, for example, where there are no post-nominal adjectives, one would expect that no intersective adjective can intervene between the adjective *skillful* and the noun under the *as*-interpretation. But, the phrase “John is *a skillful young doctor*” is grammatical and permits the *as*-interpretation for the adjective *skillful*.²⁶

The above D/below D distinction is also problematic from the perspective of scope. In the structure depicted in (109), we see that the rightmost adjective takes scope over the inner phrase. But, as native speakers confirm, it is possible for the leftmost adjective to have scope over the constituent made up from the noun and the rightmost adjective. As already mentioned, this fact is recognized by Bouchard as well. In an attempt to solve this problem, Bouchard suggests that the pre-nominal adjective, being part of a complex head which includes the noun, could have scope over the post-nominal adjective just like the prepositional features of *aux* ‘to’ -

²⁶ A reading under the *for*-interpretation according to native speakers is possible too, but this is irrelevant to the point I am making here.

MASC-PL-DEF- can have ‘scope’ over its argumental complement. For instance, in the phrase *aux enfants* ‘to the children’, *aux* incorporates both the features of a preposition that has a DP argument and the features of D. In this way, the prepositional features of *aux* can select a DP that includes *enfants*. Analogously, the pre-nominal adjective *nouvelle*, in the DP *une nouvelle proposition intéressante* ‘a new interesting proposition’ or ‘an interesting new proposition’, being part of the complex head could have scope over the post-nominal adjective.

It seems that the notion of scope as used by Bouchard is quite vague. In particular, scope relations are not clearly reflected in the syntactic structures he assigns. For this reason, he is obliged to introduce the portmanteau mechanism described above. Clearly, such a mechanism becomes redundant if scope relations are properly expressed in the first place. More to the point, since (118b) has been shown to be too strong, (118c), together with the Bouchard’s special scope mechanism, can be dispensed with. Finally, the above discussion has also shown (118d) to be incorrect, as at least some intensional adjectives can be found post-nominally after all. Thus, only (118a) and (118e), repeated here, seem well-motivated.

- (118) a. Intensional adjectives can be treated as instances of intersection. This means that such an adjective affects a subcomponent internal to N (e.g. *c*, *i*, or *w*, see §3.3.2 for more details).
- e. Extensional adjectives are only placed post-nominally.

4.3.2 An alternative analysis

In section 4.2, we have seen that French and Spanish present the same ordering possibilities in indefinites with two adjectives of different semantic nature (one clearly intersective/extensional and one intensional) plus a noun. In this section, I discuss how these data can be captured adequately by a syntactic account.

I repeat here the grammatical strings and the scope relations within them, both in French and Spanish:

French

- (124) a. [[une fausse montre] dorée]
 a fake watch golden
 a'. [une fausse [montre dorée]]
 a fake watch golden
 _i b. [[une montre fausse] dorée]
 a watch fake golden
 c. [[une montre dorée] fausse]
 a watch golden fake

Spanish

- (125) a. [[un falso reloj] dorado]
 a fake watch golden
 a'. [un falso [reloj dorado]]
 a fake watch golden
 _i b. [[un reloj falso] dorado]
 a watch fake golden
 c. [[un reloj dorado] falso]
 a watch golden fake

Bouchard's claim that post-nominal adjectives, which are above D, are intersective echoes other proposals, such as that of Sproat & Shih (1991), suggesting that such adjectives are in fact reduced relatives. However, as shown in (124) and (125), at least some intensional adjectives can also appear post-nominally. Furthermore, post-nominal adjectives in French and Spanish do not need to have a restrictive reading, which would be surprising if they were reduced relatives. For example in French the adjective *vénéneux* 'poisonous' is post-nominal, but a phrase like the following would be odd, because cobras are always poisonous:

(126) ??A cobra that is poisonous is in my garden.

I conclude from this that French and Spanish truly have post-nominal adjectives and assume Bouchard's (118e) to regulate the relative order between A and N in French and Spanish.

On a restrictive reading of the post-nominal adjective, the phrase *une fausse montre dorée*, on the scopal interpretation in (124a), should be assigned the structure in (127):

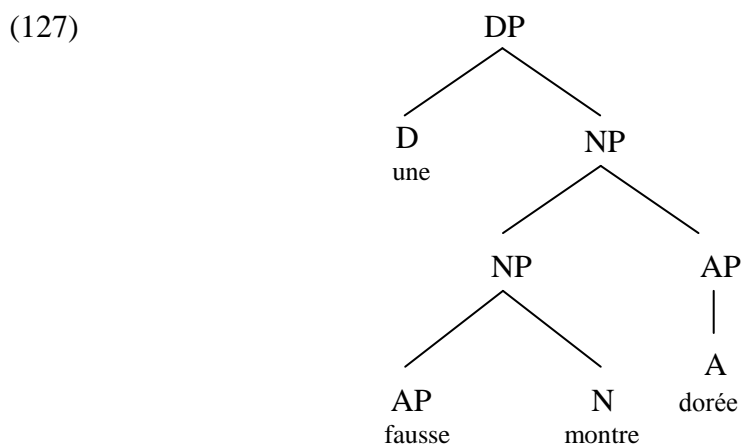

It would also be possible for the post-nominal adjective *dorée* to be attached above the determiner, as shown in (128), but it seems that such a structure should be ruled out.

(128)

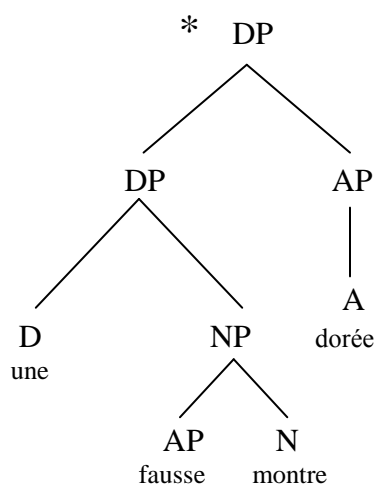

Bouchard suggests that all adjectives found post-nominally should be analyzed under the extensional view and thus, they should be attached above D. This means that they are clear instances of intersection. We have already seen though that post-nominal adjectives have to be neither intersective nor restrictive. But of course they *can* be intersective and restrictive. So, what could rule out an above-D attachment of the adjective for those cases?

It is known that a pre-nominal adjective can take scope over a restrictive, intersective post-nominal adjective (see (124a')). Since the pre-nominal adjective is clearly below D, it would follow that the post-nominal one must be below D as well. But if it is below D on that reading, there seems to be no reason to assume that it

would be above D on the scope in (127). For this reason the structure in (128) is considered ill-formed.

As shown earlier, the opposite scope relations are also possible (see (124a')) for an A-N-A sequence. This is depicted in (129):

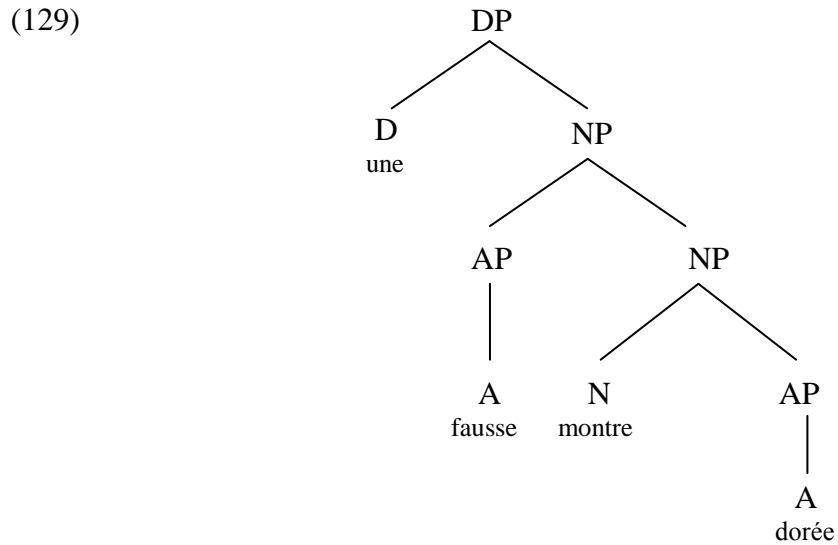

Recall that the scope relation depicted in the above structure constituted a problem for Bouchard's account.

Let us now see what happens with multiple post-nominal adjectives. The structure that is assigned for the phrase in (124b) is given in (130):

(130)

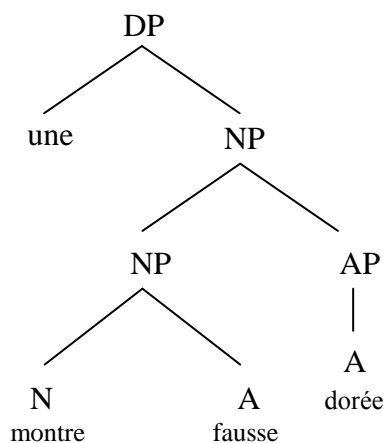

Similarly, the structure for (124c) is illustrated in (131):

(131)

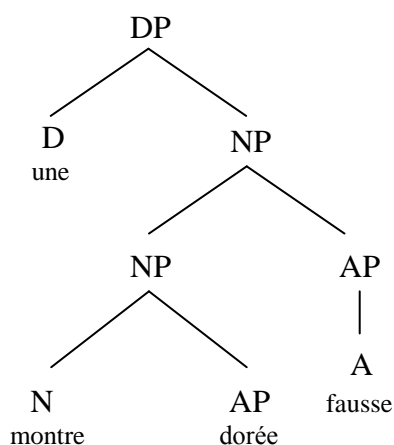

Note that the same ordering possibilities are also available for definite DPs in French and Spanish. So, according to the analysis presented here, there exists a certain degree of flexibility below the determiner in French and Spanish.

The assumption that the adjectives in these two Romance languages can be base-generated on either side of the noun, along with the fact that they exhibit flexibility below the determiner, suffices to capture the ordering possibilities they display.

At this stage, we have arrived at an analysis of adjectival modification in French and Spanish that is sufficiently sophisticated for our primary objective, which is to see to what extent Greek indefinites could yield to a comparable analysis.

4.4 Back to Greek: Indefinite DPs

We started this chapter with two observations: (i) Greek indefinites allow post-nominal adjectives, much like Greek polydefinites, but without any visible indication of determiner spreading; (ii) post-nominal adjectives in the absence of DS are also found in other languages, such as those in the Romance language family. We are now ready to turn to the question whether the syntax of adjectival modification in Greek indefinites might be similar to that of adjectival modification in French and Spanish DPs or whether an altogether different analysis is called for.

If Greek indefinites are like French indefinites, they would exhibit the kind of ‘flexibility’ below the indefinite determiner that is clearly absent in Greek monadic definites. An alternative one could explore is to attempt an analysis of Greek indefinites on a par with that proposed for definites. On this view, Greek indefinites would optionally exhibit hidden spreading of the indefinite determiner. In this section I discuss these alternatives in detail.

If Greek indefinites are like French indefinites, then we might expect (i) that extensional adjectives appear only on the right side of the noun and (ii) that post-nominal adjectives need not be restrictive. However, neither of these expectations is borne out: extensional adjectives can appear on either side of the noun: *ena chrisso*

roloi ‘a golden watch’ – *ena roloi chrisso* ‘a watch golden’, while post-nominal adjectives always have a restrictive reading. Consider the following example:

- (132) a. Ti agorases?
 What you-bought?
 “What did you buy?”
- ?? Agorasa ena aftokinito mikro.
 I-bought a car small
 “‘I bought a small car.’”
- b. Ti agorases? ena megalo aftokinito?
 What you-bought? a big car?
 “‘What did you buy? A big car?’”
- Ohi! Agorasa ena aftokinito mikro telika
 No! I-bought a car small finally
 “‘No! I bought a small car finally.’”

As the above example shows, post-nominal adjectives in indefinite DPs appear to be felicitous in contrastive contexts, as in (132b), where they yield a restrictive reading. Such an interpretation is not easily accessible in (132a), where it requires a certain amount of ‘accommodation’ (namely the presupposition that the speaker was planning to buy a medium-size or large car); this is the reason why the existence of a post-nominal adjective in this case makes the phrase odd.

There are two more reasons why analyzing Greek indefinites like Romance indefinites would be unwise. First of all, the ordering possibilities in Greek are freer than in French and Spanish, because there are no restrictions whatsoever regarding the position of adjectives. Second, indefinite DPs in Romance present exactly the same reordering possibilities as definite DPs. The situation is different in Greek. The

different permutations and the free word order observed in indefinites are not the same as in monadic definite DPs, but as in polydefinite DPs. For instance, Greek definites do not allow post-nominal adjectives, whereas this is permitted in indefinites and polydefinites:

- (133) a. to pseftiko chrisso roloi DEFINITE
 the fake golden watch
- b. * to roloi chrisso pseftiko DEFINITE
 the watch golden fake
- c. to roloi to chrisso to pseftiko POLYDEFINITE
 the watch the golden the fake
- d. ena roloi chrisso pseftiko INDEFINITE
 a watch golden fake

Finally, in Greek definite DPs adjective placement below the determiner is completely fixed. All adjectives precede the noun. All order freedom is associated with determiner spreading. It would therefore be downright problematical to say that for Greek *indefinites* adjective placement below D is free.

Let us now consider the alternative hypothesis, which treats Greek indefinites on a par with Greek definites. On this view, indefinites in Greek present properties of both monadics and polydefinites, as outlined below:

- (134) a. Indefinite determiner spreading is obligatory for post-nominal adjectives, yielding an obligatory restrictive reading.
- b. Indefinite determiner spreading is optional for pre-nominal adjectives; this means that both the restrictive and the non-restrictive readings are

available.

- c. The sequence ‘*ena* A A \emptyset_N ’ is possible if and only if these adjectives are restrictive.

This approach correctly predicts that an adjective on the left of the noun can be non-restrictive, while an adjective to the right of the noun has an obligatorily restrictive reading. We also expect, correctly, that extensional adjectives can occur on either side of the noun, just as with definites.

There is just one rather obvious problem with this proposal: there appears to be no evidence that the indefinite determiner *ena* ‘a(n)’ can indeed spread. We should therefore explore the possibility that the claim that *ena* is the indefinite determiner is wrong.

4.4.1 Indefinite determiner or quantifier?

In fact, it has already been proposed in the literature that *ena* is not a determiner but a quantifier (see Kariaeva, 2004a-b and Alexiadou, 2006). *Ena* presents the same distribution as the quantifiers *kathe* ‘every’ and *kapjos* ‘some’. These also disallow spreading and can partake in constructions which involve adjectival modification, where the adjective can be found either pre-nominally or post-nominally. Consider the following examples:

- (135) a. *kathe* *pseftiko* *roloi*
 every *fake* *watch*
- b. *kathe* *roloi* *pseftiko*
 every *watch* *fake*

- c. * kathe pseftiko kathe roloi
every fake every watch
- (136) a. kapjo pseftiko roloi
some fake watch
- b. kapjo roloi pseftiko
some watch fake
- c. * kapjo pseftiko kapjo roloi
some fake some watch
- (137) a. ena pseftiko roloi
a fake watch
- b. ena roloi pseftiko
a watch fake
- c. * ena pseftiko ena roloi
a fake a watch

Notice that *ena* and *kapjo* can substitute for each other in many contexts without change in meaning. Because *ena* is not realized in the plural, *kapjo* can be used in such cases as well.

Interestingly, the use of *ena* in Greek is optional in any context. This behaviour can be considered an indication that the indefinite determiner in Greek is in fact null. For instance, examples like the following are totally grammatical:

- (138) Thelo na agoraso aftokinito megalo
I-want to buy car big

(138) is considered equivalent in meaning with (139):

- (139) Thelo na agoraso ena aftokinito megalo
I-want to buy a car big

In addition, *ena* ‘a(n)’ can be used as a numeral meaning “one”, even in polydefinite DPs, such as in (140):

- (140) a. to ena to pseftiko to roloi
the one the fake the watch
 b. to roloi to ena to pseftiko
the roloi the one the fake

But without a preceding definite determiner the numeral *ena* can appear only in the left-most position of the DP and nowhere else:

- (141) a. ena pseftiko roloi
one fake watch
 b. * roloi ena pseftiko
watch one fake

4.4.2 Polyindefinites

Given the hypothesis that indefinites with post-nominal adjectives involve DS, taking into account (134), along with the claims that *ena* is in fact a quantifier rather than a determiner and that the indefinite determiner in Greek is null, allows us to maintain that the order freedom in indefinites is associated with a hidden pattern of indefinite determiner spreading. This can be supported empirically by the interpretive properties correlated with post-nominal adjectives.

It is already known (see also Kolliakou 2004, for further discussion) that determiner spreading in definites triggers an obligatory restrictive reading on affected adjectives. DS in definites is obligatory post-nominally and therefore post-nominal adjectives in definites are always interpreted restrictively. The hypothesis that order freedom in the Greek DP is dependent on determiner spreading therefore makes the prediction that post-nominal adjectives in indefinites must have a restrictive reading.

Consider the following example (recall also (132)):

- (142) a. *Fr.* Qu'est-ce que tu as vu au jardin? -Un cobra vénéneux.
 What did you see in-the garden? -A cobra poisonous.
- b. *Gr.* ??Ti ides ston kipo -Mia cobra dilitiriodi
 What did you see in-the garden? -A cobra poisonous.

It is known that all cobras are poisonous. So, the adjective *dilitiriodis* 'poisonous' cannot have a restrictive reading. This is the reason why the Greek phrase *mia cobra dilitiriodi* is pragmatically odd. By contrast, if the same adjective occupies a pre-nominal position, the resulting phrase is fine.

For all the above reasons, I assume that post-nominal adjectives (along with the noun) in Greek indefinite DPs are all preceded by a null determiner:

- (143) a. (#) ena Ø roloi Ø pseftiko Ø chrisso
 a watch fake golden
- b. ena Ø roloi Ø chrisso Ø pseftiko
 a watch golden fake

Of course, this proposal can be generalized to pre-nominal adjectives in which spreading is optional, according to (134b) of my hypothesis.

- (144) a. (#) ena Ø chrisso Ø pseftiko Ø roloi
 a *golden* *fake* *watch*
- b. ena Ø pseftiko Ø chrisso Ø roloi
 a *fake* *golden* *watch*
- c. ena Ø chrisso Ø roloi Ø pseftiko
 a *golden* *watch* *fake*
- d. ena Ø pseftiko Ø roloi Ø chrisso
 a *fake* *watch* *golden*

The quantifier *ena* is realized only once, in the initial position of any given DP. The slots before each element of a given phrase are occupied by null determiners.

This structure of course parallels that of polydefinites. For instance, the structure assigned to the phrase *ena pseftiko chrisso roloi* ‘a fake golden watch’, when the contextualization requires a restrictive reading is illustrated below:

(145)

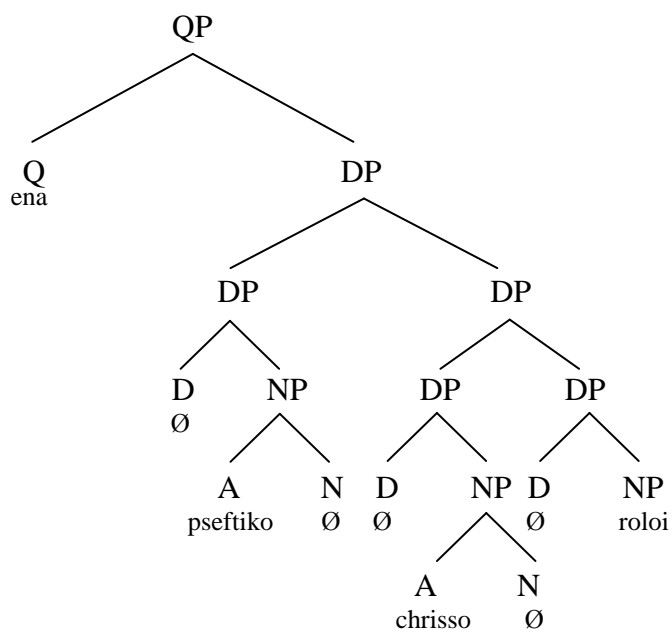

If a non-restrictive reading is required then the indefinite DP with pre-nominal adjectives is assigned a structure similar to monadics:

(146)

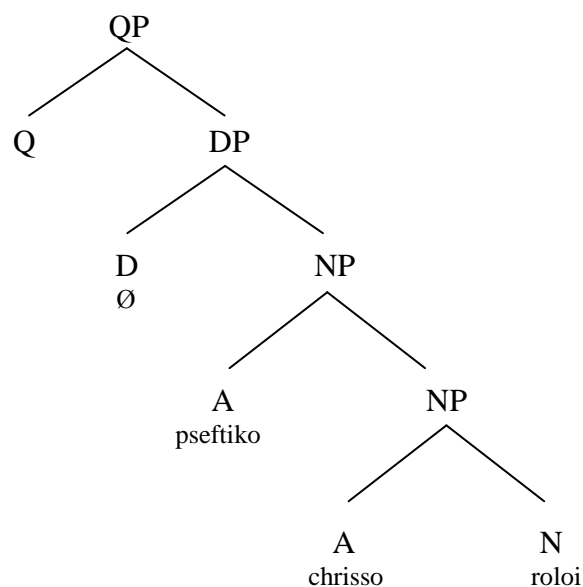

We need to mention that under a restrictive reading, an indefinite of the type *ena A N* has two possible analyses: one involving a polyindefinite, and a monadic

analysis. The above proposal predicts that both a restrictive and a non-restrictive reading are available pre-nominally, as already mentioned (134b).

The hypothesis advanced above also predicts that strings of the form *ena A A Ø_N* are possible if and only if both adjectives are restrictive. That this prediction is correct is demonstrated by the following piece of evidence. As mentioned in chapter 2, a definite DP with an elided noun cannot contain more than one adjective. Hence, if more than one adjective is to be used, determiner spreading is obligatory or the phrase becomes ungrammatical. On the other hand, an indefinite DP with an elided noun permits the appearance of more than one adjective. To make this clearer, let me give the appropriate context. George asks Mary to give him *to/ena megalo kokino vivlio* ‘the/a big red book’. There are many books in the room and Mary does not hear him well, so the following dialogue takes place:

- (147) a. M: Pjo vivlio?
 which book?
 G: * to megalo kokino Ø_N DEFINITE
 the big red
 G: to megalo to kokino Ø_N POLYDEFINITE
 the big the red
- b. M: Ti vivlio?
 what book?
 G: ena Ø megalo Ø kokino Ø_N INDEFINITE
 a big red

Interestingly, both adjectives can only get a restrictive reading (here they narrow down the set of books that Mary probably has in her mind). We can see this in a

different example, with a context that requires a non-restrictive reading for one of the adjectives:

- (148) Q: Ehis di tin kobra tou Yanni?
 “Have you seen John’s cobra?”
 A: ??Nai, mia megali dilitiriodi.
 “Yes, a big poisonous.”

The answer in (148) is odd, because it yields a restrictive reading which does not make sense, since all cobras are poisonous.

Taken together, the patterns in (147) and (148) add considerable weight to the hypothesis that DS may also apply in indefinites and therefore to the claim that Greek also has *polyindefinites*. It appears that instances of adjectival modification in Greek indefinites present a syntactic variation which is much closer to *polydefinites* rather than to *definites*.

As we have seen, the structure of an indefinite with pre-nominal adjectives can be parallel either to the structure of a *polydefinite* or that of a *monadic*, with the expected consequences for the available readings. Taking into account the discussion in chapter 3 on markedness effects, it is predicted that the semantic hierarchy of adjectives loosens when a restrictive reading, and hence a *polyindefinite* structure, is required. On the other hand, when a non-restrictive reading is forced, it is predicted that a *polyindefinite* structure is not licensed and hence that markedness effects will be stronger. It is quite hard though for native speakers to see this difference intuitively, because these two instances are homophonous after all. Perhaps the

difference is clearer in a contextualization with noun elision. Let us investigate this case in a dialogue, where Mary and George discuss their shopping:

- (149) a. M: Ti thes na sou agoraso?
 “What do you want me to buy for you?”
 G1: ena megalo kokino vivlio
 a big red book
 G2: ? ena kokino megalo vivlio
 a red big book
- b. M: Thelis na su agoraso ena mikro kokino vivlio
 “Do you want me to buy a small red book for you?”
 G1: Ohi, thelo ena megalo kitrino...
 No, I-want a big yellow...
 G2: Ohi, thelo ena kitrino megalo...
 No, I-want a yellow big...

As shown in (147), the two adjectives contextually followed by an elided noun can only get a restrictive interpretation, thus a structure like (145) should be assigned. In (149b), we indeed see that an interchange between the adjectives is possible without giving rise to strong markedness effects, since both G1 and G2 phrases are felicitous. By contrast, in (149a), the George’s second answer seems rather unnatural, thus marked, because it deviates from the neutral ordering of adjectives in a single, non-restrictive, indefinite DP. It can only be accepted if the hearer ‘accommodates’ an intended contrast on the part of the speaker, in which case a polyindefinite structure would be licensed.

4.5 Concluding remarks

In this chapter I have argued that the ordering differences in Romance and Greek do not have the same source. In Romance, the adjective can be generated on either side of the noun. But, the position of adjectives is quite rigid (some can occur pre-nominally, while some others can appear only in post-nominal position); this results in fewer, or more restricted ordering possibilities in comparison with Greek.

Exactly the opposite holds for Greek. Here we can swap DPs without any restrictions. This results in many more available orderings. In fact, Greek exhibits all the six possible alternations in any polydefinite DP made up from two adjectives and a noun. The absence of order freedom in Greek monadic DPs suggests that there is no flexibility below the determiner in this language and in itself provides a strong argument for the analysis of indefinites advanced here which postulates hidden determiner spreading in Greek indefinites.

In spite of the considerable empirical reasons for the existence of polyindefinites, my proposal could be confronted with the following objection. The structure I have assigned to polydefinites is the same as that for instances of close apposition, motivated in part by a number of core properties that are common to both constructions. As we have seen above, the structure assigned to polyindefinites is identical to that of polydefinites. But, polyindefinites are generally believed to be incompatible with apposition. In other words, as noted in section 1, there are no appositive structures involving an indefinite. Apposition requires two definite DPs.

There are several potential responses to this objection, one of which would simply characterize the similarities between polydefinites and appositives as purely

accidental. However, more progress may be possible if we consider that the link between these constructions reduces to the interpretive rule of complex argument formation they share. It is, after all, not that strange for a particular interpretive rule to be involved in a variety of syntactic constructions. Consider, for example predication. Its default syntactic manifestation holds between the subject and the predicate of a clause. But predication is also widely credited as the interpretive mechanism linking a relative clause to its head. It is also arguably crucial to the integration of a variety of parentheticals into their syntactic host, and so on. I would therefore submit that it remains to be seen whether the claim that polydefinites, polyindefinites and appositives all include complex argument formation is truly problematic.

To recapitulate, this chapter shows that analyzing Greek indefinites on a par with Romance indefinites is unwise, because of differences in ordering possibilities and the obligatory restrictiveness of post-nominal adjectives in Greek. I proposed that instead Greek indefinites be analyzed similarly to Greek polydefinites. Having argued that the indefinite *ena* is in fact a quantifier, I suggested that the Greek indefinite determiner is null and that Greek indefinites may therefore exhibit hidden determiner spreading. This account offers a unified analysis of polydefinites and indefinites in Greek, which display the same word order freedom and the same characteristic interpretive properties.

CHAPTER 5

Persian Ezafe and Greek Polydefinites

5.1 Introduction

This chapter is concerned with the investigation of any possible correlation between the Greek polydefinite and the Modern Persian Ezafe constructions. In particular, I will try to determine whether the Greek polydefinite construction can be analyzed on a par with the Ezafe construction (as proposed by e.g. Larson & Yamakido, 2008 support).

The Ezafe particle is a linking element that appears in a number of Iranian languages²⁷ in which the nominal modifier generally follows the noun (the word order pattern within the NP is strongly head initial on the surface). A large class of nominal modifiers, like adjectives, the possessor NPs, some PPs, but not relative clauses (unless reduced) require Ezafe as a linker. In Modern Persian (Farsi), this linker is realized as the particle -(y)e.

The term Ezafe is interesting. It comes from the Arabic word *idafat* ‘addition, adjunction’, as Samvelian (2007) reports. Also, Den Dikken & Singhapreecha (2004) say that Ezafe means “putting things together” or “linking things”. It has been claimed in the literature that the origins of the particle in Modern Persian can be traced back to the Old Persian relative pronoun/demonstrative *hya* (*hyâ*, *tya*) (see Kent 1944, Haider & Zwazinger 1981, among others), which was used to introduce relative clauses and sometimes attributive adjectives and the possessor NP.

²⁷ Persian is not the only language exhibiting the Ezafe construction. It can be also found in Hawrami (a Kurdish / Northwestern Iranian language, known as Izafe too) and in other Kurdish dialects, like Kurmanji and Sorani and in Zazaki. In general, Ezafe is a feature of a number of Iranian languages. Henceforth, in this chapter, with the term Ezafe, I will mainly refer to Persian, unless otherwise stated.

According to Samvelian (2007), a typical Persian NP has the following schematic structure, where each modifier is linked to the preceding constituent by Ezafe:

- (150) (Det) N-Ez AP-Ez PP-Ez NP(Poss)
in ketâb-e kohne-ye bi arzeš-e Maryam
this book-EZ ancient-EZ without value-EZ Maryam
‘‘This ancient worthless book of Maryam’s’’

The Ezafe construction has received considerable attention since Samiiian (1983) pointed out some of its puzzling properties. This has given rise to a number of competing accounts (see among others Samiiian 1983, 1994, Ghomeshi, 1997, Kahnemuyipour, 2000, Holmberg & Odden, 2005, Larson & Yamakido, 2008, Samvelian, 2007).

Most of the aforementioned authors are exclusively concerned with the Ezafe construction. On the other hand, Larson & Yamakido (2008) try to relate the phenomenon to polydefiniteness and propose a unified account for both. The main reason for pursuing such a unified analysis is that post-nominal adjectives in Greek definite DPs are allowed if and only if the definite determiner is multiply realized between each of the modifiers. This is similar to the Ezafe construction, in which post-nominal adjectives must be linked to the noun with the Ezafe particle²⁸. This attempt at unification and the wider question whether polydefinites and structures exhibiting Ezafe should be analyzed along the same lines will be our main concern here.

²⁸ Of course, this is not the only reason why Larson & Yamakido (2008) proposed a unified account for both Ezafe and Greek polydefinite constructions. For detailed discussion see sections 5.3 and 5.4.

The chapter is organized as follows. In section 5.2, I present in detail the basic facts about Ezafe, discussing its status, its use and its peculiarities through a range of examples. This section is also devoted to a survey of the major proposals concerning the status of Ezafe. Samiian (1983, 1994) has presented a very detailed contribution on the topic. The data and empirical generalizations in these two studies have influenced much of the subsequent work. She basically suggests (see Samiian, 1994) that Ezafe is a case-marker, inserted to case-license [+N] elements. According to Ghomeshi's (1997) analysis which is based on Samiian's data, Ezafe never attaches to phrasal categories. She claims that nouns in Persian are unable to give rise to maximal projections. Larson & Yamakido (2005) follow Samiian in taking Ezafe to be a case-marker but develop this idea in a rather different way. Samvelian (2007) argues that Ezafe is best regarded as an affix which indicates a dependency between the head noun and a dependent (a modifier or a possessor NP). Finally, I will present Ruff's (2008) proposal, according to which Ezafe is a linker that forms a constituent with the dependent, arguing that this account seems to be on the right track.

In the third section (5.3), I will present Larson & Yamakido's view on Greek polydefinites and I will discuss how they combine it with the Ezafe construction. I will try to show that their approach faces some serious empirical and conceptual problems, and as a consequence their proposal must be rejected. Moreover, this section contains an extended discussion on why the Ezafe and the Greek polydefinite constructions should not be unified. It appears that the two phenomena, despite some similarities, present many more major differences that show that they cannot be two

sides of the same coin. Section 5.4 concludes the chapter with an overview and some final remarks.

5.2 The Ezafe construction: an overview of the basic facts and accounts

Persian and other Western Iranian languages display two different patterns as far as word order within the NP is concerned, head initial or head final. The first pattern is characteristic of the Ezafe construction. But, the most common pattern within the NP is the head-final one. For comparison, (151) illustrates an average NP in Urdu, which is a language that exhibits Ezafe and similar NP patterns to Persian:

- (151) eek laal gaarii
one red car
 “one/a red car” *Adapted from Bögel et al. (2008)*

Persian contains pre-nominal numerals and demonstratives. Moreover, superlatives seem to be the only case of pre-nominal adjectives. Ezafe never appears in the pre-nominal position (see (152)).

- (152) a. in(*-e) otâq
this(-EZ) room
 “this room”
 b. kûechektarin(*-e) ketâb
smallest(-EZ) book
 “the smallest book”

As shown by (153), the Ezafe introduces different kinds of modifiers, except (153e) where it introduces a complement. The construction is recursive; the existence of multiple modifiers triggers multiple realization of Ezafe (see e.g. (153b), (153f)).

As already mentioned, relative clause modifiers, in spite of the fact that they are post-nominal do not trigger Ezafe. These are introduced by a relative morpheme (-î) which may be historically related to Ezafe, but is now considered distinct by Persian grammarians.

- (154) manzel- î(*-e) ké sabz ast
house-REL that green is
“house that is green”

Likewise, prepositional arguments of the head noun are merely juxtaposed to it. This is also true when the noun is followed by modifying elements; prepositional arguments are placed outside the Ezafe domain. This is illustrated in (155):

- (155) a. bahs(*-e) bâ john
discussion(-EZ) with John
“discussion with John”
b. bahs-e diruz-e maryam(*-e) bâ john
discussion-EZ yesterday-EZ Maryam(-EZ) with John
“Maryam’s yesterday discussion with John”

5.2.1 Samiian (1994)

The main claim of Samiian’s (1994) study is that Persian Ezafe is a dummy case-assigner licensing the complement of [+N] categories, including nouns, adjectives and some prepositions. Samiian supports this claim, showing that Ezafe is not only

used for reasons of modification, but also in contexts where English would analogously use the genitive case-marking preposition *of*, namely with complements of N, complements of APs and some partitives, as exemplified below (adapted from Samiian, 1994 and Larson & Yamakido, 2005). Based on these examples, Samiian (1994) maintains that Ezafe plays a role very similar to the English *of*; that is, to case-mark the complement that follow nouns, adjectives and partitives.

- (156) Complements of N
- a. hordan-é âb
drinking-EZ water
 “drinking of water”
- b. forushandé-yé ketâb
seller-EZ books
 “seller of books”
- (157) Complements of A
- a. asheq-é Hæscæn
in love-EZ Hasan
 “in love with Hasan”
- b. negæran-é bæche
worried-EZ child.PL
 “worried about the children”
- (158) Partitives
- hardo- yé-în manzelhâ
both-EZ-DEF houses
 “both (of) the houses”

Samiian (1994) uses another piece of evidence to support the case-assignment hypothesis. This refers to the behaviour of prepositions with regard to Ezafe. Schematically, Samiian divides prepositions in two categories: the first (Class 1) rejects Ezafe and the second (Class 2) either permits or requires Ezafe (I will refer to the latter as Class 3). Thus, the category P is not uniform in Persian. Since prepositions are typically analyzed as (-N, -V), one might expect that PP in general would not be compatible with Ezafe marking. But, according to Samiian and as shown in (153), some Ps allow the attachment of Ezafe. Consider the following examples, which demonstrate the differences between the classes of prepositions in Persian²⁹:

(159) Class 1 of Ps (no Ezafe)

- a. be (*-ye) Hæscæn
to (-EZ) Hasan
“to Hasan”
- b. ba (*-ye) Hæscæn
with (-EZ) Hasan
“with Hasan”

(160) Class 2 of Ps (allow Ezafe)

- a. zir(-e) miz
under (-EZ) table
“under the table”

²⁹ The examples in (159), (160) and (161) do not contain all the prepositions that correspond to each case, but a subset indicative of their function. For more details see Samiian (1994) and Larson & Yamakido (2005).

- b. ru(-ye) deræxt
on (-EZ) tree
 “on the tree”

(161) Class 3 of Ps (require Ezafe)

- a. dor-e xane
around (-EZ) house
 “around the house”
- b. beyn-e mœn-o to
between(-EZ) me-and you
 “between you and me”

Samiian says that in fact only Class 1 prepositions are true function words equivalent to English Ps in that they require an object. On the other hand, Class 2 Ps can be realized after determiners and can even have plural morphology. PPs headed by Class 2 prepositions appear in case positions and are joined to nominals by Ezafe.

- (162) a. rœft ba *(Hœscœn)
went with Hasan
 “went with Hasan”
- b. in ru
this top
 “up here”
- c. œks-e ru-ye miz
picture-EZ on-EZ table
 “picture on the table”

Adapted from Larson & Yamakido (2005)

Based on the aforementioned data Samiiian presumes that Class 2 prepositions are [+N], they are noun-like. This is the reason they trigger Ezafe: they are not expected to assign case.

5.2.2 Ghomeshi (1997a, b)

Ghomeshi³⁰ claims that Ezafe never attaches to phrasal categories. This basic hypothesis relies on another one, according to which Persian nominals (nouns, adjectives etc.) do not project. This means that nouns never appear with specifier and complement positions. In addition, the NP node cannot dominate any phrasal material. It should be noted that in Ghomeshi's account, despite the fact that Persian nouns are non-projecting, they still appear as NP when selected by a projecting head (e.g. D⁰). Thus, Ghomeshi assigns the following structure to the Ezafe construction (notice that possessors are always DPs):

³⁰ Ghomeshi's proposal basically relies on Samiiian's (1983) data.

(163)

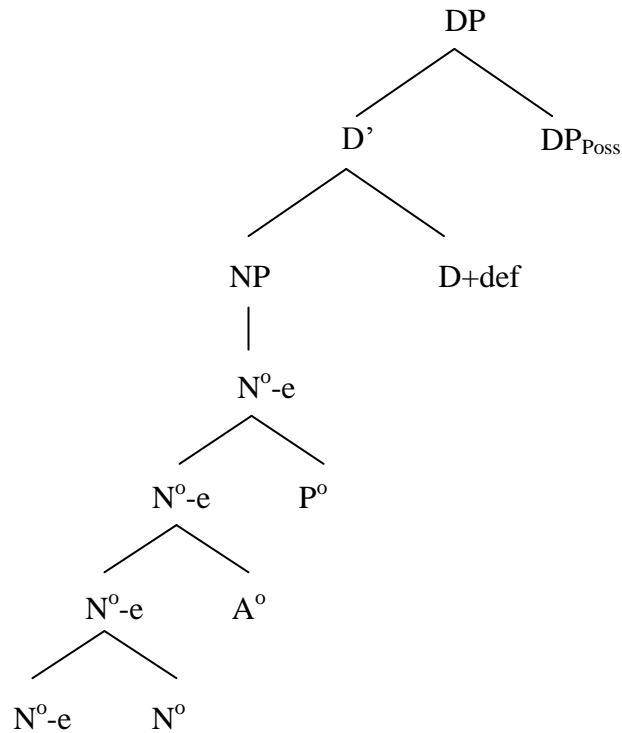

A crucial point in (163) is that the possessor DP is not dominated by the NP, but is instead base-generated as sister to D'. This follows from Ghomeshi's assumption that Persian nouns do not project. Since the latter cannot dominate phrasal material, the NP-internal position is excluded for the possessor, which can be fully phrasal. Thus, two options remain for its occurrence: a) either as a sister to NP, or b) as a sister to D'. The first option is abandoned by Ghomeshi, who advocates that the possessive DP be base-generated in [Spec,DP] position. Under this perspective, an empty D-head bearing the [+def] feature is required. The validity of the latter is further supported by the following facts: a) NPs including a possessor are obligatorily construed as definite or presupposed; b) possessors are in complementary distribution with the indefinite determiner *-i*.

The insertion of the Ezafe vowel is accounted for through a PF insertion rule.

(164) Ezafe Insertion Rule (Ghomeshi, 1997: 91)

Insert the vowel *-e* on a lexical X^0 that bears the feature [+N] when it is followed by phonetically realized, non-affixal material within the same extended projection.

The Ezafe insertion rule predicts that a noun within the modifying PP cannot appear with a possessor when the PP occurs within the Ezafe construction, as shown in (165b), whereas it can if the PP is appositive, as exemplified in (165c):

- (165) a. otâq-e kučik-e zir-e širvuni-e Ali
 room-EZ small-EZ under-EZ roof-EZ Ali
 “Ali’s small room under the roof” (*Samiiian, 1983:39*)
- b. * otâq-e kučik-e zir-e širvuni-e Jiân-e Ali
 room-EZ small-EZ under-EZ roof-EZ Jian-EZ Ali
 (putatively) “Ali’s small room, under Jian’s roof”
- c. otâq-e kučik-e Ali, zir-e širvuni-e Jiân
 room-EZ small-EZ Ali under-EZ under-EZ Jian
 “Ali’s small room, under Jian’s roof”

Adapted from Samvelian (2007: 614)

These examples show that class 2 and class 3 prepositions behave like adjectives, in that they cannot take a phrasal complement within the Ezafe domain. Concerning class 1 prepositions, which are real prepositions, Ghomeshi suggests that they exhibit a dual nature: they can either take phrasal complements in the syntactic domain, or form compounds in the lexicon.

The analysis put forward by Ghomeshi presents some drawbacks. Prepositional phrases seem to resist her account. These can occur within the Ezafe domain, so one would expect that they are bare heads. However, as noticed by Samvelian (2007), they seem to take complements, as shown by the following example:

- (166) bahs-e bâ ajale-ye hasan jâleb bud
discussion-EZ with haste-EZ Hasan interesting be.PST
 “Hasan’s hasty discussion was interesting”

Moreover, Samvelian (2007: 614) provides evidence that Persian NPs can contain phrasal modifiers. The same holds for prepositions, which can occur within the Ezafe domain even when they head phrasal projections. Interestingly, Samvelian shows that even Class 1 prepositions may appear within the Ezafe domain, contra Samiian.

- (167) čerâ xâne-ye [PP be ân qašangi] râ foruxte
why house-EZ to that beauty sell.PST.PL
 “Why has she sold such a beautiful house?”

Adapted from Samvelian (2007: 616)

Ghomeshi (1997), agreeing with Samiian (1983), states that elements linked by the Ezafe to the head noun occur in a fixed order:

- (168) Head N – Attibutive N – A – PP – DP_{Poss}

It should be noted that, according to Samvelian, the only absolute constraint concerns the placement of the possessor DP, which must be realized in the final

position within the Ezafe domain. Within this domain, other elements linked by the Ezafe are by preference ordered as in (168), but they may also be ordered differently.

Finally, it appears that the only modifiers that cannot be linked to the head noun are relative clauses. In general, it turns out that Samiiian and Ghomeshi's many restrictions regarding prepositions and the fixed order of elements within the Ezafe domain turned out to be ill-founded. Moreover, Ghomeshi's hypothesis that Persian nouns do not inherently project seems to face serious challenges, due to the fact that Persian NPs can dominate phrasal material. An important question that seems to remain unanswered by either of the aforementioned accounts is why we do not get Ezafe pre-nominally, an issue that is taken up by Larson and Yamakido (2008).

5.2.3 Larson & Yamakido (2008)

Larson & Yamakido in their 2008 paper confess that they find Samiiian's (1994) case-based analysis of Ezafe convincing. Thus, based on Samiiian, they further develop the hypothesis that Ezafe is a case-assigner for post-nominal [+N] elements.

Larson & Yamakido's proposal has its roots in the theory of DP structure developed in Larson (2000). In this work, Larson claims that the DP contains its own independent case system. It is proposed that Ezafe is a reflex of this system. Let me present the basics of this theory.

Larson adopts the relational view of D, introduced by Barwise & Cooper (1981) and Keenan & Stavi (1994), according to which determiners express relations between sets. For instance, the determiner *the* is analyzed as follows:

$$(169) \text{ THE}(X, Y) \text{ iff } Y \subseteq X \text{ and } |Y| = 1$$

In DP quantification, the internal argument of D normally gives the set Y; the nominal that D combines with, usually referred to as the restriction of quantification. Similarly, the set X, which is given by the external argument of D, constitutes the expression that DP is adjoined to. The latter is usually called the scope of quantification.

So, determiners, like verbs, are theta role assigners. According to Larson's (2000) proposal, there is a hierarchy of θ -roles for D, parallel to, but distinct from the hierarchy of θ -roles for V. Notice that the θ -roles are projected in the DP analogously to the projection of θ -roles in the VP.

- (170) a. D: θ SCOPE > θ RESTRICT > θ NOBLIQUE
 V: θ AGENT > θ THEME > θ GOAL > θ OBLIQUE

Larson (2000) suggests that notions like scope and restriction be understood as thematic roles assigned by the determiners to their set arguments, obeying the above hierarchy.

The parallel thematic analysis of D and V allows for a parallel account of structure, according to Larson (2000). Here is a schematic overview of his shell theory (1988).

- | | | |
|-------|---|--------------------------------|
| (171) | DP-shell structure | VP-shell structure |
| | • Simple quantificational D | Transitive Vs |
| | • "Ditransitive" ³¹ D | Ditransitive Vs |
| | • D/ δ assigns case | V/v assigns accusative |
| | • Little δ triggers raising of D | Little v triggers raising of V |

³¹ Larson uses this term for determiners like *every...except or more...than*.

Within this general framework verbal and nominal modifiers are not analyzed as adjuncts, but as oblique complements of V/D. Let us see what structure is assigned by Larson to a VP and a DP respectively:

(172)

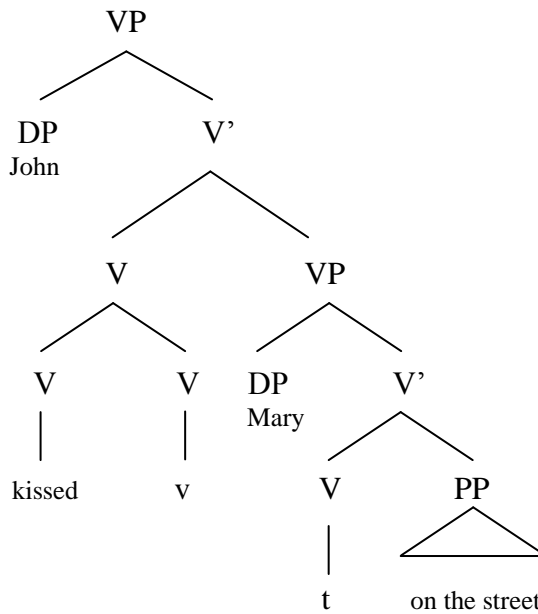

${}^{\theta}\text{AGENT} > {}^{\theta}\text{THEME} > {}^{\theta}\text{LOC}$

Larson & Yamakido (2008: 54)

Analogously:

(173)

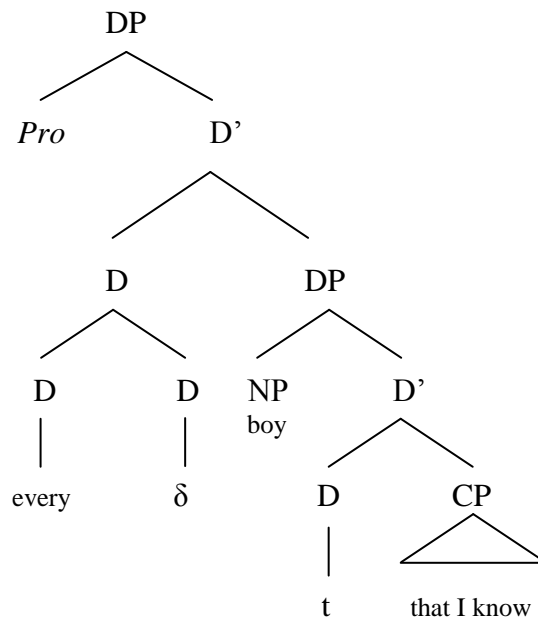

${}^{\theta}\text{SCOPE} > {}^{\theta}\text{RESTRICT} > {}^{\theta}\text{NOBLIQUE}$

Larson & Yamakido (2008: 54)

Let me now discuss how the Ezafe construction is captured by Larson & Yamakido (2008)³².

The authors suppose that DP is like VP as far as its system of Case-marking is concerned. [+N] complements of D need Case; they bear a Case feature that must be checked. D/ δ has only one Case to assign on its internal argument; this is reserved for its NP restriction. Since [-N] elements (like PPs and CPs) do not have a Case feature to be checked, they remain in situ. On the other hand, [+N] modifiers must somehow acquire case. If no case-marker is available in situ (as is the case in English), such modifiers “move to a site where Case is available” (and so end up to the left of N). By hypothesis, Persian has a case-marker that does license these modifiers in situ, namely Ezafe. Larson & Yamakido propose that Ezafe forms an XP phrase with its complement, but cliticizes onto the preceding nominal element for phonological reasons. Since Ezafe case-licenses the adnominal modifiers in situ, they stay in their base position. As in English, relative clauses and non-nominal PPs are automatically absolved from these requirements, as they do not need Case.

Under this proposal, the Ezafe languages present a special characteristic, in the sense that, due to their interesting case-marking device, they reveal the deep position of adnominal modifiers. The structure in (174) shows how Larson & Yamakido (2008: 61) analyze a phrase in which Ezafe is involved.

- (174) a. in ketâb-e sabz-e jâleb
 DEF book-EZ green-EZ interesting
 “The interesting green book”

³² I do not discuss possible advantages and drawbacks of Larson’s shell theory, since this is beyond the aims of the present chapter. For detailed discussion, see (Larson, 2000 and Larson & Yamakido, 2005/2008 among others).

b. $[_{DP} \text{Pro } [_{D'} \text{in } [_{DP} \text{ketâb } [_{D} t' [_{DP}[_{XP} \text{e sabz}] [_{D'} t' [_{XP} \text{e jaleb}]]]]]]]]]$



CASE



CASE



CASE

To sum up, Larson & Yamakido's proposal is closely related to Samiian's (1994) analysis. Both view the Ezafe particle as a case-marker, based on the same range of data. We have seen that Samiian (1994) argues that Ezafe should be considered as a dummy case-assigner occurring with non-case-assigning heads (nouns, adjectives and Class 2 prepositions) and enabling them to case-license [+N] categories. In the same vein, Larson & Yamakido (2008) suggest viewing the Ezafe as forming a constituent XP with the complements whose case it licenses. Then, D selects this XP.

However, a crucial question arises for both of these accounts. Since case-marking is typically (and according to the widely held view) associated with argument status, why should modifiers require Case? Larson & Yamakido's answer to this question is based on the theory of DP-structure they adopt (see above, and Larson, 2000): most adnominal modifiers are arguments after all, namely arguments of D.

A major drawback for these accounts, mentioned by Samvelian (2007), is that the data they rely on are not well-grounded. Indeed, both Samiian and Larson & Yamakido's analyses are mainly based on the claim that constituents such as PPs (see Class 1 prepositions) and relative clauses, which do not need to be case-marked, are excluded from the Ezafe domain. However, as was shown in (175), some class 1 prepositions *can* occur within the Ezafe domain. Moreover, although it is true that

relative clauses cannot be linked to the head noun by the Ezafe, reduced relatives *are* introduced by this particle. Samvelian (2007: 16) uses the following example, taken from a novel (F. Behnud, *In se zan*, p. 55):

- (175) nasm-e ostân tavassot-e in javân-e
order-EZ province by means-EZ this young-EZ
 [RRC az suis bar gašte] bištar hâsel xâhad âmad
from Switzerland back turn.PST.PL more gained AUX come.PST
 “Order in the province will be better established by this young
 man (who has) come back from Switzerland.”

Evidently, it remains completely unclear why class-1 PPs and reduced relatives in the Ezafe domain should require case-licensing.

There are further objections to the Larson & Yamakido’s proposals, but I postpone discussion of these to section 5.3.

5.2.4 A brief outline of Samvelian (2007)

Samvelian (2007), in her HPSG account, suggests a rather different analysis of Ezafe in comparison with the previous ones. According to her account, Ezafe is better viewed as a suffix attaching to the head and to some intermediate projections, and marking them as awaiting a modifier or complement. Under this perspective, the Ezafe construction is an illustration of the head-marked pattern of morphological marking of grammatical relations (Nichols, 1986).

As already mentioned, Samvelian observes that in fact prepositions and reduced relatives can partake in the Ezafe construction. Another observation made

by Samvelian is that not only words, but also phrasal constituents can be linked to the head noun by the Ezafe. This is illustrated in the following example:

- (176) mard-e negarân-e bačče-hâ-yaš vâred šod
man-EZ worried-EZ children-PL.PAF.3SG entered become-PST
 “The man worried about his children entered.”

Samvelian (2007), working on the basis of distributional, prosodic and morphological criteria, establishes two main sets of inflectional affixes within the Persian NP: a) the word-level inflectional affixes *-(h)e* (definite suffix) and *hâ* (plural suffix), and b) the phrasal affixes, i.e. the Ezafe, the determiner *-i* and personal enclitics. The comparison between the members of these two sets shows that they present a number of different properties, as listed below:

- (177) 1st Set: *-(h)e* and *hâ*
- a. They are in complementary distribution.
 - b. They occur on the head noun within the NP.
 - c. They cannot be separated from their host by another inflectional affix.
 - d. They bear lexical stress.
 - e. They cannot have wide scope over coordination.

Adapted from Samvelian (2007: 618)

Crucially, according to Samvelian (2007), the definite suffix *-(h)e* may combine with the Ezafe, as illustrated by the author in the following example:

- (178) in bâr âhang hamân-i bud ke pesar-e-ye
this time melody same- be.PST that boy-DEF-ez
RESTR.
 film-e hendi barâ-ye doxtar-e mi-zad
film-EZ Indian for-EZ girl-DEF MA-beat.PST
 “This time the melody was the same as the one the boy in the
 Indian film was playing for the girl.”

In (178), the co-existence of the definite suffix and the Ezafe is expected, because they belong to different sets, and thus they occupy different morphological slots³³.

(179) shows the properties that Samvelian attributes to the second set of elements, namely the phrasal affixes.

- (179) 2nd set: *Ezafe, indefinite -i, forms of personal enclitics*
- a. They are in complementary distribution.
 - b. They do not necessarily occur on the head noun within the NP and can attach to the right edge of some intermediate projections.
 - c. They are compatible with set 1 affixes and are placed after them.
 - d. They do not bear lexical stress.
 - e. They can have wide scope over coordination.

Adapted from Samvelian (2007: 621)

The above properties explain why examples in which the Ezafe co-occurs with the indefinite suffix are ungrammatical. Both morphemes compete to occupy the same morphological slot. In other words, they belong to the same set and, as a

³³ See Stump (2001), who develops a morphological theory in terms of position class morphology, where groups of affixes (among other elements) compete for realization in a specific slot.

consequence, they are rival possibilities for the same slot³⁴. Consider the relevant example below:

- (180) *ketâb-i-e Mina
 book-INDEF-EZ Mina
 *‘‘a book of Mina’’

Samvelian’s analysis suggests that a typical Persian phrase involving Ezafe would have a structure like the one depicted in (182):

- (181) moġgân-e az rimel sangin-e maryam
 eyelid.PL-EZ of mascara heavy-EZ Maryam
 ‘‘Maryam’s mascara-laden eyelids’’

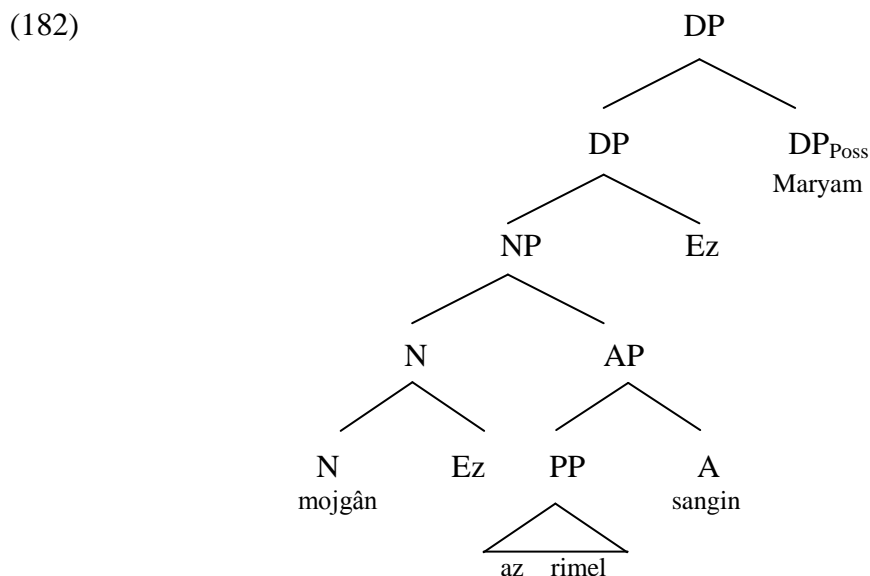

³⁴ This is true only for Persian Ezafe. In languages like Sorani, Kurmanji and Hawramami the Ezafe suffix can combine with the indefinite suffix. Samvelian (2007) underlines that this contrast in the behaviour of the indefinite suffixes between these languages can be accounted in terms of position class morphology: while in Persian the Ezafe and the indefinite determiner occupy the same slot, in the other languages, these two elements occupy different slots, thereby allowing their co-existence.

In Samvelian’s account, which is developed in the HPSG framework, the Ezafe suffix is introduced through application of a lexical rule (see Samvelian 2007: 635 for the corresponding diagram in terms of HPSG).

5.2.5 Ezafe as a linker (Ruff, 2008)

Although much work has been devoted to the analysis of Ezafe, little attention has been given to arguments from constituency tests for its structural realization. Ruff (2008) is concerned with the syntax of so-called linkers: syntactically independent, semantically empty particles, whose sole function is to indicate the existence of a relationship between two items (their usage being most prevalent within the complex noun phrase; see Den Dikken & Singhapreecha, 2004, Samvelian, 2006: 26). Ruff presents convincing evidence that Ezafe is a linker that forms a constituent with the dependent in a head-dependent relation.

Fronting cannot be used as a diagnostic, since movement out of the Ezafe domain is impossible (Samvelian, 2006: 4). Ruff supposes that this probably happens because the enclitic Ezafe would have to move with its syntactic dependent, but then it would not have any phonological support. However, relevant coordination data can be used as a constituency test. Consider the following examples:

- (183) [kif (*-e) va ketâb][-e maryam]
 bag-EZ and book-EZ Maryam
 “Maryam’s bag and book.”

- (184) ketâb[-e [maryam va(*-ye) mina]]
book-EZ Maryam and-EZ Mina
“the book of Maryam and Mina.”

In (183), two coordinated NPs are related to a single dependent, the possessor *Maryam*. It is not possible for the Ezafe to be realized on each conjunct. Rather, the linker may appear only once, adjacent to the dependent. Under Ruff’s hypothesis that the Ezafe forms a constituent with this dependent, this can be reasonably explained. However, somewhat unexpectedly, the Ezafe cannot be repeated in (184), which contains a coordination of two dependents. Ruff argues that the obligatory omission of the second Ezafe can be attributed to a phonological restriction: it is conceivable that it cannot be cliticized onto a coordinating conjunction.

The above coordination data, where the Ezafe must have scope over both conjuncts constitutes strong evidence that the Ezafe is in fact an independent syntactic word. This means that it is a clitic, as opposed to an affix, and thus, a linker. It should be noted that this view of Ezafe as an independent syntactic word is also maintained by Bögel et al. (2008).

Coordination data, such as (183), remain mysterious under a phrasal-affix analysis, like the one suggested by Samvelian (2007). Samvelian (2007: 631) herself recognizes this drawback: “It is not clear to me what the interpretation of this fact [that the Ezafe particle cannot cliticize to each conjunct] may be”. But, as Ruff notes, if *-e* is understood as a clitic (linker) forming a constituent with its dependent, such data fall out in a natural way.

5.3 Persian Ezafe and Greek polydefinites

As already discussed in §5.2.3, Larson & Yamakido (2008) propose an analysis according to which the Ezafe particle is a case-marker that case-licenses post-nominal [+N] elements. However, these authors try to extend their analysis to other constructions of post-nominal modification, in particular also the Greek polydefinite construction. I will first outline how these authors try to correlate Ezafe with polydefiniteness. Subsequently, I will argue that this correlation is poorly motivated on both empirical and theoretical grounds.

5.3.1 Greek polydefinites in a DP-shell analysis

It is well known (see chapters 2 and 3) that Greek, like English, displays pre-nominal restrictive adjectives in definite DPs that typically cannot appear post-nominally:

- (185) a. to mikro vivlio
the small book
- b. *to vivlio mikro
the book small

Larson & Yamakido (2008) mainly follow Alexiadou & Wilder's (1998) analysis of polydefinites and adopt the latter's view that determiner spreading is only possible if two constraints are met. First, the adjectives undergoing determiner spreading must be interpreted restrictively; second, only intersective/predicative adjectives are allowed in the construction. Larson & Yamakido use the two examples in (186) and

(187), from Marinis & Panagiotidis (2004) and Alexiadou & Wilder (1998), respectively, to illustrate each of the aforementioned constraints.

- (186) a. O diefthindis dilose oti i ikani erevnites
the manager declared that the competent researchers
 tha eprepe na apolithun.
 FUT. had to be fired
 “The manager declared that the competent researchers should be fired.”
 (either restrictive or non-restrictive interpretation).
- b. O diefthindis dilose oti i erevnites i ikani
the manager declared that the researchers the competent
 tha eprepe na apolithun.
 FUT. had to be fired
 “The manager declared that just the competent researchers should be
 fired.” (only restrictive interpretation)

In (186a), the pre-nominal adjective *ikani* can be interpreted either restrictively or non-restrictively. On the other hand, in (186b) the same adjective, which is post-nominal and partakes in a polydefinite construction, can receive only a restrictive interpretation.

- (187) a. o ipotithemenos dolophonos
the alleged murderer
- b. *o dolophonos o ipotithemenos
 (cf. *o dolophonos itan ipothimenos. ‘The murderer was alleged.’)
- c. i italiki isvoli
the Italian Invasion

- d. * i isvoli i italiki
(cf. *I isvoli stin Alvania itan italiki. ‘The invasion of Albania was Italian.’)

In (187), it is shown by Larson & Yamakido, in agreement with Alexiadou & Wilder, that non-intersective/non-predicative adjectives are excluded from the polydefinite construction.

Larson & Yamakido (2008) argue that these properties of polydefinites fall out naturally if they are analyzed as involving a D-shell, with head-to-head raising of the determiner, as outlined earlier for the Ezafe construction. But if their analysis makes certain predictions on the kind of adjectives (e.g. non-intersective) that should resist determiner spreading, the same predictions should logically hold for the Ezafe construction. In other words, they should predict that non-intersective or non-predicative modifiers should remain outside the Ezafe domain. The authors do not discuss this issue at all, but it seems that such constraints do not apply in the Ezafe construction. Nowhere in literature, has it been mentioned that, for instance, non-intersective adjectives cannot partake in an Ezafe sequence.

On Larson & Yamakido’s analysis, multiple modifiers require the base-generation of multiple DP-shells through which D raises recursively. They furthermore hypothesize that, as D raises through the DP-shells, it has the possibility to leave behind a copy whose formal (but not semantic) features are active. Thus, assuming that each copy of D checks the Case features on its complement, it is expected that an additional D Case becomes available for each copy of D, thereby allowing an AP to remain in situ for each copy:

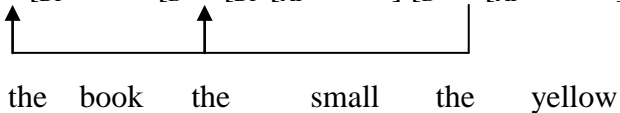
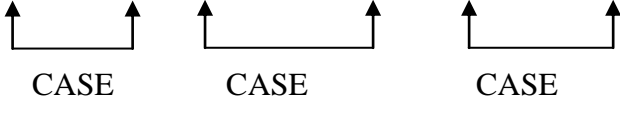
- (188) a. $[_{DP} \text{Pro}[_{D'} \text{to}[_{DP} \text{vivlio} [_{D'} \text{to}[_{DP} [_{AP} \text{mikro}] [_{D'} \text{to} [_{AP} \text{kitrino}]]]]]]]$

the book the small the yellow
- b. $[_{DP} \text{Pro}[_{D'} \text{to}[_{DP} \text{vivlio} [_{D'} \text{to}[_{DP} [_{AP} \text{mikro}] [_{D'} \text{to} [_{AP} \text{kitrino}]]]]]]]$

CASE CASE CASE

If D does not leave any copies behind, no Case is assigned to the corresponding APs/NPs, causing ungrammaticality unless the caseless modifier undergoes raising to a position left of N.

- (189) a. to mikro kitrino vivlio
the small yellow book
- b. *to vivlio mikro kitrino
the book small yellow

In this way, Larson & Yamakido (2008) explain why determiner spreading allows the post-nominal position of adjectives in Greek. In parallel, they unify the Ezafe and the Greek polydefinite construction in terms of their D-shell account, suggesting that in Greek copies of D assign Case to the APs/NPs, while this function is fulfilled by the Ezafe morphemes in Persian.

5.3.2 Can Persian Ezafe and Greek polydefinites be unified? Empirical issues

In order to answer the question in the title, it is necessary to explore the two components which it consists of. First, are there any proposed accounts that could allow or imply any correlation for these phenomena, apart from Larson & Yamakido

who immediately corralate them? Second and more crucial, do the constructions have properties in common that would justify an analysis of them being two sides of the same coin?

As far as I am aware, one account of Greek polydefinites that could potentially and partly be analogous to one of Ezafe is that of Kolliakou (2004). Kolliakou argues for the affixal status of the definite determiner in an approach implemented in HPSG. Recall that Samvelian (2007) suggests that Ezafe be a phrasal affix, interestingly in an HPSG account again (see §5.2.4). Let me briefly give an outline of Kolliakou’s proposal. Then I will discuss why a unified account (like Larson & Yamakido’s or a possible extension of Kolliakou (2004) to Ezafe) of these phenomena should be rejected.

Kolliakou uses six pieces of evidence in favour of viewing the definite determiner in Greek as a (phrasal) affix. First, the definite determiner cannot occur on its own (190a), nor can it host a possessive suffix (190b):

- (190) a. Prosferan glika. Pira merika.
offer.3PL.PST sweets take.1SG.PST some
 They were offering sweets. I took some.
 *... pira ta
 ... took the
- b. Orismena tu vivlia
certain of his books
 “some of his books”
 * ta tu vivlia
the of his books
 Putatively: “his books”

According to Kolliakou (2004) both the above facts are compatible with an affixal approach.

Second, the distribution of the definite determiner in polydefinites is reminiscent of the ‘floating’ distribution of the ‘weak form’ possessive. Both can be attached to the same range of hosts (nouns, adjectives and numerals), despite the fact that the former is a prefix (proclitic) and the latter a suffix (enclitic).

- (191) a. ta vivlia tus
 the *books* *of theirs*
 “their books”
- b. ta mikra tus (ta) vivlia
 the *small* *of theirs* *(the)books*
 “Their small books”
- c. ta dio tus (ta) vivlia
 the *two* *of theirs* *(the) books*
 “Their two books”

The third piece of evidence comes from the phonological phenomenon of Stop Voicing. As Kolliakou (1999) shows, the voicing of a stop preceding a nasal occurs either inside plain morphology words (antidra^si “reaction” → [and^didra^si]), or inside clitic morphology words (yiatron tu “of his doctors” → [yiatron **du**]), but not across words (kathigiton taktikon “of tenured professors” → *[kathigiton **d**aktikon]). The definite determiner followed by a nominal pattern with plain and clitic morphology words as in the example: tin kardia “the.ACC heart” → [ti **g**ardia].

The fourth test relies on data from coordination. The Greek definite determiner appears to take wide scope over coordinated nominals that are co-referential (192). On the other hand, when the two conjuncts have distinct reference,

the definite determiner cannot be construed as having wide scope over the coordinate structure (192). Consider the following example:

- (192) a. O [filos ke sinadelfos] tu patera mu
the friend and colleague of father my
 “The friend and colleague of my father’s”
- b. * Ta [vivlia tu Yani] ke [molivia tis Marias]
the books of Yannis and pencils of Maria
 Putatively: “The books of Yannis’s and the pencils of
 Maria’s”

In (192a), the phrase contains a single definite determiner and it is grammatical, because *filos* ‘friend’ and *sinadelfos* ‘colleague’ pick out the same individual. On the other hand (192b), in spite of the fact that it contains a single definite determiner as well, cannot be construed as having wide scope over a coordinate structure consisting of nominals with distinct reference.

The fifth diagnostic is based on demonstratives. Greek demonstratives are required to occur in definite NPs (see (193)) and they cannot act as definite article hosts (193c). NP-internal demonstratives resist possessive affixes (193e). Kolliakou (2004) remarks that such facts can be straightforwardly accounted for under the affix treatment, since such arbitrary gaps are common in the morphological paradigm of genuine inflectional affixes, but less consistent with a postlexical clitic approach.

- (193) a. to-mikro afto vivlio /afto to-mikro vivlio
 the small this book /this the small book
 “this small book”
- b. *mikro afto vivlio /*afto mikro vivlio
- c. *to-mikro to-afto vivlio /*to-afto to-mikro vivlio
- d. to-mikro **tu** afto vivlio
 the small of his this book
 “*This small book of his*”
- e. *to-mikro afto **tu** vivlio

Finally, always according to Kolliakou (2004), it seems intuitively correct that for both monadics and polydefinites there is a syntactic requirement for just one definite determiner. This determiner is arguably associated with the head noun. Also, it is widely accepted that, from a semantic point of view, the contribution of the definite determiner in both monadics and polydefinites is integrated into the meaning of the phrase just once. For example, the phrases *to mikro vivlio* and *to mikro to vivlio* have the same meaning, namely ‘the small book’. As Kolliakou says, the requirement that in the latter case the index should be anchored to an entity that is a proper subset of a salient set cannot be pinned onto the extra definite article. Furthermore, a postlexical clitic approach of the definite determiner would mean that the article would a priori be expected to be syntactically licensed more than once, namely as many times as it occurs in any given polydefinite. On the other hand, within an affixal approach the multiple realization of the definite determiner can be treated as a mere option giving rise to monadics, polydefinites and DPs in partial DS.

The analysis of the definite determiner as a (phrasal) affix may create second thoughts that the phenomenon of polydefinites is quite similar to the Ezafe

construction. For instance, it is indeed true that both the definite determiner in Greek and the Ezafe particle in Persian cannot occur on their own. Also, both seem to be parts of larger constituents and favour the appearance of post-nominal elements. But are these reasons enough to support a fundamental unification of the two constructions?

I think that there is no real basis for a correlation of Ezafe with polydefinites. Even if Kolliakou (2004) is on the right track, viewing the definite article as an affix, it has been discussed in §5.2.5, in line with Ruff (2008), that the Ezafe particle is a linker. This means that, contra an affixal analysis, the Ezafe morpheme is an independent syntactic word forming a constituent with its dependents. As shown in (183) and (184), the fact that the Ezafe must have scope over both conjuncts in coordination provides strong evidence that it is an independent syntactic word. By contrast, as demonstrated in (192b), the definite determiner in Greek cannot have scope over both conjuncts or the phrase becomes ill-formed. This obviously does not favour an analysis of the Greek definite determiner as a clitic. This is an important empirical piece of evidence, which suggests that the Persian Ezafe and the Greek polydefinite construction are different.

However, the main reason why Persian Ezafe and Greek polydefinite constructions should be considered different phenomena is their syntactic configuration. There are major differences between them that manifest the different nature of these phenomena.

First, Ezafe is present in a broader range of syntactic structures than determiner spreading. Recall that Ezafe can appear in strings with attributive adjectives (and with complements of them), attributive nouns (and with

complements of them), possessor NPs, some prepositions (Class 2), complements of long infinitives, partitives, even with instances of reduced relatives (see section 5.2). On the other hand, determiner spreading mainly refers to instances of adjectival modification (including numerals). DS is incompatible with complements of adjectives (see (194a)), prepositions (see (194b)) and reduced relatives. It is though compatible with some adverbials that syntactically function as adjectives (see (194c)).

- (194) a. * O periphanos gia tin kori tu o pateras
the proud for the daughter of his the father
 Putatively: “The proud father for his daughter”
- b. * O ilios o meta ti vrohi ine oreos
the sun the after the rain is beautiful
 Putatively: “The sun after the rain is beautiful”
- c. I kato i kerassia ine marameni
the down the cherry-tree is withered

The context of (194c) is that there are two cherry-trees in the garden. The first is in the upper side of the garden, while the second is in the opposite side. In this case, a phrase like the one in (194c) is felicitous.

Second, Ezafe appears only with post-nominal modifiers; never pre-nominally. The word order variation is not so strict within the Ezafe domain (see section 5.2), but all the relevant permutations are allowed only post-nominally (head initial word order). By contrast, determiner spreading gives rise to freer word order, allowing both pre-nominal and post-nominal modification. There is also a possibility of having partial DS, where some but not all the definite determiners are present.

Third, Ezafe is recursive, as illustrated in the following example (adapted from Pancheva, 2007):

- (195) ængushtær-e firuze-ye bozorg
ring-EZ turquoise-EZ big
 “big turquoise ring”

Notice that everything that follows the noun has an Ezafe, but not the noun itself. DS though has to appear even before the rightmost adjective, and crucially a bare adjective is not permitted in a polydefinite construction. To make it clearer, compare (195) with the following example:

- (196) a. to mikro to vivlio to kokino to akrivo
 the small the book the red the expensive
 b. * to mikro to vivlio to kokino akrivo
 the small the book the red expensive

Moreover, it has been shown in chapters 2 and 3 that a DP in DS always has a restrictive interpretation independently of the pre- and post-nominal position of the modifiers. As far as I am aware, the Ezafe construction has not been associated with any special interpretive effects. In the same vein, as mentioned earlier, the definite determiner has a semantic contribution in any given phrase; thus, in polydefinites, as well. On the other hand, Ezafe does not contribute semantically in a phrase, which is also apparent from the fact that it occurs in both definite and indefinite DPs. By contrast, a Greek polydefinite contains only definite determiners and cannot contain

a mixture of definite and indefinite determiners, since these are semantically incompatible³⁵.

That the Ezafe particle is compatible with both definite and indefinites is demonstrated by (150) and (197) respectively, with an exception though.

- (197) a. ketâb-e xub-e jaleb-i
book-EZ good-EZ interesting-INDEF
 “an interesting good book”
- b. ketâb-i xub
book- INDEF good
 “a good book”
- c. kelid-e dær-i
key-EZ door-INDEF
 “a/the key of some door”
- d. *kelid-i dær
key-INDEF door

From the examples in (197), it becomes clear that in Noun + Adjective structures the indefinite suffix *-i* can be added to the (last) adjective (197a). Moreover, if the indefinite suffix is added to the noun (there is such possibility in Persian), Ezafe is not allowed (197). In Noun + Noun sequences, the indefinite suffix has to be attached to the attributive noun, which is linked to the head noun by Ezafe (see (197c)). The other way around, attachment of the suffix *-i* leads to ungrammaticality (see (197d)).

³⁵ Of course, in chapter 4, I maintained that there are *polyindefinites*. But, similarly a *polyindefinite* cannot contain a definite determiner, thus the existence of *polyindefinites* is irrelevant to the present discussion. The point I am making here is that the Ezafe particle can appear both in definite and indefinite linguistic contexts.

As we have seen, Larson & Yamakido offer an explanation for the post-nominal position of adjectives via determiner spreading, but they do not mention at all that DS is also possible pre-nominally (*to mikro to kitrino to vivlio* “the small the yellow the book”). Of course, this is an empirical difference that all unified approaches would be struggling with. It seems rather unexpected to have pre-nominal determiner spreading in their account, as it stands. The consequent word order variation remains unexplained.

Samvelian (2007) has shown that the Persian data on which Larson & Yamakido’s account is based are not well-grounded. The Greek data are problematic as well, and this affects their argumentation for the polydefinite construction. More specifically, they rely on Alexiadou & Wilder’s (1998) major generalization that only predicative/intersective adjectives permit determiner spreading. As has been argued in chapters 2 and 3 this generalization is on the right track. Nevertheless, the examples Larson & Yamakido take from Alexiadou & Wilder and Panagiotidis & Marinis (see (189)) are not properly selected, because they are not indicative of the ‘scope’ relations that exist among the various elements. Also, as argued in chapter 3, some standardly treated as non-intersective adjectives, like *fake*, can partake in the polydefinites construction, since they are compatible with intersection.

Moreover, as shown in chapter 3, ‘true’ Ethnic adjectives, like Italian ‘italikos’, Greek ‘elinikos’ etc., are not allowed in polydefinites. But, Ethnic adjectives have a homophonous relational counterpart that can be used predicatively (198b) and permit DS (198a)³⁶. Consider the following example:

³⁶ Alexiadou & Wilder (1998) seem to imply that only the ‘true’ Ethnic adjectives (with a by-interpretation) resist DS and not their relational homophonous counterparts. Larson & Yamakido though, do not appear to acknowledge this distinction. They generally talk about adjectives of nationality.

- (198) a. Ta proionda ta elinika ine kalitera apo ta italika
the products the Greek are better than the Italian
“The Greek products are better than the Italian ones.”
- b. To proion ine eliniko. Embistefsou to.
the product is Greek. Trust it.
“The product is Greek. Trust it.”

To sum up, the above facts constitute strong evidence, I think, against a unified account of Persian Ezafe and Greek polydefinite constructions.

5.3.3 Theoretical issues in Larson & Yamakido’s (2008) account

Larson & Yamakido argue that the determiner in the Greek polydefinite construction checks the Case features in its complements; hence, Case is assigned to the APs/NPs. This is the same proposal as in the Ezafe construction, where the Ezafe particle is considered a case-marker and functions so as to case-license [+N] elements. The question concerning this approach remains the same for both these phenomena: Why would modifiers need case in, say, Persian and Greek, since case-marking is typically associated with argument status and not modifiers? Clearly the consequences of their proposal extend beyond Persian or Greek. If a language lacks the case-marking tricks of say Greek, then post-nominal modifiers that need case must raise to a pre-nominal position. So the question to be asked is really: what is the empirical evidence that modifiers are case-marked by D? Of course there is evidence for case-endings on adjectives in Greek. But this is usually treated as an agreement phenomenon. The DP receives case from a DP-external case-assigner, and thereby the head of the projection. Adjectives show case concord. But if D assigned case,

would we then not expect that adjectives might have a case-ending that is different from that of the DP (since the case-markers are different)? This seriously challenges Larson & Yamakido's analysis, which appears to have no real answer to the above queries.

Of course, Larson & Yamakido (2005, 2008) adopt a theory of DP structure, according to which DP is projected from the thematic structure of determiners, just like VP is projected from the thematic structure of verbs. In this way, they try to overcome the crucial question posed above.

Moreover, Larson & Yamakido assume that D raises through the various DP-shells leaving copies behind. But, are there heads that move and leave copies? In addition, are there heads that move and that enter in a relation with a constituent both before and after the movement operation? This is a crucial question since recursive D-raising leaves behind a copy that checks the Case features on its complements. Thus, an additional D Case is available for each copy of D. This licenses an AP to remain in situ for each copy.

Brody (1994) introduces a fundamental principle of syntax, the so-called Generalized Projection Principle (GPP), which takes the following form:

(199) Generalized Projection Principle

Projectional requirements can involve only the root positions of chains
(i.e. they can hold in, and be satisfied by root positions only).

The GPP seems very well motivated empirically.

A first immediate consequence of the GPP is what Brody calls the Main Thematic Condition (MTC), according to which movement cannot land in a θ -position. The GPP thus accounts for a fundamental property of argument structure.

Furthermore, as far as I am aware a head can only enter case-marking and agreement relations in the foot of its chain. For example, in the case of verb movement in the Germanic languages, all the verbs end up in a cluster on the right (as in German or Dutch). If such verbs are associated with an object, then case-marking will have to precede movement. Or in V-to-C movement in Dutch (verb second), the verb assigns case to its object(s) from the root of the chain, but does not assign case to the argument in [spec,CP].

The GPP restricts the projection of a head to take place in the root of its chain only. For example, a chain [V,t] projects a VP in the position of t only. Since the GPP also entails the MTC, an XP must satisfy its thematic and other selectional requirements in the root of its chain only.

Brody argues that the GPP consists of two components, as Van de Koot (1994:3) mentions. First, the GPP states that projection involves a unique position in chain. This is associated with feature-checking: once a feature has been checked it becomes inoperative (or deletes). Second, the GPP says that the checking position for projectional features is the most deeply embedded position in the chain³⁷. Brody assumes that all positions in a chain must be projectionally identified. Let's suppose that projectional identification is associated with a projectional feature and projectional features are restricted to spread through a chain in upward direction only; in addition, that the unique checking position for projectional features in a

³⁷ For further discussion on this issue see Brody (1993, 1994, 1995, 1997) and Van de Koot (1994) among others.

chain was not the most deeply embedded position. This would mean that the position below the checking position would not be projectionally identified. Given the requirement that feature percolation in chains is strictly upwards, the GPP follows naturally.

It is clear, I think, that Larson & Yamakido's proposal violates the GPP. The assumption that the D raises successively through shells leaving copies behind and that this licenses one AP/NP in each shell is incompatible with the GPP. Feature-checking, once completed, becomes inoperative, as already said, so once D checks its Case features on its complements, the GPP would not allow D to enter into a new checking relation after head-movement. But, of course, this is exactly what Larson & Yamakido's account stipulates. Furthermore, in their analysis feature-checking does not take place in the most deeply embedded position, as required by the GPP, but in the positions where multiple copies of the head D are left. Crucially, the fact that the moved D head keeps a relation with a constituent (its complements) both before and after movement does not conform to the GPP. The GPP demands that an XP satisfy its requirements only in the root position of its chain. We may conclude that Larson & Yamakido's proposal faces a combination of empirical and conceptual problems that seem hard to overcome.

5.4 Concluding remarks

In this chapter, I have argued against an analysis of the Greek polydefinite construction on a par with the Persian Ezafe construction. I first looked in detail the use of the Ezafe particle, the basic facts, the constructions in which it can partake

and its peculiarities. Following that, I was concerned with several major accounts that have been proposed to capture the relevant facts, in a critical overview. This led me to adopt Ruff's proposal, according to which Ezafe is best regarded as a linker, being part of a dependent-marking structure.

After having considered the basic facts and accounts on Ezafe, I was especially occupied with Larson's & Yamakido analysis. These authors suggest that Ezafe and polydefiniteness are phenomena that can be unified. They take as a point of departure that Ezafe and polydefinites are constructions that "unexpectedly" permit the existence of post-nominal modifiers. Their theory of DP structure suggests that all DP modifiers begin post-nominally as complements of D and that Case is 'responsible' for their distribution. Under this perspective, they propose that the existence of post-nominal adjectives in DS in Greek is a case of copy raising. I explored this account for both the aforementioned phenomena and argued against it, most emphatically regarding Greek polydefinites, pointing out a number of empirical and conceptual shortcomings.

I also tried to investigate whether the Greek polydefinites and Persian Ezafe can indeed be analyzed similarly to each other, independently of Larson & Yamakido's proposal and its consequences. I outlined Kolliakou's point of view of the Greek definite determiner as an affix, in a way quite similar to that of Samvelian (2007), who considers Ezafe as a phrasal affix. I argued that this is not enough to allow a single account for both phenomena, which exhibit major syntactic, semantic and configurational differences.

CHAPTER 6

Conclusion

The main aim of this dissertation has been to propose an adequate account of the syntactic and interpretive properties of the Greek polydefinite construction. I have argued that Greek polydefinites are optimally analyzed on a par with close appositives, in view of core properties that these two constructions share. Following Lekakou & Szendrői (2007), I adopted a multi-headed structure of mutual adjunction for both polydefinites and close appositives.

I argued for a base-generation analysis of the various re-ordering possibilities of Greek polydefinites. I also introduced a new interpretive mechanism, arguing that the R-role identification proposal of Lekakou & Szendrői (2007) requires modification. The new mechanism successfully rules out ungrammatical strings that were allowable in the former. It also captures the peculiar property of the polydefinite construction, that each of its DP-parts is independently referential. Moreover, it predicts the fact that polydefinites are compatible only with restrictive readings. The status of R-index mechanism could possibly be valid in other languages, but this issue is not addressed in the thesis.

I also compared my account to an LCA-based proposal, that of Alexiadou & Wilder (1998). My conclusion, after detailed criticism, is that an analysis along these lines should be abandoned, due to a number of serious drawbacks, including overgeneration. This discussion was followed by a broader one, considering the drawbacks of allowing DP-internal movement as a free option in my own analysis of polydefinites structures. The availability of such movement has unwanted consequences, including redundancy and overgeneration problems. I then discuss in

some detail a solution to this quandary suggested in work by Szendrői (2010), who argues extensively that discourse-related DP-internal movement does not exist, because there is no trigger for such movement.

Based on native speakers' intuitions that polydefinites present weaker markedness effects than monadics, I discussed the correlation among (i) the sorting order (a primitive notion), which is a language-external concept; (ii) the semantic hierarchy (the grammaticalization of this language-external concept); (iii) the markedness effects associated with non-default sorting orders and (iv) the scope interactions in monadics and polydefinites. I concluded that, in monadics, markedness effects associated with non-default search orders are strong because they give rise to a violation of the semantic hierarchy. This account presupposes that marked orders are not generated through focus movement and I showed that an analysis in terms of movement is indeed not motivated. In polydefinites, the semantic hierarchy cannot be enforced because it can only be enforced in a single nominal extended projection. Thus, deviation from the default sorting order in polydefinites does not violate any grammar-internal constraints, with the result that markedness effects are much weaker. That scope effects nevertheless remain detectable in polydefinites strongly supports the view that search order is mapped onto hierarchical relations.

I furthermore argued that the restrictions on the kind of adjectives that can partake in the polydefinites construction can be derived from the underspecified properties of the null noun with which the adjectives combine and from the interpretive properties of the R-index mechanism. Essentially the construction is

restricted to adjectives that can be treated as intersective, assuming some form of ad hoc concept formation that extends the scope of the intersective analysis.

Another conclusion of this thesis is that the indefinite determiner in Greek is in fact null and that *ena* ‘a(n)’ is quantifier. In addition, the differences on the ordering of the adjectives and their restrictiveness between Romance and Greek suggest an analysis of Greek indefinite DPs along the lines of polydefinites, exhibiting hidden determiner spreading.

Finally, I argued against a unified account of the Greek polydefinite and Persian Ezafe constructions, after an extensive discussion of the properties of the latter and any possible correlation with the properties of the former. I also suggested that an analysis of these phenomena along the lines of Larson & Yamakido (2008), as involving case-marking should be abandoned.

REFERENCES

- Abels, Klaus and Ad Neeleman (2006). "Universal 20 without the LCA". *Ms. UCL*.
- Abney, Steven P. (1987). *The English noun phrase in its sentential aspect*. Ph.D. Dissertation, MIT, Cambridge, MA.
- Ackema, Peter and Ad Neeleman (2004). *Beyond Morphology*. Oxford: OUP.
- Acuña Fariña, Juan Carlos (1999). "On apposition". *English Language and Linguistics* 3: 59-81.
- Alexiadou, Artemis (2001). "Adjective Syntax and Noun Raising: Word order asymmetries in the DP as the result of adjective distribution". *Studia Linguistica* 55.3: 217-248.
- Alexiadou, Artemis (2003). "Adjective Syntax and (the absence of) noun raising in the DP". *Proceedings of the Workshop on Head-movement*. UCLA, 1-39.
- Alexiadou, Artemis (2006). "On the cross-linguistic distribution of (in)definiteness spreading". Handout of the talk given at OLT Syntax Workshop, Klagenfurt
- Alexiadou, Artemis and Chris Wilder (1998). "Adjectival modification and multiple determiners". In Alexiadou, A. and Wilder C. (eds.), *Possessors, predicates and movement in the DP*. Amsterdam: John Benjamins, 303-332.
- Alexiadou, Artemis, Liliane Haegeman and Melita Stavrou (2007). *Noun Phrase in the Generative Perspective* (Studies in Generative Grammar 71). Mouton de Gruyter.
- Alexiadou, Artemis and Melita Stavrou (to appear). "Ethnic Adjectives as pseudo-adjectives: a case study in syntax-morphology interaction and the structure of DP". *Studia Linguistica*.

REFERENCES

- Androutsopoulou, Antonia (1994). "The distribution of the definite determiner and the syntax of Greek DPs". In Beals, K. et al. (eds.), *Papers from the 30th Regional Meeting of the Chicago Linguistic Society*. University of Chicago, 16-29.
- Androutsopoulou, Antonia (1995). "The licensing of adjectival modification". *Proceedings of WCCFL 13*. Stanford: CSLI Publications.
- Barwise, J., and R. Cooper (1981). "Generalized Quantifiers and Natural Language". *Linguistics and Philosophy* 4: 159-219.
- Blakemore, Diane (2006). "Divisions of labour: The analysis of parentheticals". *Lingua*, 116: 1670-1687.
- Bloomfield, Leonard (1933). *Language*. London: G. Allen and Unwin.
- Bögel, Tina and Miriam Butt and Sebastian Sulger (2008). "Urdu Ezafe and the Morphology-Syntax Interface". In Miriam Butt and Tracy Holloway King (Eds.), *Proceedings of the LFG08 Conference*, 129-149. CSLI Publications.
- Bosque, Ignacio and Carme Picallo (1996). "Postnominal adjectives in Spanish DPs". *Journal of Linguistics* 32: 349-385.
- Bouchard, Denis (1979). *Conjectures sur une grammaire indépendante du contexte pour les langues naturelles*. Unpublished MA dissertation, Université de Montréal.
- Bouchard, Denis (1984). *On the Content of Empty Categories*. Dordrecht: Foris Publications.
- Bouchard, Denis (1991). "From conceptual structure to syntactic structure". In Katherine Leffel and Denis Bouchard (Eds.) *Views on Phrase Structure*, 21-35. Dordrecht: Kluwer Academics.

REFERENCES

- Bouchard, Denis (1995). *The Semantics of Syntax*. Chicago: The University of Chicago Press.
- Bouchard, Denis (1997). "Optimal Parameters". In Alain Lecomte, Francois Lamarche, Guy Perrier (eds.), *Logical Aspects of Computational Linguistics*. 2nd Int. Conference, LACL '97, Nancy, France, September 22-24, 1997. Selected papers, Lecture Notes in Artificial Intelligence 1582.
- Bouchard, Denis (1998). "The distribution and interpretation of adjectives in French: A consequence of Bare Phrase Structure". *Probus* 10:139-183.
- Brody, Michael (1993). "θ-theory and arguments". *Linguistic Inquiry* 24: 1-23.
- Brody Michael (1994). "Phrase Structure and Dependence". *UCL Working Papers in Linguistics* 6: 1-33.
- Brody, Michael (1995). *Lexico-Logical Form: A radically minimalist theory*. Cambridge, Mass.: MIT Press.
- Brody, Michael (1997). "Mirror Theory". Ms. UCL.
- Burton-Roberts, Noel (1975). "Nominal apposition". *Foundations of Language* 13: 391-419.
- Campos, Héctor and Melita Stavrou (2004). "Polydefinite constructions in Modern Greek and in Aromanian". In *Balkan Syntax and Semantics*, ed. Olga M. Tomic, 137-173. Amsterdam.
- Carston, Robyn and D. Wilson (2007). "A unitary approach to lexical pragmatics: relevance, inference and ad hoc concepts". In N. Burton-Roberts (ed.) *Advances in Pragmatics*. 230-260. Palgrave.
- Chomsky, Noam (1994). "Bare Phrase Structure". *MIT Occasional Papers in Linguistics* 5.

REFERENCES

- Chomsky, Noam (1995). *The minimalist program*. Cambridge, Mass.: MIT Press.
- Cinque, Guglielmo (1993). "On the evidence for partial N-movement in the Romance DP". *University of Venice Working Papers in Linguistics* 3.2: 21-40.
- Cinque, Guglielmo (2005). "Deriving Greenberg's Universal 20 and Its Exceptions". *Linguistic Inquiry* 36.3: 315-332.
- Cormack, Annabel and Neil Smith (2000). "Fronting: The Syntax and Pragmatics of 'Focus' and 'Topic'". In Iten, C., Neeleman, A. (Eds.). *UCL Working Papers in Linguistics* 12: 387-417.
- Dehé, Nicole and Yordanka Kavalova (2007). "Parentheticals-An Introduction". *Ms. Freie Universiteit Berlin*.
- Dikken, Marcel den and Pornsiri Singhapreecha (2004). "Complex Noun Phrases and Linkers". *Syntax* 7: 1-24.
- Dixon, Robert (1982). *Where Have All the Adjectives Gone?* The Hague: Mouton.
- Espinal, T. (1991). "The representation of disjunct constituents". *Language* 64: 726-762.
- Flynn, Michael (1983). "A categorical theory of structure building". In Gerald Gazdar, Ewan Klein and Geoffrey Pullum (Eds.). *Order, Concord and Constituency* 139-174. Dordrecht: Foris Publications.
- Greenberg, Joseph (1963). "Some universals of grammar with particular reference to the order of meaningful elements". In *Universals of language*, Joseph Greenberg (eds.), 73-113. Cambridge, Mass.: MIT Press.
- Ghameshi, Jila (1997a). "Topics in Persian VPs". *Lingua* 102: 133-167.

REFERENCES

- Ghomeshi, Jila (1997b). "Non-projecting nouns and the Ezafe construction in Persian". *Natural Language and Linguistic Theory* 15(4): 729-788.
- Haider, Hubert and Ronald Zwanziger (1981). "Relatively attributive: The 'ezâfe'-construction from Old Iranian to Modern Persian. In Jacek Fisiak (Ed.), *Historical syntax*, 137-172. Berlin: Mouton.
- Heim, Irene and Angelika Kratzer (2005)⁷. *Semantics in Generative Grammar*. Blackwell Publishing.
- Higginbotham, James (1985). "On Semantics". *Linguistic Inquiry* 16: 547-593.
- Holmberg, Anders and David Odden (2005). "The noun phrase in Hawramani". Presented at *the First International Conference on Aspects of Iranian Linguistics*, Leipsig, June 2005.
- Kahnemuyipour, Arsalan (2000). "Persian Ezafe construction revisited: Evidence for modifier phrase". *The 2000 Annual Conference of the Canadian Linguistic Association*, 173-185.
- Kamp, Hans (1975). "Two theories about adjectives". In Edward L. Keenan (Ed.), *Formal Semantics of Natural Language* 123-155. Cambridge University Press.
- Kamp, Hans and Barbara Partee (1995). "Prototype theory and compositionality". *Cognition* 57: 129-191.
- Kariaeva, N. (2004a). "Determiner Spreading in Modern Greek: Split-DP Hypothesis". *Ms. Rutgers University*.
- Kariaeva, N. (2004b). Agreement and locality. *Ms. Rutgers University*.
- Kayne, Richard (1994). *The Antisymmetry of Syntax*. Cambridge, Mass.: MIT Press.

REFERENCES

- Keenan, Edward and Y. Stavi (1994). "A Semantic Characterization of Natural Language Determiners". *Linguistics and Philosophy* 9: 253-326.
- Keizer, M.E. (2005). "The discourse function of close appositions". *Neophilologus* 89: 447-467.
- Kent, Roland G. (1944). "The Old Persian relative and article". *Language* 20: 1-10.
- Kolliakou, Dimitra (1999). "Non-monotone anaphora and the syntax of definiteness". In Corblin, F., Dobrovie-Sorin, C. & Marandin, J.-M. (eds.), *Empirical issues in formal syntax and semantics 2: selected papers from the Colloque de Syntaxe et Semantique a Paris (CSSP 1997)*. The Hague: Thesus. 121-143.
- Kolliakou, Dimitra (2004). "Monadic definites and polydefinites". *Journal of Linguistics* 40: 263-333.
- L' Huillier, Monique (1999). *Advanced French Grammar*. Cambridge University Press.
- Laenzlinger, Christopher (2005). "French adjective ordering: perspectives on DP-internal movement types". *Lingua* 115: 645-689.
- Lance, Donald (1968). *Sequential ordering in prenominal modification in English: A critical review*. Ph.D. Dissertation, The University of Texas at Austin.
- Larson, Richard K. (1988). "On the double object construction. *Linguistic Inquiry* 19(3): 335-391.
- Larson, Richard K. (1998). "Events and modification in nominals". In D. Strolovitch and A. Lawson (eds.) *Proceedings from Semantics and Linguistic Theory (SALT) VIII*. Cornell University, Ithaca, NY.

REFERENCES

- Larson, Richard K. (2000) "Temporal modification in nominals". Handout of paper presented at the *International Round Table "The Syntax of Tense and Aspect"*, Paris, France (November 15-18, 2000).
- Larson, Richard K. and Hiroko Yamakido (2005). "Ezafe and the deep position of nominal modifiers". Presented at *the Barcelona Workshop on Adjectives and Adverbs*, March 2005.
- Larson, Richard K. and Hiroko Yamakido (2008). "Ezafe and the deep position of nominal modifiers". In L. McNally and C. Kennedy (Eds.) *Adjectives and adverbs. Syntax, Semantics and Discourse*, 43-70. Oxford: Oxford University Press.
- Lekakou, Marika and Kriszta Szendrői (2007). "Eliding the Noun in Close Apposition, or Greek Polydefinites Revisited". *UCL Working Papers in Linguistics* 19: 129-154.
- Leu, Tom (2007). "From Greek to Germanic: poly(*in)definites and weak/strong adjectival inflection". *Ms. New York University*.
- Manolessou, I. (2000). *Greek Noun Phrase Structure: A Study in Syntactic Evolution*. Ph.D. Dissertation. University of Cambridge.
- Marinis, Theodoros and Phoevos Panagiotidis (2004). "Determiner Spreading as referential predication". *Ms. Cyprus College*.
- Neeleman, Ad and Hans van de Koot (2002). "The Configurational Matrix". *Linguistic Inquiry* 33: 529-574.
- Neeleman, Ad and Hans van de Koot (2007). *Theta Theory. In Defence of Plan B*. Ms. UCL.

REFERENCES

- Neeleman, Ad and Hans van de Koot (2008). "Dutch scrambling and the nature of discourse templates". *Journal of Comparative Germanic Linguistics* 11: 137-189.
- Nichols, Johanna (1986). "Head-marking and dependent-marking grammar". *Language* 62: 56-119.
- Ntelitheos, Dimitris (2004). *Syntax of elliptical and discontinuous nominals*. MA Thesis, UCLA.
- Olivier, Jacqueline (1978). *Grammaire Française*. Harcourt Brace Jovanovich Publishers.
- Panagiotidis, Phoevos (2005). "Determiner spreading as DP-predication". *Ms. Cyprus College*.
- Pancheva, Marina (2007). "Everything I don't know about Ezafe". *DP Seminar*, CASTL, University of Tromsø.
- Partee, Barbara H. (1995). "Lexical Semantics and Compositionality". In Daniel Osherson, general editor *Invitation to Cognitive Science*, 2nd edition; in Part I: *Language*, Lila Gleitman and Mark Liberman (eds.), Cambridge, Mass.: MIT Press, 311-360.
- Potts, Christopher (2005). *The logic of conventional implicatures*. Oxford: OUP.
- Quirk, R., S. Greenbaum, G. Leech and J. Svartvik (1972). *A Grammar of Contemporary English*. London: Longman.
- Reinhart, Tanya. (1981). "Pragmatics and linguistics: an analysis of sentence topics". *Philosophica* 27: 53-94.
- Rizzi, Luigi (1997). "The fine structure of the left periphery". In Haegeman L. (Ed.), *Elements of Grammar*, Dordrecht, Kluwer.

REFERENCES

- Ruff, Joy Naomi (2009). "Locus and Linkers". Ms. UCL.
- Samiian, Vida (1983). *Origins of phrasal categories in Persian: An X-bar analysis*. Ph.D. Dissertation. UCLA.
- Samiian, Vida (1994). "The Ezafe construction: Some implications for the theory of X-bar syntax". In Medhi Marashi (Ed.), *Persian studies in North America*, 17-41. Bethesda, MD: Iranbooks.
- Samvelian, Pollet (2006). "When Morphology does better than Syntax: The Ezafe Construction in Persian". Ms Université de Paris 3.
- Samvelian, Pollet (2007). "A (phrasal) affix analysis of the Persian Ezafe". *Journal of Linguistics* 43: 605-645.
- Siegel, Muffy (1980). *Capturing the Adjective*. New York: Garland.
- Speas, Margaret (1986). *Adjunctions and projections in syntax*. Unpublished Ph.D. Dissertation, MIT.
- Sperber, Dan and D. Wilson (1998). "The mapping between the mental and the public lexicon". In P. Carruthers & J. Boucher (eds.) *Language and Thought*. Cambridge University Press, Cambridge: 184-200.
- Sproat, Richard and Chilin Shih (1988). "Prenominal Adjectival Ordering in English and Mandarin". *Proceedings of NELS* 12: 465-489.
- Sproat, Richard and Chilin Shih (1991). "The cross-linguistic distribution of adjective ordering restrictions". In Carol Georgopoulos and Roberta Ishihara (Eds.) *Interdisciplinary approaches to language*, 565-593. Kluwer, Dordrecht.
- Stavrou, Melita (1995). "Epexegetis vs. Apposition". *Scientific Yearbook of the Classics Dept.* Aristotle University of Thessaloniki.

REFERENCES

- Stump, Gregory (2001). *Inflectional Morphology*. Cambridge: Cambridge University Press.
- Szendrői, Kriszta (2010). "A flexible approach to discourse-related word order variations in the DP". *Lingua* 120: 864-878.
- Thompson, Michael (1997). "Position of Adjectives in Spanish". In <http://www.dur.ac.uk/m.p.thompson/adjectives.htm>, accessed 22/05/09. Durham University.
- Vallduví, E. and R. Zacharski (1993). "Accenting phenomena, association with focus, and the recursiveness of focus-ground". In Dekker, P. and M. Stokhof (Eds.), *Proceedings of the 9th Amsterdam Colloquium* 683-702. Amsterdam: ILLC (Institute for Logic, Language and Computation)/Department of Philosophy.
- Van de Koot, Hans (1994). "On the Status of the Projection Principle in the Minimalist Program". *UCL Working Papers in Linguistics* 6.
- Van Deemter, K. (1994). "What's new? A semantic perspective on sentence accent". *Journal of Semantics* II: 1-31.
- Vendler, Zeno (1968). *Adjectives and Nominalizations*. The Hague: Mouton.
- Waugh, Linda (1977). *A Semantic Analysis of Word Order*. Leiden: E.J. Brill.
- Whorf, Benjamin Lee (1945). "Grammatical categories". *Language* 21: 1-11.
- Williams, Edwin (1980). "Predication". *Linguistic Inquiry* 11: 203-238.
- Williams, Edwin (1984). "Grammatical Relations". *Linguistic Inquiry* 15: 639-673.
- Williams, Edwin (1989). "The Anaphoric Nature of θ -Roles". *Linguistic Inquiry* 20: 425-456.

