

This is the Author's Accepted Manuscript version of the article: Trompeter, N., Austen, E., Bussey, K., Reilly, E. E., Cunningham, M. L., Mond, J., Lonergan, A., Tame, J., & Mitchison, D. (2023). Examination of bidirectional relationships between fear of negative evaluation and weight/shape concerns over 3 years: A longitudinal cohort study of Australian adolescents. *International Journal of Eating Disorders*, 1–8. <https://doi.org/10.1002/eat.23881>

Examination of bi-directional relationships between fear of negative evaluation and weight/shape concerns over three years: A longitudinal cohort study of Australian adolescents

Author Affiliations:

Nora Trompeter*	(1) Centre for Emotional Health, School of Psychological Sciences, Macquarie University, Sydney, Australia
(corresponding author)	(2) Department of Psychological Medicine, King's College London
	Email: nora.trompeter@kcl.ac.uk
Emma Austen	Melbourne School of Psychological Sciences, University of Melbourne, Melbourne, Victoria, Australia
Kay Bussey	Centre for Emotional Health, School of Psychological Sciences, Macquarie University, Sydney, Australia

Erin E Reilly	Department of Psychiatry, University of California, San Francisco
Mitchell L Cunningham	School of Psychology, University of Sydney, Sydney, New South Wales, Australia
Jonathan Mond	Centre for Rural Health, University of Tasmania, Launceston, Australia; School of Medicine, Western Sydney University; Sydney Australia.
Alexandra Lonergan	Centre for Emotional Health, School of Psychological Sciences, Macquarie University, Sydney, Australia
Jack Tame	Centre for Emotional Health, School of Psychological Sciences, Macquarie University, Sydney, Australia
Deborah Mitchison	Translational Health Research Institute, School of Medicine, Western Sydney University, Sydney, Australia; Centre for Emotional Health, School of Psychological Sciences, Macquarie University, Sydney, Australia

Conflicts of Interest/Disclosures:

Nora Trompeter was supported by an Australian Government Research Training Program Scholarship for the duration of this project. This study was funded by a Macquarie University Research Fellowship and National Health and Medical Research Council Early Career Fellowship awarded to Dr. Deborah Mitchison (grant number 1158276).

Data availability Statement:

Deidentified data are available upon request from the senior author (D.M.), pertaining to approval from the authors' institutional ethics committee.

Authors' contributions:

Nora Trompeter: Conceptualization, Formal analysis, Investigation, Writing - Original Draft, Project administration; **Emma Austen:** Formal analysis, Writing - Review & Editing; **Kay Bussey:** Conceptualization, Methodology, Writing - Review & Editing, Supervision; **Erin E Reilly:** Conceptualization, Writing - Review & Editing; **Mitchell L Cunningham:** Conceptualization, Writing - Review & Editing; **Jonathan Mond:** Methodology, Writing - Review & Editing; **Alexandra Lonergan:** Methodology, Writing - Review & Editing; **Jack Tame:** Project administration, Writing - Review & Editing; **Deborah Mitchison:** Conceptualization, Methodology, Writing - Review & Editing, Supervision, Project administration, Funding acquisition.

Word count (excluding tables, figures, and reference list): 3790

Abstract

Objective: Adolescents commonly experience both fear of negative evaluation and weight/shape concerns. However, evidence concerning the prospective associations between these constructs during adolescence is limited. The current study examined the bi-directional relationships between fear of negative evaluation and weight/shape concerns over a three-year period in adolescents. **Method:** Australian high school students ($n = 2073$; 55% girls) completed self-report measures at three timepoints, each one year apart. **Results:** Findings showed a bi-directional relationship, whereby increases in fear of negative evaluation predicted exacerbated weight/shape concerns, and vice versa. Results point towards a vicious maintenance cycle between fear of negative evaluation and weight/shape concerns. **Discussion:** Findings from the current study highlight the importance of considering both fear of negative evaluation and weight/shape concerns in the development of health promotion and prevention programs designed to reduce the occurrence and adverse effects of body dissatisfaction or improve general mental health.

Keywords: Fear of negative evaluation; Weight and shape concerns; Eating disorders; Social anxiety; Adolescence

Public significance statement:

Many adolescents experience some level of fear of negative evaluation (i.e., worry about being judged by others) and worry about their weight and/or shape. This study examined the prospective relationship between both constructs. Findings showed a bi-directional relationship, whereby higher fear of negative evaluation predicted increased weight/shape concerns, and vice versa. Programs designed to reduce body dissatisfaction might be improved by targeting both fear of negative evaluation and weight/shape concerns.

Examination of bi-directional relationships between fear of negative evaluation and weight/shape concerns over three years: A longitudinal cohort study of Australian adolescents

Both fear of negative evaluation and weight/shape concerns are commonly experienced by adolescents (Aune et al., 2022; Hughes et al., 2019). Apprehension and an expectation of being negatively evaluated by others (i.e., fear of negative evaluation) and undue worry about one's weight and body shape, as well as the perceived importance of weight/body shape to one's sense of self-worth (i.e., weight/shape concern) have been associated with high levels of distress (Fehm et al., 2008; Griffiths et al., 2017), and at extreme levels, represent core features of clinical psychological disorders (e.g., eating disorder and social anxiety disorder) (Fairburn et al., 2003; Rapee & Heimberg, 1997). Recent cross-sectional research showed that fear of negative evaluation is associated with weight/shape concerns among both adolescent boys and girls (Trompeter et al., 2018). However, our understanding of the temporal association between these constructs, namely whether fear of negative evaluation precedes weight/shape concerns among adolescents, or vice versa, remains to be examined. Clarifying this temporal association may have implications for health promotion and prevention programs targeting adolescents with weight/shape concerns. The current study sought to address this issue by investigating the longitudinal bi-directional relationships between these constructs among adolescents over a 3-year period.

Previous research among adults generally supports a robust link between fear of negative evaluation and constructs related to weight/shape concerns, such as thin internalisation (Maraldo et al., 2016) and body dissatisfaction (DeBoer et al., 2013). Further evidence suggests that fear of negative evaluation can account for the link between social anxiety and body dissatisfaction and drive for thinness respectively (Menatti et al., 2015).

Indeed, fear of negative evaluation has been proposed as an additional factor explaining body dissatisfaction within a revised version of the dual-pathway model for bulimia nervosa (Utschig et al., 2010). The dual-pathway model for bulimia nervosa proposes that bulimic behaviours occur due to increased dieting and increased negative affect (Stice & van Ryzin, 2019). Importantly, the model posits that internalization of the thin ideal (i.e., adopting the view that ideal bodies should be thin) and societal pressure to be thin lead to both increased dieting and increased negative affect. In their revised model, Utschig et al. (2010) found that the addition of fear of negative evaluation to the model improved the variance in bulimic behaviours accounted for by the model (the revised model accounted for 49% of variance compared to 32% in the original model). In particular, fear of negative evaluation was directly linked with societal pressure to be thin, internalization of the thin ideal, negative affect, and bulimic behaviours in their cross-sectional model. Thus, there is converging empirical and theoretical evidence positioning fear of negative evaluation as a risk factor for weight/shape concerns. However, most of the research to date has been conducted in adult samples. Notably, adolescence is a key developmental period for the development of socio-emotional disorders, which includes both eating disorders and social anxiety disorder (Rapee et al., 2019). As such, understanding the relationship between fear of negative evaluation and weight/shape concerns during this developmental period is key for developing effective health promotion and prevention programs aimed at reducing negative body image among adolescents.

In previous cross-sectional research, we found a significant positive association between fear of negative evaluation and weight/shape concerns among both adolescent boys and girls (Trompeter et al., 2018), suggesting that fear of negative evaluation could be a potential target in health promotion and prevention programs aimed at improving body image. Such programs frequently target related constructs, most notably self-esteem (Yager

et al., 2013), but not fear of negative evaluation itself. In particular, self-esteem refers to the self-evaluation of oneself, whereas fear of negative evaluation is concerned with others' evaluation of the self (Kocovski & Endler, 2000). Thus, if fear of negative evaluation predicts weight/shape concerns in adolescents, it may be beneficial for universal prevention programs to focus on both evaluation from oneself *and* others.

Whilst most work to date suggests that fear of negative evaluation precedes weight/shape concerns, few studies have investigated a potential bi-directional link between fear of negative evaluation and weight/shape concerns, with most research positioning fear of negative evaluation as a risk factor for weight/shape concerns, but not vice versa. It is, however, important to also consider that weight/shape concerns may predict fear of negative evaluation. Fear of negative evaluation is thought to stem from cognitive distortions by which individuals overestimate negative evaluations from others (Rapee & Spence, 2004). Such cognitive distortions are similar to those encapsulating weight/shape concerns (e.g., overvaluation of weight/shape). As such, experiencing cognitive distortions relating to weight/shape concerns may make individuals more likely to also develop cognitive distortions regarding other's evaluation of themselves. Importantly, if weight/shape concerns and fear of negative evaluation are bi-directionally linked, an integrated program that target both weight/shape concerns and fear of negative evaluation may be beneficial for reducing the occurrence and adverse impact of both constructs and improve the overall mental health of adolescents, rather than solely focusing on the impact of body image. Of the limited longitudinal research examining this potential bi-directional relationship, DeBoer et al. (2013) found that among adult women who had completed a body image intervention program, fear of negative evaluation and body dissatisfaction were reciprocally linked after 6 and 12 months. However, similar research has yet to be conducted among adolescents and no data is available on mixed-gender or male samples.

Our previous cross-sectional research indicates potential gender differences in the relationship between fear of negative evaluation and weight/shape concerns, whereby this relationship was stronger among girls compared to boys (Trompeter et al., 2018). Similarly, a study by Cook-Cottone et al. (2016) found that a mediating effect of social anxiety, when linking peer victimization and eating disorder symptoms in adolescents, was significantly greater for girls compared to boys. One potential explanation for these gender differences may be the link between appearance and self-image in adolescents. Previous research suggests that self-image in adolescent girls is more likely to be determined by appearance compared to adolescent boys (Forsén Mantilla et al., 2014; Golan et al., 2014). Thus, fear of negatively evaluation might be more likely to elicit concerns about appearance among girls compared to boys, given the relative value placed on appearance. However, we currently lack an understanding of how such gender differences manifest longitudinally. This knowledge will be critical in informing body image intervention strategies, as current intervention programs have been found to be less effective among adolescent boys compared to adolescent girls (Chua et al., 2020; Zuair & Sopory, 2022).

To address these critical gaps, the current study investigated the longitudinal bi-directional relationship between fear of negative evaluation and weight/shape concerns among adolescents over a 3-year period. Specifically, it was hypothesized that higher average levels of fear of negative evaluation would predict higher average weight/shape concerns at the subsequent time point. No a-priori hypotheses were made regarding the impact of weight/shape concerns on fear of negative evaluation due to limited existing research. Moreover, the current study examined whether this relationship was consistent for both adolescent boys and girls.

Methods

Participants and procedure

This study used longitudinal data from the first (T1), second (T2) and third waves (T3) of the EveryBODY study, a large longitudinal project investigating body image and eating disorders among Australian adolescents. Data were collected in 2017, 2018, and 2019 respectively with approximately 12 months between each data collection point. The project was a school-based survey among high school students, whereby all students in years 7-12 were invited to participate in the yearly survey (see Trompeter et al., 2018 for full study methodology). Schools were representative of the Australian average in terms of socio-economic status (SES). The Index of Community Socio-Educational Advantage (ICSEA) is a standardized ($M = 1000$, $SD = 100$) measure of educational advantage based on parental occupation and education, geographic location and proportion of Indigenous enrolments that is assigned to each school. ICSEA scores of schools in the overall sample of the EveryBODY study ranged from 909 to 1129 ($M = 1035$, $SD = 60.91$).

For the current study, we initially planned to include all participants enrolled in years 7-10 at T1 who had completed measures at T1 ($n = 4216$). Of these, 207 participants were excluded due to non-serious responses (i.e., bogus or inappropriate responses to open-ended questions), at one of more waves. This final sample comprised 4009 adolescents. However, due to missing data further participants were excluded (for details of these exclusions, see *Missing data*). Thus, the final analytic sample ($n = 2073$) included 924 boys (44.6%), 1140 girls (55.0%) and 9 non-binary participants (0.4%). Most participants (89.9%) were born in Australia and 5.1% identified as Aboriginal and/or Torres Strait Islander. Sample characteristics are shown in Table 1.

Table 1. *Sample characteristics. Values are presented as mean (standard deviation)*

	Time 1	Time 2	Time 3
Age in years	13.8 (1.2)	14.7 (1.5)	15.8 (1.1)
BMI percentile	51.8 (30.9)	52.8 (30.3)	54.0 (29.9)
Weight/shape concerns	1.6 (1.8)	1.7 (1.8)	1.9 (1.8)
Fear of negative evaluation	17.4 (9.5)	18.4 (9.7)	19.2 (9.3)

Note. BMI = Body mass index. BMI percentiles were calculated in line with the CDC guidelines to account for age and gender.

Measures

Fear of negative evaluation. Participants' fear of negative evaluation was measured using the eight positively-worded items from the Brief Fear of Negative Evaluation (BFNE) scale (Leary, 1983). The scale assessed adolescent's concern about others' evaluations, distress associated with such negative evaluations, and expectancy of other's negative evaluations. Participants rated each item (e.g., "I am afraid others will not approve of me") on a 5-point response scale (1 = *Not at all* to 5 = *Extremely*). Responses were summed to produce a total score (range: 8-40), with higher scores indicative of a greater fear of negative evaluation. The scale has shown good internal reliability in adolescents (Geukens et al., 2020) and has been found to have better psychometric properties compared to the full scale (Carleton et al., 2007; Rodebaugh et al., 2004). The scale demonstrated excellent internal consistency in the current study for all time points (T1: Cronbach's $\alpha = .97$, McDonald's $\omega = .97$; T2: Cronbach's $\alpha = .97$, McDonald's $\omega = .97$; T3: Cronbach's $\alpha = .97$, McDonald's $\omega = .97$).

Weight/Shape Concerns. Participants' weight/shape concerns were assessed using 12 items of the combined weight and shape concerns subscale of the Eating Disorder

Examination Questionnaire (EDE-Q; Fairburn et al. 2008). The EDE-Q assesses eating disorder pathology over the past month. Participants rate the frequency/severity of their weight and shape concerns in the past 28 days (e.g., “How dissatisfied have you been with your weight”) on a 7-point response scale (0 = *No days/Not at all* to 6 = *Everyday/Markedly*). A mean score of items is calculated with higher scores indicative of greater severity of weight and shape concerns. The subscale has demonstrated good reliability among Australian adolescent boys and girls (Mond et al. 2014). The scale demonstrated excellent internal consistency in the current study for all time points (T1: Cronbach’s $\alpha = .96$, McDonald’s $\omega = .96$; T2: Cronbach’s $\alpha = .97$, McDonald’s $\omega = .96$; T3: Cronbach’s $\alpha = .96$, McDonald’s $\omega = .96$).

Demographic information

Participants were asked to self-report demographic information such as gender, age, and weight and height, which were used to determine body mass index (BMI) percentiles in line with the CDC guidelines (Centers for Disease Control and Prevention, 2017).

Missing data

There was notable drop-out after T1 due to five schools discontinuing with the project. The final dataset contained 1936 participants with T1 data only (48.3%), 1055 participants with two waves completed (26.3%) and 1018 participants with all three waves completed (25.4%). One-way ANOVAs with Tukey post-hoc tests were conducted to examine potential differences in participants’ demographics at baseline by wave completion. There was a significant difference in age ($F(2,3990) = 22.05, p < .001$), whereby participants who completed only T1 were significantly younger compared to those who completed T1 and either T2 or T3 ($p = .021$) or all three waves ($p < .001$). Participants who had completed T1 and either T2 or T3 were also significantly younger than those who completed all three waves

($p = .001$). Further, there was a significant difference in BMI percentile ($F(2,3711) = 7.36, p = .001$), whereby participants who completed only T1 had a significantly higher BMI percentile compared to those who completed all three waves ($p < .001$). Lastly, there was a significant difference in weight/shape concerns ($F(2,3926) = 4.29, p = .014$), whereby participants who completed all three wave had a significantly lower weight/shape concerns compared to those who completed only T1 ($p = .025$) or T1 and either T2 or T3 ($p = .026$). No differences were detected in fear of negative evaluation, $F(2,3450) = 0.97, p = .379$. However, effect sizes of these differences were weak ($\eta^2 < 0.01$).

Due to high drop-out and differences observed in the participants who completed only one wave, compared to those who completed multiple waves, we decided to only include participants in the data analysis who had completed T1 and at least one of the follow-up waves (T2 or T3; $n = 2073$). To account for factors linked with drop-out, age and BMI percentile were controlled for in the analyses. In the final dataset issues with missing data were observed, whereby missingness in the weight/shape concerns score at T2 was explained by an outcome variable (weight/shape concerns at T3). Thus, the assumption of missingness at random was violated.

Data analytic plan

The analysis plan was preregistered on the Open Science Framework (https://osf.io/vdf7j/?view_only=30b6e74d66b1412c90cebbbe4c66a954). All deviations from the a priori analytic plan are explicitly mentioned below. Prior to examining the analyses, the potential clustering effect of schools was assessed using mixed model analysis with school as a random factor for each timepoint. The random factor was not significant, and school was not controlled for in any subsequent analyses.

We had initially planned to run a Random Intercept Cross-Lagged Panel Model (RI-CLPM), which distinguishes stable between-subject effects from temporal within-subject effects (Hamaker et al., 2015). Further detail on the planned RI-CLPM model is available in the pre-registration. However, model fit indices of the planned RI-CLPM model showed that the data were poor fit (CFI = .51; TLI = .54; RMSEA = .22). Post-hoc power analysis using a Monte Carlo simulation (Masselink et al., 2018) showed that we had insufficient power (<.80%) to detect cross-lagged effects from weight/shape concerns to fear of negative evaluation. As such, a traditional cross-lagged panel model was run instead (see Figure 1), because, relative to RI-CLPMs, these models contain fewer parameters and thus require smaller samples sizes to achieve adequate statistical power.

Figure 1. *Proposed cross-lagged panel model.*

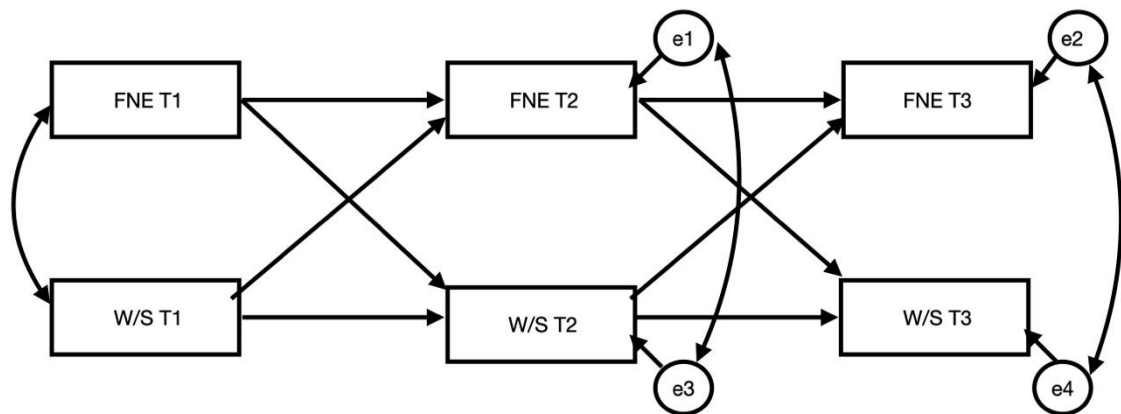

Note. FNE = fear of negative evaluation; W/S = weight/shape concerns.

Cross-lagged panel models consists of both autoregressive paths (paths over time between the same constructs), and cross-lagged paths (paths over time between two different constructs). Thus, the autoregressive paths are examined for stability of a construct, whereas the cross-lagged paths are used to examine the prospective association between two constructs controlling for stability in both constructs. As such, this model tests change in individual differences of a construct (Orth et al., 2021).

In line with our pre-registered analysis, the strength of both the cross-lagged and auto-regressive pathways were constrained to be equal across all timepoints, given that there is no theoretical rationale to expect that associations would differ in strength over time, and the intervals between timepoints were designed to be approximately equal. Analyses were conducted in Mplus (Muthén & Muthén, 2018) using full information maximum likelihood to handle missing data and potential non-normal distribution of the data. All variables were centred using their grand mean. Standardized regression coefficients and 95% confidence intervals are reported.

Model fit was examined using the Comparative Fit Index (CFI), Tucker Lewis Index (TLI), and Root Mean Square Error of Approximation (RMSEA). In line with Vandenberg and Lance (2000), CFI and TLI were examined at .90 and RMSEA at less than .08.

Finally, multi-group analyses were used to determine whether the estimated model differed between boys and girls. Due to the small number of non-binary participants, these were excluded from the multi-group analysis. To examine gender differences, all associations were constrained between groups, and the overall difference between boys and girls in model fit was tested using a Wald-test. Post-hoc power analysis using G*Power (Faul et al., 2007) to estimate the statistical power of the Wald test indicated sufficient power (>80%) to detect differences between the two groups.

Results

Correlations

Table 2 shows correlations between the study variables. Both constructs were strongly correlated over time and showed strong stability across waves.

Table 2. *Spearman correlations of all variables*

	1	2	3	4	5	6
1. Fear of negative evaluation T1	-					
2. Fear of negative evaluation T2	.57*	-				
3. Fear of negative evaluation T3	.50*	.63*	-			
4. Weight/shape concerns T1	.65*	.48*	.42*	-		
5. Weight/shape concerns T2	.52*	.67*	.51*	.69*	-	
6. Weight/shape concerns T3	.46*	.53*	.62*	.75*	.62*	-

Note. * $p < .001$

Cross-lagged panel model

The proposed model (Figure 1) demonstrated good fit (CFI = .96, TLI = .93, RMSEA = .04). Fear of negative evaluation predicted increased weight/shape concerns over time (T1 to T2: $B = .06$ [.02, .10], $p = .002$; T2 to T3: $B = .06$ [.02, .10], $p = .002$). This effect was reciprocal, with weight/shape concerns also predicting increased fear of negative evaluation (T1 to T2: $B = .14$ [.10, .19], $p < .001$; T2 to T3: $B = .15$ [.10, .19], $p < .001$).

Figure 2. *Cross-lagged panel model entire sample. Standardized regression coefficients are reported.*

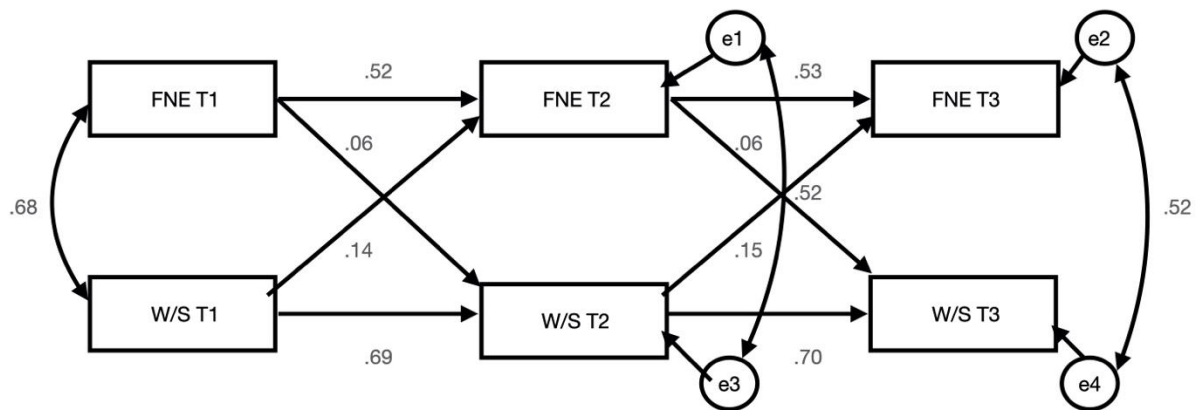

Note. All paths are significant at $p < .001$. FNE = fear of negative evaluation; W/S = weight/shape concerns. Analyses adjusted for age and BMI percentile at T1.

Lastly, gender differences in the above associations were tested using a multi-group analysis. Findings showed that the above associations did not significantly between boys and girls ($\chi^2(11) = 18.73, p = .066$). Results can therefore be interpreted for boys and girls combined.

Discussion

The current study examined the bidirectional relationship between fear of negative evaluation and weight/shape concerns during adolescence. Findings provided evidence for a bidirectional relationship, with fear of negative evaluation predicting increases in weight/shape concerns one year later, and weight/shape concerns predicting increases in fear of negative evaluation after one year. Notably, these associations did not differ between girls and boys.

These findings extend previous cross-sectional research on fear of negative evaluation (Anderson et al., 2020; MacKey & la Greca, 2008; Trompeter et al., 2018) to suggest that fear of negative evaluation may predict subsequent weight/shape concerns in adolescents. While the

mechanisms through which this longitudinal relationship may operate cannot be ascertained in the current study, fear of negative evaluation has been shown to make individuals more attentive to potential social threats (Rossignol et al., 2013). Concerns about social threats may result in individuals with high levels of fear of negative evaluation more likely to seek to conform to demanding sociocultural appearance standards such as the thin and muscular ideals. This may in turn elicit weight/shape concerns, particularly when discrepancies between these ideals and one's current body shape or size is perceived. These possibilities should be directly explored in future research.

Of note, weight/shape concerns also predicted increased fear of negative evaluation among adolescents. Few studies to date have examined how weight/shape concerns may impact subsequent fear of negative evaluation. Since fear of negative evaluation is a core component of social anxiety disorder, and since there is good evidence that anxiety disorders often precede eating disorders, research has tended to focus on the path from fear of negative evaluation to weight/shape concerns (Swinbourne & Touyz, 2007). However, the current findings are consistent with the possibility that both fear of negative evaluation and weight/shape concerns maintain each other, thus fear of negative evaluation may be exacerbated by co-occurring weight/shape concerns. While few studies to date have examined the bi-directional link between fear of negative evaluation and weight/shape concerns, related research has indicated that eating disorders may also predict later anxiety disorders in adulthood (Buckner et al., 2010; Micali et al., 2015). This may be attributable to the social avoidance commonly associated with heightened weight/shape concerns (Mills et al., 2014), which is a key maintenance factor of social anxiety (Miers et al., 2014). Notably, bigger effect sizes were observed when looking at weight/shape concerns predicting fear of negative evaluation than vice versa. These findings suggest that more attention should be paid

to the bi-directional relationship of these constructs, rather than positioning fear of negative evaluation solely as a predictor of weight/shape concerns.

Future research should clarify whether both fear of negative evaluation and weight/shape concerns are truly both predictors of one another, such that weight/shape concerns can occur independently and give rise to fear of negative evaluation, or whether they are only reciprocal once fear of negative evaluation is already present. Future studies may want to examine these associations in children prior to adolescence to capture these constructs closer to their onset and to disentangle the relationships further.

The current study has important implications for health promotion and prevention programs seeking to reduce the occurrence and adverse effects of body dissatisfaction and eating-disordered behavior. Notably, as fear of negative evaluation and weight/shape concerns typically increase as children enter adolescence (Bucchianeri et al., 2013; Westenberg et al., 2007), programs aimed at reducing body image concerns among adolescents could target these factors. Current prevention programs for body image concerns frequently target self-esteem (Yager et al., 2013), but could be extended to target fear of negative evaluation to increase effectiveness. To the authors knowledge, fear of negative evaluation has not, thus far, been targeted in prevention programs for body image concerns or eating disorders. Health promotion programs for body dissatisfaction and eating-disordered behavior have been somewhat neglected in the eating disorders field thus far, but arguably are an important component of overall efforts to reduce the occurrence and adverse effects of body dissatisfaction and eating-disordered behavior (see Bullivant et al., 2020). Further, the findings regarding the bi-directional association between fear of negative evaluation and weight/shape concerns suggest that integrated prevention programs that targets both fear of negative evaluation and weight/shape concerns may be beneficial in reducing the occurrence

and adverse impact of both constructs and consequently improve the overall mental health of adolescents.

While the current study had several strengths, including the three-year longitudinal design and representative community sample, several limitations should be acknowledged. Firstly, while we had planned to conduct a RI-CLPM, which separates the within-person and between-person variance, this was not possible due to insufficient statistical power. While the current study suggests that adolescents with high fear of negative evaluation (compared to others) are at risk for increased weight/shape concerns (and vice versa; a between-person relationship), it is unclear whether adolescents who experience higher levels of fear of negative evaluation *than they themselves would usually experience* are at similar risk of increased weight/shape concerns (i.e., a within-person relationship). Future research should aim to examine this line of research using a RI-CLPM in a larger sample. Secondly, the current study could not determine causality. Future research would benefit from further experimental or intervention research to determine whether decreases in fear of negative evaluation reduce weight/shape concerns and vice versa. Lastly, issues with missing data were observed in the current study. Most notably, the assumption of missingness at random was violated. To deal with issues related to drop-out we decided to only include participants who completed at least one follow-up assessment (T2 or T3) and adjusted for factors associated with dropout (i.e., age and BMI percentile) in the analysis. However, replication of the findings is needed in light of these issues.

In conclusion, the current study suggests a bi-directional relationship between fear of negative evaluation and weight/shape concerns in adolescence. Findings have implications for the development of health promotion and prevention programs seeking to reduce the occurrence and adverse impacts of body dissatisfaction in young people. Future research

should examine whether targeting fear of negative evaluation in adolescents is effective in reducing weight/shape concerns and vice versa.

References

- Anderson, L. M., Wong, N., Lanciers, S., & Lim, C. S. (2020). The relative importance of social anxiety facets on disordered eating in pediatric obesity. *Eating and Weight Disorders, 25*, 117–126. <https://doi.org/10.1007/s40519-018-0526-x>
- Aune, T., Nordahl, H. M., & Beidel, D. C. (2022). Social anxiety disorder in adolescents: Prevalence and subtypes in the Young-HUNT3 study. *Journal of Anxiety Disorders, 87*, 102546. <https://doi.org/10.1016/j.janxdis.2022.102546>
- Bucchianeri, M. M., Arikian, A. J., Hannan, P. J., Eisenberg, M. E., & Neumark-Sztainer, D. (2013). Body dissatisfaction from adolescence to young adulthood: Findings from a 10-year longitudinal study. *Body Image, 10*(1), 1–7. <https://doi.org/10.1016/j.bodyim.2012.09.001>
- Buckner, J. D., Silgado, J., & Lewinsohn, P. M. (2010). Delineation of differential temporal relations between specific eating and anxiety disorders. *Journal of Psychiatric Research, 44*(12), 781–787. <https://doi.org/10.1016/j.jpsychires.2010.01.014>
- Bullivant, B., Rhydderch, S., Griffiths, S., Mitchison, D., & Mond, J. (2020). Eating disorders “mental health literacy”: a scoping review. *Journal of Mental Health, 29*(3), 336–349. <https://doi.org/10.1080/09638237.2020.1713996>
- Centers for Disease Control and Prevention. (2017). *About Child & Teen BMI*.
- Chua, J. Y. X., Tam, W., & Shorey, S. (2020). Research Review: Effectiveness of universal eating disorder prevention interventions in improving body image among children: a systematic review and meta-analysis. *Journal of Child Psychology and Psychiatry, 61*(5), 522–535. <https://doi.org/10.1111/jcpp.13164>
- Cook-Cottone, C., Serwacki, M., Guyker, W., Sodano, S., Nickerson, A., Keddie-Olka, E., & Anderson, L. (2016). The Role of Anxiety on the Experience of Peer Victimization and Eating Disorder Risk. *School Mental Health, 8*(3), 354–367. <https://doi.org/10.1007/s12310-016-9178-z>
- DeBoer, L. B., Medina, J. L., Davis, M. L., Presnell, K. E., Powers, M. B., & Smits, J. A. J. (2013). Associations between fear of negative evaluation and eating pathology during intervention and 12-month follow-up. *Cognitive Therapy and Research, 37*(5), 941–952. <https://doi.org/10.1007/s10608-013-9547-y>
- Fairburn, C. G., Cooper, Z., & Shafran, R. (2003). Cognitive behaviour therapy for eating disorders: A “transdiagnostic” theory and treatment. *Behaviour Research and Therapy, 41*(5), 509–528. [https://doi.org/10.1016/S0005-7967\(02\)00088-8](https://doi.org/10.1016/S0005-7967(02)00088-8)
- Faul, F., Erdfelder, E., Lang, A.-G., & Buchner, A. (2007). G*Power 3: A flexible statistical power analysis program for the social, behavioral, and biomedical sciences. *Behavior Research Methods, 39*(2), 175–191. <https://doi.org/10.3758/BF03193146>
- Fehm, L., Beesdo, K., Jacobi, F., & Fiedler, A. (2008). Social anxiety disorder above and below the diagnostic threshold: Prevalence, comorbidity and impairment in the general population. *Social Psychiatry and Psychiatric Epidemiology, 43*(4), 257–265. <https://doi.org/10.1007/s00127-007-0299-4>

- Forsén Mantilla, E., Bergsten, K., & Birgegård, A. (2014). Self-image and eating disorder symptoms in normal and clinical adolescents. *Eating Behaviors, 15*(1), 125–131. <https://doi.org/10.1016/j.eatbeh.2013.11.008>
- Godart, N. T., Flament, M. F., Curt, F., Perdereau, F., Lang, F., Venisse, J. L., Halfon, O., Bizouard, P., Loas, G., Corcos, M., Jeammet, P., & Fermanian, J. (2003). Anxiety disorders in subjects seeking treatment for eating disorders: A DSM-IV controlled study. *Psychiatry Research, 117*(3), 245–258. [https://doi.org/10.1016/S0165-1781\(03\)00038-6](https://doi.org/10.1016/S0165-1781(03)00038-6)
- Godart, N. T., Flament, M. F., Lecrubier, Y., & Jeammet, P. (2000). Anxiety disorders in anorexia nervosa and bulimia nervosa: Co-morbidity and chronology of appearance. *European Psychiatry, 15*(1), 38–45. [https://doi.org/10.1016/S0924-9338\(00\)00212-1](https://doi.org/10.1016/S0924-9338(00)00212-1)
- Golan, M., Hagay, N., & Tamir, S. (2014). Gender related differences in response to “In favor of myself” wellness program to enhance positive self & body image among adolescents. *PLoS ONE, 9*(3), e91778-. <https://doi.org/10.1371/journal.pone.0091778>
- Griffiths, S., Murray, S. B., Bentley, C., Gratwick-Sarll, K., Harrison, C., & Mond, J. (2017). Sex Differences in Quality of Life Impairment Associated With Body Dissatisfaction in Adolescents. *Journal of Adolescent Health, 61*(1), 77–82. <https://doi.org/10.1016/j.jadohealth.2017.01.016>
- Hamaker, E. L., Kuiper, R. M., & Grasman, R. P. P. P. (2015). A critique of the cross-lagged panel model. *Psychological Methods, 20*(1), 102–116. <https://doi.org/10.1037/a0038889>
- Hughes, E. K., Kerr, J. A., Patton, G. C., Sawyer, S. M., Wake, M., le Grange, D., & Azzopardi, P. (2019). Eating disorder symptoms across the weight spectrum in Australian adolescents. *International Journal of Eating Disorders, 52*(8), 885–894. <https://doi.org/10.1002/eat.23118>
- Kocovski, N. L., & Endler, N. S. (2000). Social anxiety, self-regulation, and fear of negative evaluation. *European Journal of Personality, 14*(4), 347–358. [https://doi.org/10.1002/1099-0984\(200007/08\)14:4<347::AID-PER381>3.0.CO;2-7](https://doi.org/10.1002/1099-0984(200007/08)14:4<347::AID-PER381>3.0.CO;2-7)
- MacKey, E. R., & la Greca, A. M. (2008). Does this make me look fat? Peer crowd and peer contributions to adolescent girls’ weight control behaviors. *Journal of Youth and Adolescence, 37*(1), 1–12. <https://doi.org/10.1007/s10964-008-9299-2>
- Maraldo, T. M., Zhou, W., Dowling, J., & vander Wal, J. S. (2016). Replication and extension of the dual pathway model of disordered eating: The role of fear of negative evaluation, suggestibility, rumination, and self-compassion. *Eating Behaviors, 23*, 187–194. <https://doi.org/10.1016/j.eatbeh.2016.10.008>
- Masselink, M., Van Roekel, E., Hankin, B. L., Keijsers, L., Lodder, G. M. A., Vanhalst, J., Verhagen, M., Young, J. F., & Oldehinkel, A. J. (2018). The Longitudinal Association between Self-Esteem and Depressive Symptoms in Adolescents: Separating Between-Person Effects from Within-Person Effects. *European Journal of Personality, 32*(6), 653–671. <https://doi.org/10.1002/per.2179>
- Menatti, A. R., DeBoer, L. B., Weeks, J. W., & Heimberg, R. G. (2015). Social anxiety and associations with eating psychopathology: Mediating effects of fears of evaluation. *Body Image, 14*, 20–28. <https://doi.org/10.1016/j.bodyim.2015.02.003>
- Micali, N., Solmi, F., Horton, N. J., Crosby, R. D., Eddy, K. T., Calzo, J. P., Sonnevile, K. R., Swanson, S. A., & Field, A. E. (2015). Adolescent Eating Disorders Predict Psychiatric, High-Risk Behaviors and Weight Outcomes in Young Adulthood. *Journal of the American Academy of Child & Adolescent Psychiatry, 54*(10), 953–961. <https://doi.org/10.1097/00004583-201510000-00011>

- Adolescent Psychiatry*, 54(8), 652–659.e1.
<https://doi.org/https://doi.org/10.1016/j.jaac.2015.05.009>
- Miers, A. C., Blöte, A. W., Heyne, D. A., & Westenberg, P. M. (2014). Developmental pathways of social avoidance across adolescence: THE role of social anxiety and negative cognition. *Journal of Anxiety Disorders*, 28(8), 787–794. <https://doi.org/10.1016/j.janxdis.2014.09.008>
- Mills, J., Fuller-Tyszkiewicz, M., & Holmes, M. (2014). State Body Dissatisfaction and Social Interactions: An Experience Sampling Study. *Psychology of Women Quarterly*, 38(4), 551–562. <https://doi.org/10.1177/0361684314521139>
- Muthén, L. K., & Muthén, B. O. (2018). *Mplus user's guide* (8th ed.). Muthén & Muthén.
- Orth, U., Clark, D. A., Donnellan, M. B., & Robins, R. W. (2021). Testing prospective effects in longitudinal research: Comparing seven competing cross-lagged models. *Journal of Personality and Social Psychology*, 120(4), 1013–1034. <https://doi.org/10.1037/pspp0000358>
- Rapee, R. M., & Heimberg, R. G. (1997). A cognitive-behavioral model of social phobia. *Behaviour Research and Therapy*, 35(8), 741–756.
- Rapee, R. M., Oar, E. L., Johnco, C. J., Forbes, M. K., Fardouly, J., Magson, N. R., & Richardson, C. E. (2019). Adolescent development and risk for the onset of social-emotional disorders: A review and conceptual model. *Behaviour Research and Therapy*, 123, 103501. <https://doi.org/10.1016/j.brat.2019.103501>
- Rapee, R. M., & Spence, S. H. (2004). The etiology of social phobia: empirical evidence and an initial model. *Clinical Psychology Review*, 24(7), 737–767. <https://doi.org/10.1016/j.cpr.2004.06.004>
- Rossignol, M., Campanella, S., Bissot, C., & Philippot, P. (2013). Fear of negative evaluation and attentional bias for facial expressions: An event-related study. *Brain and Cognition*, 82(3), 344–352. <https://doi.org/https://doi.org/10.1016/j.bandc.2013.05.008>
- Stice, E., & van Ryzin, M. J. (2019). A Prospective test of the temporal sequencing of risk factor emergence in the dual pathway model of eating disorders. *Journal of Abnormal Psychology*, 128(2), 119–128. <https://doi.org/10.1037/abn0000400>
- Swinbourne, J. M., & Touyz, S. (2007). The co-morbidity of eating disorders and anxiety disorders: A review. In *European Eating Disorders Review*. <https://doi.org/10.1002/erv.784>
- Trompeter, N., Bussey, K., Hay, P., Mond, J., Murray, S. B., Lonergan, A., Griffiths, S., Pike, K. M., & Mitchison, D. (2018). Fear of Negative Evaluation and Weight/Shape Concerns among Adolescents: The Moderating Effects of Gender and Weight Status. *Journal of Youth and Adolescence*, 47(7), 1398–1408. <https://doi.org/10.1007/s10964-018-0872-z>
- Utschig, A. C., Presnell, K., Madeley, M. C., & Smits, J. A. J. (2010). An investigation of the relationship between fear of negative evaluation and bulimic psychopathology. *Eating Behaviors*, 11(4), 231–238. <https://doi.org/10.1016/j.eatbeh.2010.05.003>
- Vandenberg, R. J., & Lance, C. E. (2000). A Review and Synthesis of the Measurement Invariance Literature: Suggestions, Practices, and Recommendations for Organizational Research. *Organizational Research Methods*, 3(1), 4–69. <https://doi.org/10.1177/109442810031002>
- Westenberg, P. M., Gullone, E., Bokhorst, C. L., Heyne, D. A., & King, N. J. (2007). Social evaluation fear in childhood and adolescence: Normative developmental course and continuity of

individual differences. *British Journal of Developmental Psychology*, 25(3), 471–483.
<https://doi.org/10.1348/026151006X173099>

Yager, Z., Diedrichs, P. C., Ricciardelli, L. A., & Halliwell, E. (2013). What works in secondary schools? A systematic review of classroom-based body image programs. In *Body Image* (Vol. 10, Issue 3, pp. 271–281). <https://doi.org/10.1016/j.bodyim.2013.04.001>

Zuair, A. A., & Sopory, P. (2022). Effects of Media Health Literacy School-Based Interventions on Adolescents' Body Image Concerns, Eating Concerns, and Thin-Internalization Attitudes: A Systematic Review and Meta-Analysis. *Health Communication*, 37(1), 20–28.
<https://doi.org/10.1080/10410236.2020.1813954>