

IAC-20,A2,4,12,x60120

## GROUND-BASED EXPERIMENTAL FACILITY FOR ORBITAL AERODYNAMICS RESEARCH: DESIGN, CONSTRUCTION AND CHARACTERISATION

Vitor T.A. Oiko<sup>a\*</sup>, Peter C.E. Roberts<sup>a</sup>, Alejandro Macario-Rojas<sup>a</sup>, Steve Edmondson<sup>a</sup>, Sarah J. Haigh<sup>a</sup>, Brandon E.A. Holmes<sup>a</sup>, Sabrina Livadiotti<sup>a</sup>, Nicholas H. Crisp<sup>a</sup>, Katharine L. Smith<sup>a</sup>, Luciana A. Sinpetru<sup>a</sup>, Jonathan Becedas<sup>b</sup>, Rosa María Domínguez<sup>b</sup>, Valeria Sullioti-Linner<sup>b</sup>, Simon Christensen<sup>c</sup>, Thomas Kauffman Jensen<sup>c</sup>, Jens Nielsen<sup>c</sup>, Morten Bisgaard<sup>c</sup>, Yung-An Chan<sup>d</sup>, Georg H. Herdrich<sup>d</sup>, Francesco Romano<sup>d</sup>, Stefanos Fasoulas<sup>d</sup>, Constantin Traub<sup>d</sup>, Daniel Garcia-Almiñana<sup>e</sup>, Marina Garcia-Berenguer<sup>e</sup>, Silvia Rodriguez-Donaire<sup>e</sup>, Miquel Sureda<sup>e</sup>, Dhiren Kataria<sup>f</sup>, Badia Belkouchi<sup>g</sup>, Alexis Conte<sup>g</sup>, Simon Seminari<sup>g</sup>, Rachel Villain<sup>g</sup>

<sup>a</sup> The University of Manchester, *Oxford Road, Manchester, M13 9PL, United Kingdom*

<sup>b</sup> Elecnor Deimos Satellite Systems, *Calle Francia 9, 13500 Puertollano, Spain*

<sup>c</sup> GomSpace A/S, *Langagervej 6, 9220 Aalborg East, Denmark*

<sup>d</sup> University of Stuttgart, *Pfaffenwaldring 29, 70569 Stuttgart, Germany*

<sup>e</sup> UPC-BarcelonaTECH, *Carrer de Colom 11, 08222 Terrassa, Barcelona, Spain*

<sup>f</sup> Mullard Space Science Laboratory (UCL), *Holmbury St. Mary, Dorking, RH5 6NT, United Kingdom*

<sup>g</sup> Euroconsult, *86 Boulevard de Sébastopol, 75003 Paris, France*

\* Corresponding Author: [vitor.oiko@manchester.ac.uk](mailto:vitor.oiko@manchester.ac.uk)

### Abstract

In very low Earth orbits (VLEO), below 450 km altitude, the aerodynamic properties of satellites are primarily determined by the flow regime, free molecular flow, and the interaction of atomic oxygen with the surfaces of the spacecraft. The Rarefied Orbital Aerodynamics Research (ROAR) facility is a novel experimental facility designed to simulate these conditions in a controlled environment to characterise the aerodynamic properties of materials. It is built as part of DISCOVERER, a Horizon 2020 project developing the different technologies required to enable the sustainable operation of satellites in VLEO. Because ROAR isn't intended to perform erosion studies, it differs quite significantly from other atomic oxygen exposure experiments and its characteristics are discussed in this work. ROAR consists of an ultrahigh vacuum system, responsible for generating the free molecular flow conditions, a source of hyperthermal oxygen atoms at orbital velocities, and mass spectrometers; the latter used to characterise the gas-surface interactions, and therefore the material's aerodynamic performance. This paper includes a description of ROAR's main components, together with the experimental methodology for materials testing and early results. Among the main parameters to be considered are atomic oxygen flux, beam shape and energy spread, mass resolution, and signal-to-noise ratio.

**Keywords:** Atomic oxygen, very low Earth Orbit, gas-surface interactions, free molecular flow, vacuum, mass spectrometry.

### Acronyms/Abbreviations

VLEO Very low Earth orbit

AO Atomic oxygen

ROAR Rarefied orbital aerodynamics research facility

INMS Ion-neutral mass spectrometer

### 1. Introduction

Operating satellites at very low Earth orbit (VLEO), comprising of altitudes below 450 km, offers a series of benefits while posing a set of interesting challenges as well. Amongst the benefits one could mention reduced costs for space system's developments, launch and operation, increased resolution data of imagery and spectroscopy that could impact directly on areas like maritime surveillance, land management, agriculture and food security, disaster monitoring, etc [1].

As for the challenges, the main difficulty of operating at a lower power of the atmosphere comes from its denser and rather aggressive composition. The main characteristics of the atmosphere at such lower altitudes, are the higher number density, with atomic oxygen, O<sup>3</sup>P, as the most abundant species. Given that atomic oxygen (AO) is very reactive, it readily adsorbs onto surfaces where it can go through a series of physical-chemical processes that usually leads to the surface's erosion [2-5]. These interactions contribute for an increase in drag that in turns is translated into a significant reduction of lifetime.

A better understanding of the mechanisms through which AO interacts with surfaces could lead to materials that are more suited to the VLEO environment and to a more tailored use during the design stages of missions and spacecraft. Currently, in order to study how materials

behave in the VLEO atmosphere, there are two common ways, ground-based experiments [6,9] or via in-orbit tests [10,11]. Whilst the latter is becoming more accessible specially through the Materials International Space Station Experiment (MISSE) [12], ground-based atomic oxygen exposure facilities are still fundamental tools for the study of materials.

The vast majority of the exposure facilities operational today are focused on investigating erosion induced by atomic oxygen. Erosion of surfaces by AO is a major concern, it can affect different spacecraft systems like optics and electronics, with the potential of compromising entire missions [13,14]. Finding materials that are resistant to atomic oxygen erosion has therefore been one of the main goals of these ground-based facilities [15,16]. In order to expedite the effects observed during the exposure experiments, many facilities have increased the AO flux to levels a few orders of magnitude above those normally found in VLEO [17]. Although it unquestionably serves the purpose of accelerating the damage caused by the atomic oxygen, thus allowing for simulations of long orbit exposures, one intrinsic issue with this approach is that it can become unrepresentative of the actual interactions that take place while in orbit.

The problem of how atoms or gases interacts with surfaces is a complex one that involves a great number of variables and uncertainties, such as composition of both the gas and the surface, energy of the gas, flux intensity, flow regime, and presence of defects on the surface [18-20]. To properly characterise the dynamics, reactions and processes involved, a facility that provides similar values of AO flux and energy distribution to those in VLEO and equipped with the appropriate detectors is required. Because of this, the DISCOVERER project [21,22] has proposed the construction of a novel experiment that is designed to investigate the gas-surface interactions between materials samples and a beam of AO. This paper provides a brief description of the facility with an update on its current stage.

## 2. Rarefied Orbital Aerodynamics Research (ROAR) facility

The Rarefied Orbital Aerodynamics Research (ROAR) facility is the name for the experiment being constructed under the DISCOVERER project. It is composed of three main systems, a vacuum system, an AO source and the detection system. The vacuum system is responsible for reaching and maintaining a free molecular flow environment during the experiments, so that the average distance travelled by a particle between two consecutive collisions is far greater than the system's characteristic length.

The AO source is responsible for producing a beam of neutral oxygen atoms with an energy distribution around 4.5 eV and flux between  $10^{13}$  and  $10^{15}$

atoms/cm<sup>2</sup>s. Detection is accomplished via mass spectrometers that are used to characterise the incoming and the scattered beams by measuring their energies and their compositions. In the next sections an overview of each system is provided, whereas a more detailed description can be found elsewhere [22].

### 2.1 Vacuum system

ROAR's vacuum system is designed to provide a mean free path of at least 100 m, which is four orders of magnitude larger than the materials samples being investigated. This requires a considerably high pumping capacity, in the order of 10 m<sup>3</sup>/s. The high volumes and the expected concentration of oxygen and other reactive species inside the chamber has led to the choice of cryo (Sumitomo CP-20 - 20m<sup>3</sup>/s) and non-evaporable getter (SAES CapaciTorr D3500 - 3.5m<sup>3</sup>/s) pumps for the vacuum system of the main chamber [23]. The experiment also counts with a turbo-molecular (Leybold TurboVac 450i - 0.45 m<sup>3</sup>/s) and a set of multistage Roots (Leybold Ecodry 65Plus - 55m<sup>3</sup>/h) pumps, the latter being used for primary pumping and regeneration of the cryopumps. Once fully commissioned, operation pressures are expected to be between  $10^{-8}$ - $10^{-9}$  mbar.

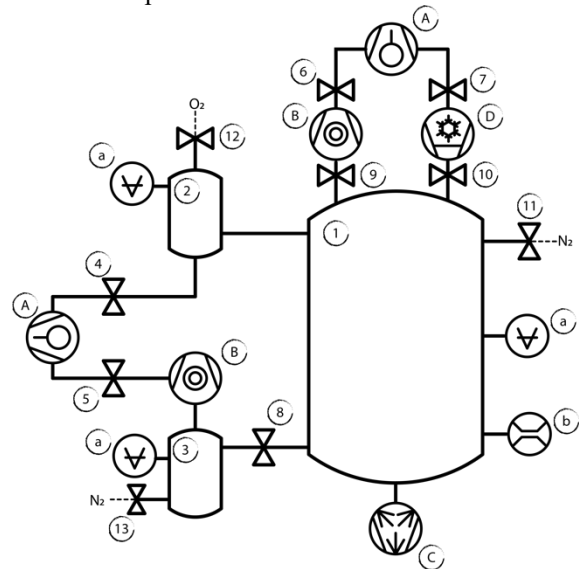

**Fig. 1: ROAR's vacuum system. Vacuum chambers are indicated by numbers, main chamber (1), AO source's chamber (2), and load lock chamber (3). Vacuum pump: multi-stage Roots (A), turbo-molecular (B), non-evaporable getter (C), and cryo (D). Valves: in-line valves (4-7), ultrahigh vacuum gate valves (8-10), high precision leak valves (11-13). Gauges and sensors: full range pressure gauge (a) and residual gas analyser (b).**

Due to the experiment's low operational pressures and the time-consuming process required to achieve these values, ROAR is designed with a second chamber that serves as load lock for sample exchange. This chamber is equipped with a turbo-molecular pump (Leybold – TurboVac 90i - 0.09 m<sup>3</sup>/s) with base pressures

around  $10^{-8}$  mbar. A residual gas analyser (Pfeiffer PrismaPro QMG250) monitors the quality of the vacuum inside the main chamber. Full schematics of ROAR's vacuum system is provided in Fig. 1.

## 2.2 Atomic oxygen source

ROAR's atomic oxygen source differs from the laser detonation sources commonly applied in other AO exposure facilities [24]. Its operation mechanism is based on a process of electron stimulated desorption and it is illustrated in Fig. 2. In summary, a silver membrane is used as the interface between the oxygen supply and the main chamber's vacuum. The oxygen molecules adsorb on to the silver membrane, dissociate into atoms that permeate through the membrane, eventually reaching the vacuum side. On the vacuum side the silver membrane is bombarded with electrons that will promote the desorption of the oxygen atoms, thus creating a beam [25].

Optimum operation is achieved when permeation and desorption balance each other and in order to maximise flux is it imperative that both processes are optimised. If the increase in permeation is not followed also by an increase in desorption, recombination of the oxygen atoms will occur at the vacuum side, generating  $O_2$  instead of  $O^3P$ . This source is estimated to produce a flux of neutral oxygen atoms between  $10^{13}$ - $10^{15}$  atoms/cm<sup>2</sup>s, with an energy distribution around 4.5 eV [25]. Fig. 2 also shows a picture of the atomic oxygen source prior its installation in ROAR where the silver membrane is visible.

To promote the desorption, ROAR is equipped with an independent electron gun capable of generating between 5 and 50 mA and with an energy range between 100 eV and 10keV (Kimball Physics – EGG3103).

## 2.3 Detection system and sample holder

The detection system of ROAR is comprised of an ion-neutral mass spectrometer (INMS) that is responsible for characterising the incoming AO beam by measuring its energy distribution and composition and the particles scattered by the sample [22]. The INMS is composed of four stages, an ion filter used to separate charged particles from the neutral ones, followed by an ioniser, a time-of-flight and an analyser. It can measure the energy and the composition (mass) of the particles before and after interacting with the materials samples, thus providing us with a clearer picture of the processes involved. By measuring the energies and masses of the particles before and after scattering with the sample, we will be able to check for different levels of AO accommodation on the surfaces, types of reaction, etc.

Another unique feature of ROAR is the fact that the INMS is mounted on a moving stage that when operated in conjunction with the sample holder it allows for measurements of scattering patterns both in and out of

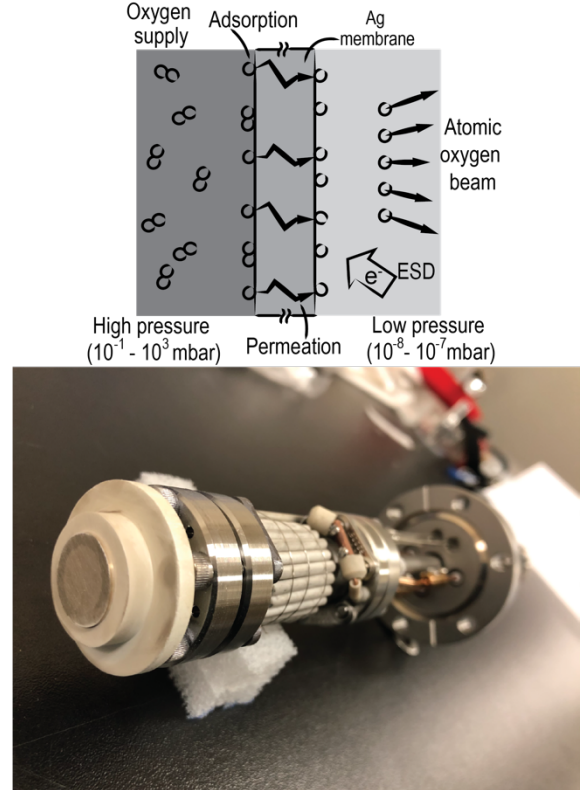

**Fig. 2: Operation mechanism of ROAR's atomic oxygen source (top). Picture of the AO source before mounting it into the main chamber (bottom).**

plane, offering almost full coverage of the hemisphere above the sample as indicated.

The sample holder designed for ROAR uses typical flag style sample supports (Omicron) and is equipped with two stepper motors (Arun Microelectronics – D35.1 and D42.1), one that alters the orientation of the sample with regards to the incoming beam by steps of 1.8 degree, and the other that provide the variation of polar angle,  $\theta$ , for the scattering maps. The moving stage where the INMS is mounted provides the azimuthal angle,  $\phi$ , which covers the second angular variation required. Maximum angular resolution are 2 degrees and 1 degree for  $\theta$  and  $\phi$ , respectively.

## 3. System's current status

ROAR is currently under the commissioning phase, with both chambers assembled, and vacuum system almost completely in place. Fig. 3 shows a schematic of the facility with pictures of its current stage. The high vacuum system, comprised of the turbo-molecular pumps with the multi-stage Roots are operational with base pressures of  $1 \times 10^{-7}$  mbar and  $9 \times 10^{-8}$  mbar achieved at the main and load lock chambers, respectively.

Preparations for the commissioning of the ultrahigh vacuum systems included commissioning of a water chiller (Lauda UCS-0800SP), for the cooling of

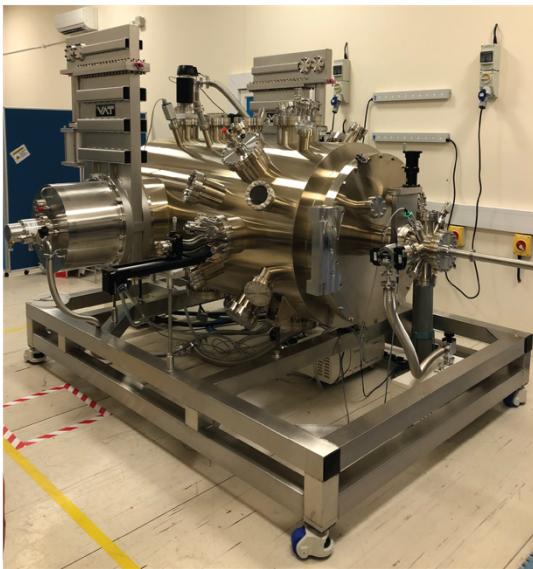
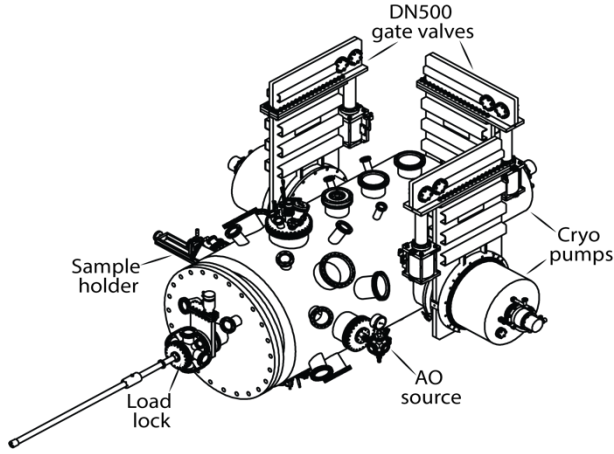

**Fig. 3:** Schematics of ROAR (top) with a picture showing the facility's current configuration.

cryopump's compressors and installation of gas lines for operation of the DN500 gate valves isolating the cryopumps from the main chamber. These activities were just recently finished, therefore no results on the commissioning of the cryo and non-evaporable getter pumps is provided.

Once the vacuum system is fully operational, efforts will be focused on the commissioning of both the atomic oxygen source and the mass spectrometers. For the AO source commissioning, characterisation and test experiments are going to be performed, which include evaluation of the effects of the electron gun on the AO production and its interference with other systems, like the sample holder and INMS. The mass spectrometers are going to be calibrated against the chamber's background acquired with the residual gas-analyser. Figure 4 shows a complete path to ROAR's full commissioning with green blocks indicating completed tasks.

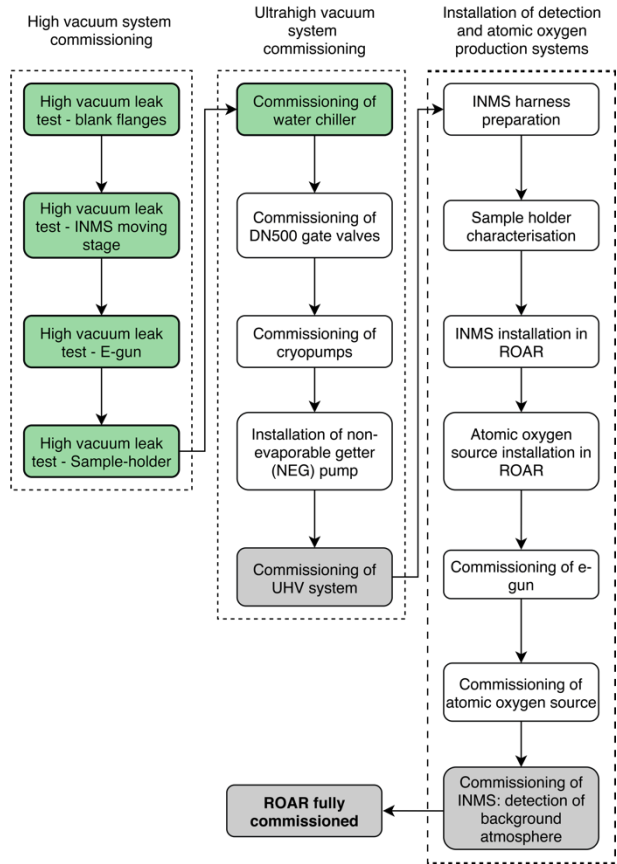

**Fig. 4:** Flowchart indicating steps to ROAR's full commissioning. Green blocks correspond to tasks already concluded.

Due to the covid-19 pandemic and the subsequent lockdowns, experimental works were halted for several months this year, deeply impacting the development of the facility. However, ROAR is expected to be operational by the December 2020.

## 6. Conclusions

This article presented a brief update on the developments of the Rarefied Orbital Aerodynamics Research (ROAR) facility, currently in commissioning stage at The University of Manchester. ROAR is an AO exposure facility designed to investigate the gas-surface interactions between a hypersonic beam of neutral oxygen atoms and a materials sample.

A general description of ROAR's vacuum system was provided, including a diagram. The atomic oxygen source and detection systems were also considered and briefly described. The experiment is currently being commissioned and is expected to be operational by December 2020.

## Acknowledgements

This project has received funding from the European Union's Horizon 2020 research and innovation

programme under grant agreement No 737183. This publication reflects only the author's view. The Agency is not responsible for any use that may be made of the information it contains.

## References

[1] N.H. Crisp, P.C.E. Roberts, S. Livadiotti, V.T.A. Oiko, S. Edmondson, S.J. Haigh, C. Huyton, L.A. Sinpetru, K.L. Smith, S.D. Worrall, J. Becedas, R.M. Domínguez, D. González, V. Hanessian, A. Mølgaard, J. Nielsen, M. Bisgaard, Y.-A. Chan, S. Fasoulas, G.H. Herdrich, F. Romano, C. Traub, D. García-Almiñana, S. Rodríguez-Donaire, M. Sureda, D. Kataria, R. Outlaw, B. Belkouchi, A. Conte, J.S. Perez, R. Villain, B. Heißerer, A. Schwalber, The benefits of very low earth orbit for earth observation missions, *Prog. Aerosp. Sci.* 117 (2020).

[2] B. A. Banks, S. K. R. Miller, and K. K. De Groh, "Atomic Oxygen Effects on Spacecraft Materials," no. NASA/TM--2003-212484, 2003.

[3] B. A. Banks, K. K. de Groh, and S. K. Miller, "Low Earth Orbital Atomic Oxygen Interactions With Spacecraft Materials," 2004.

[4] K. Moe, M. M. Moe, and S. D. Wallace, "Improved Satellite Drag Coefficient Calculations from Orbital Measurements of Energy Accommodation," *J. Spacecr. Rockets*, vol. 35, no. 3, pp. 266–272, 1998.

[5] V. N. Chernik, L. S. Novikov, T. N. Smirnova, and J. I. Kleiman, "Ground-based Atomic Oxygen Tests of Pristine and Protected polymeric Threads," *AIP Conf. Proc.*, vol. 107, pp. 107–116, 2009.

[6] J. Zhang, D. J. Garton, and T. K. Minton, "Reactive and inelastic scattering dynamics of hyperthermal oxygen atoms on a saturated hydrocarbon surface," *J. Chem. Phys.*, vol. 117, no. 13, 6239-6251, 2002.

[7] G. T. Roberts, A. R. Chambers, C. B. White, and J. I. Kleiman, "LEO Atomic Oxygen Measurements: Experiment Design and Preliminary Results," *AIP Conf. Proc.*, vol. 419, pp. 419–425, 2009.

[8] A. H. Stambler, K. E. Inoshita, L. M. Roberts, C. E. Barbagallo, K. K. de Groh, and B. A. Banks, "Ground Laboratory to In Space Atomic Oxygen Correlation for the PEACE Polymers," *AIP Conf. Proc.*, vol. 1087, no. 1, pp. 51–66, 2009.

[9] Tagawa, M. and Matsumoto, K. and Doi, H. and Yokota, K. and Ohmae, N., "Atomic Oxygen Concentration Using Reflecting Mirrors", Protection of materials and structures from the space environment, *Space Technology Proceedings*, pp. 417-429, 2006.

[10] A. F. Whitaker, J. Gregory, "LDEF Materials Results for Spacecraft Applications", NASA Conference Publication 3257, 1992.

[11] B. A. Banks, K. K. de Groh, S. K. Miller, and D. L. Waters, "Lessons Learned from Atomic Oxygen Interaction with Spacecraft Materials in Low Earth

Orbit," *AIP Conf. Proc.*, vol. 1087, no. 1, pp. 312–325, 2009.

[12] B. A. Banks, K. K. De Groh, and S. K. Miller, "MISSE Scattered Atomic Oxygen Characterization Experiment," *Program*, no. May, 2006

[13] Yokota, K.; Tagawa, M., and Ohmae, N., "Temperature Dependence in Erosion Rates of Polyimide Under Hyperthermal Atomic Oxygen Exposures", *Journal of Spacecraft and Rockets*, 40, 143-144, (2003).

[14] Buczala, D. M.; Brunsvold, A. L. & Minton, T. K., "Erosion of Kapton H® by Hyperthermal Atomic Oxygen", *Journal of Spacecraft and Rockets*, 43, 421-425, (2006).

[15] Packirisamy, S., Schwam, D., Litt, M.H., "Atomic oxygen resistant coatings for low earth orbit space structures", *Journal of Materials Science*, 30, 308–320 (1995).

[16] M.; Srinivasamurthy, N. and Agrawal, B., "Atomic oxygen protective coatings for Kapton film: a review", *Surface and Coatings Technology*, 58, pp. 1 – 17, (1993).

[17] Shpilman, Z.; Gouzman, I.; Lempert, G.; Grossman, E. & Hoffman, A., "rf plasma system as an atomic oxygen exposure facility", *Review of Scientific Instruments*, 79, 025106, (2008).

[18] Goodman, F. O., "Scattering of atoms and molecules by solid surfaces", *Critical Reviews in Solid State and Materials Sciences*, Taylor & Francis, 7, 33-80, (1977).

[19] Goodman F. O., "Three-dimensional hard spheres theory of scattering of gas atoms from a solid surface I. Limit of large incident speed," *Surf. Sci.*, vol. 7, pp. 391–421, 1967.

[20] Somorjai, G. A. and Brumbach, S. B., "The interaction of molecular beams with solid surfaces", *C R C Critical Reviews in Solid State Sciences*, Taylor & Francis, 4, 429-454, (1973).

[21] P.C.E. Roberts, N.H. Crisp, S. Edmondson, S.J. Haigh, R.E. Lyons, V.T.A. Oiko, A. Macario-Rojas, K.L. Smith, J. Becedas, G. González, I. Vázquez, Á. Braña, K. Antonini, K. Bay, L. Ghizoni, V. Jungnell, J. Morsbøl, T. Binder, A. Boxberger, G. Herdrich, F. Romano, S. Fasoulas, D. Garcia-Almiñana, S. Rodriguez-Donaire, D. Kataria, M. Davidson, R. Outlaw, B. Belkouchi, A. Conte, J.S. Perez, R. Villain, B. Heißerer, A. Schwalber, DISCOVERER – Radical Redesign of Earth Observation Satellites for Sustained Operation at Significantly Lower Altitudes, in: 68th Int. Astronaut. Congr., International Astronautical Federation (IAF), Adelaide, Australia, 2017.

[22] V.T.A. Oiko, P.C.E. Roberts, S.D. Worrall, S. Edmondson, S.J. Haigh, N.H. Crisp, S. Livadiotti, C. Huyton, R.E. Lyons, K.L. Smith, L.A. Sinpetru, B.E. Holmes, J. Becedas, R.M. Domínguez, D. González, V. Cañas, V. Hanessian, A. Mølgaard, J. Nielsen, M. Bisgaard, A. Boxberger, Y.-A. Chan, G.H. Herdrich, F.

Romano, S. Fasoulas, C. Traub, D. Garcia-Almiñana, S. Rodriguez-Donaire, M. Sureda, D. Kataria, R. Outlaw, B. Belkouchi, A. Conte, J.S. Perez, R. Villain, B. Heißerer, A. Schwalber, A Ground-Based Experimental Facility for Orbital Aerodynamics Research, in: 70th Int. Astronaut. Congr., International Astronautical Federation (IAF), Washington, DC, 2019: pp. 1–7.

[23] R. Haefer, “Vacuum and cryotechniques in space research,” *Vacuum*, vol. 22, no. 8, pp. 303–314, 1972.

[24] J. Kleiman, Z. Iskanderova, Y. Gudimenko, and S. Horodetsky, “Atomic oxygen beam sources: A critical overview,” Eur. Sp. Agency, (Special Publ. ESA SP, vol. 2003, no. 540, pp. 313–324, 2003.

[25] R. A. Outlaw, “Small ultrahigh vacuum compatible hyperthermal oxygen atom generator,” *J. Vac. Sci. Technol. A Vacuum, Surfaces, Film.*, vol. 12, no. 3, p. 854, 1994.