

Optimisation Of The Simulation Of Advanced Control Strategies For Adaptive Building Skins

Esther Borkowski¹, Mattia Donato², Giovanni Zemella², Dimitrios Rovas¹, Rokia Raslan¹

¹Institute for Environmental Design and Engineering, University College London, Central House, 14 Upper Woburn Place, London WC1H 0NN, UK

²Ove Arup & Partners, 13 Fitzroy Street, London W1T 4BQ, UK

Abstract

Adaptive building skins dynamically adapt to environmental changes, often supported by a control system. Whereas building performance simulation (BPS) tools can be employed to predict the performance of adaptive building skins, the associated control strategies within currently available BPS tools are approximated, which limits tool capability regarding properly capturing the influence of the control strategy on adaptive building skins. This study aims to assess this through the use of a co-simulation modelling framework demonstrated through a case study with automated motorised blinds with two distinct control strategies. Simulation results suggest that the cooling rate was 12.1 % higher when the blind position depended only on solar gains, but not on solar gains and sun tracking. The results of this study imply that the modelling framework predicted the performance of the case study more accurately than what would be expected for currently available BPS tools, which can increase the credibility of building performance simulations.

Introduction

Adaptive building skins are façades that dynamically adapt to changes in the interior and exterior environment to improve the overall building performance. The dynamic behaviour of these building skins is achieved either by dynamics of the building skin itself, such as the use of phase change materials (PCMs), or by mechanical actuation supported by a control system, often with an advanced control logic (Loonen et al. 2016). Considering past, current and possibly forecasted conditions, such a controller can take decisions to adjust building skin characteristics so that good performance can be achieved as measured by relevant performance indicators.

Building performance simulation (BPS) tools can be used to analyse and evaluate different design alternatives; a key aspect to this is the ability to simultaneously simulate the building skin along with the advanced control strategy to enable an integrated analysis of interacting systems (Mazzarella and Pasini 2009). Whereas currently available BPS tools, such as EnergyPlus (National Renewable Energy Laboratory (NREL) 2017), can be employed to predict the performance of adaptive building skins, they are limited in the types and ranges of control

strategies that can be modelled (Widl et al. 2014). This limitation narrows tool capability regarding properly capturing the influence of the control strategy on the dynamic behaviour of adaptive building skins. To address these limitations, co-simulation that exchanges information at each time step between different simulators may be implemented with a BPS tool used to simulate the thermal dynamics and another environment to host and represent the control logic (Wen, DiBartolomeo and Rubinstein 2011).

This study aims to assess this approach through the use of a modelling framework that tests the applicability of co-simulation. Specifically, a modelling framework that used the Functional Mock-up Interface (FMI) standard (MODELISAR 2010) was developed. This workflow employed a Functional Mock-up Unit (FMU) to exchange information by integrating EnergyPlus for the building performance simulation with the Modelica environment Dymola (Dassault Systèmes 1992, Dynasim AB 1997) for the control simulation. Modelica offers more modular and flexible modelling and simulation methods for building and control systems than what is utilised in currently available BPS tools. The framework was evaluated in a case study of a closed cavity façade (CCF) with automated motorised blinds for an office development in London with two distinct control strategies.

Background: co-simulation

Recent research has highlighted that co-simulation environments have been developed and investigated in the building sector to address the limitations associated with the ability of currently available BPS tools to simulate systems with fast dynamics properly and to represent controls appropriately (Widl et al. 2014). Co-simulation, which is premised on the exchange of data between different simulation tools at each time step, was introduced to improve the exchange and interoperation of different simulators (Broman et al. 2013). A typical application of co-simulation within the built environment is the performance assessment of building energy systems through the extension of the capabilities of currently available, domain-specific BPS tools, such as EnergyPlus, and the run-time coupling with other simulation tools, such as Modelica. For example, Favoino et al. (2016) studied the performance of switchable glazing with different control strategies using co-simulation and found

that predictive control strategies can lead to energy savings compared to rule-based control strategies.

However, Favoino et al. (2016) also identified a disadvantage of co-simulation in their study, which is the long computational time. The computational time of co-simulation was studied, for example, by Sagerschnig et al. (2011), who used the Building Controls Virtual Test Bed (BCVTB) (Wetter 2016), a modular open-source middleware for co-simulation, to couple EnergyPlus with Matlab, a numerical computing environment, to investigate controllers for radiant ceilings. The findings of the study show that, depending on the model size, the computational time with co-simulation was approx. 2.5 times higher than that with the stand-alone simulation due to the synchronisation between models. The long computational time of the co-simulation undertaken by Sagerschnig et al. (2011) may be due to the Ptolemy environment that BCVTB builds upon and that introduces an additional socket-based transaction layer into the communication between the different simulators, which increases the overheads due to co-simulation (Nouidui and Wetter 2014).

To standardise information exchange between heterogeneous tools in co-simulation contexts, the FMI standard was developed. First released in 2010 by the ITEA2 MODELISAR project, it facilitates the development and the interoperability of tools using a combination of XML-file, C-code and shared libraries (Nouidui and Wetter 2014). A model conforming to a specific interface, in line with the FMI standard, can be encapsulated and shared as an FMU, which can be flexibly and transparently integrated with other standard-compliant FMUs generated by heterogeneous tools (Broman et al. 2013).

The FMI standard is supported by various tools, including EnergyPlus, which offers an FMU export interface for co-simulation. The software package EnergyPlusToFMU (Nouidui, Lorenzetti and Wetter 2013) enables the export of EnergyPlus as an FMU for co-simulation, which can be imported in another simulation environment, such as Dymola, where the FMU exported from EnergyPlus appears as input/output block that can be connected with other models.

The EnergyPlusToFMU environment has been used in various research studies. By way of example, Li et al. (2017) studied the impact of occupant behaviour on the performance of a single-occupancy office and found that co-simulation was useful to model a control strategy based on the stochastic nature of occupant behaviour, which reduced the energy consumption compared to a control based on predefined occupant schedules.

Similar to Li et al. (2017), this study uses the software package EnergyPlusToFMU, but it tests the applicability of co-simulation using a case study of an office development in London, whose results can be used to inform the design process by providing more accurate and representative predictions of the building performance.

Simulation

To investigate the application of the modelling framework, the research design used in this study adopted a case study approach due to the exploratory nature of the research (Yin 2014). To analyse the data predicted by the modelling framework, a statistical analysis was used, which focused only on occupied hours (07:00 to 19:00).

Room model in EnergyPlus

The case study was an 18 m² bay of a typical floor of a 50-storey office development in Central London. The air change rate was constantly 0.3 h⁻¹, and setpoint temperatures for the thermostat were 21 °C in winter and 24 °C in summer. The South-oriented façade of the case study was a CCF, as illustrated in Figure 1. A CCF is a unitised system presenting a sealed cavity between the inner thermal line composed of a double-glazed unit and the outer skin. Key advantages of CCFs are:

- solar control system protected from weathering and wind;
- good solar performance as the shading is on the outside of the thermal line;
- low U-value due to the sealed cavity between the two skins.

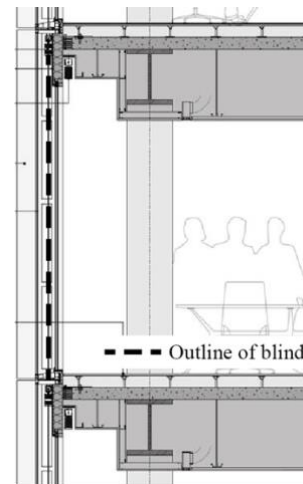

Figure 1: Vertical section of CCF

The properties of the CCF used in this study are shown in Table 1.

Table 1: Façade properties

Property	Value
Centre-pane U-value	0.90 W/m ² K
g-value	Blinds off: 0.52 Blinds on: 0.12
Visible light transmittance	Blinds off: 65 % Blinds on: 5 %

The façade had automated motorised blinds with six different blind positions, as shown in Table 2. The properties of the blinds are summarised in Table 3.

Table 2: Blind positions

Open	Horizontal	Tilt 30°	Tilt 45°	Tilt 60°	Closed

Table 3: Blind properties

Property	Value
Dimensions	Slat width: 80 mm Slat distance: 72 mm
Colour	Light grey
Reflectance	Solar: 65 % Visible: 71 %

Controller model in Dymola

The blinds controlled solar heat gains and glare entering the building through the façade by a building management system (BMS):

- **Solar gains.** Blind positions (i.e. slat angles) were based on the intensity of the incident solar radiation ($SolRad$).
- **Glare.** To prevent direct sunlight passing through the façade, blind positions were defined based on the sun track, i.e. site solar altitude ($SolAlt$), and the slats of the cut-off angle.

Control thresholds for $SolRad$ and $SolAlt$ are apparent from Table 4.

Table 4: Control thresholds for each blind position

Blind position	Incident solar radiation [W/m^2]	Site solar altitude [degrees]
Open	$SolRad < 240$	-
Horizontal	$240 \leq SolRad < 330$	$SolAlt > 42.0$
Tilt 30°	$330 \leq SolRad < 530$	$42.0 \geq SolAlt > 24.8$
Tilt 45°	$530 \leq SolRad < 770$	$24.8 \geq SolAlt > 15.3$
Tilt 60°	$770 \leq SolRad < 920$	$15.3 \geq SolAlt > 3.9$
Closed	$920 \leq SolRad$	$3.9 \geq SolAlt$

Two control strategies were investigated:

1. **SG.** Control based on solar gains only.
2. **SG+ST.** Control based on solar gains and sun tracking.

When the sky was cloudy with a global horizontal illuminance ($HorIll$) lower than 15,000 lux, the control strategies SG and SG+ST were always overridden, and the blinds were fully retracted.

Modelling framework

The study used EnergyPlus v8.8.0 and Dymola v2018 FD01 together with the FMI standard v1.0. The FMI standard had been favoured over BCTVB because it is a non-proprietary industry standard. It also eliminates the

additional transaction layer and decreases the complexity of the co-simulation. EnergyPlus was used as a slave simulation tool, which was packaged as an FMU for co-simulation, and Dymola as a master simulation tool, which supported the import of the FMU for co-simulation and was responsible for coordinating the overall simulation and data transfer (Bastian et al. 2011).

The first step in the study was to implement the room model in EnergyPlus. To couple EnergyPlus to another simulation tool, the External Interface of EnergyPlus, whose objects received their inputs from Dymola at each time step, had to be activated. The software package EnergyPlusToFMU v2.0.2 was used to export the case study modelled in EnergyPlus as an FMU for co-simulation using the FMI standard that was then imported into Dymola.

To actuate the blind position, a blind controller was modelled in Dymola, which can be seen in Figure 2. As shown in Figure 3, the variables $SolRad$, $SolAlt$ and $HorIll$ were transferred from EnergyPlus to Dymola at each synchronisation time step via the FMI standard. The FMU had the outputs $yBlind$ and $ySlat$, which were written to the control types Control Status and Slat Angle of the EMS module of EnergyPlus, an advanced feature of EnergyPlus for custom-modelled control strategies, at each synchronisation time step and which were used through the EMS module in EnergyPlus.

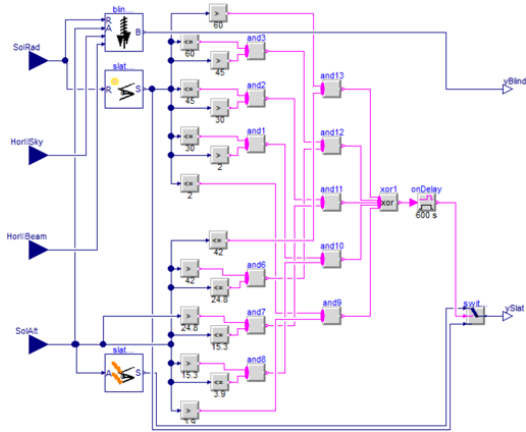

Figure 2: Controller model in Dymola

Simulations were run for an entire year with the DSY2 weather file of London Gatwick (Hacker, Belcher and White 2014) and a time step of 10 minutes. This time step was chosen to achieve better accuracy for the simulation results and was obtained from ‘simple interpolation between “last hour’s” values and “this hour’s” values’ of the hourly weather data (U.S. Department of Energy (DOE) 2017b, p. 2648). The 10-minute time step of EnergyPlus had to be equal to the sampling time of the FMU, which was achieved through a sampler that sampled the input signals and computed the output signals from the sampled input signals by a given sample period. Dymola then synchronised the FMU every simulation time step of 10 minutes.

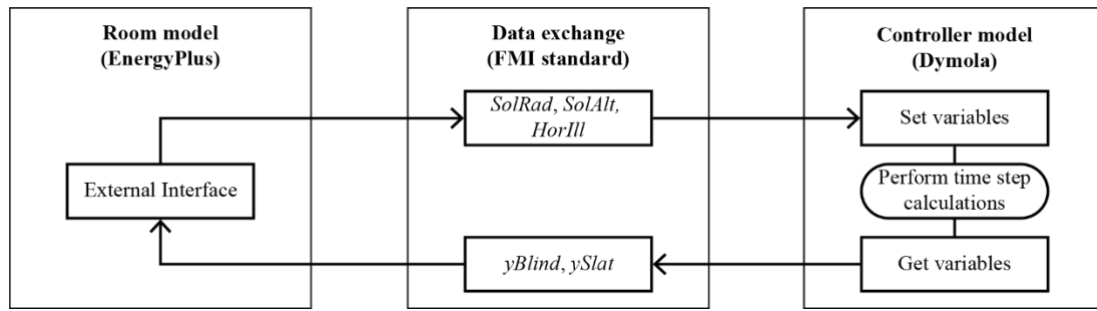

Figure 3: Data exchange between EnergyPlus and Dymola

Discussion and result analysis

Simulation results suggest that the control strategies SG and SG+ST significantly influenced the predicted performance of the case study. The mean cooling rate, which was the cooling load defined as the rate at which heat was removed from the room to maintain setpoint temperatures, of SG was 12.1 % higher than the mean cooling rate of SG+ST (SG: 495.7 kWh, SG+ST: 442.2 kWh). This suggested that on an average the monthly cooling rate of SG was higher compared to SG+ST, especially during summer, as can be seen in Figure 4.

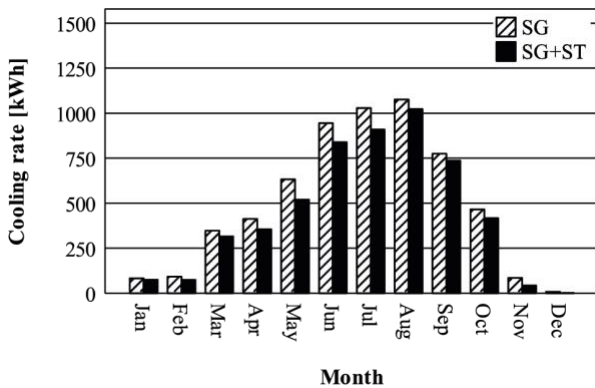

Figure 4: Monthly cooling rate during occupied hours

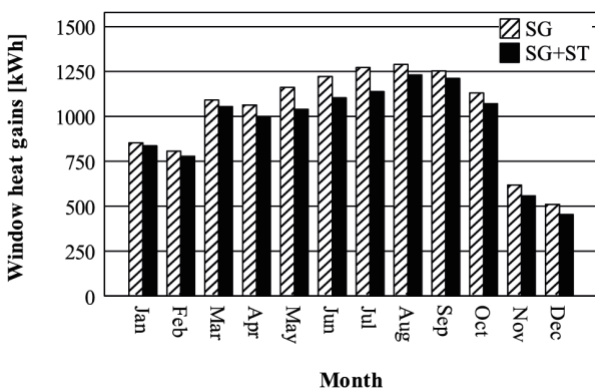

Figure 5: Monthly window heat gains during occupied hours

Similarly to the predicted cooling rate, Figure 5 shows a difference in the monthly window heat gains between SG and SG+ST. The mean window heat gains of SG were 7.0 % higher than the mean window heat gains of SG+ST (SG: 1022.8 kWh, SG+ST: 956.0 kWh), which indicated that on an average the window heat gains of SG were higher.

Since SG showed higher monthly window heat gains, the sum of the heat flow from the façade in the room was higher when the blind position was only dependent on solar gains (SG), but not on solar gains and sun tracking (SG+ST). The higher heat flow affected the higher cooling rate because the thermostat had to cool more heat to maintain setpoint temperatures. This became particularly evident from the months of January and February, in which the sky was cloudier (global horizontal illuminance < 15,000 lux) in many cases compared to the months of December and November. As a consequence, blinds were more often fully retracted in January and February than in December and November resulting in higher window heat gains and, hence, a higher cooling rate.

The higher window heat gains and the higher cooling rate of SG may be due to the percentage of time each blind position occurred throughout the year, as shown in Figure 6. SG+ST decreased the percentage of time when the blinds were open from 69.6 % (SG) to 61.1 % (SG+ST). Blind positions also occurred more often in tilted or closed positions in SG+ST than in SG. For example, blinds were in tilted 60° position 0.5 % of the time in case of SG, but 7.6 % in case of SG+ST.

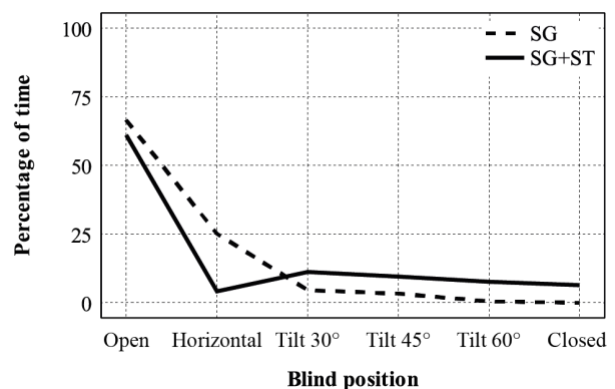

Figure 6: Blind positions during occupied hours

The consequence of the predicted performance of SG+ST that blinds were less often open and more often in tilted or closed positions compared to SG was that heat from the direct sun was blocked more minimising window heat gains and the cooling rate. The risk of glare was also potentially reduced by SG+ST, as no direct sunlight passed through the façade, which might improve visual comfort levels.

The results of this study confirm that the co-simulation modelling framework predicted the performance of the case study with fewer simplifications and approximations and, thus, more accurate and representative predictions than what would be expected from results predicted by currently available BPS tools. In those tools, the blind controller could have only been modelled in fragments. In EnergyPlus, for example, the slat angle of the blinds could have been either fixed, defined by a schedule or automatically oriented to block beam solar radiation (DOE 2017b). An alternative would have been to model the blind controller in the EMS module of EnergyPlus. However, each EMS programme line is limited to 100 characters (DOE 2017a), which would have complicated the modelling of a control strategy that requires a sequence of different logical structures, such as the blind controller in this study. A possible explanation for the results of this study might be the differing model representation and numerical methods for control strategies between the tools:

- **EnergyPlus.** The control strategies within EnergyPlus are preset and time-scheduled, which indicates that control actions are fixed and based on time rather than on boundary conditions or simulation state variables (Loonen et al. 2016). The programming language of the EMS module of EnergyPlus is simplistic compared to full-blown programming languages, such as C++, and it is limited due to the integration into the EnergyPlus tool structure (Ellis, Torcellini and Crawley 2007). As a result, tool capabilities of EnergyPlus are limited regarding properly modelling the dynamic behaviour of adaptive building skins.
- **Modelica.** Compared to EnergyPlus, Modelica is capable of modelling the dynamic behaviour of adaptive building skins due to its support of several modelling formalisms (e.g. differential-algebraic equations (DAEs)), which allows Modelica to model dynamic systems, whose states evolve in time (Fritzson 2014).

The present results are relevant in at least two major respects. First, more accurate and representative predictions of control strategies for adaptive building skins can bridge the observed performance gap between design and operational performance of buildings (Aste, Manfren and Marenzi 2017) and increase the rigour and credibility of performance simulations of buildings. Second, the use of co-simulation environments could

assist design teams in the design process in the context of adaptive building skins and offer the opportunity to verify the building performance through more accurate and representative predictions. As a consequence, the application of co-simulation environments could provide more realistic quantitative data to support sound decision-making.

Conclusion

The aim of this study was to assess co-simulation demonstrated through a case study with automated motorised blinds under two different control strategies. The results of this assessment show that the window heat gains and the cooling rate were higher when the blind position was only dependent on solar gains (SG), but not on solar gains and sun tracking (SG+ST). This result can be explained by the fact that blinds were less often open and more often in tilted or closed positions in SG+ST than in SG. An implication of this result is that co-simulation has the potential to predict the performance of control strategies for adaptive building skins with a higher accuracy and, hence, with more representative predictions than what would be expected for currently available BPS tools.

However, a limitation of this study is the size of the case study, which was an 18 m² bay of a typical floor of a 50-storey office development in London. Since the dynamic behaviour of adaptive building skins could differently affect the performance of the entire office development, further studies are needed to explore the effect of control strategies on the dynamic behaviour of adaptive building skins for entire buildings. Future work will also investigate the validity of the predicted results of the modelling framework, which will be compared with monitored data from the control of the case study building once completed.

References

- Aste, Niccolò, Massimiliano Manfren and Giorgia Marenzi 2017. 'Building Automation and Control Systems and performance optimization: A framework for analysis'. 2017. *Renewable and Sustainable Energy Reviews* 75:313–330.
- Bastian, Jens, Christoph Clauß, Susann Wolf and Peter Schneider 2011. 'Master for Co- Simulation Using FMI'. 2011. In *Proceedings 8th Modelica Conference*, 115–120. Dresden, Germany.
- Broman, David, Christopher Brooks, Lev Greenberg, Edward A. Lee, Michael Masin, Stavros Tripakis and Michael Wetter 2013. 'Determinate Composition of FMUs for Co-Simulation'. 2013. In *2013 Proceedings of the International Conference on Embedded Software, (EMSOFT 2013)*. Montreal, Canada.
- Dassault Systèmes 1992. *Dymola*. 1992. Lund, Sweden. Accessed 14th March 2018. <http://www.dymola.com>.

- DOE 2017. *EnergyPlus Version 8.8.0 Documentation - Application Guide for EMS*. 2017a.
- DOE 2017. *EnergyPlus Version 8.8.0 Documentation - Input Output Reference*. 2017b.
- Dynasim AB 1997. *Modelica - A Unified Object-Oriented Language For Physical Systems Modeling*. 1997. Lund, Sweden. Accessed 14th March 2018. <https://www.modelica.org>
- Ellis, Peter G., Paul A. Torcellini and Drury B. Crawley 2007. 'Simulation of Energy Management Systems in EnergyPlus'. 2007. In *Proceedings: Building Simulation 2007*, 1346–1353. Beijing, China.
- Favoino, Fabio, Francesco Fiorito, Alessandro Cannavale, Gianluca Ranzi and Mauro Overend 2016. 'Optimal control and performance of photovoltaic switchable glazing for building integration in temperate climates'. 2016. *Applied Energy* 178:943–961.
- Fritzon, Peter 2014. *Principles of Object Oriented Modeling and Simulation with Modelica 3.3: A Cyber-Physical Approach*. 2014. 2nd ed. 1-1256. John Wiley & Sons.
- Hacker, Jake, Stephen Belcher and Andrew White 2014. *Chartered Institution of Building Services Engineers (CIBSE) TM49: Design Summer Years for London Design Summer Years for London*. 2014. London, United Kingdom.
- Li, Rongling, Feng Wei, Yang Zhao and Wim Zeiler 2017. 'Implementing Occupant Behaviour in the Simulation of Building Energy Performance and Energy Flexibility: Development of Co-Simulation Framework and Case Study'. 2017. In *Proceedings of Building Simulation 2017*, 1339–1346. San Francisco, USA.
- Loonen, Roel C. G. M., Fabio Favoino, Jan L. M. Hensen and Mauro Overend 2016. 'Review of current status, requirements and opportunities for building performance simulation of adaptive facades'. 2016. *Journal of Building Performance Simulation* 10 (2): 1–19.
- Mazzarella, Livio, and Martina Pasini 2009. 'Building Energy Simulation and Object-Oriented Modelling: Review and Reflections Upon Achieved Results and Further Developments'. 2009. In *Proceedings of the Eleventh International International Building Performance Simulation Association (IBPSA) Conference*, 638–645. Glasgow, Scotland.
- MODELISAR 2010. *Functional Mock-up Interface (FMI) 1.0*. 2010. Accessed 14th March 2018. <http://fmi-standard.org>
- Nouidui, Thierry S., David Lorenzetti and Michael Wetter 2013. *EnergyPlusToFMU*. 2013. Berkeley, USA. Accessed 14th March 2018. <http://simulationresearch.lbl.gov/fmu/EnergyPlus/export/index.html>.
- Nouidui, Thierry S., and Michael Wetter 2014. 'Tool coupling for the design and operation of building energy and control systems based on the Functional Mock-up Interface standard'. 2014. In *Proceedings of the 10th International Modelica Conference*, 311–320. March. Lund, Sweden.
- Nouidui, Thierry S., Michael Wetter and Wangda Zuo 2013. 'Functional Mock-up Unit Import In EnergyPlus For Co-simulation'. 2013. In *Proceedings of BS2013: 13th Conference of International Building Performance Simulation Association*, 3275–3282. Chambéry, France.
- NREL 2017. *EnergyPlus 8.8.0*. 2017. Lakewood, USA. Accessed 14th March 2018. <https://energyplus.net>.
- Sagerschnig, Carina, Dimitrios Gyalistras, Axel Seerig, Samuel Prívarva, Jiří Cigler and Zdeněk Vana 2011. 'Co-simulation for building controller development: The case study of a modern office building'. 2011. In *Proceedings of CISBAT 2011*, 955–960. Lausanne, Switzerland.
- Wen, Yao-Jung, Dennis DiBartolomeo and Francis Rubinstein 2011. 'Co-simulation Based Building Controls Implementation with Networked Sensors and Actuators'. 2011. In *Proceedings of the Third ACM Workshop on Embedded Sensing Systems for Energy-Efficiency in Buildings*, 55–60. Seattle, USA.
- Wetter, Michael 2016. *Building Controls Virtual Test Bed (BCVTB)*. 2016. Berkeley, USA. Accessed 14th March 2018. <http://simulationresearch.lbl.gov/bcvtb/releases/latest/doc/manual/index.xhtml>.
- Widl, Edmund, Benoît Delinchant, Svea Kübler, Dan Li, Wolfgang Müller, Victor Norrefeldt, Thierry S. Nouidui et al. 2014. 'Novel simulation concepts for buildings and community energy systems based on the Functional Mock-up Interface specification'. 2014. In *2014 Workshop on Modeling and Simulation of Cyber-Physical Energy Systems (MSCPES)*. Berlin, Germany.
- Yin, Robert 2014. *Case Study Research: Design and Methods*. 2014. 5th ed. 1–282. Thousand Oaks, USA: SAGE.