



# Multi-parametric mixed integer linear programming under global uncertainty

Vassilis M. Charitopoulos, Lazaros G. Papageorgiou, Vivek Dua\*

Department of Chemical Engineering, Centre for Process Systems Engineering, University College London, Torrington Place, London WC1E 7JE, United Kingdom

## ARTICLE INFO

### Article history:

Received 15 September 2017

Revised 12 April 2018

Accepted 13 April 2018

Available online 18 April 2018

### Keywords:

Optimisation under uncertainty

Multi-parametric programming

Mixed integer linear programming

Cylindrical algebraic decomposition

Grobner bases

Process scheduling

## ABSTRACT

Major application areas of the process systems engineering, such as hybrid control, scheduling and synthesis can be formulated as mixed integer linear programming (MILP) problems and are naturally susceptible to uncertainty. Multi-parametric programming theory forms an active field of research and has proven to provide invaluable tools for decision making under uncertainty. While uncertainty in the right-hand side (RHS) and in the objective function's coefficients (OFC) have been thoroughly studied in the literature, the case of left-hand side (LHS) uncertainty has attracted significantly less attention mainly because of the computational implications that arise in such a problem. In the present work, we propose a novel algorithm for the analytical solution of multi-parametric MILP (mp-MILP) problems under global uncertainty, i.e. RHS, OFC and LHS. The exact explicit solutions and the corresponding regions of the parametric space are computed while a number of case studies illustrates the merits of the proposed algorithm.

© 2018 The Authors. Published by Elsevier Ltd.

This is an open access article under the CC BY license. (<http://creativecommons.org/licenses/by/4.0/>)

## 1. Introduction

Mathematical modelling is a non trivial task that requires deep and thorough understanding of the principles and phenomena involved in the problem under study. Inevitably, mathematical modelling relies on a number of assumptions and simplifications due to lack of exact knowledge about the system under examination, thus rendering any solution liable to uncertainty. The classification of uncertainty in optimisation problems is a challenging task but broadly one could classify the uncertainty as model intrinsic and extrinsic. Model intrinsic uncertainty refers to a number of parameters that the modeller does not have explicit knowledge of, e.g. kinetic constants, stoichiometric coefficients, equipment efficiency etc. For this kind of uncertainty, the value used in the models is experimentally calculated or provided by the manufacturer of the equipment; even in that case, these values cannot be known exactly and a number of assumptions is usually employed. Note that this kind of uncertainty, appears most of the times on the left-hand side (LHS) of the constraints. On the other hand, model extrinsic uncertainty refers to data that affect the model due to factors which cannot be controlled at a level of model abstraction. Examples of model extrinsic uncertainty can be regarded as, the cost

of raw material, emissions restriction policies, product demand for subsequent planning periods etc. This kind of uncertainty is more likely to appear on the right-hand side (RHS) of the constraints and in the objective function's coefficients (OFC). Consideration of uncertainty in process systems engineering is of great importance as it can endanger the optimality or even the feasibility of a solution that was computed in a deterministic way (Apap and Grossmann, 2017; Sahinidis, 2004). In an effort to avoid such occasions, a number of mathematical formulations and solution techniques have been proposed in the literature with the goal to create models which are robust towards uncertainty. Stochastic programming (Apap and Grossmann, 2017; Bertsimas and Sim, 2004; Birge and Louveaux, 2011) relies on the availability of historical data which can provide statistical information about the behaviour of uncertain parameters. In stochastic programming, the unknown parameters are assumed to follow a discrete probability distribution and the decision variables are classified into two groups: “here and now” and “wait and see”. Depending on the instances that the uncertainty is expected to be revealed, the mathematical program is referred to as “two-stage” or “multi-stage” with the objective to minimise the cost of the initial actions. Robust optimisation (RO), assumes that all constraints of the optimisation should never be violated and aims to provide a solution that is feasible regardless of the extent of the actual uncertainty. Because of that, RO is often conceived as conservative or worst-case oriented (Ben-Tal and Nemirovski, 2002).

\* Corresponding author.

E-mail address: [v.dua@ucl.ac.uk](mailto:v.dua@ucl.ac.uk) (V. Dua).

**Table 1**  
Summary of developments in multi-parametric programming theory.

Multi-parametric Linear programming (mp-LP)	Saaty and Gass (1954), Yuf and Zeleny (1976), Schechter (1987) Gal (1995), Borrelli et al. (2003), Filippi (2004), Hladik (2010), Charitopoulos et al. (2017a)
Multi-parametric (mixed integer) Quadratic programming (mp-(MI)QP)	Dua et al. (2002), Bemporad et al. (2002), Tøndel et al. (2003) Spjøtvold et al. (2006), Gupta et al. (2011), Oberdieck and Pistikopoulos (2015)
Multi-parametric mixed integer Linear programming (mp-MILP)	Geoffrion and Nauss (1977), Jenkins (1990), Acevedo and Pistikopoulos (1999) Dua and Pistikopoulos (2000), Faisca et al. (2009)
Multi-parametric (mixed integer) Nonlinear programming (mp-(MI)NLP)	Dua and Pistikopoulos (1998, 1999) Acevedo and Salgueiro (2003), Pistikopoulos et al. (2007), Fotiou et al. (2006), Charitopoulos and Dua (2016), Charitopoulos et al. (2017b)
Multi-parametric Global optimisation (mp-GO)	Fiacco (1990), Dua et al. (2004) Wittmann-Hohlbein and Pistikopoulos (2012a), Oberdieck et al. (2014)

For the study of the effect of uncertain parameters on the optimal solution, the two main methodologies reported in the open literature are: sensitivity analysis and (multi-)parametric programming. The former provides information about the effect of uncertainty around the neighbourhood of the nominal value while the latter characterises explicitly its effect on the optimal solution throughout the entire range of parametric variability. Next, we review the developments in multi-parametric programming theory in order to familiarise the reader with the topic of this article.

### 1.1. Literature review

Multi-parametric programming (mp-P) is an optimisation based technique which systematically studies the effect of uncertain parameters on the optimal solution of mathematical programming problems. Through multi-parametric programming, one aims to compute offline, the explicit optimal solution to a mathematical program which consists of two parts:

- The optimisers and the optimal objective value as functions of the uncertain parameters, i.e.  $x(\theta)$  and  $z(\theta)$ , respectively.
- The regions of the parametric space where each explicit solution remains optimal. These regions are also known and will be referred to for the rest of the article as critical regions (CRs).

The distinct feature of mp-P is the fact that, under the presence of uncertainty, the need for constant re-optimisation is replaced by efficient function evaluations that can be performed online whenever the uncertainty is realised. For this reason, mp-P has attracted the interest of many researchers and the main milestones in the history of mp-P are summarised in Table 1.

Gass and Saaty (1954, 1955a, 1955b) shortly after the invention of the simplex algorithm studied the parametric analysis of the optimal solution for Linear Programming (LP) problems when uncertain cost coefficients are considered in the objective functions. However, the first systematic framework for (multi-)parametric linear programming (mp-LPs) problems was proposed by Gal and Nedoma (1972,1975) who studied the solution of mp-LPs with perturbation on the RHS of the constraints and/or the OFC, i.e. RIM-mp-LP. For the case of mp-LPs the majority of the algorithms employ the optimal basis invariance to create the corresponding CRs and compute the explicit optimisers. On the contrary, Borrelli et al. (2003) proposed an algorithm for the solution of mp-LPs based on the direct exploration of the parametric space studying the underlying geometry of the problem. Another algorithm for mp-LP problems was proposed by Jones and Morrari (2006) who revisited the classic mp-LP as linear complementary problems and

employed lexicographic perturbation to efficiently deal with degeneracy in mp-LPs. Note that the aforementioned algorithm can handle RIM-mp-LP problems as well as multi-parametric quadratic programming (mp-QP) problems.

Multi-parametric mixed integer linear programming (mp-MILP) problems, have been studied by Acevedo and Pistikopoulos (1999), Dua and Pistikopoulos (2000), Li and Ierapetritou (2007a) to name a few. For the solution of mp-MILPs the decomposition approach of Dua and Pistikopoulos (2000) has proven to be computationally advantageous compared to the rest. It involves an iterative scheme between the solution of a master MIP problem and slave mp-LPs until the master MIP is infeasible. During this procedure, integer and parametric cuts are employed to prevent investigation of previously explored solutions.

Multi-parametric (mixed integer) quadratic programming (mp-(MI)QP) problems form another important class of mp-P problems due to their application in optimal control schemes. The first algorithm for mp-QPs was devised by Dua (2000) where the Karush–Kuhn–Tucker (KKT) conditions of optimality were solved explicitly and was later on applied in the seminal work of Bemporad et al. (2002) leading to the concept of explicit model predictive control, while in Dua et al. (2002) the mp-MIQP problems were treated.

The global optimisation of non-convex mp-NLPs and mp-MILPs with RHS uncertainty was initially discussed by Dua et al. (2004) and the authors proposed four different parametric convex overestimators along with a B&B algorithm. Note that Fiacco (1990) had proposed a solution technique for global optimisation for the case of non convex multi-parametric separable NLPs restricted to a convex set. Another algorithm for the global optimisation of mp-MILPs for RIM problems was proposed by Faisca et al. (2009). The authors follow the decomposition scheme as in Pertsinidis et al. (1998) and Dua and Pistikopoulos (2000) where the integer vector is fixed by the solution of a master MINLP to global optimality and then is fixed resulting in a slave mp-LP. Despite the merits of the aforementioned algorithm, because of the non-convex nature of the problem, the comparison procedure of overlapping CRs is not always computationally possible and thus the authors for these cases store the corresponding solutions in a parametric envelope and the best one is chosen online through function evaluation.

Wittmann-Hohlbein and Pistikopoulos (2012b) proposed a computationally efficient two stage method for the approximate solution of mp-MILPs under global uncertainty. In order to handle LHS uncertainty, the authors employ worst-case oriented RO and thus render the initial problem partially immune to uncertainty. The

partially immune problem is practically an RIM-mp-MILP problem which can be solved by existing algorithms. Note that although RO can handle efficiently LHS uncertainty, the resulting solution can be overly conservative or even unbounded for some instances. As far as the explicit solutions are considered, again no comparison procedure is followed and the determination of the best solution is done via online evaluation. Later on, the same authors (Wittmann-Hohlbein and Pistikopoulos, 2012a) studied mp-MILP problems with only LHS uncertainty. When LHS is introduced to the problem, bilinear terms arise either in the form of  $\theta \cdot x$  or  $\theta \cdot y$  rendering the problem a non-convex mp-MINLP. The proposed spatial B&B scheme from this work encompasses the construction of suitable McCormick envelopes that transform the LHS uncertainty to RHS and branching schemes on the optimisation variables and/or uncertain parameters. Computational studies showed that the algorithm can be computationally onerous as it results in a large number of CRs and also the quality of the solution is highly dependent on the branching scheme selected. Nevertheless, this work underlines the complexity of the resulting mp-P when LHS is considered. Global uncertainty in general mp-MILPs was also studied by Li and Ierapetritou (2007a) and the authors employed the optimality conditions of LPs for the definition of explicit solutions by retrieving the corresponding optimal bases. When LHS uncertainty was also considered, projection schemes were employed and approximations of the non-convex CRs were computed. Finally, a solution algorithm for the single parametric case of LHS in p-LPs was devised by Khalilpour and Karimi (2014) that included inversion techniques of perturbed matrices.

1.2. Problem statement

The aim of this article is to provide a solution algorithm for the most general case of mp-MILPs, i.e. the case where uncertain parameters appear simultaneously on the RHS, OFC and LHS (global uncertainty).

$$\text{mp - MILP}_{\text{Global}} = \begin{cases} z(\theta) = \min_{x,y} c^T(\theta)x + d^T(\theta)y \\ \text{subject to : } A(\theta)x + W(\theta)y \leq b(\theta) \\ \Delta(\theta)x + \Psi(\theta)y = \gamma(\theta) \\ x \in X \subseteq \mathbb{R}^{n_x}, y \in \{0, 1\}^{n_y} \\ \theta \in \Theta \subseteq \mathbb{R}^{k_\theta} \end{cases} \quad (1)$$

Problem (1), is a multi-parametric programming problem with non-convex parametric objective function and a non-convex feasible set. The non-convexity of the parametric objective function arises from the bilinear terms in the form of either  $c^T(\theta) \cdot x$  or  $d^T(\theta) \cdot y$ . The parametric feasible set of (1) is also non-convex because of the presence of bilinear terms between the optimisation variables, i.e.  $x$  and the uncertain entries of the technology matrix, i.e.  $A(\theta)$ . As already stated in the previous section of the article, the aforementioned problem remains as one of the biggest challenges because of its computational complexity. The challenges involved in the solution of problem (1) are:

- The computation of the explicit optimisers, i.e.  $x(\theta)$ , and the CRs where each explicit solution is optimal.
- Because of the non-convex nature of the problem it is likely that a number of CRs overlap in the same region of the parametric space. In order to provide at the end one explicit solution per CR, one needs to follow a comparison procedure which in the state of the art requires solving a number of MINLPs to global optimality.

Many problems in PSE can be formulated as MILPs and thus providing a solution technique for mp-MILPs under global uncertainty can significantly enhance the applied value of such solutions. Acevedo and Pistikopoulos (1997) studied the problem of plant synthesis under demand uncertainty while uncertainty in

Table 2  
mp-MILP algorithms.

Algorithm	Uncertainty class			Explicit solutions per CR
	RHS	OFC	LHS	
Acevedo and Pistikopoulos (1999)	✓			1
Dua and Pistikopoulos (2000)	✓			1
Li and Ierapetritou (2007a)	✓	✓	✓	1
Fáisca et al. (2009)	✓	✓		2
Wittmann-Hohlbein and Pistikopoulos (2012a)			✓	1
Oberdieck et al. (2014)	✓	✓		1.3

process planning has also been formulated as a parametric problem (Pistikopoulos and Dua, 1998). Process scheduling forms another important class of problems that has been studied through parametric programming. Ryu et al. (2007) studied the scheduling of zero-wait batch processes and they considered variable processing times after the employment of linearisation techniques. Jia and Ierapetritou (2006) proposed a framework for RHS uncertainty in scheduling problems that leads to the solution of an mp-MILP problem. Li and Ierapetritou (2007b) provided a generalised framework for process scheduling under uncertainty where depending on the topology of the uncertainty (RHS, LHS, OFC) different mixed integer mp-P problems had to be solved.

Despite the considerable attention that mp-P has drawn from the research community (Charitopoulos and Dua, 2017; Pistikopoulos et al., 2012) the solution of mp-MILPs under global uncertainty remains one of the least studied problem due to the computational complexity involved. In Table 2 an updated summary of the proposed algorithms for mp-MILPs is presented along with the classes of uncertainty that can be handled. In the third column of Table 2, the average number of explicit solution per CR is given based on computational studies reported in corresponding papers. To the best of our knowledge, no previous research work has been proposed for the exact solution of problem (1) without the employment of projection or discretisation techniques or through a hybrid optimisation scheme. In the present work, we propose a novel algorithm for the exact solution of general mp-MILPs under global uncertainty based on the principles of symbolic manipulation and semi-algebraic geometry. A significant feature of the proposed algorithm lies in the exact computation of non-convex CRs where only one globally optimal explicit solution is stored and no need for online comparison is needed.

The remainder of the article is organised as follows: in Section 2, we introduce the reader to the main concepts that form the basis for the present work. Then we illustrate the main steps of the proposed algorithm while the nature of the optimal explicit solution and the CRs is discussed. To illustrate the solution procedure, in Section 3, a number of examples are solved. Process synthesis and scheduling case studies underline the potential practical value of the proposed algorithm. A short discussion about the computational issues and non-convexity of the problem follows in Section 4. Finally, concluding remarks and future research directions are outlined in Section 5.

2. Methodology

2.1. Gröbner bases theory

The key idea of the proposed algorithm is as follows. Instead of approaching the solution of the mp-P problem numerically we exploit concepts from computer algebra. Upon inspection, problem (1) involves bilinear terms of optimisation variables with uncertain parameters and within the context of computer algebra this can be viewed as a “power-product”. Based on this inspection, Gröbner

bases theory can be employed for the solution of square system of equations that is derived by the 1st order KKT conditions of problem (1). Before we proceed further it is important to provide some formal definitions that are crucial in Gröbner bases theory.

Let  $k$  be any field and let  $k[\mathbf{x}] = k[x_1, \dots, x_t]$  be the ring of polynomials in  $t$  indeterminates. Any polynomial can be described as a sum of terms of the form:  $\alpha x_1^{\beta_1} \dots x_t^{\beta_t}$  with  $\alpha \in k$  and  $\beta_i \in \mathbb{N}$ ,  $i = 1, \dots, t$  and the term  $x_1^{\beta_1} \dots x_t^{\beta_t}$  is called power-product.

**Definition 1.** Gröbner basis (Buchberger, 2006)

A set of non-zero polynomials  $G = \{g_1, \dots, g_t\}$  contained in an ideal  $I$ , is called a Gröbner basis for  $I$  if and only if for all  $f \in I$  such that  $f \neq 0$ , there exists  $i \in \{1, \dots, t\}$  such that  $lp(g_i)$  divides  $lp(f)$ , where  $lp(\cdot)$  stands for the leading power-product of a polynomial function.

In the definition given, an ideal is a set of polynomials of the form  $i = 1 \dots t \sum u_i g_i$  with  $g_i$  in  $G$  and arbitrary polynomials  $u_i$ . The existence of such ideal is guaranteed by the Hilbert Basis theorem (Buchberger and Winkler, 1998), which also guarantees the termination of algorithms that are used for the computation of Gröbner bases.

Roughly speaking, within Gröbner bases theory a set of polynomial  $V$  is transformed into an other set of polynomials  $G$  which is equivalent to the former but has certain favourable computational properties. At the core of Gröbner bases theory the Buchberger algorithm is found (Buchberger, 2006) which is employed for the computation of the Gröbner basis of a specific set of polynomials. Buchberger introduced within the algorithm the concept of S-polynomials as well as provided a theorem for the proposed algorithm which for the sake of space are not discussed in the present article; however, the interested reader can refer to the book of Buchberger and Winkler (1998) for further exposition on the subject. Apart from Buchberger’s algorithm for the computation of Gröbner bases, Faugère devised two algorithms, F4 (Faugere, 1999) and F5 (Faugere, 1998) which compared to Buchberger’s algorithm are computationally more efficient. F4 is based on linear algebra principles where successive truncated Gröbner bases are created and reductions of the polynomials are performed in parallel; within the algorithmic routine a symbolic preprocessing step is included as well as the author adopted the Buchberger’s criteria for the selection of the critical pairs of power-products.

Note, that Mathematica 10, the computer algebra system (CAS) where the proposed algorithm is implemented uses an optimised version of the Buchberger’s algorithm.

2.2. Global uncertainty in general mp-MILPs

Let us consider again the mp-MILPs under global uncertainty. Without loss of generality consider the case where the equality constraints are replaced by opposing inequality constraints thus leading to the form of problem ( $P_{master}$ ).

$$(P_{master}) = \begin{cases} z(\theta) &= \min_{\mathbf{x}, \mathbf{y}} c^T(\theta)\mathbf{x} + d^T(\theta)\mathbf{y} \\ \text{subject to :} & A(\theta)\mathbf{x} + W(\theta)\mathbf{y} \leq \mathbf{b}(\theta) \\ & \mathbf{x} \in X \subseteq \mathbb{R}^{n_x}, \mathbf{y} \in \{0, 1\}^{n_y} \\ & \theta \in \Theta \subseteq \mathbb{R}^{n_\theta} \end{cases} \quad (2)$$

Problem ( $P_{master}$ ) is an mp-MILP that involves uncertain parameters on the RHS, LHS and OFC. The key idea is to treat both the uncertain parameters and the binary variables as symbols and thus reduce ( $P_{master}$ ) to an mp-LP under global uncertainty at the first stage. Another idea would be to follow a decomposition scheme similar to Dua and Pistikopoulos (2000) where the decision maker would iterate between the a Master MILP and slave symbolic mp-LPs; however we do not explore this option in the present work as results from the case studies indicate the dimensionality of the

binary variables do not affect significantly the computational complexity of the proposed scheme. Note that idea for the relaxation of the binary variables as uncertain parameters has been used in some of our previous works (Charitopoulos and Dua, 2016; Charitopoulos et al., 2017b; Dua, 2015; Gueddar and Dua, 2012). Treating the binary variables as uncertain parameters between their respective lower and upper bound results in a relaxed mp-MILP (R-mp-MILP) which can be solved analytically.

$$(R - mpMILP) \begin{cases} z(\theta) = \min_{\mathbf{x}, \mathbf{y}} c^T(\theta)\mathbf{x} + d^T(\theta)\mathbf{y} \\ \text{subject to :} & A(\theta)\mathbf{x} + W(\theta)\mathbf{y} \leq \mathbf{b}(\theta) \\ & \mathbf{x} \in X \triangleq \{x \in \mathbb{R}^{n_x} \mid x_k^{\min} \leq x_k \leq x_k^{\max}, k = 1, \dots, n_x\} \\ & \mathbf{y} \in [0, 1]^{n_y} \\ & \theta \in \Theta \triangleq \{\theta \in \mathbb{R}^{n_\theta} \mid \theta_l^{\min} \leq \theta_l \leq \theta_l^{\max}, l = 1, \dots, n_\theta\} \end{cases} \quad (3)$$

The R-mp-MILP is an augmented mp-P where apart from the uncertain parameters we consider the relaxed binary variables. Formulating the first order KKT conditions for the R-mp-MILP leads to the system of Eq. (4).

$$(P) \begin{cases} \nabla_{\mathbf{x}} L(\mathbf{x}, \mathbf{y}, \theta) = 0 \\ \lambda_j(\mathbf{y}, \theta) (\sum_{k=1}^{n_x} a_{j,k}(\theta)x_k + \sum_{k=1}^{n_y} w_{j,k}(\theta)y_k - b_j(\theta)) = 0, \forall j = 1, \dots, m \end{cases} \quad (4)$$

where  $L(\mathbf{x}, \mathbf{y}, \theta, \lambda) = \mathbf{c}^T(\theta)\mathbf{x} + \mathbf{d}^T(\theta)\mathbf{y} + \lambda^T (\sum_{j=1}^m \sum_{k=1}^{n_x} a_{j,k}(\theta)x_k + \sum_{j=1}^m \sum_{k=1}^{n_y} w_{j,k}(\theta)y_k - b_j(\theta))$  is the Lagrangian function of the R-mp-MILP problem. Solving ( $P$ ) analytically results in the explicit parametric expressions of the optimisation variables, i.e.  $\mathbf{x}(\mathbf{y}, \theta)$  and the Lagrange multipliers, i.e.  $\lambda(\mathbf{y}, \theta)$  which will be used in the next step to evaluate the optimality and feasibility conditions, i.e. the non-negativity of the Lagrange multipliers and the satisfaction of the inactive constraints. The set of solutions computed at this step are called “candidate solutions”. Candidate solutions, include solutions that can be locally or globally optimal or infeasible due to constraint violation or integrality conditions. In the evaluation of the candidate solutions the first step is to consider the non-negativity of the Lagrange multipliers which would lead to the rejection of infeasible solutions. Note that by doing so, we avoid to visit every possible integer node and thus reduce the computational burden. As next step, we impose the integrality conditions on the binary variables, i.e.  $\mathbf{y} \in [0, 1]^{n_y} \rightarrow \mathbf{y} \in \{0, 1\}^{n_y}$ ; as a result now the Lagrange multipliers and the vector of optimisation variables are functions of the uncertain parameters. i.e.  $\mathbf{x}(\theta), \lambda(\theta)$  and the feasibility and optimality qualification is performed so as to compute the final “integer feasible solutions”. Note that at the end of this step, for the “integer feasible solutions” the corresponding CRs are given by the inequality constraints (5) and (6).

$$\lambda_j(\theta) \geq 0, j = 1, \dots, m \implies \text{optimality conditions} \quad (5)$$

$$\mathbf{g}_j(\theta) \leq 0, j = 1, \dots, m \implies \text{feasibility conditions} \quad (6)$$

where  $\mathbf{g}_j(\theta)$  stands for the vector of inequality constraints of problem (R-mpMILP) that is now explicit only in  $\theta$ . If the solution under evaluation is feasible, then the inequality constraints provide a set of parametric inequalities that form the CR of the integer feasible solution.

**Remark 1.** When global uncertainty is considered in mp-MILPs the explicit optimisers and the optimal objective value, i.e.  $\mathbf{x}(\theta)$  and  $z(\theta)$ , are fractional polynomial functions of the uncertain parameters continuous within their respective CR but not necessarily continuous in the entire parametric space. The corresponding CRs are in general non-convex and possibly discontinuous (Charitopoulos et al., 2017a; Wittmann-Hohlbein and Pistikopoulos, 2012a).

Because of the combinatorial nature of the problem, it is common issue mp-P that some CRs may co-exist in the same space

**Table 3**  
Possible outcomes in the definition of  $CR_{INT}$ .

Case 1	$CR_1 \subseteq CR_2$ which means that all constraints of $CR_2$ are redundant and $CR_{INT} = CR_1$
Case 2	$CR_1 \supseteq CR_2$ which means that all constraints of $CR_1$ are redundant and $CR_{INT} = CR_2$
Case 3	The $CR_{INT}$ is defined by a set of active constraints from both $CR_1$ and $CR_2$ as both CRs have some non-redundant constraints

and thus requiring some dominance criterion so as to decide upon the dominant CR in the common parametric space; in this work we follow the same procedure for the comparison and dominance of overlapping CRs from our latest work (Charitopoulos and Dua, 2016; Charitopoulos et al., 2017a).

2.3. Cylindrical algebraic decomposition and comparison of overlapping CRs

Defining redundant constraints and computing the new CRs within the comparison procedure is a non-trivial task, especially for non-convex problems. A comparison procedure for explicit solutions valid in the same parametric space can be found in Acevedo and Pistikopoulos (1997). This procedure is applicable only for the case of convex CRs, i.e. when the CRs are defined as a set of linear inequality constraints. In general, while solving a mp-MILP problem under global uncertainty it can happen that two different parametric solutions, i.e.  $z_1(\theta)$  and  $z_2(\theta)$  to be feasible in the same parametric space. The comparison procedure aims to identify the regions where:

$$z_1(\theta) - z_2(\theta) \leq 0 \tag{7}$$

and

$$z_2(\theta) - z_1(\theta) \leq 0 \tag{8}$$

given that  $z_1(\theta)$  is valid in  $CR_1$  and  $z_2(\theta)$  is valid in  $CR_2$ . The first step is to compute  $CR_{INT} = CR_1 \cap CR_2$ .

2.3.1. Computation of  $CR_{INT}$  and redundant constraints.

Excluding the case that  $CR_{INT} = \emptyset$  there are three possible outcomes in the definition of the  $CR_{INT}$  which are described in Table 3

In Fig. 1 the different cases for the definition of the  $CR_{INT}$  can be envisaged.

For illustration purposes assume that the following two randomly generated CRs, given by Eqs. (9) and (10), are under examination. We have chosen to illustrate a case that one of the CRs is convex the other one non-convex and their overlap ( $CR_{INT}$ ) is non-convex as well, in order to underline the salient feature of the proposed algorithm, i.e. computing exact non-convex CRs. Graphically, in the parametric space  $CR_1$  and  $CR_2$  are presented in Fig. 2.

$$CR_1 = \begin{cases} 0 \leq \theta_1, \theta_2, \theta_3 \leq 1 \\ \theta_1 - \frac{\theta_2}{\theta_1} + 25\theta_3 \geq 25 \end{cases} \tag{9}$$

$$CR_2 = \begin{cases} 0 \leq \theta_1, \theta_2, \theta_3 \leq 1 \\ \theta_3 - \theta_1 \geq 0.5\theta_2 \end{cases} \tag{10}$$

$CR_1$  is non-convex while  $CR_2$  is convex as polyhedral and thus previously proposed methods for computing their potential overlap are not applicable without some kind of convex approximation. Moreover, identifying redundant constraints and computing the “dominant” CRs infers a problem of solving inequalities which are quantified by logical operators ( $\exists, \forall, \wedge, \neg$  etc.). It can be understood that posing the problem of computing the overlap between two CRs is equivalent to posing the question “is there any range of uncertain parameters for which any inequalities that form the CRs are simultaneously satisfied?”. This question can be in turn postulated as the following quantified mathematical formula:  $\{\exists \theta | CR_i \wedge CR_j, \text{ for } i \neq j\}$  where  $\wedge$  stands for the “logical and” operator. One of the most widely known and used algorithms for

the solution of quantified systems of inequalities is the Cylindrical Algebraic Decomposition (CAD) algorithm (Jirstrand, 1995; Strzeboński, 2000). In brief, one by computing the CAD of a system of inequalities after a number of projection in the decision space (the parametric space in the case of interest for the present work) partitions the space into a sets of, typically non-convex, regions where each inequality retains a constant sign. By doing so, one can evaluate whether a set of inequalities is satisfied within certain regions and at the end compute the final solution to the system of inequalities (in our case, a CR itself, an overlap among different CRs or the region of the parametric space where an explicit solution dominates another). For a detailed exposition on the subject of cylindrical algebraic decomposition the interested reader is referred to the tutorial article of Jirstrand (1995).

As mentioned above, in the present work Mathematica was employed for the analytic solution of the mp-MILP under global uncertainty. Specifically, for the comparison procedure the command “Reduce” was employed which involves an implementation of the CAD algorithm. “Reduce” is a command in Mathematica that qualifies sets of conditional arguments within a given set of parameters and computes a new set within which these conditional statements are satisfied. A detailed exposition on the specifics of the function can be found in Strzeboński (2000) where the author details the different strategies employed internally in Mathematica. For example in the definition of the intersection of two CRs ( $CR_{INT}$ ), “Reduce” identifies the redundant constraints of both CRs and computes the region of parametric space where both CRs exists; for the case that the CRs do not overlap the output of “Reduce” is a “False” statement equivalent to the argument  $CR_{INT} = \emptyset$ .

Defining the  $CR_{INT}$  thus infers computing the CAD of the parametric space where both  $CR_1$  and  $CR_2$  are always valid and a part of its mathematical expression is given by Eq. (11). In Fig. 1 the meshed area of the parametric space represents the overlap of the two CRs.

$$CR_{INT} = \begin{cases} 0 < \theta_1 \leq 0.049 \left\{ \begin{aligned} 0 \leq \theta_2 \leq \theta_1(20 + \theta_1) \\ 0.2 - 0.04\theta_1 + \frac{0.04\theta_2}{\theta_1} \leq \theta_3 \leq 1 \end{aligned} \right. \\ 0.049 \leq \theta_1 \leq 0.099 \left\{ \begin{aligned} 0 \leq \theta_2 \leq 1 \\ 0.2 - 0.04\theta_1 + \frac{0.04\theta_2}{\theta_1} \leq \theta_3 \leq 1 \end{aligned} \right. \\ \vdots \\ \vdots \\ 0.5 \leq \theta_1 \leq 1 \left\{ \begin{aligned} 0 \leq \theta_2 < 2 - 2\theta_1 \\ \theta_1 + 0.5\theta_2 \leq \theta_3 \leq 1 \end{aligned} \right. \end{cases} \tag{11}$$

The redundant constraints from each CR can be computed as  $RC_{CR_i} = \{\theta | \theta \in (CR_i \wedge (-CR_{INT}))\}, \forall i = 1, 2$  using CAD computations.

2.3.2. Computation of  $CR_{REST}$  and the final non-overlapping CRs.

After the definition of the  $CR_{INT}$  the dominance criterion can be expressed by the conditional inequality (12).

$$z_1(\theta) - z_2(\theta) \leq 0, \theta \in CR_{INT} \tag{12}$$

As a next step, excluding the case that  $CR_{INT} = \emptyset$ , the comparison procedure is continued and a new set of conditional statements is qualified, given by (12). The output of this step is used so as to define the  $CR_{REST_i}$ , given by (13) and (14), while the two modified CRs after the comparison procedure no longer overlap.

$$CR_{REST_1} = \{\theta | \theta \in (CR_{INT} \wedge (z_1(\theta) \leq z_2(\theta)))\} \tag{13}$$

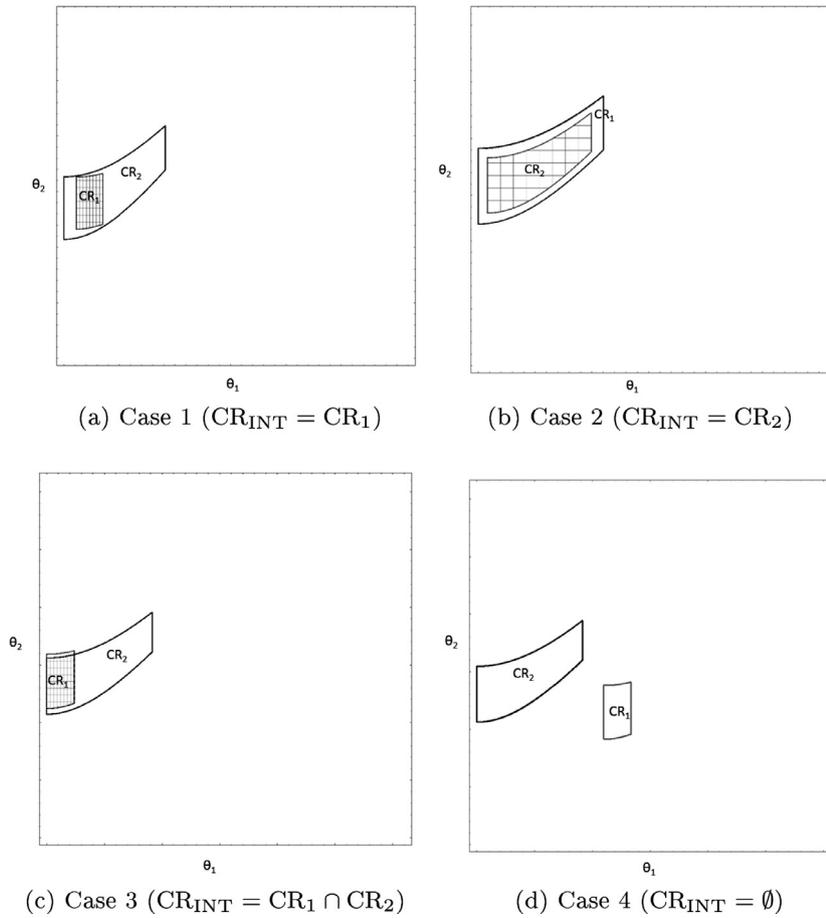

Fig. 1. Definition of  $CR_{INT}$ .

$$CR_{REST_2} = \{\theta \mid \theta \in (CR_{INT} \wedge (z_1(\theta) \geq z_2(\theta)))\} \quad (14)$$

Following the comparison procedure for the previous illustrative case, assume that  $z_1(\theta) - z_2(\theta) = -2\theta_1 - 19\theta_2 + 2\theta_3 - 68$ . In order to identify the dominant solution for the illustrative case

Finally, the two CRs that no longer overlap are presented graphically in Fig. 3, the mathematical expression of  $CR_2$  is given by Eq. (17) while the mathematical expression of  $CR_1$  remains the same as the one given by Eq. (9). Notice that  $z_1(\theta)$  is globally optimal in  $CR_1^{fin}$  and  $z_2(\theta)$  is globally optimal in  $CR_2^{fin}$ .

$$CR_2^{fin} = \begin{cases} \theta_3 \leq 1 & \begin{cases} \theta_1 = 0 & \begin{cases} \theta_2 = 0 & \& \theta_3 \geq 0 \\ 0 \leq \theta_2 \leq 1 & \& 0.5\theta_2 \leq \theta_3 \end{cases} \\ \theta_1 > 0 & \& \theta_1(\theta_1 + 20) < \theta_2 \leq 1 \& \theta_1 + 0.5\theta_2 \leq \theta_3 \end{cases} \\ \theta_2 \geq 0 & \begin{cases} \theta_1 = 0.0498 & \& 0 \leq \theta_2 \leq 1 \& 0.5\theta_2 + 0.0498 \leq \theta_3 < 0.198 + 0.8019\theta_2 \\ 0.04\theta_1 + \theta_3 < 0.2 + \frac{0.04\theta_2}{\theta_1} & \& \theta_1 + 0.5\theta_2 \leq \theta_3 \end{cases} \\ 0 < \theta_1 < 0.0498 & \& \theta_2 = \theta_1(20 + \theta_1) \& \theta_1 + 0.5\theta_2 \leq \theta_3 < 1 \end{cases} \begin{cases} \theta_1 > 0.0992 \& \theta_1(\theta_1(\theta_1 + 0.48\theta_2 - 0.272) - 0.0769\theta_2 + 0.0153) + 0.003\theta_2 < 0 \\ 0 < \theta_1 < 0.0498 \& \theta_2 < \theta_1(\theta_1 + 20) \\ 0.0498 < \theta_1 < 0.0992 \& \theta_2 \leq 1. \end{cases} \end{cases} \quad (17)$$

the related CAD is computed in order to evaluate (12). The output of the “Reduce” in the present case a new set of inequalities, namely  $CR_{REST}$ ; this is the fraction of  $CR_{INT}$  in which  $z_1(\theta) \leq z_2(\theta)$ . More specifically in the case, the explicit solution of  $CR_1$  is always dominant in the overlap of the two CRs and thus  $CR_{REST_1} \equiv CR_{INT}$  while  $CR_{REST_2} = \emptyset$ .

After the  $CR_{REST}$  regions are computed the final CRs can be computed as follows:

$$CR_1^{fin} = \{\theta \mid \theta \in (CR_1 \wedge (-CR_{REST_2}))\} \quad (15)$$

$$CR_2^{fin} = \{\theta \mid \theta \in (CR_2 \wedge (-CR_{REST_1}))\} \quad (16)$$

A flowchart of the main steps for the exact solution of general mp-MILPs under global uncertainty is given in Algorithm 1 while a more elaborate description is given in Algorithm S.2.

**Remark 2.** Note that when LHS uncertainty is considered in the coefficients of the binary variables exact linearisation techniques can be employed to transform the LHS to RHS uncertainty. More specifically, following the Glover transformation (Glover, 1975) the product between an uncertain parameter and a binary variable, for the case of non-negative uncertain parameter, can be expressed with the help of an artificial variable, i.e.  $\theta_{RHS} = \theta \cdot y$ , as:  $(y - 1)\theta^{up} + \theta \leq \theta_{RHS} \leq \theta^{up}$ ,  $\theta_{RHS} \leq \theta$ .

**Algorithm 1:** Algorithm for global mp-MILPs.

**Input:** mp-MILP problem  
**Output:**  $\Omega$ : List of explicit solutions and their corresponding CRs  
**1:**  $(\mathbf{x}(\mathbf{y}, \boldsymbol{\theta}), \boldsymbol{\lambda}(\mathbf{y}, \boldsymbol{\theta}), \mathbf{z}(\mathbf{y}, \boldsymbol{\theta})) \leftarrow (\text{void}, \text{void}, \infty)$   
**2:** LIST  $\leftarrow \emptyset$   
**3:** Formulate the 1<sup>st</sup> order KKT conditions of problem (3)  
**4:** Solve problem (P<sub>1</sub>) using Gröbner Bases for  $(\mathbf{x}(\mathbf{y}, \boldsymbol{\theta}), \boldsymbol{\lambda}(\mathbf{y}, \boldsymbol{\theta}))$   
**5:** if problem (P<sub>1</sub>) is infeasible then :  
**6:**  $\Omega = \emptyset$   
**7:** else :  
**8:** Add  $(\mathbf{x}(\mathbf{y}, \boldsymbol{\theta}), \boldsymbol{\lambda}(\mathbf{y}, \boldsymbol{\theta}))$  to LIST  
**9:** while  $\kappa \leq \text{length}(\text{LIST})$  :  
**10:** for  $j = 1, m$  :  
**11:** Substitute  $(\lambda_j^\kappa(\mathbf{y}, \boldsymbol{\theta}))$  in inequalities (5)  
**12:** if inequalities (5) hold for some  $\boldsymbol{\theta} \in \Theta$  then :  
**13:** Keep element  $(\mathbf{x}^\kappa(\mathbf{y}, \boldsymbol{\theta}), \boldsymbol{\lambda}^\kappa(\mathbf{y}, \boldsymbol{\theta}))$  to LIST  
**14:** else :  
**15:** Remove element  $(\mathbf{x}^\kappa(\mathbf{y}, \boldsymbol{\theta}), \boldsymbol{\lambda}^\kappa(\mathbf{y}, \boldsymbol{\theta}))$  from LIST  
**16:** end if  
**17:** end for  
**18:** end while  
**19:** while  $\kappa \leq \text{length}(\text{LIST})$  :  
**20:**  $\mathbf{y} \in [0, 1]^{n_y} \rightarrow \mathbf{y} \in 0, 1^{n_y}$  (Integrality conditions on  $\mathbf{y}$ )  
**21:** for  $j = 1, m$  :  
**22:** Substitute  $(\mathbf{x}^\kappa(\mathbf{y}, \boldsymbol{\theta}), \boldsymbol{\lambda}_j^\kappa(\mathbf{y}, \boldsymbol{\theta}))$  in inequalities (5) – (6)  
**23:** if inequalities (5) – (6) hold for some  $\boldsymbol{\theta} \in \Theta$  then :  
**24:** for  $\omega = 1, 2^{n_y}$  :  
**25:**  $\text{CR}_\kappa^\omega \triangleq \{\boldsymbol{\theta} \in \Theta \mid \lambda_j^\kappa(\boldsymbol{\theta}) \geq 0 \wedge g_j(\mathbf{x}^\kappa(\boldsymbol{\theta})) \leq 0\}$   
**26:** for each  $\text{CR}_\kappa^\omega$  check  $\text{CR}_\kappa^\omega \cap \text{CR}_{\kappa'}^{\omega'}$  :  
**27:** if  $\text{CR}_\kappa^\omega \cap \text{CR}_{\kappa'}^{\omega'} \neq \emptyset$  then :  
**28:** Perform dominance criterion  
**29:** end if  
**30:** end for  
**31:** Add element  $(\mathbf{x}_\kappa^\omega(\boldsymbol{\theta}), \mathbf{z}_\kappa^\omega(\boldsymbol{\theta}), \text{CR}_\kappa^\omega)$  to  $\Omega$   
**32:** else  $\text{CR}_\kappa^\omega \triangleq \emptyset$  and  $(\mathbf{x}_\kappa^\omega(\boldsymbol{\theta}), \boldsymbol{\lambda}_\kappa^\omega(\boldsymbol{\theta}))$  is infeasible solution  
**33:** end if  
**34:** end for  
**35:** end while  
**36:** end if  
**37:** return  $\Omega$

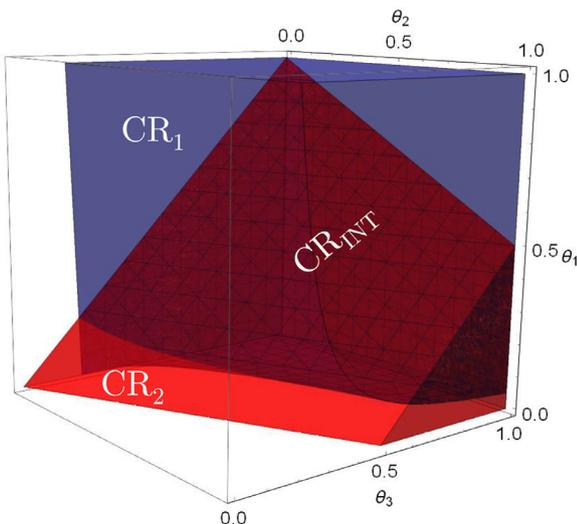

Fig. 2. CR<sub>1</sub> and CR<sub>2</sub> in the parametric space.

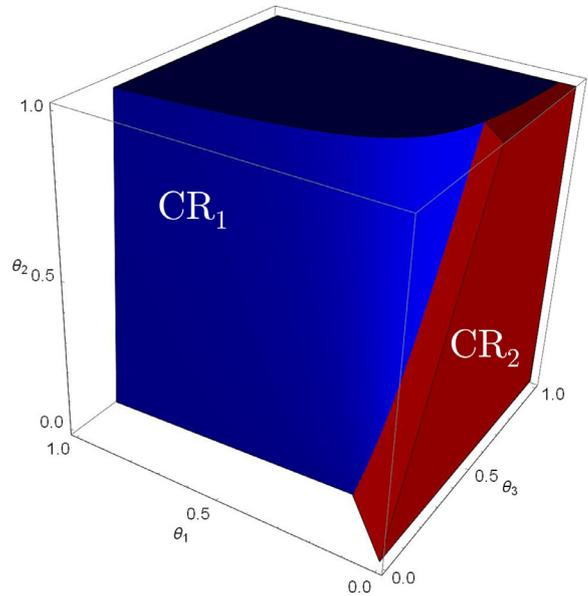

Fig. 3. Final non-overlapping CRs in the parametric space.

**Remark 3.** Note that despite the fact that in the proposed algorithm we refer only to binary variables the algorithm is applicable to integer variables too, as illustrated in a similar work by Dua (2015).

**3. Case studies**

In the present section the main steps of the proposed algorithm are demonstrated on a number of illustrative examples and case studies.

**3.1. Example 1: mp-MILP with LHS uncertainty**

In order to illustrate to applicability of the proposed methodology for the case of mp-MILPs we consider the following mp-MILP problem with LHS uncertainty (Wittmann-Hohlbein and Pistikopoulos, 2012a).

$$\begin{cases}
 z(\boldsymbol{\theta}) = & \min_{\mathbf{x}, \mathbf{y}} (-2x_1 - x_2 + y_1 + y_2) \\
 \text{subject to :} & x_1 + (3 + \theta_1)x_2 + y_1 \leq 9 \\
 & (2 + \theta_2)x_1 + x_2 - y_2 \leq 8 \\
 & x_1 - y_1 + y_2 \leq 4 \\
 & 0 \leq x_1 \leq 4, 0 \leq x_2 \leq 3 \\
 & y_{1,2} \in \{0, 1\}, -10 \leq \theta_{1,2} \leq 10
 \end{cases} \quad (18)$$

Following the proposed algorithm, first the Lagrangian function of problem (18) is formulated as shown in Eq. (19).

$$\begin{aligned}
 L(x_1, x_2, y_1, y_2, \theta_1, \theta_2, \lambda_1, \lambda_2, \lambda_3, \lambda_4, \lambda_5, \lambda_6, \lambda_7) \\
 = -2x_1 - x_2 + y_1 + y_2 + \lambda_1(x_1 + (3 + \theta_1)x_2 + y_1 - 9) \\
 + \lambda_2(2 + \theta_2)x_1 + x_2 - y_2 - 8) + \lambda_3(x_1 - y_1 + y_2 - 4) \\
 + \lambda_4(-x_1) + \lambda_5(-x_2) + \lambda_6(x_1 - 4) + \lambda_7(x_2 - 4)
 \end{aligned} \quad (19)$$

Next, the gradient of the Lagrangian is computed with respect to the optimisation variables, i.e.  $x_1, x_2$  and is given in Eq. (20).

$$\nabla_{x_1, x_2} L = [(\theta_2 + 2)\lambda_2 + \lambda_1 + \lambda_3 - \lambda_4 + \lambda_6 - 2, (\theta_1 + 3)\lambda_1 + \lambda_2 - \lambda_5 + \lambda_7 - 1]^T \quad (20)$$

**Table 4**  
Candidate solutions of LHS – mpMILP.

	$x_1$	$x_2$	$\lambda_1$	$\lambda_2$	$\lambda_3$	$\lambda_4$	$\lambda_5$	$\lambda_6$	$\lambda_7$
1	$\frac{8\theta_1+y_1+\theta_1y_2+3y_2+15}{\theta_1\theta_2+2\theta_1+3\theta_2+5}$	$\frac{9\theta_2-\theta_2y_1-2y_1-y_2+10}{\theta_1\theta_2+2\theta_1+3\theta_2+5}$	$\frac{\theta_2}{\theta_1\theta_2+2\theta_1+3\theta_2+5}$	$\frac{2\theta_1+5}{\theta_1\theta_2+2\theta_1+3\theta_2+5}$	0	0	0	0	0
2	0	$8+y_2$	0	1	0	$\theta_2$	0	0	0
3	4	$y_2-4\theta_2$	0	1	0	0	0	$-\theta_2$	0
4	$y_1-y_2+4$	$-4\theta_2-\theta_2y_1-2y_1+\theta_2y_2+3y_2$	0	1	$-\theta_2$	0	0	0	0
5	$\frac{y_2+8}{\theta_2+2}$	0	0	$\frac{2}{\theta_2+2}$	0	0	$-\frac{\theta_2}{\theta_2+2}$	0	0
6	$\frac{y_2+5}{\theta_2+2}$	3	0	$\frac{2}{\theta_2+2}$	0	0	0	0	$\frac{\theta_2}{\theta_2+2}$
7	4	3	0	0	0	0	0	2	1
8	4	0	0	0	0	0	-1	2	0
9	0	3	0	0	0	-2	0	0	1
10	0	0	0	0	0	-2	-1	0	0
11	$4+y_1-y_2$	3	0	0	2	0	0	0	1
12	$y_1-y_2+4$	0	0	0	2	0	-1	0	0
13	0	$\frac{9-y_1}{\theta_1+3}$	$\frac{1}{\theta_1+3}$	0	0	$-\frac{2\theta_1+5}{\theta_1+3}$	0	0	0
14	4	$\frac{3-y_1}{\theta_1+3}$	$\frac{1}{\theta_1+3}$	0	0	0	0	$\frac{2\theta_1+5}{\theta_1+3}$	0
15	$y_1-y_2+4$	$-\frac{2y_1-y_2-5}{\theta_1+3}$	$\frac{1}{\theta_1+3}$	$\frac{2\theta_1+5}{\theta_1+3}$	0	0	0	0	0
16	$9-y_1$	0	0	0	0	0	$5+\theta_1$	0	0
17	$-y_1-3\theta_1$	3	2	0	0	0	0	0	$-5-2\theta_1$

Note that the components of the gradient of the Lagrangian are explicit in  $\theta$  and  $\lambda$  and also because of the existence of uncertain parameters in the constraint matrix nonlinear products of the form  $\lambda \cdot \theta$  are present. After the gradient of the Lagrangian is computed, the first order KKT conditions are formulated and this results in a square system of 9 equations and 9 unknowns. More specifically,  $n_x$  equations are from the condition that the gradient of the Lagrangian must be zero and  $n_g$  equations are given by the strict complementary slackness conditions. Solving the KKT system, results in 17 candidate solutions as shown in Table 4.

It takes 0.12 s for Mathematica to compute 17 candidate solutions for problem (18) of which, after qualifying with the non-negativity condition of the Lagrange multipliers, the 8th, 9th and 12th candidate solutions are removed from further consideration. By substituting the explicit expressions of the optimisation variables, i.e.  $x_1(\mathbf{y}, \theta)$  and  $x_2(\mathbf{y}, \theta)$ , in the inequality constraints the feasibility of the candidate solutions is examined. At this point, based on the proposed algorithm, the integrality conditions are imposed on the binary variables and this results in the explicit expressions of the optimisation variables and the Lagrange multipliers in  $\theta$  and the 56 solutions that are now left, based on each possible integer combination of the binary variables, are called “integer candidate solutions”. For these solutions, the feasibility and optimality conditions are qualified next. The output of the qualification with the feasibility and optimality conditions can either be an empty set, meaning that the corresponding integer candidate solution is integer infeasible, or a set of parametric inequalities that denote a region in the parametric space. If that region in the parametric space exists, then this is called the CR of the integer feasible solution; otherwise this solution is removed. Because of the combinatorial nature of the problem, some of the feasible solutions after this step were found to overlap and the comparison procedure was employed. The final explicit solution is given in Table 5.

In Fig. 4 the final partition of the parametric space is shown after the comparison procedure so as to highlight that the optimal partition does not consist only of polyhedral regions. This can be further understood by the explicit expressions of the corresponding CRs that involve fractional terms. A visual representation of the optimal objective function in the parametric space is shown in Fig. 5 where the non-convexity of the underlying problem is distinct.

3.2. Example 2: mp-MILP with global uncertainty

Next the following numerical example is considered from Wittmann-Hohlbein and Pistikopoulos (2012b). Uncertainty is con-

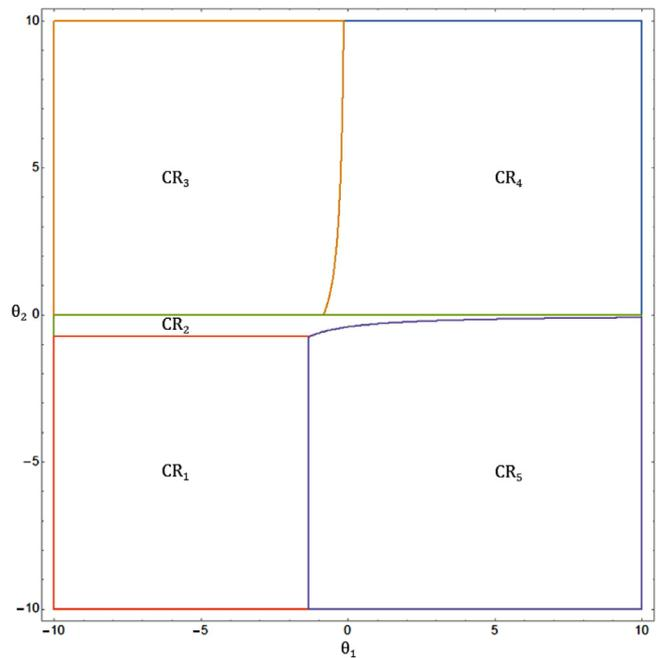

Fig. 4. Final CRs of the LHS-mp-MILP.

sidered in the cost coefficients of both continuous and binary variables, the LHS and the RHS of the constraints.

$$(P_2) := \begin{cases} z(\theta) = & \min_{x,y} (6.4 + 0.25\theta_1)x_1 + 6x_2 \\ & + (7.5 + 0.3\theta_1)y_1 + 5.5y_2 \\ \text{Subject to:} & 0.8x_1 + (0.67 + 0.015\theta_1)x_2 \geq 10 + \theta_2 \\ & x_1 \leq 40y_1 \\ & x_2 \leq 40y_2 \\ & x_{1,2} \geq 0 \\ & y_{1,2} \in \{0, 1\} \\ & -20 \leq \theta_{1,2} \leq 20 \end{cases}$$

Solving the problem based on the proposed algorithm, 8 candidate set of solutions are computed out of which 2 are rejected because of violation of the non-negativity of the Lagrange multipliers. Next, for the remaining six candidate solutions, the integrality conditions are imposed and thus 24 integer candidate solutions arise. Note that after this step, both the Lagrange multipliers and the optimisation variables are explicit functions of the uncertain parameters as shown in Table S.1, for the case that the binary variables are

**Table 5**  
Optimal explicit solutions and CRs of LHS-mp-MILP.

$i$	$y_1$	$y_2$	$x_1^i$	$x_2^i$	$z_i$	$CR_i$
1	0	0	$\frac{(-8\theta_1-15)}{\theta_1\theta_2+2\theta_1+3\theta_2+5}$	$\frac{-9\theta_2-10}{\theta_1\theta_2+2\theta_1+3\theta_2+5}$	$\frac{2(-8\theta_1-15)-9\theta_2-10}{\theta_1\theta_2+2\theta_1+3\theta_2+5}$	$\begin{cases} -\frac{5}{6}\theta_1 \leq \theta_1 \leq 0 \\ 0 \leq \theta_2 \leq \frac{-6\theta_1-5}{3\theta_1} \\ \theta_1 \geq 0 \\ \theta_2 \leq 0 \end{cases}$
2	0	0	4	$-4\theta_2$	$-8+4\theta_2$	$\begin{cases} \theta_1 \leq -\frac{5}{6} \\ 0 \leq \theta_2 \\ -\frac{5}{6}\theta_1 \leq \theta_1 \leq 0 \\ \theta_2 \geq \frac{-6\theta_1-5}{3\theta_1} \end{cases}$
3	0	0	$-\frac{5}{2+\theta_2}$	3	$-3-\frac{10}{2+\theta_2}$	$\begin{cases} \theta_1 \leq -\frac{4}{3} \\ -\frac{4}{3}\theta_1 \leq \theta_2 \leq 0 \\ -\frac{4}{3}\theta_1 \leq \theta_1 \\ -\frac{5}{12+4\theta_1} \leq \theta_2 \leq 0 \end{cases}$
4	0	0	4	3	-11	$\begin{cases} \theta_1 \leq -4 \\ \theta_2 \leq -\frac{4}{3} \end{cases}$
5	0	0	4	$-\frac{5}{3+\theta_1}$	$-8-\frac{5}{3+\theta_1}$	$\begin{cases} \theta_1 \geq -\frac{4}{3} \\ \theta_2 \leq -\frac{5}{12+4\theta_1} \end{cases}$

**Table 6**  
Results of example 2.

(a) Explicit solution of example 2					
	$x_1$	$x_2$	$y_1$	$y_2$	$z(\theta)$
if $[\theta_1, \theta_2] \in CR_1$	0	0	1	0	$0.3\theta_1 + 7.5$
if $[\theta_1, \theta_2] \in CR_2$	0	$\frac{66.67\theta_2+666.67}{\theta_1+44.67}$	0	1	$\frac{5.5\theta_1+400\theta_2+4245.67}{\theta_1+44.67}$
if $[\theta_1, \theta_2] \in CR_3$	$1.25\theta_2 + 12.5$	0	1	0	$0.3125\theta_1\theta_2 + 3.425\theta_1 + 8\theta_2 + 87.5$

(b) Critical regions of example 2	
Critical regions	Mathematical expression
$CR_1 :=$	$\begin{cases} -20 \leq \theta_1 \leq 20 \\ -20 \leq \theta_2 \leq -10 \end{cases}$
$CR_2 :=$	$\begin{cases} 0 \leq \theta_1 \leq 20 \\ -10 \leq \theta_2 \leq -8 \\ -0.0675 \leq \theta_1 \leq 0 \\ -8 \leq \theta_2 \leq \frac{\theta_1(-10.96\theta_1-751.947)+1079.47}{\theta_1(\theta_1+70.2667)-136.533} \end{cases}$
$CR_3 :=$	$\begin{cases} -20 \leq \theta_1 \leq -0.0675 \\ -10 \leq \theta_2 \leq 20 \\ -0.0675 \leq \theta_1 \leq 0 \left\{ \begin{array}{l} \frac{\theta_1(-10.96\theta_1-751.947)+1079.47}{\theta_1(\theta_1+70.2667)-136.533} \leq \theta_2 \leq 20 \\ -10 \leq \theta_2 \leq -8 \end{array} \right. \\ 0 \leq \theta_1 \leq 20 \\ -8 \leq \theta_2 \leq 20 \end{cases}$

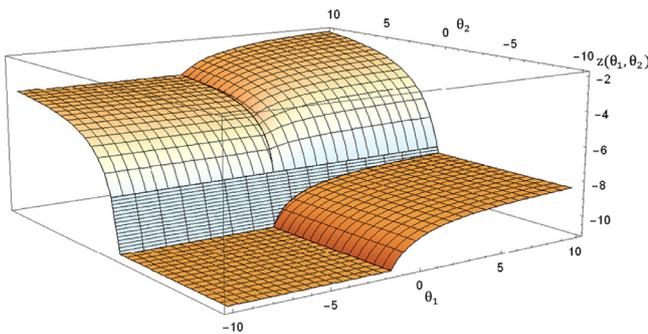

Fig. 5. 3D plot of the optimal objective function in the parametric space.

fixed to be 1. The final explicit results along with the corresponding CRs are given in Table 6

It is interesting to note that the second final parametric solution is discontinuous at  $\theta_1 = 44.667$ . Despite that the present work is based on the grounds of computer algebra and symbolic manipulation, the answer for this discontinuity can be given from a linear algebra perspective. For the second explicit solution, the active constraints are the first one and the non-negativity of  $x_1$ . The cor-

responding technology matrix is given in (21).

$$A_{active} = [-0.8 \quad -0.67 - 0.015\theta_1, -1 \quad 0] \tag{21}$$

Now, if the integrality constraints are dropped and the problem is considered as an LP, for this solution to be basic the matrix, i.e.  $A_{active}$ , has to be invertible and thus its determinant has to be non-zero. For the determinant of (21) to be nonzero it is computed that  $-0.8 + 0.67 + 0.015\theta_1 \neq 0 \rightarrow \theta_1 \neq 44.667$  and justifies why  $z_2$  becomes discontinuous at this point, which however is beyond the examined region for the present case study.

### 3.3. Example 3: mp-MILP global uncertainty

This example is taken from Wittmann-Hohlbein and Pistikopoulos (2012b) and includes uncertain entries in the RHS, OFC and LHS.

$$(P_3) := \begin{cases} z(\theta) = \min_{x,y} \theta_1 x_1 + x_2 + y_1 \\ \text{Subject to : } x_1 + \theta_3 x_2 + x_4 = 1 + \theta_1 y_2 \\ -x_1 + x_2 + x_3 = \theta_2 + 2y_1 \\ y_2 - y_1 \leq 0 \\ x_i \geq 0, \forall i = 1, \dots, 4 \\ y_{1,2} \in \{0, 1\} \\ -5 \leq \theta_{1,2,3} \leq 5 \end{cases}$$

**Table 7**  
Explicit solutions of example 3.

	$x_1$	$x_2$	$x_3$	$x_4$	$y_1$	$y_2$	$z(\theta)$
if $[\theta_1, \theta_2, \theta_3] \in CR_1$	1	0	$\theta_2 + 3$	0	1	0	$\theta_1 + 1$
if $[\theta_1, \theta_2, \theta_3] \in CR_2$	1	0	$\theta_2 + 1$	0	0	0	$\theta_1$
if $[\theta_1, \theta_2, \theta_3] \in CR_3$	$\frac{\theta_1 - \theta_2 \theta_3 - 2\theta_3 + 1}{\theta_3 + 1}$	$\frac{\theta_2 + \theta_3 + 3}{\theta_3 + 1}$	0	0	1	1	$\frac{\theta_1^2 - \theta_1((\theta_2 + 2)\theta_3 - 2) + \theta_2 + \theta_3 + 4}{\theta_3 + 1}$
if $[\theta_1, \theta_2, \theta_3] \in CR_4$	$\frac{-\theta_2 \theta_3 - 2\theta_3 + 1}{\theta_3 + 1}$	$\frac{\theta_2 + 3}{\theta_3 + 1}$	0	0	1	0	$\frac{\theta_1(-\theta_2)\theta_3 - 2\theta_1\theta_3 + \theta_1 + \theta_2 + \theta_3 + 4}{\theta_3 + 1}$
if $[\theta_1, \theta_2, \theta_3] \in CR_5$	$\frac{-\theta_2 \theta_3 - 2\theta_3 + 1}{\theta_3 + 1}$	$\frac{\theta_2 + 1}{\theta_3 + 1}$	0	0	0	0	$\frac{-\theta_1 \theta_2 \theta_3 + \theta_1 + \theta_2 + 1}{\theta_3 + 1}$
if $[\theta_1, \theta_2, \theta_3] \in CR_6$	0	0	$\theta_2 + 2$	0	1	0	1
if $[\theta_1, \theta_2, \theta_3] \in CR_7$	0	0	$\theta_2$	0	0	0	0
if $[\theta_1, \theta_2, \theta_3] \in CR_8$	$-\theta_2 - 2$	0	0	$\theta_2 + 3$	1	0	$-\theta_1 \theta_2 - 2\theta_1 + 1$
if $[\theta_1, \theta_2, \theta_3] \in CR_9$	$-\theta_2$	0	0	$\theta_2 + 1$	0	0	$-\theta_1 \theta_2$

The solution of the problem returns 6 candidate set of solutions and after the integrality conditions are imposed 13 integer candidate solutions are obtained; note that the 13 integer candidate solutions are now parametric only in  $\theta$ . Qualifying with the primal and dual optimality conditions 13 explicit solutions and CRs are computed and the comparison procedure follows next. At this step, a number of different integer solutions were found to be cost-wise identical and thus dominance in these case cannot be proven. For these cases, we investigated two different scenarios where in the first one the solutions of integer vector  $\mathbf{y} = [1 \ 1]$  were preferred to those with integer vector  $\mathbf{y} = [1 \ 0]$  and vice versa but for the sake of space only the first scenario is reported herein in Table 7 and Table S.2. Note that the final explicit solutions are in general fractional polynomial functions of  $\theta$  and the CRs are non-convex with a number of them discontinuous as shown in Fig. 6, e.g.  $CR_9$ .

For the sake of space the mathematical expression of  $CR_5$  is omitted as it was found to be three pages long. The explicit mathematical expressions of the CRs given in Tables S.2–S.4 show that CRs are not necessarily convex while in the present example the order of polynomials involved are up to 3. Finally, it is worth noticing that even though  $CR_4$  and  $CR_5$  are individually fragmented, at the final representation of the parametric space in Fig. S.1 the feasible solution set is compact and the objective function continuous across the different regions.

3.4. Example 4: mp-MILP global

Another example involving global uncertainty was adopted from Dua and Pistikopoulos (2000). The corresponding mp-MILP under global uncertainty is given in  $(P_4)$ .

$$(P_4) := \begin{cases} z(\theta) = & \min_{x,y} -\theta_1 x_1 - 2x_2 + 10y_1 + 5y_2 \\ \text{Subject to :} & x_1 + \theta_3 x_2 \leq 20 \\ & x_1 + 2x_2 \leq 12 \\ & x_1 \leq 10 \\ & x_2 \leq 10 \\ & x_1 \leq 20y_1 \\ & x_2 \leq 20y_2 \\ & x_1 - x_2 \leq \theta_2 - 4 \\ & 1 \leq y_1 + y_2 \\ & x_i \geq 0, \forall i = 1, 2 \\ & y_{1,2} \in \{0, 1\} \\ & 1 \leq \theta_1 \leq 6, 0 \leq \theta_{2,3} \leq 5 \end{cases}$$

Following the proposed algorithm the first order KKT system of equations is solved so as to compute symbolically the optimisation variables and the Lagrange multipliers as functions of the binary variables and the uncertain parameters, i.e.  $x_1, 2(y_1, y_2, \theta_1, \theta_2, \theta_3)$  and  $\lambda_{1,\dots,10}(y_1, y_2, \theta_1, \theta_2, \theta_3)$ , respectively. Note that despite that the optimisation variables are two we seek analytical solution of the Lagrange multipliers thus 12 variables in total. For the specific system of equations, 30 candidate solutions are computed of which 9 are integer feasible and are subsequently examined for overlaps. An example of overlapping solutions is the first candidate solution

for the case that both binary variables are equal to 1, i.e.  $CR_{111}$ , and the ninth candidate integer solution for the binary vector  $[1 \ 0]$ , i.e.  $CR_{910}$ . In Fig. 7 a graphical representation of the two overlapping regions is given where their overlap is marked with gray colour. Once the overlapping regions are identified the comparison procedure is enabled. For this specific case the solution of the solution stored in  $CR_{910}$  was found to be inferior compared to the one stored in  $CR_{111}$  and as a result the overlap ( $CR_{INT}$ ) was subtracted from  $CR_{910}$ . Graphically this procedure is shown in Fig. 8 where from the initial CR the part of the overlap where this CR is inferior is getting cut off and thus resulting in the computation of the new CR. Mathematically, this procedure requires the elimination of the quantifiers in the corresponding Boolean formula and the computation of the semi-algebraic set where the corresponding conditions can be satisfied always.

In order to compute the final globally optimal explicit solutions of the present examples, during the identification of overlapping CRs, 18 comparisons were performed and 4 final solutions are computed. It is worth mentioning that in the present example, some of the solutions with different integer vectors were found to be cost-wise identical and thus the comparison procedure could not prove dominance of either one. In those cases, we decided to keep both of the CRs and after the termination of the algorithm in a post-processing step CRs with identical solutions were merged. The explicit solutions of the example ( $P_4$ ) are given in Table 8 and the corresponding CRs in Table S.5. The graphical partition of the parametric space is envisaged in Fig. S.2.

3.5. Example 5: mp-MILP global

This example involves uncertain parameters in the objective function's coefficient, the right-hand side of the second constraint and for left-hand side uncertainty we consider coefficients of continuous and binary variables. The four uncertain parameters are allowed to vary between 0 and 10.

$$(P_5) := \begin{cases} z(\theta) = & \min_{x,y} (-3 + \theta_1)x_1 - 8x_2 + 4y_1 + 2y_2 \\ \text{Subject to :} & x_1 + x_2 \leq 13 + \theta_2 \\ & (5 + \theta_3)x_1 - 4x_2 \leq 20 \\ & -8x_1 + 22x_2 \leq 121 \\ & x_1 \leq \theta_4 y_1 \\ & x_2 \leq 20y_2 \\ & -4x_1 - x_2 \leq -8 \\ & x_{1,2} \geq 0 \\ & y_{1,2} \in \{0, 1\} \\ & 0 \leq \theta_{1,2,3,4} \leq 10 \end{cases}$$

The first step of the proposed algorithm results in 26 candidate solutions. The final integer feasible solutions are 7. From these, 3 explicit solutions are discarded after the dominance procedure and thus the final optimal explicit solutions are 4 and given in Table 9. The corresponding CRs are given in Table S.6.

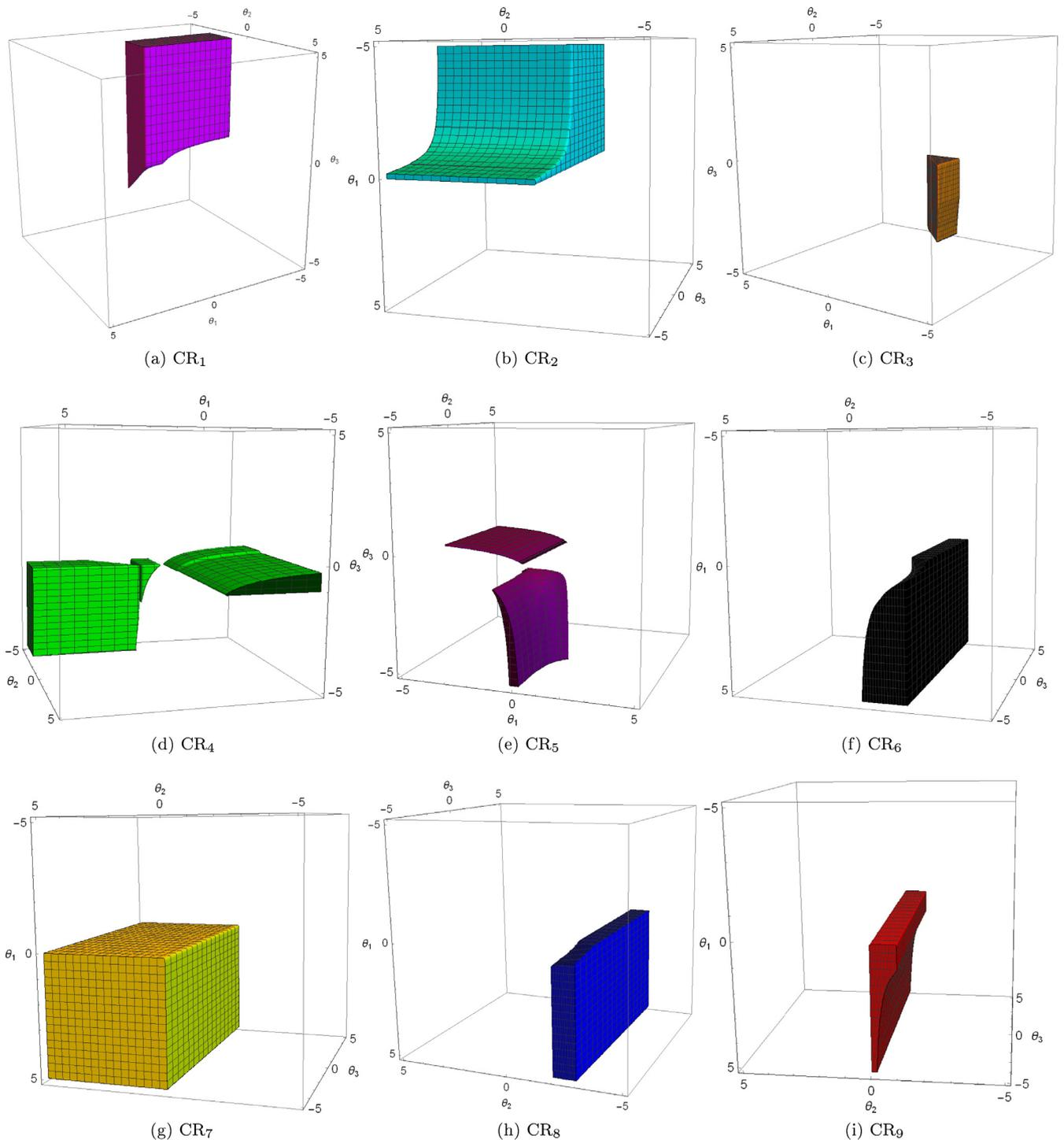

Fig. 6. Critical regions of  $(P_3)$ .

Table 8  
Explicit solutions of  $(P_4)$ .

	$x_1$	$x_2$	$y_1$	$y_2$	$z(\theta)$
if $[\theta_1, \theta_2, \theta_3] \in CR_1$	$\frac{4+2\theta_2}{3}$	$\frac{16-\theta_2}{3}$	1	1	$\frac{1}{3}(-2\theta_1(\theta_2+2)+2\theta_2+13)$
if $[\theta_1, \theta_2, \theta_3] \in CR_2$	$\frac{(\theta_2-4)\theta_2+20}{\theta_2+1}$	$\frac{24-\theta_2}{\theta_2+1}$	0	1	$\frac{-\theta_1((\theta_2-4)\theta_2+20)+2\theta_2+5\theta_3-43}{\theta_2+1}$
if $[\theta_1, \theta_2, \theta_3] \in CR_3$	0	6	0	1	-7
if $[\theta_1, \theta_2, \theta_3] \in CR_4$	0	$\frac{20}{\theta_3}$	0	1	$5-\frac{40}{\theta_3}$

**Table 9**  
Explicit solutions of example 5.

	$x_1$	$x_2$	$y_1$	$y_2$	$z(\theta)$
if $[\theta_1, \theta_2, \theta_3, \theta_4] \in CR_1$	$\frac{461}{39+11\theta_3}$	$\frac{121\theta_1+765}{22\theta_3+78}$	1	1	$\frac{462\theta_1-418\theta_3-4212}{11\theta_3+39}$
if $[\theta_1, \theta_2, \theta_3, \theta_4] \in CR_2$	$\frac{55}{96}$	$\frac{137}{24}$	1	1	$\frac{55\theta_1-3973}{96}$
if $[\theta_1, \theta_2, \theta_3, \theta_4] \in CR_3$	$\frac{11(15+2\theta_2)}{30}$	$\frac{225+8\theta_2}{30}$	1	1	$\frac{(11\theta_1(2\theta_2+15)-5(26\theta_2+423))}{30}$
if $[\theta_1, \theta_2, \theta_3, \theta_4] \in CR_4$	$\theta_4$	$\frac{(121+8\theta_4)}{22}$	1	1	$(\theta_1 - \frac{65}{11})\theta_4 - 38$

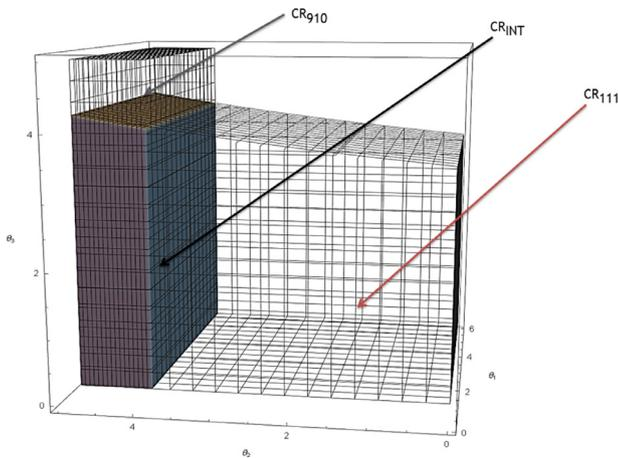

Fig. 7. Instance of overlapping CRs in the parametric space.

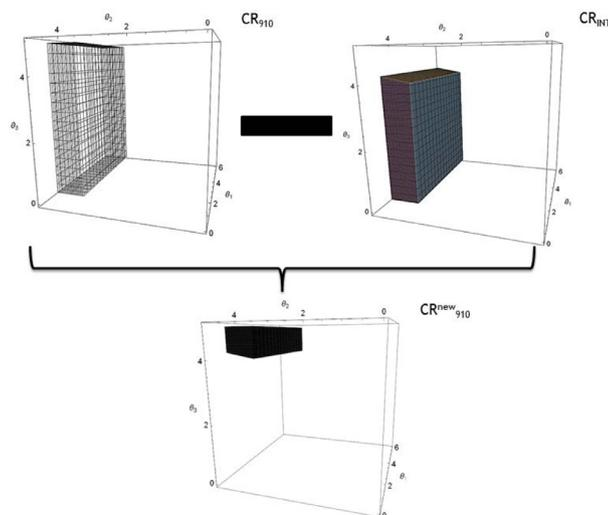

Fig. 8. Graphical illustration of the computation of new CR after the comparison procedure in the parametric space.

### 3.6. Process synthesis under global uncertainty

#### 3.6.1. Case study 1

The present case study deals with the selection between two chemical reactors for the manufacture of a chemical product. Assume that the engineer has to choose between a reactor I, the selection of which is denoted by the binary variable  $y_1$ , that can accomplish higher conversion rate at more cost. The other option is reactor II, the selection of which is denoted by  $y_2$ , that provides lower production yield at lower cost. The aim is to minimise the cost. However, the data that are available are not reliable and thus uncertain parameters have to be considered for the production cost, the production yield and the demand. The problem is

formulated as a mp-MILP under global uncertainty as follows:

$$(P_6) := \begin{cases} z(\theta) = & \min_{x,y} (6.4 + 0.25\theta_1)x_1 + (6 - \theta_6)x_2 \\ & + (7.5 + 0.3\theta_1)y_1 + 5.5y_2 \\ \text{Subject to:} & 0.8x_1 + (0.67 + 0.015\theta_1)x_2 \geq 10 + \theta_2 \\ & \theta_5x_1 \leq \theta_3y_1 \\ & \theta_4x_2 \leq 40y_2 \\ & x_i \geq 0, \forall i = 1, 2 \\ & y_{1,2} \in \{0, 1\} \\ & 2 \leq \theta_1 \leq 10, 0 \leq \theta_2 \leq 10, 0 \leq \theta_3 \leq 200 \\ & 1 \leq \theta_4 \leq 4, 0 \leq \theta_5 \leq 4, 0 \leq \theta_6 \leq 8 \end{cases}$$

The total number of candidate solutions are 8 as shown in Table S.7.

Following the steps of Algorithm 1, 4 integer feasible parametric solutions are found and the final ones are 3. Notice, that although the number of candidate solutions does not grow, the degree of power-products that appear in the optimisers and the Lagrange multipliers grows. The final explicit solutions of the case study 1 are given in Table 10 while the corresponding CRs in Table 11.

#### 3.6.2. Case study 2

The present case study is a variant of a process synthesis problem adopted from Biegler et al. (1997). Within the synthesis problem, uncertainty in process demand, operation cost and conversion rate, namely  $\theta_1, \theta_2$  and  $\theta_3$ , respectively. As shown in figure, the process refers to the production of a chemical C ( $x_5$ ) which can be achieved either through process II or III; for the production of C, a chemical species B ( $x_{2,3}$ ) needs to be converted. B, can be either purchased directly from the market ( $x_4$ ) or manufactured through process I with raw material A ( $x_1$ ) as feed (see Fig. 9).

The corresponding MILP under global uncertainty is formulated as an mp-MILP as follows,

$$(P_7) := \begin{cases} z(\theta) = & \min_{x,y} 2.5x_1 + (4 + \theta_1)x_2 + 5.5x_3 + 10y_1 \\ & + 15y_2 + 20y_3 - 18x_5 \\ \text{Subject to:} & 0.9x_1 - x_2 - x_3 + x_4 = 0 \\ & x_5 = 0.82x_2 + \theta_3x_3 \\ & 2 \leq x_5 \leq 5 + \theta_2 \\ & x_1 \leq 16y_1 \\ & x_2 \leq 30y_2 \\ & x_3 \leq 30y_3 \\ & y_2 + y_3 \geq 1 \\ & x_4 \leq 14 \\ & 0.4x_1 \leq 5 + \theta_2 \\ & x_i \geq 0, \forall i = 1, \dots, 5 \\ & y_i \in \{0, 1\}, \forall i = 1, 2, 3 \\ & 0 \leq \theta_1 \leq 5 \\ & 0 \leq \theta_2 \leq 5 \\ & 0.75 \leq \theta_3 \leq 0.95 \end{cases}$$

The LHS uncertainty involved in  $(P_7)$  is located in the second equality constraint and represents uncertainty in the conversion coefficient. Solving problem  $(P_7)$  results in 97 candidate solutions. Evaluating with the optimality and integrality conditions results in 3 integer feasible solutions. Two of these solutions are found to

**Table 10**  
Explicit solutions of case study 1.

	$x_1$	$x_2$	$y_1$	$y_2$	$z(\theta)$
if $[\theta_1, \theta_2, \theta_3, \theta_4, \theta_5, \theta_6] \in CR_1$	$\frac{1.25(\theta_2\theta_4+10\theta_4)}{\theta_4}$	0	1	0	$\frac{1.25(0.25\theta_1+6.4)(\theta_2\theta_4+10\theta_4)}{\theta_4} + 0.3\theta_1 + 7.5$
if $[\theta_1, \theta_2, \theta_3, \theta_4, \theta_5, \theta_6] \in CR_2$	$\frac{1.25(\theta_2\theta_4+10\theta_4)}{\theta_4}$	0	0	0	$\frac{1.25(0.25\theta_1+6.4)(\theta_2\theta_4+10\theta_4)}{\theta_4}$
if $[\theta_1, \theta_2, \theta_3, \theta_4, \theta_5, \theta_6] \in CR_3$	0	$\frac{40}{\theta_4}$	0	1	$\frac{5.5\theta_4-40}{\theta_4} + \frac{\theta_5}{\theta_4} + 2.40$

**Table 11**  
Critical regions of case study 1.

Critical regions	Mathematical expression
$CR_1 :=$	$\left\{ \begin{array}{l} 2 \leq \theta_1 \leq 10 \\ \theta_2 \leq 10 \\ 0 \leq \theta_3 \leq 5 \\ \theta_4 \leq 4 \\ 0 < \theta_5 \\ 0 \leq \theta_6 \end{array} \right\} \left\{ \begin{array}{l} \frac{26.8+0.6\theta_1}{10+\theta_2} < 4 \\ \theta_6 \leq 8 \end{array} \right\} \left\{ \begin{array}{l} \theta_5 \leq 4 \\ 50 + 5\theta_2 \leq \theta_3 \leq 200 \\ 0 < \theta_3 \leq 50 + 5\theta_2 \\ \theta_5 \leq \frac{0.22518\theta_3}{2.81475(1+0.1\theta_2)} \end{array} \right\}$
$CR_2 :=$	$\left\{ \begin{array}{l} 2 \leq \theta_1 \leq 10 \\ 0 \leq \theta_2 \leq 10 \\ 0 \leq \theta_3 \leq 200 \\ \frac{134+3\theta_1}{50+5\theta_2} \leq \theta_4 \leq 4 \\ \theta_5 = 0 \\ 0 \leq \theta_6 \leq 8 \end{array} \right\}$
$CR_3 :=$	$\left\{ \begin{array}{l} 2 \leq \theta_1 \leq 10 \\ 0 \leq \theta_2 \leq 10 \\ 0 \leq \theta_3 \leq 200 \\ 1 \leq \theta_4 \leq \frac{134+3\theta_1}{50+5\theta_2} \\ 0 \leq \theta_5 \leq 4 \\ 6 \leq \theta_6 \leq 8 \end{array} \right\}$

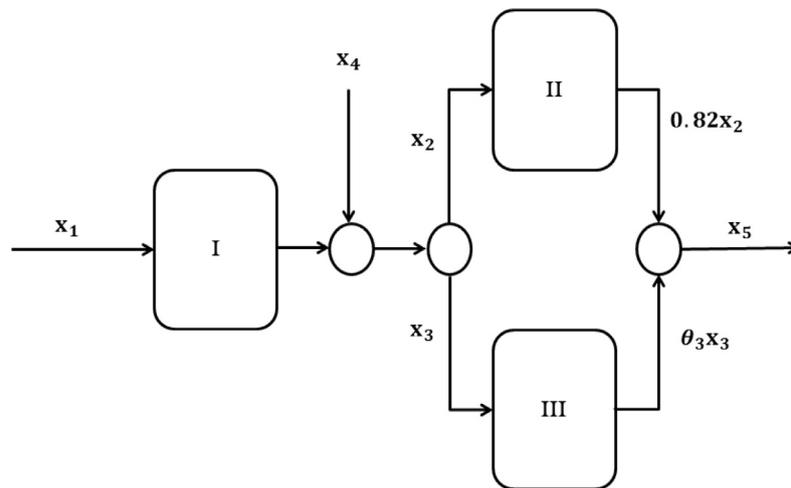

**Fig. 9.** Superstructure of case study 2.

overlap and the comparison procedure is employed, resulting in two final optimal solutions which are given in Table 12 along with their corresponding CRs.

3.7. Process scheduling under global uncertainty

In order to illustrate the generality and applicability of the proposed algorithm the case of process scheduling under global uncertainty is examined. Scheduling problems have been studied in the past using multi-parametric programming techniques (Li and Ierapetritou, 2007b; Ryu et al., 2007; Wittmann-Hohlbein and Pis-

tikopoulos, 2012b), however the case of simultaneous variations on the LHS, RHS and OFC has yet to be treated.

Our point of departure is the multi-stage zero-wait batch scheduling problem formulation as proposed by Ryu et al. (2007). The model employs a time slot based formulation for the sequencing decisions among different products. At each time slot (s) only one product (i) can be manufactured and the corresponding assignment is modelled using the binary variable  $y_{si}$ . The model assumes unlimited intermediate storage and thus the objective is to minimise the makespan of the process ( $C_{N,J}$ ).

$$z(\theta) = \min C_{S,J} \tag{22}$$

**Table 12**  
Explicit results of ( $P_7$ ).

$i$	$x_1^i$	$x_2^i$	$x_3^i$	$x_4^i$	$x_5^i$	$y_1^i$	$y_2^i$	$y_3^i$	$z_i$	$CR_i$
1	0	0	$1.0526\theta_2 + 5.2631$	$1.0526\theta_2 + 5.2631$	$5 + \theta_2$	0	0	1	$-12.21\theta_2 - 41.052$	$\left\{ \begin{array}{l} 0 \leq \theta_2 \leq 5 \\ 0.75 \leq \theta_3 \end{array} \right\} \left\{ \begin{array}{l} 0.342 \leq \theta_1 \leq 1.5 \\ \theta_3 \leq 0.691 + 0.173\theta_1 \\ 1.5 \leq \theta_1 \leq 5 \\ \theta_3 \leq 0.95 \end{array} \right.$
2	0	$\frac{(\theta_2+5)}{\theta_3}$	0	$\frac{(\theta_2+5)}{\theta_3}$	$5 + \theta_2$	0	1	0	$\frac{(\theta_1+4)(\theta_2+5)}{\theta_3} - 18\theta_2 - 75$	$\left\{ \begin{array}{l} 0 \leq \theta_2 \leq 5 \\ 0.75 \leq \theta_3 \leq 0.95 \end{array} \right\} \left\{ \begin{array}{l} 0.342 \leq \theta_1 \leq 1.5 \\ 0.691 + 0.173\theta_1 \leq \theta_3 \leq 0.95 \\ 0 \leq \theta_1 \leq 0.342 \\ 0.75 \leq \theta_3 \leq 0.95 \end{array} \right.$

Subject to : (23)

$$\sum_s^N y_{si} = 1 \quad \forall i \quad (24)$$

$$\sum_i^N y_{si} = 1 \quad \forall s \quad (25)$$

$$C_{sj} \geq C_{s,j-1} + \sum_i^N y_{si} P_{ij} \quad \forall j > 1, i \quad (26)$$

$$C_{sj} \geq C_{s-|j|,j} + \sum_i^N y_{si} P_{ij} \quad \forall i \geq |j|, j \quad (27)$$

$$C_{sj} \geq 0 \quad (28)$$

$$y_{si} \in \{0, 1\} \quad (29)$$

Eqs. (24) and (25) are used to ensure that only one product can be processed at a time in each stage while Eqs. (26) and (27) are employed to compute the completion time of the time slot  $s$  in stage  $j$  ( $C_{sj}$ ). The processing time of product  $i$  in stage  $j$  ( $P_{ij}$ ) is considered as uncertain while equipment availability can be included by adding a new vector of uncertain parameters on the RHS of Eqs. (26) and (27). Another type of uncertainty on the LHS of Eqs. (26) and (27) can be included if a time proportional to the completion time is considered as a buffer for maintenance or other reason, i.e.  $\theta_{sj} C_{sj}$ .

3.7.1. Two-stage scheduling problem under global uncertainty

Initially we consider only 3 products and 2 stages (instance  $P_8$ ) with the corresponding data given in the supplementary material in Table S.8. It is assumed that the processing time for product B at stage  $j_2$  is uncertain and uniformly distributed as  $4 \leq \theta_1 \leq 8$ . There exist two “buffer” times proportional to the completion time of the third slot of the first stage ( $C_{s3j1}$ ) and the first time slot of second stage ( $C_{s1j2}$ ) both uniformly distributed as  $0.8 \leq \theta_{2,3} \leq 1.2$ . Following the proposed algorithm in 2.46 s, four globally optimal explicit solutions are found and their expressions are given Table S.9. As shown in Table S.9 two optimal integer configurations of the schedule are computed throughout the range of parameter variability:  $C \rightarrow A \rightarrow B$  and  $B \rightarrow A \rightarrow C$ ; insights like this are of great importance for responsive and effective process operations as it becomes explicitly known that even if there is a significant degree of variability in the processing time of product B there is no need to change the task sequencing.

The use of multi-parametric programming in scheduling problems is appealing due to the ability to compute offline schedules that can be readily employed once the uncertainty is realised, thus

**Table 13**  
Effect of the dimensionality of the uncertain parameters ( $n_\theta$ ) on the number of CRs computed ( $n_{CR}$ ) and the solution time.

$n_\theta$	$n_{CR}$	CPU (s)
2	1	3.83
3	4	8.46
4	4	9.24
5	5	11.56
6	5	240.38

leading to more responsive operations. To this end, the effect of the dimensionality of uncertain parameters on the solution time of the proposed algorithm was examined and the corresponding results are shown in Table 13.

Breaking down the computational burden associated with the dimensionality of the uncertain parameters it should be highlighted that the CPU time (s) needed by the first computational step of the algorithm is not affected (computation of the candidate solutions). However, the second major computational step (computation of the CRs and the comparison procedure) scales quite quickly.

Next, the case of 5 products scheduling of the two stage manufacturing process was studied in order to test the proposed algorithm for the case of increased dimensionality of the integer vector. This instance ( $P_9$ ), involves 25 binary variables, 21 constraints and 31 continuous variables and in 4,048.3 s a total of 234,600 candidate solutions were computed out of which 25,920 candidate solutions were linearly independent and thus considered for the next steps of the algorithm. The computation of the integer feasible candidate solutions returns 1136 explicit solutions together with the related CRs in 1900 s. The final partition of the parametric space involves 3 overlapping CRs with explicit solutions that result in the same explicit objective value,  $C_{sj}(\theta) = 21 + \theta_2$  and thus no CR can be proven to be dominant. The sequencing decisions involved in the overlapping CRs are two alternatives, more specifically, the two integer optimal sequences are:  $D \rightarrow E \rightarrow C \rightarrow A \rightarrow B$  and  $D \rightarrow A \rightarrow C \rightarrow E \rightarrow B$ . The explicit solutions are given in Table S.10.

3.7.2. Multi-objective three stage scheduling problem under global uncertainty

Finally, the scheduling of a 3 stage process as indicated in Fig. 10 was examined. Related data and a more detailed description of case study can be found in the work of Ryu et al. (2007).

The manufacture of four products was considered and the uncertainty has as follows :  $\theta_1 \in [10, 15]$  as the processing time of product B in stage 2,  $\theta_2 \in [0.9, 1.1]$  to model the possibility of a buffer time that is proportional to the completion time of time slot 4 in stage 1,  $\theta_3 \in [0, 4]$  to model equipment availability of the mixer and finally we consider a modification of the objective in a weighted sum multi-objective sense where  $\theta_4 \in [0, 1]$  indicates the

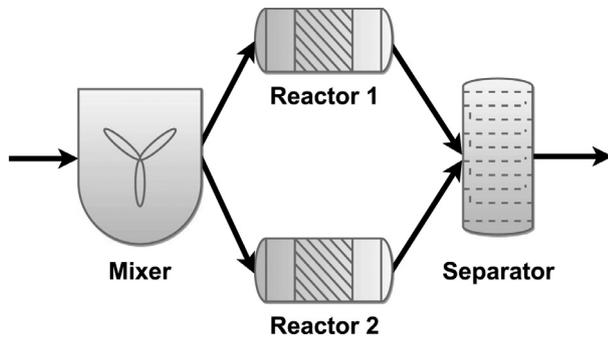

Fig. 10. 3 stage process for scheduling.

Table 14

Multi-parametric expressions of the weighted sum objective function of the three stage scheduling problem along with the related sequencing decisions.

CR <sub>1</sub>	ABCDE	CR <sub>13</sub>	$12(1 - \theta_4) - \frac{\theta_4(-\theta_1-\theta_3-16)}{\theta_2}$	ABCD
CR <sub>2</sub>	ABDCE	CR <sub>14</sub>		ABEDC
CR <sub>3</sub>	ABCDE	CR <sub>15</sub>	$6(1 - \theta_4) - \frac{(-\theta_2-42)\theta_4}{\theta_2}$	BADEC
CR <sub>4</sub>	ABCDE	CR <sub>16</sub>		BAECD
CR <sub>5</sub>	ACBDE	CR <sub>17</sub>	$6(1 - \theta_4) - \frac{(-\theta_2-38)\theta_4}{\theta_2}$	CADBE
CR <sub>6</sub>	$\frac{41\theta_4}{\theta_2} + 14(1 - \theta_4)$	ACDEB		CAEBD
CR <sub>7</sub>	ACDBE	CR <sub>19</sub>	$6(1 - \theta_4) - \frac{\theta_4(-\theta_1-\theta_3-20)}{\theta_2}$	ACEDB
CR <sub>8</sub>	ABCDE	CR <sub>20</sub>		ACEDB
CR <sub>9</sub>	ABCDE	CR <sub>21</sub>	$12(1 - \theta_4) - \frac{\theta_4(-\theta_1-\theta_3-16)}{\theta_2}$	ABEDC
CR <sub>10</sub>	ACBDE	CR <sub>22</sub>		ABEDC
CR <sub>11</sub>	ACDEB	CR <sub>23</sub>		ABCED
CR <sub>12</sub>	ACDBE	CR <sub>24</sub>		ABEDC

different preferences of the decision maker with respect to minimising the completion time of the fourth time slot of stages 3 and 1. The algebraic model with the incorporated uncertainty is given by Eqs. (S.1)–(S.13) and can be found in the supplementary material. Following the proposed algorithm, the KKT system is solved and 688,320 candidate solutions are returned in 13781.9 s. Some of the solutions involve linearly dependent solutions sets, by neglecting these solutions the final full-dimensional candidate solutions are 36,863 which are explicit only in  $(\theta, \mathbf{y})$ . Screening the candidate solutions for dual and primal feasibility and computing their CRs takes 808.78 s and the output involves 144 CRs. After 177.4 s the comparison procedure has removed overlapping CRs that can be proven to be inferior and the final optimal explicit solution involves 24 CRs and the corresponding multi-parametric expressions of the optimisers. In Table 14 the explicit weighted sum function is given along with the related scheduling sequence.

An example of the mathematical expressions that define the related CRs is given in Eq. (30), for the case of CR<sub>22</sub>.

$$CR_{22} := \begin{cases} 0.9 \leq \theta_2 \leq 1.1 \\ \frac{\theta_2}{\theta_2+0.67} \leq \theta_4 \leq 1 \\ 0 \leq \theta_3 \leq 12 - \theta_1 \\ 10 \leq \theta_1 \leq 12 \end{cases} \quad (30)$$

#### 4. Discussion

Having demonstrated the main computational steps and applicability of the proposed algorithm in the following section a discussion on computational issues and the non-convexity of the underlying optimisation problem is presented.

##### 4.1. Computational statistics

Computing the exact explicit solution for mp-MILPs under global uncertainty is one of the most general and challenging problems and as a result it is computationally intensive. In the current

Table 15

Computational statistics of the proposed algorithm with respect to the dimensionality of the inequality constraints ( $n_g$ ), continuous variables ( $n_x$ ), binary variables ( $n_y$ ) and uncertain parameters ( $n_\theta$ ).

	$n_g$	$n_x$	$n_y$	$n_\theta$	Candidate solutions	Total CPU (s)
$P_1$	7	2	2	2	17	0.35
$P_2$	5	2	2	2	8	0.18
$P_3$	7	4	2	3	6	1.24
$P_4$	10	2	2	3	30	2.54
$P_5$	8	2	2	4	26	1.95
$P_5$	5	2	2	6	8	1.46
$P_7$	15	5	3	3	97	15.41
$P_8$	11	17	9	5	202	8.46
$P_9$	21	31	25	3	25,920	5948.3
$P_{10}$	23	35	16	4	36,863	14768.08

work, the proposed algorithm was tested on a number of numerical examples and two case studies of small scale. In Table 15, a summary of the problems' statistics is provided along with the number of candidate solutions that are found.

The number of candidate solutions that are parametric in  $\mathbf{y}$  and  $\theta$  grows rapidly with the number of constraints and continuous variables with more dependence on the number of constraints. On the other hand, as illustrated in the case studies, the number of uncertain parameters and binary variables does not affect the scalability of the proposed algorithm and the reason is twofold: (i) within the proposed algorithm both of them are treated as symbols until a certain step, leaving the initial computation of the candidate solutions unaffected; (ii) for the candidate solutions computed, not all the integer nodes are explored as some of them are rejected based on the primal or dual feasibility conditions of the problem.

Especially for the first example the proposed algorithm required less than 20 comparisons between overlapping solutions while the same example for half range of uncertainty required in the best case the solution of 3331 MINLPs and one mp-LP following the algorithm proposed in Wittmann-Hohlbein and Pistikopoulos (2012a). This leads to significant reduction in computational effort in comparison to approximation based techniques presented in the literature

##### 4.2. Non-convexity of the underlying problem

As introduced in the "Problem statement" section and illustrated through the case studies, the underlying optimisation problem can be highly non-convex. The main reason is the presence of bilinear terms that appear as product between the uncertain parameters and the continuous/integer variables. As illustrated in Wittmann-Hohlbein and Pistikopoulos (2012b), in order to overcome this issue, global optimisation techniques should be employed that could lead to computationally intractable problems for a modest size example. The case of bilinear terms is undoubtedly one of the most well studied problem in the global optimisation literature and remains still a rather active field of research because of its frequent occurrence as part of important applications. In our present work, we elegantly circumvent the treatment of bilinear terms through symbolic manipulation of the uncertain parameters. Furthermore, as shown, the problem can be discontinuous at some instances which further exacerbates the computational effort required.

Although bilinear terms pose a tough difficulty in the solution of mp-MILPs under global uncertainty, a possibly even more tough problem nested within the solution is the definition of overlapping CRs and the comparison procedure that needs to be employed for its treatment. As discussed previously, in the most general case the optimisers and thus the optimal explicit value is a fractional poly-

nomial function of the uncertain parameters. Previous works have proposed to store overlapping solutions in “parametric envelopes” where two solutions are stored and the best one is chosen via on-line function evaluation. Although this could be a possible solution, it is not the optimal one as it still requires an additional evaluation procedure for the decision maker. In order to overcome this issue, we do not consider the conventional polyhedral based definition of CRs but we generalised the their nature as “semi-algebraic sets”. Defining the CRs as semi-algebraic sets where a certain number of conditions hold, in conjunction with the symbolic manipulation we are able to efficiently compare overlapping solutions, characterising the overlap and most importantly computing the exact non-convex CRs. This is due to the fact that a semi-algebraic set can be manipulated in a disjunctive way and thus divide a large complex CR into more simple one to ease the complexity of the calculations and at the end reconnect them as a union.

## 5. Concluding remarks and future research direction

In this work we presented a novel algorithm for the solution of general mp-MILPs that are subject to global uncertainty. We presented through a number of case studies the applicability and generality of the proposed framework as well as some instances that the proposed framework outperforms in accuracy and/or computational complexity other algorithms in the literature. Using symbolic manipulation software to analytically solve the system of equations derived by the first order KKT conditions, the exact solution of the general mp-MILPs was computed together with the corresponding non-convex CRs. The algorithm scales reasonably with the dimensionality of the binary variables and the uncertain parameters for the cases presented. However, the current bottleneck is that the number of initial candidate solutions grows rapidly with the number of constraints and variables. Current developments in symbolic manipulation, solution of polynomial equations as well as parallel computing are expected to benefit the practical value of this algorithm. The fractional polynomial nature of the exact explicit solution poses another major challenge as the degree of polynomials encountered grows with the dimensionality of the parametric vector.

Current research in our group is targeted towards the development of hybrid schemes for problems under global uncertainty that could lead to computationally less intensive solution procedures. The findings of present work will be used to study the structure of the underlying optimisation problem and aid towards further improvements, while a more efficient implementation of the proposed algorithm in a tailored programming environment is an on-going work.

## Acknowledgements

The authors gratefully acknowledge financial support from EPSRC grants EP/M027856/1 and EP/M028240/1.

## Supplementary material

Supplementary material associated with this article can be found, in the online version, at [10.1016/j.compchemeng.2018.04.015](https://doi.org/10.1016/j.compchemeng.2018.04.015).

## References

- Acevedo, J., Pistikopoulos, E.N., 1997. A multiparametric programming approach for linear process engineering problems under uncertainty. *Ind. Eng. Chem. Res.* 36 (3), 717–728.
- Acevedo, J., Pistikopoulos, E.N., 1999. An algorithm for multiparametric mixed-integer linear programming problems. *Oper. Res. Lett.* 24 (3), 139–148.
- Acevedo, J., Salgueiro, M., 2003. An efficient algorithm for convex multiparametric nonlinear programming problems. *Ind. Eng. Chem. Res.* 42 (23), 5883–5890.
- Apap, R.M., Grossmann, I.E., 2017. Models and computational strategies for multi-stage stochastic programming under endogenous and exogenous uncertainties. *Comput. Chem. Eng.* 103, 233–274.
- Bemporad, A., Morari, M., Dua, V., Pistikopoulos, E.N., 2002. The explicit linear quadratic regulator for constrained systems. *Automatica* 38 (1), 3–20.
- Ben-Tal, A., Nemirovski, A., 2002. Robust optimization—methodology and applications. *Math. Program.* 92 (3), 453–480.
- Bertsimas, D., Sim, M., 2004. The price of robustness. *Oper. Res.* 52 (1), 35–53.
- Biegler, L.T., Grossmann, I.E., Westerberg, A.W., 1997. *Systematic Methods for Chemical Process Design*. Prentice Hall, Old Tappan, NJ.
- Birge, J., Louveaux, F., 2011. *Introduction to Stochastic Programming*. Springer Science & Business Media.
- Borrelli, F., Bemporad, A., Morari, M., 2003. Geometric algorithm for multiparametric linear programming. *J. Optim. Theory Appl.* 118 (3), 515–540.
- Buchberger, B., 2006. An algorithm for finding the basis elements of the residue class ring of a zero dimensional polynomial ideal. *J. Symb. Comput.* 41 (3), 475–511.
- Buchberger, B., Winkler, F., 1998. *Gröbner Bases and Applications*, 251. Cambridge University Press.
- Charitopoulos, V.M., Dua, V., 2016. Explicit model predictive control of hybrid systems and multiparametric mixed integer polynomial programming. *AIChE J.* 62 (9), 3441–3460.
- Charitopoulos, V.M., Dua, V., 2017. A unified framework for model-based multi-objective linear process and energy optimisation under uncertainty. *Appl. Energy* 186, 539–548.
- Charitopoulos, V.M., Papageorgiou, L.G., Dua, V., 2017a. Multi-parametric linear programming under global uncertainty. *AIChE J.* 63 (9), 3871–3895.
- Charitopoulos, V.M., Papageorgiou, L.G., Dua, V., 2017b. Nonlinear model-based process operation under uncertainty using exact parametric programming. *Engineering* 3 (2), 202–213.
- Dua, V., 2000. Parametric programming techniques for process engineering problems under uncertainty. Imperial College London.
- Dua, V., 2015. Mixed integer polynomial programming. *Comput. Chem. Eng.* 72, 387–394.
- Dua, V., Bozinis, N.A., Pistikopoulos, E.N., 2002. A multiparametric programming approach for mixed-integer quadratic engineering problems. *Comput. Chem. Eng.* 26 (4), 715–733.
- Dua, V., Papalexandri, K.P., Pistikopoulos, E.N., 2004. Global optimization issues in multiparametric continuous and mixed-integer optimization problems. *J. Global Optim.* 30 (1), 59–89.
- Dua, V., Pistikopoulos, E.N., 1998. An outer-approximation algorithm for the solution of multiparametric MINLP problems. *Comput. Chem. Eng.* 22, 955–958.
- Dua, V., Pistikopoulos, E.N., 1999. Algorithms for the solution of multiparametric mixed-integer nonlinear optimization problems. *Ind. Eng. Chem. Res.* 38 (10), 3976–3987.
- Dua, V., Pistikopoulos, E.N., 2000. An algorithm for the solution of multiparametric mixed integer linear programming problems. *Ann. Oper. Res.* 99 (1–4), 123–139.
- Faisca, N.P., Kosmidis, V.D., Rustem, B., Pistikopoulos, E.N., 2009. Global optimization of multi-parametric MILP problems. *J. Global Optim.* 45 (1), 131–151.
- Faugere, J.C., 1998. Computing Gröbner Basis without reduction to zero (F5). Technical Report. Technical report, LIP6.
- Faugere, J.C., 1999. A new efficient algorithm for computing gröbner bases (F4). *J. Pure Appl. Algebr.* 139 (1), 61–88.
- Fiacco, A.V., 1990. Global multi-parametric optimal value bounds and solution estimates for separable parametric programs. *Ann. Oper. Res.* 27 (1), 381–395.
- Filippi, C., 2004. An algorithm for approximate multiparametric linear programming. *J. Optim. Theory Appl.* 120 (1), 73–95.
- Fotiou, I.A., Rostalski, P., Parrilo, P.A., Morari, M., 2006. Parametric optimization and optimal control using algebraic geometry methods. *Int. J. Control* 79 (11), 1340–1358.
- Gal, T., 1975. RIM Multiparametric linear programming. *Manag. Sci.* 21 (5), 567–575.
- Gal, T., 1995. Postoptimal analyses, parametric programming and related topics. Walter de Gruyter.
- Gal, T., Nedoma, J., 1972. Multiparametric linear programming. *Manag. Sci.* 18 (7), 406–422.
- Gass, S.I., Saaty, T.L., 1955. The computational algorithm for the parametric objective function. *Nav. Res. Log.* 2 (1–2), 39–45.
- Gass, S.I., Saaty, T.L., 1955. Parametric objective function (part 2)—generalization. *Oper. Res.* 3 (4), 395–401.
- Geoffrion, A.M., Nauss, R., 1977. Parametric and postoptimality analysis in integer linear programming. *Manag. Sci.* 23 (5), 453–466.
- Glover, F., 1975. Improved linear integer programming formulations of nonlinear integer problems. *Manag. Sci.* 22 (4), 455–460.
- Gueddar, T., Dua, V., 2012. Approximate multi-parametric programming based B&B algorithm for MINLPs. *Comput. Chem. Eng.* 42, 288–297.
- Gupta, A., Bhartiya, S., Nataraj, P.S.V., 2011. A novel approach to multiparametric quadratic programming. *Automatica* 47 (9), 2112–2117.
- Hladik, M., 2010. Multiparametric linear programming: support set and optimal partition invariance. *Eur. J. Oper. Res.* 202 (1), 25–31.
- Jenkins, L., 1990. Parametric methods in integer linear programming. *Ann. Oper. Res.* 27 (1), 77–96.
- Jia, Z., Ierapetritou, M.G., 2006. Uncertainty analysis on the righthand side for MILP problems. *AIChE J.* 52 (7), 2486–2495.
- Jirstrand, M., 1995. Cylindrical algebraic decomposition—An introduction. Technical Report. Linköping University.

- Jones, C.N., Morrari, M., 2006. Multiparametric linear complementarity problems. In: 45th IEEE Conference on Decision and Control, 2006. IEEE, pp. 5687–5692.
- Khalilpour, R., Karimi, I.A., 2014. Parametric optimization with uncertainty on the left hand side of linear programs. *Comput. Chem. Eng.* 60, 31–40.
- Li, Z., Ierapetritou, M.G., 2007a. A new methodology for the general multiparametric mixed-integer linear programming (MILP) problems. *Ind. Eng. Chem. Res.* 46 (15), 5141–5151.
- Li, Z., Ierapetritou, M.G., 2007b. Process scheduling under uncertainty using multiparametric programming. *AIChE J.* 53 (12), 3183–3203.
- Oberdieck, R., Pistikopoulos, E.N., 2015. Explicit hybrid model-predictive control: the exact solution. *Automatica* 58, 152–159.
- Oberdieck, R., Wittmann-Hohlbein, M., Pistikopoulos, E.N., 2014. A branch and bound method for the solution of multiparametric mixed integer linear programming problems. *J. Global Optim.* 59 (2–3), 527–543.
- Pertsinidis, A., Grossmann, I.E., McRae, G.J., 1998. Parametric optimization of MILP programs and a framework for the parametric optimization of MINLPs. *Comput. Chem. Eng.* 22, 205–212.
- Pistikopoulos, E.N., Dominguez, L., Panos, C., Kouramas, K., Chinchuluun, A., 2012. Theoretical and algorithmic advances in multi-parametric programming and control. *Comput. Manag. Sci.* 9 (2), 183–203.
- Pistikopoulos, E.N., Dua, V., 1998. Planning under uncertainty: a parametric optimization approach. In: Proceedings of the Third International Conference on Foundations of Computer-Aided Process Operations. AIChE.
- Pistikopoulos, E.N., Georgiadis, M.C., Dua, V., 2007. *Multi-Parametric Programming*. Wiley-VCH.
- Ryu, J.-h., Dua, V., Pistikopoulos, E.N., 2007. Proactive scheduling under uncertainty: a parametric optimization approach. *Ind. Eng. Chem. Res.* 46 (24), 8044–8049.
- Saaty, T., Gass, S., 1954. Parametric objective function (part 1). *Oper. Res.* 2 (3), 316–319.
- Sahinidis, N.V., 2004. Optimization under uncertainty: state-of-the-art and opportunities. *Comput. Chem. Eng.* 28 (6), 971–983.
- Schechter, M., 1987. Polyhedral functions and multiparametric linear programming. *J. Optim. Theory Appl.* 53 (2), 269–280.
- Spjøtvold, J., Kerrigan, E.C., Jones, C.N., Tøndel, P., Johansen, T.A., 2006. On the facet-to-facet property of solutions to convex parametric quadratic programs. *Automatica* 42 (12), 2209–2214.
- Strzeboński, A., 2000. Solving systems of strict polynomial inequalities. *J. Symb. Comput.* 29 (3), 471–480.
- Tøndel, P., Johansen, T.A., Bemporad, A., 2003. An algorithm for multi-parametric quadratic programming and explicit MPC solutions. *Automatica* 39 (3), 489–497.
- Wittmann-Hohlbein, M., Pistikopoulos, E.N., 2012. On the global solution of multiparametric mixed integer linear programming problems. *J. Global Optim.* 57 (1), 51–73.
- Wittmann-Hohlbein, M., Pistikopoulos, E.N., 2012. A two-stage method for the approximate solution of general multiparametric mixed-integer linear programming problems. *Ind. Eng. Chem. Res.* 51 (23), 8095–8107.
- Yuf, P.L., Zeleny, M., 1976. Linear multiparametric programming by multicriteria simplex method. *Manag. Sci.* 23 (2), 159–170.