

A MODEL OF LEARNING:  
AN INVESTIGATION OF TECHNICIANS'  
APPROACHES TO OPEN LEARNING

Alison B Strang  
University of London  
Institute of Education

Thesis submitted for the degree  
of Doctor of Philosophy  
November 1989



## ABSTRACT

The work arose from an applied research project commissioned by the Manpower Services Commission. The aim of the project was to produce guidelines for effective learning in the Open Tech, based on a thoroughly researched understanding of open learning at technician level. A review of the literature led to the proposal that the research should examine technicians' experiences of learning from a phenomenological perspective, with particular attention to the intentions and meanings underlying their approaches. In response to this proposal, a metatheory was formulated to establish the assumptions on which the research should be based. The metatheory incorporated a view of man as a natural learner, implying that the research should seek to understand why natural learning behaviour is inhibited. The view of science specified that the outcome of the research should be the development of an appropriate and useful model of technician open learning.

The development of this model was 'grounded' in the empirical study of British Telecom open learning students. The study incorporated both an experimental learning task and focused interviewing. Notable dimensions emerging from learners' accounts of their experiences of learning included: orientations to study, conceptions of learning, and locus of control in learning. Relationships between these dimensions were explored and a series of 'procedural steps' was proposed, which outlines the key processes necessary to effective learning in this context. This empirical analysis led to the formulation of the 'multi-dimensional' model of learning, which suggests that meaningful learning arises as a learner interacts with a task in pursuit of his own learning intentions. On the basis of this definition it was possible to identify the qualities of meaningful learning, and to recognise the equivalence of the notions of meaningful, effective and autonomous learning. The model was tested and elaborated, using data from a further study of a different group of technicians undertaking open learning courses. Finally, the practical applications of the model for the Open Tech were explored.

## ACKNOWLEDGEMENTS

I would like to thank my supervisor Dr Fitz J Taylor for his invaluable support. His skills in stimulating new thinking have enabled me to grow as a researcher, and his advice and encouragement have underpinned the production of this thesis throughout its progress.

An important contribution has also been made by fellow students, in comradeship and the exchange of ideas; by Eileen Sagar, in her extensive practical help with the research; and finally by my husband David, in his enduring patience and understanding.

I am greatly indebted to them all.

## TABLE OF CONTENTS

	<i>PAGE NO.</i>
ABSTRACT .....	2
ACKNOWLEDGEMENTS.....	3
TABLE OF CONTENTS.....	4
LIST OF TABLES.....	8
LIST OF FIGURES.....	11
 <b>CHAPTERS</b>	
 <b>Section 1</b>	
1. The Emerging of our Research Questions.....	12
Open Learning and the Open Tech Programme.....	13
Problems associated with the population of potential Open Tech students.....	18
A consideration of the feasibility of using a 'learning-to-learn' bridging programme in the Open Tech.....	26
Finalising the aims of the research project.....	31

	<i>PAGE NO.</i>
<b>2. Literature Review.....</b>	<b>33</b>
Qualitative descriptions of learning outcome and process.....	39
The factors underlying differences in approach to learning.....	46
Summary and conclusions.....	61
<b>3. A Metatheory of Research into Learning.....</b>	<b>65</b>
Fundamental phenomenology.....	66
Phenomenology in psychology.....	67
The nature of man.....	70
The nature of science.....	75
The nature of our inquiry.....	83
 <b>Section 2</b>	
<b>4. Applying the metatheory to technician open learners:</b>	
Design of study 1.....	86
Aims of the study.....	86
Selection of subjects.....	88
Design of the learning task.....	90
Design of the interviews.....	94
Procedure.....	98
<b>5. Analysis and Presentation of Results: Study 1.....</b>	<b>100</b>
Analysis of learning outcome.....	100
Analysis of approaches to learning.....	107
Questions of theoretical interest	
1. What reasons does X give for studying?.....	111

2. How does X define learning in the context of the experimental learning task?.....	122
3. On what does X focus his attention when studying the learning task?.....	129
4. What are X's general conceptions of learning?.....	135
5. Does X vary his approach in different learning situations?.....	147
6. To what extent does X feel in control of his own learning?.....	157
Questions of practical interest.....	159
<b>6. Discussion: Study 1.....</b>	<b>167</b>
Describing the content of learning.....	168
A consideration of the ways in which this population of learners conceptualise learning.....	172
Towards an understanding of effective learning.....	183
What factors inhibit learners from displaying effective learning behaviour?.....	191
Procedural steps to effective learning.....	196
<b>Section 3</b>	
<b>7. Introducing a Model of Meaningful Learning.....</b>	<b>198</b>
The uni-dimensional formulation.....	199
Introducing an alternative formulation.....	200
Discussion in the light of later work.....	203
Summary of the key differences between the two formulations.....	209

	<i>PAGE NO.</i>
<b>8. Elaborating the Model.....</b>	211
What is meaningful learning?.....	211
When does meaningful learning occur?.....	213
An exploration of the relationship between the multi-dimensional model and the procedural steps.....	218
<b>9. Applying the Multi-Dimensional Model: Study 2.....</b>	221
Design of the Open Tech study.....	222
Manifestations of the characteristics of meaningful learning in learners' accounts of their learning experiences.....	223
An exploration of the conditions under which meaningful learning occurs.....	236
Developing an appropriate model.....	249
 <b>Section 4</b>	
<b>10. Conclusion.....</b>	251
A new metatheory.....	252
The 'Procedural Steps': An explanation of learners' accounts of their learning experiences.....	253
The Multi-dimensional model of effective learning....	255
Identifying the psychological barriers to effective technician open learning.....	256
Learner autonomy in the Open Tech.....	262
 REFERENCES.....	 265
 APPENDICES.....	 276

**LIST OF TABLES**

	<i>PAGE NO.</i>
2.1 The relationship between level of processing and level of outcome.....	38
2.2 Biggs' SOLO taxonomy (Structure of Observed Learning Outcome).....	41
2.3 Levels of abstraction in Biggs' SOLO taxonomy.....	42
2.4 Dimensions of approach to learning.....	57
2.5 Clusters emerging from the study strategy scales of the Lancaster Inventory.....	63
5.1 Quality of learning outcome: Measure A.....	103
5.2 Quality of learning outcome: Measure B.....	104
5.3 Quality of learning outcome: Measure C.....	105
5.4 Quantitative measure of learning outcome.....	107
5.5 Definition of Taylor's orientation categories.....	117
5.6 Examples from this data set illustrating Taylor's categories.....	118



5.7	Learners' orientations to study.....	120
5.8	Primary and secondary orientation types.....	121
5.9	Definition of 'learn' in the context of the learning task (by subject).....	124
5.10	Definition of 'learn' in the context of the learning task (by frequency of occurrence).....	125
5.11	Learners' attempts to define the word 'learn' in the context of the experimental learning task..	126
5.12	Learners' focus of attention in tackling the learning task.....	133
5.13	Equivalence of learners' focus of attention in tackling the learning task.....	133
5.14	Saljo's hierarchy of conceptions of learning.....	144
5.15	Range of conceptions of learning indicated by each learner.....	146
6.1	Focus of attention in task x Quality of learning outcome, measure A.....	169
6.2	Focus of attention in task x Quality of learning outcome, measure B.....	169
6.3	Focus of attention in task x Quality of learning outcome, measure C.....	170

6.4	Focus of attention in task x Quantity of learning outcome.....	170
6.5	The SOLO Taxonomy related to the 'Memorising' to 'Understanding' spectrum.....	175
6.6	The relationship between Vocational-extrinsic orientations and 'Personal' versus 'Ritualistic' conceptions of learning.....	180
6.7	The relationship between Vocational-intrinsic orientations plus Personal-intrinsic orientations, and 'Personal' versus 'Ritualistic' conceptions of learning.....	182
6.8	Relationship between number of conceptions of learning held by each learner and their quality of learning outcome.....	186
6.9	Relationship between number of sophisticated conceptions of learning held by each learner and their quality of learning outcome.....	188
7.1	Sub-categories of the deep approach.....	205

LIST OF FIGURES

	<i>PAGE NO.</i>
2.1 Utilising x Conditions on SOLO level.....	49
2.2 Utilising x Conditions on factual recall.....	50
6.1 Procedural steps to effective learning in this population of technician learners.....	197
7.1 The Deep/Surface dichotomy as a single dimension.	200
7.2 The multi-dimensional model.....	202

## CHAPTER 1

### THE EMERGING OF OUR RESEARCH QUESTIONS

This research is rooted in the attempts of the Manpower Services Commission (MSC) to tackle the problems of adult retraining in Britain. The practical context of the work has had an important influence on both the direction and focus which the research has taken and also on the detailed design and timing of the studies. This chapter sets out to explain the practical problems which have prompted the research, and to describe the context in which it has been undertaken.

In the early 1980's there was great concern about the combined effects of the increasingly hostile economic climate and the rapid development of sophisticated technology in industry. The economic squeeze meant that companies were cutting back on manpower considerably. The impact of this was compounded by technical advances requiring fewer people and new skills.

In response to these concerns the MSC set up a 'Task Group' to explore the feasibility of using 'open learning' methods in adult retraining. They focused on;

"... the crucial importance of properly qualified and up-dated technical support staff to the development of many industries."

(MSC, 1981)

They recognised that if industry was to survive the changes, there was a need for much greater flexibility within the workforce to respond to technical advances. A life-time career could no longer be guaranteed and most people would need to learn new skills and adapt to new roles a number of times during their working life.

Obviously this has important implications for the demand for training and it is the concern of the MSC to promote effective training in this country. The task group felt that the problem was not lack of training resources per se, but rather that existing training resources were being under used. They argued that attention should be directed to exploring

"... means of exploiting more fully both the vocational training resources of this country and also the application of new technologies and modern approaches to training, by what may loosely be described as 'open learning' opportunities."

(MSC, 1981)

### **Open Learning and the Open Tech Programme**

The task group's proposal that an Open Tech programme be set up was accepted, and Dr George Tolley the first Director of the Open Tech detailed its aims as

"...to open and widen access to existing education and training provision..."

"...to make possible new education and training provision for needs which can best be met through open learning."

(Tolley, 1983)

At the heart of this new initiative lies the concept of 'open learning'. What exactly is meant by this label? It is defined at a very general level in the task group's Consultative Document.

"Open learning embraces a wide range of approaches which have a common aim: that of freeing courses of study and training from the constraints that prevent their effective availability."

(MSC,1981)

The central theme of open learning is the idea of 'freedom from constraints' sometimes referred to as 'the removal of barriers to learning'. For example, John Coffey describes an open learning system as:

"... one in which the restrictions placed on students are under constant review and removed wherever possible."

(Coffey, 1977)

Within these definitions the key words 'constraints', 'barriers' and 'restrictions' are open to wide-ranging interpretation. Thus the concept of open learning itself can be interpreted at different levels.

The Open Tech programme has tended to interpret the notion of 'constraints' at a fairly concrete level. An often quoted phrase describes open learning as:

"... arrangements to enable people to learn at the *time, place and pace* which satisfies their circumstances and requirements."

(MSC,1984)

Thus the focus of attention has tended to be on the physical barriers of access and design.

- *Constraints of Place*

Many potential learners are prevented from learning because they cannot attend the particular location where a course is being held, for example where there is only one centre of excellence in the country. Much open learning has therefore taken the form of distance learning. A student is generally following instructional text at a distance from his tutor. Sometimes such courses will be very similar to a conventional correspondence course, sometimes they experiment with new forms of instructional material and types of tutorial and peer support.

- *Constraints of Time*

Obviously distance learning as described above also frees the learner from time constraints because he is free to pursue his study *when* as well as *where* he wants. 'Flexistudy' schemes are a form of open learning addressed to the problem of time constraints. Here a student will attend a particular location, perhaps a college, to make use of the resources available at a time that is convenient to him. Sometimes 'learning-by-appointment' systems are used whereby a student makes appointments to spend time with his tutor. Under the Open Tech programme some large companies have set up 'Learning Centres' which function in a similar way to Flexistudy schemes. These tend to use high technology instructional media such as computer programmes and interactive video as well as text-based materials.

- *Constraints of Pace*

It is primarily due to administrative requirements that most courses impose a specific pace of learning on their students with fixed enrolment and examination dates. Yet some learners, particularly older learners, are simply slower even though capable of achieving the same goal as a faster learner. These constraints of pace seem to be particularly difficult to overcome especially when national examinations or assessments are

involved. Where possible a 'roll-on/roll-off' enrolment strategy is adopted, and where there is no formal assessment involved students can be free to pick up and put down their learning at their own convenience.

In the Open Tech programme open learning has been characterised by the individual learner working on his own with some form of instructional material. The amount of contact with a tutor and the degree of structure varies widely and there is encouragement to experiment with new approaches. See *The Open Tech - Programme Development Review, Final Report* (Tavistock Institute of Human Relations, 1987) for descriptions of the range of Open Tech projects.)

However, open learning can also be understood in much broader terms. Roger Lewis captures this breadth in his definition of open learning.

"'Open learning' is a term used to describe courses flexibly designed to meet individual requirements. It is often applied to provision which tries to remove barriers that prevent attendance at traditional courses, but *it also suggests a learner-centred philosophy.*"

(Lewis & Spencer, 1986 - my italics)

Also, Doug Spencer writing elsewhere argues that although open learning embraces a wide variety of approaches, the common feature is, "... a degree of student autonomy." (Spencer, 1980)

The restrictions of 'time, place and pace' are certainly sometimes very effective barriers to learning, but there can also be many hidden psychological barriers which seriously interfere with successful learning. If learning opportunities are to be fully 'open' then even these hidden barriers must be identified and addressed. Providing learning opportunities which are learner-centred in this sense would lead to radical changes. It involves encouraging learner autonomy and requires that learner needs, rather than organisational needs, are at the centre of decision-making. Open learning in *this* sense challenges the assumptions and priorities of much existing educational and training provision.



Yet it is apparent in the original Open Tech Consultative Document that it was intended that the Open Tech should indeed embrace this broader understanding of open learning. The task group outlined the features distinguishing an 'open' approach:

"...(open learning) is *centred on the needs and circumstances of the students and trainees* rather than those of educational or training institutions and their administrative systems."

"...is *problem-centred*: its aim is to identify the particular barriers to access and learning which are present in any one case and then incorporate whatever...will best overcome these barriers."

"...(is) not only concerned with structures and arrangements but also with *how people learn*..."  
(MSC, 1981)

The Open Tech programme was launched in 1983. It did not involve the setting up of a new training institution equivalent to the *Open University*. Instead a unit - the *Open Tech Unit* (OTU) - was established within the MSC with responsibility to promote the development and use of open learning for adult training. It had control of a large budget which was to be used to help other organisations to develop open learning approaches to training. Organisations such as FE Colleges, Employers Associations, Industrial Training Boards and large companies became involved in the pioneering work. The OTU had the responsibility of supporting these initiatives, providing advice and expertise and monitoring the quality of programmes being developed.

The origins of the present research project

We have seen that open learning is concerned with the needs of individuals, and in particular with how those individuals learn. Even at the early stages of the task group Consultative Document (MSC, *ibid.*), a consideration of the characteristics of the potential student population

led to the belief that many of them were likely to experience problems in learning. It was suggested that

"... a variety of 'bridging' or 'learning-to-study' programmes may be necessary to enable them to exploit their potential to train at technician levels."

(MSC, 1981)

At about this time, the Industrial Training Research Unit (ITRU) in Cambridge was developing a 'learning-to-learn' programme (Belbin, Downs, and Perry, 1981). The programme aimed to help "... young people to acquire a generalised strategy for learning after they have left school." (Downs and Perry, 1982). It appeared that adaptations of such a programme might make a valuable contribution to the Open Tech, so the ITRU was asked to explore the feasibility of this idea.

#### **Problems associated with the population of potential Open Tech students**

In effect the resulting research project was given the responsibility of identifying some of the hidden psychological barriers which learners experience preventing them from, "... exploiting their potential to train at technician level." (MSC, 1981). However with the suggestion of developing a 'learning to study' programme, the assumption had been made that the main barrier would be a lack of skill in studying. This assumption might well be correct, but it was felt important that no assumptions should be accepted unchallenged because any such programme must be developed on a thoroughly researched basis.

Therefore the first step was to become familiar with the context of the Open Tech, the characteristics of the potential student population, and the implications of these for learning. There follows a brief discussion of these issues which should serve to explain the early development of

the research and the context within which the entire study has been pursued.

#### Problems associated with adult training

The Open Tech is concerned with adult training, and it was anticipated that most students would be over 25 years old. This immediately identifies them as a group potentially with special needs. In their book, *Problems in Adult Retraining* (1972), Eunice and Meredith Belbin have suggested that high levels of anxiety often seriously inhibit adult learners. They report that this problem has been identified physiologically by the measurement of levels of free fatty acid content in the blood (a sensitive indicator of stress). It has been shown that during training sessions, levels rise more in older learners than younger learners. A link has also been demonstrated between a rise in free fatty acid levels and poor learning performance.

Anxiety is another way of referring to level of arousal, and some degree of arousal is necessary to elicit attention and concentration for learning. However too much arousal which would be classified as *anxiety* impairs concentration because it distracts ('Yerkes-Dodson Law', 1908). Anxiety also discourages the learner from taking risks.

It seems likely that part of the reason why adult learners are more anxious than younger learners is that they have more at stake when they undertake learning. They are putting themselves in a subordinate position and risking the possibility that they might fail to achieve the learning goal and thus fail to return to equilibrium again. Learning anything involves change of some kind and that change will generally be seen as an improvement. This implies that what went before was wrong or inadequate in some way. The acknowledgement of personal inadequacy is much more painful for an adult than a child because the adult has invested so much more in his or her 'previous self'.

Feeling threatened by learning leads to a heightened concern for accuracy. The individual is anxious not to fail and therefore will be hesitant to try anything until he is confident that he will get it right. The Belbins (ibid.) found that adults were generally much more concerned with accuracy than speed when training. Sometimes such hesitancy can be an advantage. This is particularly true of learning motor skills where adults appear to be slow to correct mistakes once they have become established. Therefore it is important for adults to have their errors corrected immediately. This could constitute a very serious difficulty for those attempting to learn motor skills at a distance. Yet in all learning it is essential to take *some* risks - it is only as the learner tests out his learning that he can gain feedback as to its success.

Adult learners seem to be hampered by a shared belief that their learning capacities diminish as they get older. There is some truth in this. For example, the short-term memory is less efficient with age thus hindering rote learning (Welford; 1962). Also it is more difficult for older people to learn skills involving manual dexterity simply because the body is not so supple. However, as Lalage Bown points out (Bown, 1986), on the whole the greatest academic achievements are not attained by teenagers, but by people of middle age and beyond. This is partly because the slight disadvantages brought about by physical deterioration are over-compensated for by the advantages of experience. Experience gives the adult a rich and meaningful framework against which to assess and evaluate new information. This is perhaps why adults are more intolerant than younger learners if learning tasks seem meaningless or irrelevant. It is important to an adult that he understands the point of an exercise. Where learning is perceived as relevant then adults are able to draw upon their rich resource of experiences (Knowles, 1986).

Age and experience however can also bring rigidity. Jennifer Rogers (Rogers, 1971) particularly comments on adults' unwillingness to try new teaching methods. She argues that this can apply both to those who have happy experiences of past learning, and to those who have negative experiences of previous learning. Those with happy experiences do not want to risk doing things differently. Those with negative experiences

would still prefer to stay with 'the evil they know'. This phenomenon could pose problems when introducing the many new and imaginative training methods developed in open learning.

In many ways open learning is more appropriate for the adult learner than traditional methods. For example the Belbins (1972) advocate that adults be allowed to learn at their own pace. They also argue that adults are more successful with longer training sessions than young people whose attention span is limited. Both of these constraints cause problems in a conventional setting and yet are overcome very simply within open learning.

Open learning is an individualised approach and can be very private. This alleviates the stresses that a threat to status can cause the adult. For example, most managers are unwilling to go on a training course which would put them in a classroom with very junior employees. Yet a complete spectrum of the workforce could all follow the same open learning course without being embarrassed in this way.

#### Problems associated with technician training

Another key defining characteristic of the population of Open Tech learners is that they will be technicians. George Tolley outlined the target area as follows:

"The Programme is concerned with technician  
and supervisory levels of skill and knowledge."  
(Tolley, 1983)

However, defining the meaning of the word 'technician' is not so simple because it is used in vastly different ways in different industries. The OTU has adopted the definition developed by the Technician Education Council:

"... a broad band of personnel who have certain  
features in common: they have to exercise

technical judgement, understand the principles underlying their work and the purpose of what they are doing, and often supervise other staff."

(TEC, 1980)

As the description indicates, it can be a very demanding role involving the exercising of a wide variety of skills.

The experience of the researcher in technician training suggested that on the whole, technicians tend to be practical rather than theoretical. People in technician level jobs are likely to have demonstrated average academic ability at school (entry requirements generally demand qualifications indicating average academic ability). So it is likely that any group of technicians will include some who have a negative attitude to school-type learning. Many will simply be out of practice in studying.

A significant cause of problems could be insecurity for many learners. The Open Tech aims to keep the workforce up-to-date with technology and to teach new skills where old ones have become redundant. Therefore some technicians who had expected their apprenticeship to equip them for life will find that their hard-won skills now count for very little. With morale consequently at a low ebb they will then have to tackle an Open Tech course. Others may even be threatened by redundancy and be forced to undertake retraining to have any hope of securing employment in the future. Such a climate of fear and insecurity will compound the problems of anxiety which adult learners experience.

Problems associated with volunteers and 'conscripts' for learning

This brings us to the third important aspect of the Open Tech programme which alerts us to potential learner problems. The Consultative Document (MSC, 1981) suggests that the range of potential learners will include:

- those undertaking training at the request of, and provided by their employer.
- employed people undertaking training on their own initiative to enhance their skills.
- unemployed people hoping to use training as a step towards securing employment.

For those who are volunteers there will be the usual problem experienced by adult educators that the learners tend to 'vote with their feet'. Anita Shanley, referring to adult education classes, complains that

"... they will disappear at the slightest feeling on their part that for one reason or another it is just too much bother to make the journey."

(Shanley, 1986)

Perhaps to infer that even the 'slightest reason' will deter a volunteer learner is a little unfair. However Shanley's comment does remind us that for a volunteer learner, studying is only one of many demands competing for his time and attention. Therefore it is not only important that a course *is* relevant and useful to the individual, but also that he *perceives* it as relevant and useful so that motivation is maintained throughout.

Motivation can also be a problem where attendance is not voluntary. Lalage Bown addresses this problem.

"Where attendance is *not* voluntary, as for instance in training programmes organised by the Manpower Services Commission, there is not

the same need to ask what *attracts* people to learning opportunities, but there is still a need to ask how they can be helped to make the most of courses provided at considerable public expense - *for attendance itself doesn't guarantee learning.*"

(Bown, 1986 - original italics)

This is very pertinent to the concern of this research which is to enable people to become effective, independent learners and not simply to ensure that they participate in Open Tech courses.

The implications for using open learning in this context

Our consideration of the characteristics of the potential Open Tech student population has identified two main potential sources of problems: one is anxiety, and the other motivation.

- Anxiety

In a conventional training or educational setting anxiety is eased through the social contact of the learning group and the direct support and encouragement of the tutor. In open learning, contact with other learners and tutors is often minimised, and the learner is working alone for much of the time, so this support will be lacking.

However some of the causes of anxiety are alleviated by this same characteristic of 'open' approaches. Where there is very little contact with peers there will be little opportunity for competition between learners. Thus the threat of exposure of inadequacy is much reduced. The learner can make his mistakes in private - sometimes even without his tutor knowing. He can take time over difficult sections without worrying about falling behind others. Privacy can help considerably when learning content is very personal and affects attitudes deeply. Wendy Stainton Rogers provides a powerful illustration with her account of the dramatic



effect that an audio tape about senile dementia had on a student in charge of an old people's home causing her to completely change the policy of the home with regard to family involvement (Stainton Rogers, 1986).

True open learning where learners are expected to take responsibility for their own progress is very demanding. This can be stressful simply because it is new and different, particularly when individuals are used to being passive. However in the long run the open learning approach appears to be well suited to adult training needs. We have said that it is important to adults that they appreciate the relevance of learning tasks and learning content. In open learning learners are able to control this for themselves. This suits the adult technician's problem-solving orientation. Also in open learning there is scope for the learner to capitalise on his experience because studying can be fully integrated with his life.

#### - Motivation

It appears that for many reasons adulthood can be a very fruitful time for studying. Lalage Bown lays down three conditions for continued effective learning throughout life.

- good physical health.
- the sustained act of continued learning itself.
- strong motivation.

(Bown, 1986)

She would agree that of these three, motivation is the key. With strong motivation the activity of learning will be sustained and many minor physical disabilities can be overcome. Motivation is particularly important in open learning because the more autonomy that is given to the learner the more responsibility the learner has in pursuing his learning.

However as we have acknowledged, motivation might well be a problem for some Open Tech students because of the employment conditions which have prompted their learning and because of the isolated nature of some open learning courses.

**A consideration of the feasibility of using a 'learning-to-learn' bridging programme in the Open Tech**

These preliminary analyses supported the assumption that open learning is an appropriate approach to adult technician level training. Yet they also confirmed that many students would be likely to experience difficulties in learning effectively and making the most of open learning opportunities. Such difficulties constitute, "... constraints that prevent (the) effective availability" (MSC, 1981) of opportunities for study in just the same way as inconvenient locations or rigid enrolment dates. Therefore the Open Tech must be concerned to remove such barriers. The suggested solution was to design a learning-to-learn bridging programme for Open Tech courses. The aims of such a programme would be:

- a. To help students to learn effectively.
- b. To help students to become self-directing and independent learners.

Therefore the next task in the current project was to examine the assumption that such a programme would be the most effective approach.

## A review of learning-to-learn and study skills training

The history of attempts to help students learn more effectively goes back a long way. For instance Mann quotes Plato as arguing that,

"Arithmetic stirs up him who is by nature  
sleepy and dull, and makes him quick to learn,  
retentive and shrewd."  
(Mann, 1979)

More recently, throughout this country, there has been a plethora of books, television programmes and courses attempting to teach study skills as the tools of the trade. As an example to illustrate this, the books and programmes of Tony Buzan have had a strong following in recent years. His book *Use Your Head* (1974) includes chapters on, 'Reading more efficiently and faster', 'Memory' and 'Noting'. He teaches imaginative and sometimes sophisticated techniques and strategies. The experience of the ITRU suggests that some learners find these methods tremendously helpful, but others appear to remain untouched. Why is this?

### Problems of transfer and the nature of change

One of the problems, as Hills and Potter (1979) argue, is that the student needs to have a fairly high level of skill already in order to learn from a book or course. He has to be able to extricate the relevant information and apply it to new situations. Students may well acquire knowledge and skills for studying and even be able to perform tasks using them very successfully. However this is no guarantee that they will subsequently be able to use this knowledge and skill whenever appropriate. Bransford et al (1986) point out that both learned knowledge and skills will remain inert, unless the learner is also taught the conditions under which they are relevant so that he can access these skills.

Another problem for many learners appears to be that they are simply not consciously aware of their learning at any time. Lack of such metacognitive control has been recognised as a cause of learning disability in children and teenagers (eg. Wiens, 1983). Bransford's investigations support this. He found that unlike successful readers, less successful readers can neither anticipate which text they might find difficult nor identify the source of their problems (Bransford, 1981).

Some learning-to-learn courses set out to teach metacognitive control, for instance Dansereau (1979) and Brown, Campione and Day (1981). They teach learners to evaluate their own progress by asking themselves questions and to experiment with different solutions to problems. These approaches appear to achieve some measure of success in improving school learning. However a danger pointed out by Coles and Fleming (1978) is that the learning strategies are presented as a complete package. Such presentation implies that the package must be accepted or rejected in its entirety, and thus no value is placed on the learner's previous experience or existing skills. Under these conditions learners are less likely to adopt these learned approaches and to use them for their own purposes.

Elton (1979) reports the results of his trials of a study skills guide which was designed to contribute to a Keller Plan course in Classical Mechanics. He found that the students who appreciated the study guide already used a similar approach and therefore found it easy to incorporate the advice given. Of those who rejected the guide, most argued strongly in justification of their own existing strategies and techniques as viable alternatives.

Part of the problem is that when it really matters, most people would rather use tried and tested methods to achieve their goals - even if those methods have acknowledged disadvantages. To change to a radically different approach is too risky when there is much at stake. This problem is addressed in the United States of America where much of the learning-to-learn work is based on a counselling model. The emphasis is on trying to create a secure environment for change (eg. Da Costa, 1979; Garfield and McHugh, 1978; Roueche and Snow, 1977), but usually the focus has still

been on teaching a specific set of strategies and techniques. In Britain, Graham Gibbs (1981) has argued that adopting new approaches to learning involves changes in attitude, and that attitudes only change gradually by the testing of new ideas against the old. Therefore he gives learners the opportunity to reflect on their techniques, compare and criticise them, and experiment with new approaches. Thomas and Harri-Augstein (1977) have also developed an approach which starts by looking at what the learner already knows and thinks, using George Kelly's Personal Construct theory.

In the current research the concern is that learners become not only effective but also independent. Therefore it will be important that they are able to use any strategies or techniques for their own purposes, and use them independently without needing prompting.

#### Conceptions of learning

Evidence suggests that the effective use of study skills can be prevented by a further barrier - lack of understanding of the nature of the learning task. As Gibbs (1981) points out, a learner is not helped greatly by his perfectly formed patterned notes if he is not able to identify the appropriate key points to note down. Angela Brew of the Open University finds that year after year, during the Summer Schools, students ask, "How do I know which are the key points?" (Brew and Batten, 1981). She suggests that learners do not perceive the underlying structure which renders the material meaningful, and therefore do not grasp the author's message. With her colleague Mary Ann Batten, Angela Brew designed and ran training sessions which attempted to alert undergraduates to the existence of an underlying structure, and teach them how to distinguish the various aspects of a text. Students found this extremely difficult. For instance, very few of them could differentiate between a principle and an example. This phenomenon has been referred to as 'horizontalisation' (Marton and Saljo, 1979), where all elements of a text are considered to have an equivalent role and any hierarchical structure

is ignored. It is not surprising that learners who view the text in this way have difficulty in picking out the main points.

The ITRU 'Learning-to-learn' programme encountered similar problems. The programme involves teaching learners to distinguish between learning tasks which require 'Memorising', 'Understanding' and 'Doing'. Learners could identify 'Doing' tasks quite easily, but had great difficulty in distinguishing between 'Memorising' and 'Understanding' tasks (Belbin, Downs and Perry, 1981). This is consistent with the phenomenon of horizontalisation. Moreover, Belbin et al report that learner problems were on occasion compounded by teachers who could not grasp the distinction either.

It appears that less successful learners are not necessarily simply lacking the skill in technique. We must recognise that the nature of learning itself is ambiguous and not understood alike by all. This is true both at the micro level - the understanding of a particular learning task - and also at the macro level - the understanding of the nature of studying. In addition, it is true both of learners, and also of teachers. Coles and Fleming (1978) recount their experiences of running an induction course jointly with the staff of a university engineering faculty. Staff reaction to the course divided into two clear groups. Some staff saw their role as teachers as imparting all their knowledge to passive recipient students. They felt that the learning-to-learn course was at best not particularly important, and at worst totally irrelevant. In contrast the other group saw engineering as a 'method of inquiry' or 'the solving of human problems'. They welcomed the learning-to-learn course, feeling that students need to take responsibility for their own learning and are often ill-equipped to do so. Their understanding of what learning is all about was crucial to their appreciation of the value of the course, and so probably crucial to their effective use of it.

The ITRU's experience with different groups of learners could be understood in a similar way (unpublished internal reports). They tended to find that the course was more successful with students following Arts or Social Science courses. Those studying technical subjects were more

resistant to the course in the first place, and slower to accept its value. Perhaps this reflects an underlying difference in attitudes to learning within the disciplines.

Angela Brew (1981) appears to be describing the same problem:

"... students often come to a study methods course in the expectation that they will be told how to write better essays, read faster, make better notes etc. This is consistent with the view that there exists a definable set of study 'skills' which can be learnt or acquired. Teaching students that there are no simple solutions and providing them instead with activities designed to stimulate in the student a re-examination and re-negotiation of his conceptions is itself contrary to some students views of learning and of the knowledge presented in courses."

(Brew, 1981)

It is clear that the process of 'learning-to-learn' involves fundamental changes. It does not only involve the acquisition of skills, but also growth in the understanding of the nature of learning tasks, and changes in attitude to the phenomenon of learning.

#### **Finalising the aims of the research project**

If the aim of the Open Tech programme was to remove barriers to training, then the concern of the ITRU project was to tackle the hidden psychological barriers existing within learners themselves. The original research proposal was to adapt a 'Learning-to-learn' programme, already developed by the ITRU, for use in the Open Tech. However a consideration of the likely problems experienced by Open Tech learners, and then a review of the learning-to-learn, or study skills approach, suggests that

simply teaching the learners study skills would not be effective. It appears that the barriers likely to inhibit the effectiveness of technicians' learning are more fundamental. Preliminary analyses have highlighted problems such as anxiety and motivation. These represent underlying psychological barriers which need to be tackled in order to help technician open learners to learn more effectively.

In negotiation with the Open Tech Unit, it was agreed that a full investigation was merited to identify the barriers to effectiveness experienced by technician level open learners. Guidelines for the design of open learning for technicians could then be drawn up based on the research findings. The research project therefore set out to try to identify the psychological phenomena which act to inhibit the effectiveness of technician open learners. Inevitably, on occasion, design and progress have been constrained by the pragmatic concerns of the sponsor, however a striving for academic rigour has remained a high priority throughout. The coexistence of these academic concerns and day to day contact with training practitioners has enriched the research process. This thesis reports the progress of that research (chapters 2 to 6), and considers some of the theoretical (chapters 7 to 9) and practical (chapter 10) implications.



## CHAPTER 2

### LITERATURE REVIEW

Many of the attempts to improve learning through study skills training discussed in the last chapter stem from research in the cognitive tradition. A number of psychologists concerned with the field of education have become disillusioned with the contribution made to educational practice by this traditional approach. Noel Entwistle, after reviewing the outcomes of mainstream research on learning, concludes that

"This body of research on motivation and study methods has made relatively little impact on higher education. It has provided a rationale for providing advice for students on effective study skills, but the plethora of handbooks on the subject has had little if any effect."

(Entwistle, 1984, p12)

In recent years a new approach to the study of learning has been gathering momentum. The movement has been led by a group of researchers at Gothenburg University in Sweden. They observe that traditional quantitative methods, "... fail to establish *functional* relationships between study activities and learning outcomes." (Svensson, 1977, p233). They have therefore rejected the traditional perspective which can be described as noumenal, in favour of a phenomenological perspective in conducting learning research. Marton and Svensson clarify the difference in perspective which characterises the work of the Gothenburg group:

"The traditional perspective in research into student learning focuses attention on the learner in an attempt to find out or to test hypotheses about how he can be characterised,

what he does and how he functions. The learner is the object of our study and we (the researchers) observe him and his behaviour or functioning....

...There is, however, an alternative perspective we can take: the learner's own. In this perspective the world as experienced by him becomes visible. His experience of the world is a relation between him and his world. Instead of two independent descriptions (of the student on the one hand and of his world on the other) and an assumed relationship between the two, we have one description which is of a relational character."

(Marton & Svensson, 1979)

Essentially it can be seen that traditionally the researcher has attempted to observe and measure learner behaviour from without and to draw conclusions about effective learning from such observations. In taking a phenomenological approach, the researcher "... seeks an empathetic understanding of what is involved in student learning derived from students' descriptions of what learning means to them." (Entwistle, *ibid.*, p13). It is hoped that such specific understandings will illuminate educational practice.

The work of the Gothenburg group itself has been very influential in the last decade, leading to a large number of studies using similar methodology to explore students' experiences of learning. Prior to this, phenomenological studies have been fairly rare. Yet the work of a number of very influential researchers has fallen within this alternative approach (eg. Becker, 1968; Perry, 1970; Miller and Parlett, 1974). Entwistle, in his introductory chapter, *Contrasting perspectives on learning* (1984), provides an excellent account of such work and its contribution to both the theory and practice of phenomenological research into educational topics. The reader is therefore referred to this paper and the discussion is not repeated here.

The phenomenological approach is of particular significance to the present study because, as Marton and Svensson point out, "In this perspective, the world as experienced by him (the learner) becomes visible" (*ibid.*). The initial consideration of the problem of effective

learning at technician level in the Open Tech suggested that attention be paid to learners' motivation, anxiety, and their awareness and understanding of the learning process itself. These are all qualities of the learner's relationship with the world, and cannot be directly accessed by an external observer. They are more readily and more appropriately studied through the eyes of the learner, in other words, from a phenomenological perspective.

Obviously, an approach which differs so radically from the conventional positivist research tradition raises numerous philosophical and practical questions. These will be discussed in chapter 3. In this chapter recent research on the learner's experience of learning will be reviewed. The work of the Gothenburg group will be used as a framework to explore the issues which have been raised.

Marton and Svensson, already quoted, are leading members of the Gothenburg group; they suggest that the individual's experience of learning comprises his awareness of content, context, and a consciousness of the act of learning itself (ibid.). The early research of the Gothenburg group has concentrated on describing these aspects of learner experience.

Learners' experience of the content of learning.

Dahlgren was one of the early contributors to the work of the Gothenburg group. His research demonstrates the inadequacy of quantitative measures as an indication of learning success. In one study he looked at university students' ideas about everyday concepts in economics (Dahlgren, 1978). He asked 13 students before they started their economics course about - amongst other things - their concept of price. Student responses fell broadly into two categories:

- A. Price is determined by the relationship between supply and demand for commodities.
- B. Price is determined by the value of a commodity or the accumulated value of its constituents.

Six students gave 'A' type answers which accurately reflect the meaning of the term 'price' as used in the academic discipline of economics. Seven students gave 'B' type answers which could be described as the slightly naive common sense idea of 'price'. After completing the course, fifteen out of the total of eighteen students enrolled gained enough marks to pass their exam. Yet when Dahlgren interviewed the original students again, he found that this time only four students gave 'A' type answers.

This finding was generally confirmed across the various economics concepts which Dahlgren studied. Students were able to respond to exam questions in such a way as to satisfy their examiners of successful learning. However when Dahlgren explored their understanding qualitatively in the context of interviews, it was clear that their conceptions were little changed; there was simply a marked increase in the use of economics jargon.

Learners' experiences of the context and process of learning

Marton argues that the process of learning can only be studied in relation to the specific content. He has conducted a series of related studies with different colleagues of the Gothenburg group. The results of these were first reported to a wider audience in *The British Journal of Educational Psychology* in 1976.

Marton outlines his experimental procedure:

"In essence, groups of students were asked to act as paid volunteers. Each student, individually, was asked to read one or more passages of prose within suggested time limits, and was subsequently asked specific questions about the passage and, in some experiments, was

also asked to explain to the experimenter what the passage was about. The conversation, which was recorded, allowed the experimenter subsequently to study the whole pattern of the response, including hesitations and various attempts at recalling different aspects of the passage which had been read. The student was then given a series of open questions to elicit how he had tackled the process of reading, and asked to answer a series of specific questions designed to assess what had been understood."

(Marton and Saljo, 1976a)

Like Dahlgren, Marton and Saljo found that students' learning outcomes could be classified into a number of qualitatively distinct and usually hierarchically related categories.

Marton and Saljo then went on to analyse the data gathered from their introspective questions, in which students described the way they tackled the experimental task. They discovered two distinct *levels of processing* which they suggest "might explain the differences in learning outcome." (Marton and Saljo, *ibid.*, p9). They describe the levels of processing as follows, giving examples:

"In *surface-level processing* the subject focuses on *the sign* (ie, the discourse itself or the recall of it)."

*For example,*

"Well, I just concentrated on trying to remember as much as possible."

"*Deep-level processing* indicated that students had concentrated on *what is signified* (ie., what the discourse is about).

*For example,*

"I tried to look for...you know, the principle ideas..."

(Marton & Saljo, 1976a)

When they compared learners' reports of their approach to learning as analysed above with the qualitative measure of their learning outcome, they found a clear pattern:

**Table 2.1: The relationship between level of processing and level of outcome.**

Level of Outcome	Level of Processing			Sub-totals
	Surface-level	Not clear	Deep-level	
A			5	5
B	1	6	4	11
C	8			8
D	5	1		6
Sub-totals	14	7	9	30

(Marton & Saljo, 1976a)

It appears that students adopting a 'deep-level' approach to their study are more likely to gain a higher quality of understanding (level of outcome category A), and those adopting a 'surface-level' approach more likely to achieve a poorer quality of understanding (level of outcome category D). As Morgan et al. point out "...this is not simply a quantitative difference in a variable such as motivation or attention. It is a *qualitative* difference in level of approach." (Morgan, Taylor and Gibbs 1982). Marton and Saljo's findings seem to suggest that students will learn more effectively if they pay attention to the intentional content of learning materials rather than the surface characteristics.

## Implications of the early findings of the Gothenburg group

Such a conclusion is of great significance to those concerned with effective student learning. The implication is that the key to improving the quality of learning lies in the intention of the learner in tackling a particular learning task. This relates closely to the weakness of many study skills courses discussed in the previous chapter, of ignoring the nature of the learner as an intentional being. It does indeed look as though the approach of the Gothenburg group can open up our understanding of student learning.

However the outcomes discussed so far are based on a few small scale studies all using a very similar methodology. An important aspect of phenomenological research is that findings are seen as illuminative but not necessarily representative of general laws. A considerable amount of research has come out of these studies which throws light on the way these ideas relate to other contexts. This chapter will consider

1. Studies (both within the phenomenological perspective and outside it) which expand the qualitative dimensions of (A) outcome and (B) process in learning.
2. Studies which explore the major factors influencing learners' approaches to learning.

## Qualitative descriptions of learning outcome and process

### (A) Qualitative descriptions of learning outcome

As we have seen, both Dahlgren and Marton observed qualitatively distinct levels of learning outcome in their experiments. Dahlgren distinguishes between conceptions of price as follows,

"The difference between (conceptions) A and B can be described in terms of whether price is conceptualised in system-oriented terms (which is more dynamic and abstract) or whether it is regarded as a property of a commodity (which is both more static and concrete)."

(Dahlgren, 1978)

This distinction is partially based on level of abstraction. Marton is in a different position when categorising quality of understanding in his experiments because he has the immediate standard of the text presented from which to draw comparisons. His distinctions are based on the degree to which the learner has appreciated the intentional content of the text, and range from a complete appreciation of the author's message to answers which are 'content-free' in the sense that they are merely a re-statement of the question.

Although we can abstract criteria of judgement, Marton and Dahlgren are not of course seeking to develop a method for systematically measuring learning quality. However, John Biggs of Australia has developed such a measure, although once again this was not his original intention (Biggs, 1979). Biggs was collecting examples of school pupils' learning outcomes to illustrate Piaget's developmental levels of thinking (Piaget, 1954) for subject teachers. Thus his methodology is compatible with that of the phenomenologists. His system is 'grounded' in Glaser's sense (Glaser and Strauss, 1967) in that it emerges directly from the empirical data, rather than being developed *a priori* from a theoretical base as for example Bloom's taxonomy of educational objectives (Bloom et al., 1956).



*Table 2.2: Biggs' SOLO taxonomy (Structure of Observed Learning Outcomes)*

---

1. *Pre-structural*. The response has no logical relationship to the display being based on inability to comprehend, tautology or idiosyncratic relevance.
  2. *Uni-structural*. The response contains one relevant item from the display, but misses others that might modify or contradict the response. There is a rapid closure that oversimplifies the issue.
  3. *Multi-structural*. The response contains several relevant items, but only those that are consistent with the chosen conclusion are stated. Closure is selective and premature.
  4. *Relational*. Most or all of the relevant data are used, and conflicts resolved by the use of a relating concept that applies to the given context of the display, which leads to a firm conclusion.
  5. *Extended abstract*. The context is seen only as one instance of a general case. Questioning of basic assumptions, counter examples and new data are often given that did not form part of the original display. Consequently a firm closure is often seen to be inappropriate.
- 

(Biggs, 1979)

Clear parallels can be seen here with the approach of the Gothenburg group to classifying quality of learning outcome. SOLO levels 1 to 4 particularly seem to cover the range of Marton's examples of four different levels of outcome (see Marton and Saljo 1976a). However, level 5 introduces a new dimension which Marton does not discuss - that of elaboration of the material presented. Marton's criterion of appreciation of the intentional content does not appear to give scope for this.

Another distinction can be seen between Dahlgren's work and Biggs'. Dahlgren who, like Biggs, is not tied down to specific learning input, distinguishes between the level of abstraction. In the basic SOLO system

presented above there is no opportunity to acknowledge different levels of abstraction apart from the very simple one entailed in the progression from isolated facts (Uni-structural) to recognition of these facts as illustrations of general cases (Relational or Extended abstract). To cover different levels of abstraction Biggs appeals to Piagetian stages and suggests that responses at each Piagetian stage can either be referred to using the SOLO levels 2 to 4, or be seen as levels 5 and 1 of the stage immediately below or above respectively (Biggs,1982).

**Table 2.3: Levels of abstraction in Biggs' SOLO taxonomy**

Intuitive			Uni-structural
			Multi-structural
	Pre-structural	=	Relational
	Uni-structural	=	Extended abstract
Concrete	Multi-structural		
	Relational	=	Pre-structural
	Extended abstract	=	Uni-structural
Formal			Multi-structural
1st Order			Relational

(Extract from, table 10.1 p216, Biggs 1982)

Thus the system becomes much more complex and dependent on Piagetian psychology. Nevertheless the SOLO taxonomy makes an important contribution to the conceptual complexity with which we can consider the quality of learning outcomes.

## (B) Qualitative descriptions of learning process

We now turn to the learner's experience of the process of learning. First we will consider some of the dimensions which have been used to describe students' approaches to learning. We will then go on to explore the factors affecting learning approaches and further refinements of the descriptions of learning process which have been developed.

Svensson provides a confirmation of Marton and Saljo's work by his independent reworking of their original data (Svensson, 1977). As part of a wider project he re-analysed learners' accounts, both of their understanding of the text and of their approaches to studying it. Svensson gave a slightly different emphasis in his analysis being concerned not to violate "...the unity of knowledge and cognitive skill." (Svensson, *ibid.*, p237). Thus he looked at learners' approaches in the light of the nature of their learning outcomes. He described the two distinct approaches which he found as 'atomistic' and 'holistic';

"The *atomistic* approach was indicated when students described their activities as involving: focusing on specific comparisons, focusing on the parts of the text in sequence (rather than on the more important parts), memorising details and direct information indicating a lack of orientation towards the message as a whole. In contrast, the *holistic* approach was characterised by students' attempts: to understand the overall meaning of the passage, to search for the author's intention, to relate the message to a wider context and/or to identify the main parts of the author's argument and supporting facts."  
(Svensson, 1977)

Although these descriptions are subtly different from those of Marton and Saljo, in 25 out of the 30 cases responses originally classified as indicative of deep-level or surface-level processing were classified as holistic or atomistic respectively, thus showing a high level of agreement between the two analyses.

Svensson's descriptions of atomistic and holistic approaches are particularly interesting in the way that they relate to the work of Gordon Pask who has tackled the study of approaches to learning in a very different way. Pask's conceptualisation of learning and his early research methodology seem to have emerged from Bruner's work on concept formation (Bruner Goodnow and Austin, 1956). Pask originally presented learners with the task of finding out about complex conceptual structures by turning over a series of cards with different categories of information on them (Pask and Scott, 1972). He asked his subjects to explain their rationale for looking at each card and thus built up a picture of their strategies in understanding the task. Although this procedure perhaps seems far removed from the approach of the Gothenburg group, Pask's findings provide a parallel to theirs. He reports that two distinct learning strategies were observed: 'Serialists' followed a step-by-step learning procedure concentrating on narrow and simple hypotheses relating to one characteristic at a time; 'Holists' tended to form more complex hypotheses relating to several characteristics, and made wide use of analogies.

This dimension appears to be similar to Marton's deep-level and surface-level processing, with the same contrasting emphasis on either discrete elements or the whole. It is interesting to note that Svensson with his emphasis on looking at both knowledge structure and cognitive skill together has developed a definition which is closer to Pask's than is Marton and Saljo's. However, both Svensson's and Marton's definitions are logically distinct from those of Pask because for Marton surface-level processing (and for Svensson, an atomistic approach) leads only to incomplete, poor quality understanding, whereas in Pask's work, both the holistic and atomistic strategies were observed as alternative routes to complete understanding (this was a constraint on the experimental design).

Pask goes on to claim that the distinction is not just an artefact of the experimental task, but indicates a psychological difference in learning styles (Pask, 1976 ). He argues that if the strict conditions leading to complete understanding of his experiment are removed then holists and

serialists will in turn demonstrate the pathologies of comprehension learning and operation learning. Comprehension learning involves a holistic approach but may also lead to the use of inappropriate or vacuous analogies without reference to the facts ('Globe-trotting'). Operation learning, based on a serialistic approach allows for the failure to recognise valid analogies and the danger of not appreciating structural relationships ('Improvidence').

To Pask, the ideal learner is one who demonstrates 'versatile' learning using both operational and comprehension learning styles as appropriate to achieve a complete understanding. Therefore it could be suggested that it is Pask's versatile style which should be compared to Marton and Saljo's deep-level processing.

John Bransford who, like Pask, belongs to a very different research tradition from the Gothenburg group nevertheless reports some studies on student learning where his methodology is very similar to theirs. He describes a study concerned with helping school children to learn more effectively (Bransford, 1981). Bransford gave the children a passage to read and study. He then questioned them about the way they had approached the task, and finally gave them questions to test their understanding. Observing the differences between the more effective and less effective learners (as previously defined by the teacher), Bransford reports that the more effective learners seemed to take a much more active approach to learning. By this he means that they would not only attend to factual content, but were also concerned with the 'significance' or 'relevance' of those facts. After follow-up studies exploring learners' ability to recognise difficult texts, he concludes that poorer learners fail to activate their existing knowledge which could help them to understand and remember new learning material.

The degree of overlap in descriptions of learning derived from different methodologies and within different research traditions is remarkable. A number of related dimensions underlie the findings discussed so far:

focus on intentional content	-	focus on surface characteristics
focus on the whole	-	focus on discrete elements
relate to prior knowledge	-	fail to recognise relevance

On the whole the implication is that characteristics appearing in the left-hand column above are more desirable than those in the right-hand column. The work of Pask forms the exception by suggesting that the most effective learner avoids focusing exclusively on either the whole or discrete elements.

#### **The factors underlying differences in approach to learning**

Approaches to learning can be understood in two ways: either as illustrating the learner's response to a particular context, or as an indication of qualities characterising learners themselves. The specific experimental studies discussed so far cannot give a clear answer as to which is the most appropriate explanation because these studies have been conducted in particular contexts. Further work has been done to explore this question, either using experimental situations and manipulating certain variables, or by looking at learning in its normal context.

#### **(A) Studies using experimental manipulation**

It has been observed that at the heart of Marton and Saljo's distinction between deep and surface-level processing lies the learner's intention in approaching the task. This could be restated as 'the learner's definition of the task demands'. In Marton and Saljo's original study, task demands

were deliberately specified only in very ambiguous terms. However in a follow-up study they attempted to manipulate learners' perceptions of task demands by the use of specific types of post-text questions (Marton and Saljo, 1976b). Forty students were randomly assigned to two groups, and both groups were simply asked to read three chapters and expect " to answer some questions on the content after reading each of them." (Marton and Saljo, *ibid.*). One group was given questions designed to induce deep-level processing after the first two chapters, and the other group given questions designed to induce surface-level processing. After the third chapter, both groups were asked to summarise the main points in a few sentences and answer questions to measure both surface-level and deep-level aspects of the content. Finally a semi-structured interview was carried out to gather introspective data on the effect of the experimental manipulation on level of processing.

The effects of these manipulations were most evident from the subjects' reports about the way they approached studying. Under the surface-level condition, all subjects geared their approach to memorising elements of the surface structure of the text (eg. lists of facts). In fact for most students the type of questions asked met their expectations anyway. Those who were not expecting factual questions made quick and effective adjustments. Students reacted in one of two ways to the deep-level condition. There were those who demonstrated a full deep-level approach. Others 'technified' the task demands by focusing on the need to produce a short summary rather than the need to understand *per se*. This difference was apparent in the way the subjects recalled the third text. Those who had adopted a 'technified' deep-level approach tended to mention rather than explain the various topics dealt with in the text.

The evidence suggests that it is easier to induce a surface-level approach than a true deep-level approach to studying. Also, it appears that most students *expect* only surface-level processing to be demanded of them. These two findings lead Marton and Saljo to conclude that,

"While many students are apparently capable of using 'deep' or 'surface' strategies, it may be

that the current demands of the examination system at school level are interpreted by them as requiring mainly the recall of factual information to the detriment of a deeper level of understanding."

(Marton & Saljo, 1976b)

Biggs' work also has a contribution to make to this debate. In this instance Biggs' manipulation was very directive; he instructed one of his experimental groups to concentrate "...on the purpose of the experiment, and the evidence used to draw the conclusion" when reading the first text (Biggs, 1979). Then for the second text, he told them to concentrate "...on the facts and details of the experiment." The second group received the instructions the other way round. Each subject was also asked to complete Biggs' 'Study Process Questionnaire' (SPQ - Biggs, 1978) which measures aspects of motivation and strategy in learning.

In one of the texts Biggs, found clear interactions between instructions, learning strategy (as measured by the SPQ) and learning outcome. The interaction distinguished between learners who were high and low utilisers. (According to Biggs' definition, 'high utilisers' are learners who have extrinsic motivation, a fear of failure, and adopt a fact-rote learning approach.)



Figure 2.1: Utilising X Conditions on SOLO level

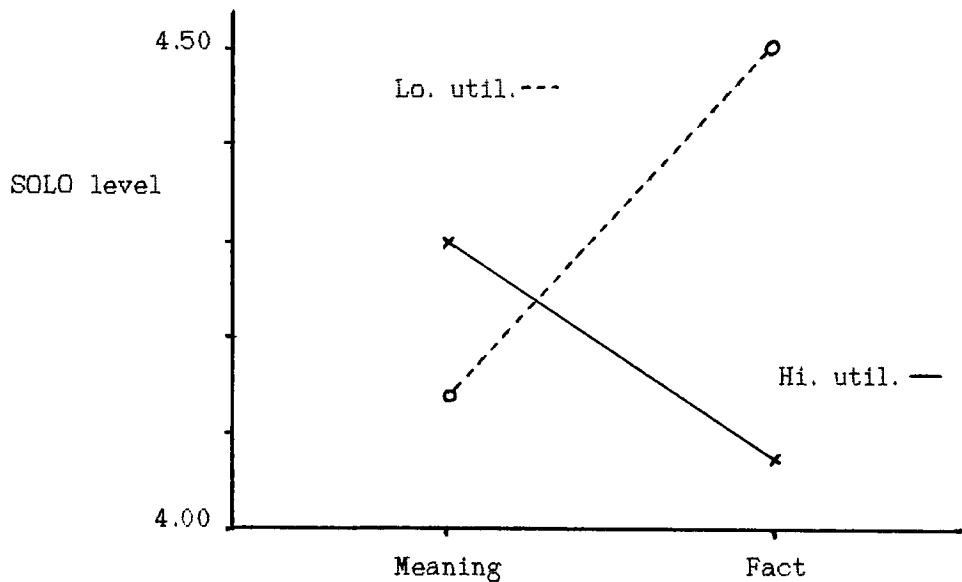

(Biggs, 1979, p390)

In this case those with a tendency towards learning facts demonstrated a lower SOLO level (quality of learning outcome) when instructed to focus on facts than when instructed to look for conclusion and purpose. In contrast, those who had a very low utilisation score and therefore did not normally display a tendency towards fact retention produced much higher *quality* outcomes when instructed to focus on facts rather than focus on the meaning. This could perhaps be an example of the phenomenon which Pask describes as 'versatile learning'. Using this interpretation the low utilisers would be comprehension learners with a tendency towards 'globe-trotting'. In responding to the instruction to pay attention to the facts, they compensate for their weakness by taking a versatile approach and gaining a much higher level of understanding.

Turning to performance on factual tests, Biggs found that high utilisers responded to instructions to focus on facts by successfully recalling many more facts:



Figure 2.2: Utilising X Conditions on Factual Recall

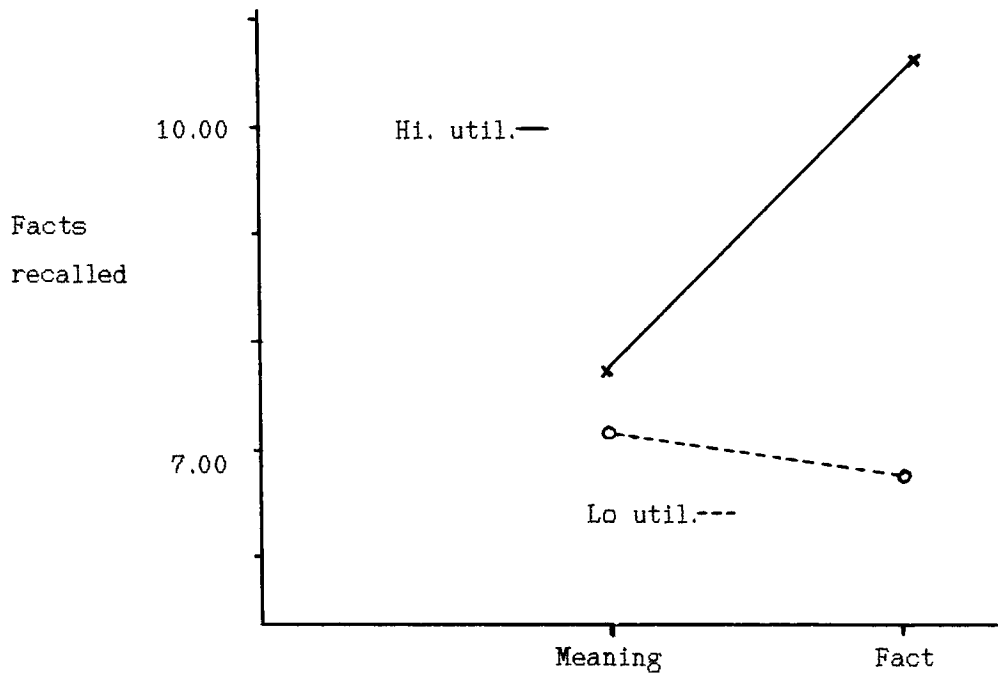

(Adapted from Biggs, *ibid.*, p391)

Low utilisers remembered even fewer facts when instructed to do so than when instructed to focus on conclusion and purpose. This does not seem to match with Marton and Saljo's findings which imply that students normally expecting deep-level processing are more able to adjust to surface-level demands than the converse (Marton and Saljo, 1976b). However the problem might lie with equating 'low utilisers' and 'deep-level processing' purely on the basis of similarity of description.

It is clear that at least in this case it was possible to influence quite substantially the quality of understanding achieved by low utilisers. The method is rather unexpected, by instructing them to focus on facts.

Fransson, another researcher of the Gothenburg group, suggests that possibly the reason for Marton and Saljo's limited success in influencing approaches stems from the fact that they attended to only one aspect of motivation, namely, extrinsic motivation (Fransson, 1977). He argues that the level of intrinsic motivation is likely to have an impact on approaches to study. Fransson provides the following definitions:

*"Intrinsic motivation* is a state where the relevance for the learner of the content of the learning material is the main reason for learning.

*Extrinsic motivation* for learning is a state where the reasons for the learning effort have nothing to do with the content of the learning material. A good learning performance serves merely as a means for achieving some desired end result."

(Fransson, *ibid.*)

Fransson's methodology broadly followed that of Marton and Saljo. He incorporated an attempt to manipulate the dimensions of intrinsic and extrinsic motivation. A special text was written describing the examination system at the Institute of Education at Gothenburg university. Half the subjects came from the Institute of Education and would therefore be expected to have an intrinsic interest in such a text, and the other half came from the Sociology Department and so would be unlikely to have such interest. Half of each of these groups were assigned to the high extrinsic motivation condition and half to the low extrinsic motivation condition. The extrinsic motivation condition involved creating a highly threatening situation in which subjects expected their knowledge of the text to be tested verbally in front of the whole group of subjects and their responses to be tape-recorded in full. In contrast, under the weak extrinsic motivation condition a relaxed atmosphere was created and subjects were told that they would simply be asked to write down what they remembered from the text. In fact all the subjects were treated in the same way, being asked to write a summary of the text and answer some specific factual knowledge questions. Finally all were interviewed about their approaches and experiences of the task. Additionally, a few weeks before the experiment took place, Fransson had

administered a general self-rating questionnaire to all subjects in which were embedded questions about their level of test anxiety.

The analysis of the data based purely on the conditions to which subjects had been allocated threw up some confusing and conflicting results (Fransson, *ibid.*, pp251-253). However, when Fransson re-categorised subjects according to *their* perceptions of the situation rather than *his* definitions of it, the outcomes were much more understandable. This confirmed to him the importance of studying phenomena in terms of the participants' definitions rather than those of the observer. It appeared that

"...expectations built up by previous experiences might sometimes be a more important factor determining the perception of the learning situation of the highly trait anxious student than the actual situation as it is defined by the experimenter."

(Fransson, 1977)

Using learners' perceptions of the situation, Fransson observed that a lack of intrinsic interest, efforts to adapt to perceived task demands, and high trait anxiety all tend to lead to surface-level processing. However, for the learner who *does* have an intrinsic interest in the subject matter, an attempt to adapt to perceived task demands is linked with deep-level processing. This finding appears to reflect the relationship observed by Biggs already discussed. Biggs found that learners with a low fact-retention orientation, like those with high intrinsic interest, when instructed to focus on facts (which is often assumed to be the task demand anyway, Marton and Saljo, 1976b) produce a higher quality of learning outcome.

#### Summary of findings of studies involving experimental manipulation

It appears from these studies that if a learner is not already inclined to adopt a holistic or deep-level approach to a task, then such an

approach cannot be induced simply by the nature of the immediate task demands. However, if a learner does incline towards a holistic approach then appropriate task instructions can improve the quality of learning. In the case of surface-level processing, it appears that this may well be used in response to the learner's perception of immediate task demands.

It seems that the root of the deep or holistic approach must be found outside the immediate situation. Fransson's findings suggest that it may stem from uninhibited intrinsic interest. The corollary to this is that a learner who feels threatened by the situation - a more accurate description of the effect produced in Fransson's experiment than simply 'extrinsic motivation' - is likely to adopt a surface-level approach to learning. This is again evidence that surface-level processing emerges as a result of immediate contextual factors.

#### **(B) Studies focusing on student learning in the normal context**

If the root of the deep approach does indeed lie outside the definition of the immediate situation, then it is necessary to look at learning in its broader context. As Fransson has shown, it is difficult to manipulate broader variables such as level of interest, reliably. Therefore the way forward must be to study student learning in its normal context where the differential effects of various factors can be observed as they occur naturally.

A number of studies focusing on learning in the normal context will be discussed, firstly to establish whether or not the same dimensions of approach to learning apply equally to the normal as to the experimental context. Secondly an attempt will be made to identify the key factors affecting students' approaches to learning.

## 1. Dimensions of approaches to learning

Svensson's study (Svensson, 1977) was designed to look at normal study skills and approaches to learning. In addition to re-working Marton and Saljo's original data, he also asked students about their approaches to normal studying, and obtained data on their examination performance.

Svensson found close agreement between descriptions of approaches to the experimental task and normal study; the same categories of 'atomistic' and 'holistic' were apparent. Moreover, 23 out of the 30 subjects reported taking the same approach in their normal studies as they had during the experimental task.

Marton and Saljo's original work (Marton and Saljo, 1976a) seems to imply that deep-level processing is the most effective approach for a learner to adopt because it leads to higher quality understanding. Svensson's findings confirm this in a wider setting: 10 out of the 11 students adopting a holistic approach to their normal studies passed all their examinations in comparison to 7 out of 19 with an atomistic approach.

Svensson points out that adopting an atomistic approach to study creates cumulative disadvantages for the student. As has emerged from the various experimental studies, 'atomistic' or 'surface-level' approaches tend to lead to poor quality understanding. In addition to this, with university level studies, attempting to take an atomistic approach creates a very heavy workload for the student. Not surprisingly many become overwhelmed by the quantity of information which they perceive that they should memorise. Only a few are prepared to put in the hours that this enormous and tedious task demands.

Ramsden (1979) has explored the relationships between learners' perceptions of their academic environment and their approaches to learning in a study which involved students from six different university departments covering Arts, Science and Social Science students. Part of

his study involved interviewing 60 students "...to see whether qualitatively different learning strategies are linked in students minds with different contexts of learning." (Ramsden, *ibid.*). Once again, he found evidence of a distinction between deep and surface-level processing which reflects that of Marton and Saljo. Ramsden's definitions are, however, broader:

"There seem to be three ways in which a *deep-level* approach is manifested: a tendency on the part of the student to relate the task to personal experience; a desire to make active attempts to relate different parts of the task to each other or to other tasks; an intention to impose a structure on the whole task and think about its meaning."

"In a *surface-level* approach to a task, the student indicates an intention to treat the learning material as an isolated, elemented phenomenon; approaches the task unreflectively or passively; and may try to memorise the material."

(Ramsden, 1979, p422)

These definitions include the aspect of intention identified by Marton and Saljo with the contrasting concern for a search for meaning as opposed to memorisation. They also cover the distinction tapped by Pask, Svensson and Biggs between treating information as isolated elements rather than relating or imposing a structure.

Finally there is a distinction which appears to expand on Bransford's findings (Bransford, 1981). Ramsden observes that a deep-level approach can involve relating the learning material to personal experience. This contrasts with the tendency in a surface-level approach to treat the learning material as an 'isolated, elemented phenomenon' (Ramsden, *ibid.*). Thus it would seem that students taking a deep-level approach are like Bransford's 'effective learners' in the way that they activate background knowledge and relate it to the learning task.

Another study of learning in the normal context was conducted by Morgan, Taylor and Gibbs (1982) to evaluate learning in the Open University.

Their findings take this dimension further, indicating that for some students their learning "...has a quality of personal involvement - the whole person in both his feelings and cognitive aspects being *in* the learning event." (Morgan et al., *ibid.*). Here, not only is the learner relating his personal experience to the learning event, but also making the learning event part of his personal and emotional life. However, this quality was not universal to the deep-level approach; Morgan et al. report that it created a distinction identifying two different types of deep-level approach adopted by their subjects.

The Morgan, Taylor and Gibbs study also introduces a distinction within surface-level approaches. Some learners adopted the classic surface-level approach as described by Marton and Saljo, and also Ramsden, characterised by an emphasis on memorisation and a lack of reflection on the process of learning. However, other learners were very active in their attempts to improve their learning, aware of their weakness and experimenting with different study activities. They could not be described as 'unreflective' and yet they seemed to be locked into a surface approach in terms of trying to memorise rather than seek for meaning.

Before going on to explore further the sources of differences in approaches to learning, it would perhaps be appropriate to summarise the different distinctions identified:



**Table 2.4: Dimensions of Approach to Learning**

---

Focus on intentional content	✓	Focus on surface characteristics
Focus on the whole	✓	Focus on discrete elements
Relate to prior knowledge	✓	Treat as isolated phenomenon
Personal involvement	} ✓ {	Surface-active
✓		✓
Deep-strategic		Surface-passive

---

## 2. Factors influencing approaches to learning

Pask treats the comprehension and operation learning styles which he has identified as characteristic of learners themselves. He demonstrated that, at least in the context of his experimental learning tasks, learning was severely impaired when subjects were asked to learn under mismatched conditions (Pask and Scott, 1972).

In contrast, the Gothenburg group avoid referring to learner characteristics, but claim that it is only possible to observe learner behaviour in specific contexts (Marton and Svensson, 1979, p479). We can deduce from the work already discussed that Marton and Saljo believe that learning approaches are influenced - at least to some extent - by individual's definitions of the task (Marton and Saljo, 1976b). Fransson has demonstrated the influence of the learners' level of intrinsic interest, and their level of perceived threat in the immediate situation.

Diana Laurillard agrees that contextual factors have an important influence on approaches to study (Laurillard, 1979). She argues that investigations into student learning should be conducted within the

normal context in which that learning takes place. Moreover, if the effects of different contexts are to be compared then the learner must be studied over a number of different learning tasks. Laurillard's study involved 31 science undergraduates who were each interviewed three times. They were asked to bring a selection of course work with them which they had been studying no longer than 24 hours before the interview. For each task they were asked to give a 'spontaneous exposition' of the topic and then were interviewed about their approach to that task and their reasons for tackling it that way.

In applying qualitative descriptions to the process of learning, Laurillard suggests a distinction between Pask's dichotomy of operation versus comprehension learning and Marton and Saljo's dichotomy of deep and surface-level processing.

"I would... like to define the 'process of learning' as including at least two aspects: 'executive style' (as in Pask's 'style' and 'strategy', referring to the way the student thinks about the subject matter) and 'strategic approach' (as in Marton and Saljo's 'processing' referring to the way the student approaches the task)."

(Laurillard, 1979)

Analysis of the learners' accounts once again confirmed the existence of a distinction in 'strategic approaches' closely related to that of deep and surface-level processing. The research design made it possible to see that some students do indeed adopt contrasting approaches to different tasks. Nineteen out of the thirty-one used different strategies at different times whilst the remaining twelve appeared to use a deep approach consistently. Laurillard traced the basis of their choice to students' reasons for doing a task, and what they were aiming to get out of it. Her data confirms Fransson's conclusion that intrinsically oriented students will tend to use a deep approach whilst those responding to external pressures who are extrinsically oriented, will adopt a surface approach.

In order to explore 'executive style', Laurillard analysed the transcripts of students' spontaneous expositions of the topics. Once again the data revealed that learners adapted their style to the nature of the topic. They generally used a combination of the operation and comprehension styles with the proportion of each style varying in different topics. Unlike Pask, Laurillard concludes that executive style is not an inherent characteristic but a matter of student choice. According to the students whom she interviewed, teaching style has an important influence on their approach.

Laurillard therefore concludes that both the 'executive style' and the 'strategic approach' adopted by a student do not constitute learner characteristics but reflect learner choice. In the case of 'executive style', choice will depend on the nature of the subject matter, and the teaching style. 'Strategic approach' on the other hand is linked to learners' aims and reasons for studying.

Ramsden's study (ibid.) also confirms that students adopt different approaches in different learning contexts. This was particularly true of science students rather than arts students, who tended to be more consistent. This is compatible with Laurillard's findings which refer only to science students. This issue is pertinent to the present study which is concerned with students of technical subjects who should be akin to science rather than arts students.

There are a number of different ways of interpreting the discrepancy between the faculties. Biggs (1970) argues that study strategies in science are more closely tied to the nature of the specific task. Therefore it would follow that science students would need to adjust their strategies more frequently than arts students.

Ramsden suggests that two factors determine students' approaches to a learning task: their level of background knowledge, and their level of interest in the task. From his data it appears that background knowledge is particularly important for Science students in adopting a deep-level approach, and level of interest particularly important for Arts students.

This could simply be pointing to the fact that the nature of the actual subject matter is most important to the Science student. However, perhaps with the Science student Ramsden is tapping Laurillard's notion of executive style rather than strategic approach. Thus, as she would predict, the subject matter would be influential. The suggestion that Art students are more dependent upon level of interest could be seen in Laurillard's terms as linked with reasons and aims and so with strategic approach rather than executive style.

Alternatively, Bransford's work allows for the suggestion that the difference might be based on the different nature of background knowledge required for Arts and Science subjects. In the case of scientists, relevant background knowledge is likely to be very specific, and perhaps easily identifiable as 'prior knowledge'. In Arts subjects, the concept of relevant knowledge is much broader; most learners will possess knowledge that *could* be applied to any specific topic. The extent to which such knowledge *is* applied will depend on the student's level of interest in the learning task.

The evaluation of learning in the Open University conducted by Morgan and his colleagues focuses on Social Science students (Morgan, Taylor and Gibbs, 1982). Morgan et al. conclude that although most students recognise differences in learning contexts, the degree to which they are able to adapt depends on their conception of learning itself. For example, the learner taking an active surface-level approach which they describe, attempts to improve the quality of his learning in vain. Although he tries new approaches, his intentions to memorise facts do not change because this reflects his underlying conception of the essential nature of learning. Thus he is locked into a surface approach.

Brew and McCormick reach a similar conclusion in an evaluation study of the use of Open University materials in a conventional university engineering course (Brew and McCormick; 1979). They propose the 'iceberg theory' to describe students' conceptions of learning. Some students considered the material presented in the OU texts to be the complete 'iceberg'. They approached learning in a way akin to surface-level

processing, believing that all the material presented should be absorbed and memorised. These students experienced difficulties with the OU texts which included much more detailed material than would an average set of lecture notes. However, students with the opposite approach also found the OU texts very difficult to handle. These students saw the learning materials as constituting merely the tip of the iceberg. They considered that the learning materials, just like a conventional lecture, provide an introduction and a framework on which to build and and develop their knowledge and understanding of the subject. For these learners the OU texts were problematic because they were so closely and carefully argued that there was very little scope for the student to build up an individualised understanding of the subject, relating it to his own particular background knowledge. Brew and McCormick's data indicated that to a large extent learners' approaches to studying depended on the conception of learning which they held.

### Summary and Conclusions

Following this brief review of key studies, it is clear that research taking a phenomenological approach has provided new insights into both *what* students learn and *how* they learn. (Although some would argue that these are not distinct; eg. Svensson, 1977.) The work of Dahlgren (1978) demonstrates the power of a qualitative approach in revealing the content of learning, and has shown this to be superior to a traditional quantitative approach. A number of other researchers have used variations of Dahlgren's design (Marton and Saljo, 1976a&b; Fransson, 1977), but the methodology remains rather vague and difficult to evaluate objectively.

More work has been published using qualitative methods to explore *how* students learn than *what* they learn. A number of descriptive dimensions have emerged (see table 2.4, p57 for the full list) which are closely

related. It appears that learners vary in the extent to which they approach the learning content in a piecemeal fashion, or take a broader view, being concerned with the whole. Although there are important differences in the various definitions which have been developed, their proximity is striking. However, at this stage, much of the research has concerned university undergraduates, with the occasional study looking at school children. It will be necessary for the present research to establish the dimensions which can be used to describe how *technician* learners approach studying.

Furthermore, the present research is concerned not only with describing learning, but also with identifying *effective* learning. Some relationship between approach and quality of learning has been established. For example, in an experimental situation, Marton and Saljo demonstrated a correlation between deep-level processing and high quality understanding. The work of Svensson (1977) also demonstrates a link between academic success and the use of a deep-level approach. On the other hand, Pask argues that it is the versatile student, employing both serialist and holist styles who is the most effective learner (1976). The relationships between qualitative descriptions of learning approaches and the effectiveness of learning need further clarification.

Another key question to be addressed is: what factors influence the approach which a learner adopts? Pask treats the approaches of serialist and holist learning as characteristics of learners themselves. A number of other researchers have investigated 'learning styles' seeking to identify the way learners consistently differ in their approaches to learning tasks (Eg. 'Field-dependence/field-independence', Witkin and Moore, 1977; 'Syllabus-bound/syllabus-free', Parlett, 1970; 'Cue-consciousness', Miller and Parlett, 1974). Large scale questionnaire studies by both Entwistle (Entwistle and Wilson, 1977) and Biggs (1978) have combined many of the dimensions developed by others to explore learner 'types' through cluster analysis. Both programmes of research have independently suggested that there are three learner types (amongst populations of either university students or school children). Students tend to take either a personal and deep approach, a surface and

extrinsically motivated approach, or are strategic and concerned with academic achievement. Entwistle outlines the factors listed in each cluster as follows:

**Table 2.5: Clusters emerging from study strategy scales of the Lancaster Inventory**

---

Cluster 1:	Deep approach Comprehension learning Intrinsic motivation Internality Openness
Cluster 2:	Surface approach Operation learning Extrinsic motivation Fear of Failure Syllabus-boundness
Cluster 3:	Strategic approach Organized study methods Achievement motivation Disillusioned attitudes Sociability

---

(From Entwistle et al., 1979)

Theorists such as Laurillard (1977) would argue that approaches to learning are not characteristics belonging to a learner but the response of a learner to a particular situation. Aspects of the situation which have emerged as significant include: the nature of the topic and the teaching methods (Ramsden, 1979; Pask, 1976); the extent of the learner's background knowledge (Bransford, 1981); the learner's aims in studying (Biggs, 1978; Laurillard, 1977); and the learner's interpretation of the task demands (Marton and Saljo, 1976b; Brew and McCormick, 1979).

Investigations of the influence of learners' interpretations of task demands have shown them to be less amenable to manipulation than was expected (Marton and Saljo, 1976b; Biggs, 1979). It appears that individuals bring to a learning situation a particular conception of the nature of learning itself which delimits the possible ways in which they can approach the task (Morgan et al., 1982; Brew and McCormick, 1979). Various studies of university students have directly addressed the issue of conceptions of learning. Perry (1970) followed a group of students throughout their college life and observed that their conceptions of learning became more sophisticated. They moved from a very dogmatic view of learning as being the transfer of facts from teacher to taught; to an appreciation of the relativistic nature of the content of learning and sometimes ultimately reached a point of willingness to be committed to a particular opinion. Saljo (1979a&b) reports a study of a wide cross-section of university students from which emerged a similar spectrum of conceptions of learning. In describing the distinctions Saljo focuses on the extent to which learning itself is recognised as a legitimate object for reflection.

It is clear that the phenomenological approach to research into student learning addresses many of the issues that were raised in the first chapter of this thesis. A new methodology is being developed which promises to provide insights into the quality of students' learning, and the significant dimensions which distinguish their approaches. Moreover, some of the findings begin to suggest practical strategies for the improvement of learner effectiveness (eg. attention to background knowledge for Scientists; help with developing conceptions of learning; matching of strategies to the structure of the topic; attention to aims in studying). However, most of the studies quoted are small scale and none of them has focused on a population of technician learners. Therefore it cannot be assumed that the various insights emerging are relevant to this study. Instead, it would be appropriate to apply the methodology of phenomenology directly to the investigation of technician learning in the Open Tech.



## CHAPTER 3

### A METATHEORY OF RESEARCH INTO LEARNING

As a result of the initial consideration of the research problem itself and a review of the relevant literature, a proposal has been made. The proposal is to apply the methodology of phenomenology directly to the study of technician learning in the Open Tech. This methodology is not however simply a technique which can be substituted for other approaches as a matter of convenience. It constitutes what Snow (1973) has termed a 'metatheory'; it involves a set of philosophical assumptions which shape the questions which can legitimately be asked, the appropriate methods of investigation, and the rules of theory building which apply.

Of course all research falls within a metatheory of some kind. However, the application of a phenomenological approach to learning research is relatively recent. Therefore it is considered important in the context of this thesis to make the metatheory explicit. This will make it possible to ensure that a consistent set of assumptions underlies the research; that the methodology adopted is appropriate to those assumptions; and that the true status of the research outcomes is recognised and can be attributed its correct place within research in the field as a whole.

This chapter will first examine the basic philosophy of phenomenology, and then various psychologists' interpretations of it. The discussion will be used to extrapolate a number of assumptions regarding both the nature of man and the nature of science that will underlie and guide this study.

## Fundamental Phenomenology

The phenomenological approach to the study of human learning is underpinned by the principle that human behaviour is guided by man's experiences of the world rather than caused by events in the world. This principle derives from the philosophical debate about the ontological status of the world we experience.

The phenomenologists would point out that an object will look different depending upon the exact angle from which it is viewed. I might see the table top as brown, whereas to you it might appear to be white because of the way the light is reflecting off its surface (Russell, 1967). As the table cannot actually be both white and brown in the same spot at the same time, it could be argued that it is not the table itself that we are seeing, but our perceptions of it. Thus it must be concluded that we cannot know the world directly, but only indirectly through our experiences or perceptions of it. Hence the phenomenological view: that man's behaviour is guided by his experiences of the world rather than the world itself.

If this philosophical debate is pursued to its conclusion, it leaves the scientist with a fundamental problem concerning possible knowledge of the world. If we agree that we can only have indirect knowledge of the world via our perceptions of it, how can we really be sure that there is a world somehow beyond and independent of our perceptions? We will never be able to confirm the accuracy of our experiences against some independent criteria of the real world. Therefore we are faced with Descartes' dilemma (1642); we must accept the possibility that there is no real world, and the only existence that I can be sure of is my own and that of my thoughts. If this is the case, how can I as a scientist purport to study anything but the contents of my own mind?

The problem can be resolved by tracing a few steps backwards in the original line of reasoning. It was suggested that because two people's experiences of the same object at the same time are different and can be

incompatible, then they cannot both be seeing the same thing. In explanation a new set of 'things' was postulated, namely 'perceptions'. Thus it was claimed that we do not experience the real world itself, but only our perceptions of it. However, the problem can be more easily resolved by simply accepting that the same object **can** give rise to different experiences. In other words, the table can look different from different angles. This interpretation treats 'experiences' or 'perceptions' as the mind's response to an object and avoids creating this new world of things called perceptions which in their turn have to be experienced by the conscious mind.

This study will be based on the assumption that people's experiences of the world will always be different, and that behaviour will be in response to these unique interpretations of the world, rather than any objective characteristics of the **real** world (if it exists).

### **Phenomenology in Psychology**

So in this research we accept at least the minimal phenomenological claim that behaviour is guided by the way man interprets the world. This means that in studying behaviour it will be vital to attempt to understand the way in which man interprets the world. Here we are not of course referring to the exact physiology of perception (ie. the functioning of the eye, ear etc.), but how perceptual data is used to create a picture of the world. Or - to put it another way - how experience becomes meaningful.

It is mainly social psychologists who have taken a phenomenological approach and pursued the study of meanings. For example Bogdan and Taylor outline the way in which symbolic interactionists analyse behaviour:

"... people are constantly in a process of *interpretation and definition as they move from one situation to another... All situations consist of the actor, others, their actions and physical objects. In any case, a situation has meaning* through people's interpretations and definitions of it. Their actions in turn stem from this meaning. Thus, this process of interpretation acts as the intermediary between any predisposition to act and the action itself."

(Bogdan and Taylor 1975 p14, original italics)

Here there is an emphasis on situation, and meaning is seen in terms of the meaning of a situation. As Backman (1979) points out, the whole movement towards a more phenomenological approach in psychology is characterised by this shift of emphasis from individual variables to situational variables. Ethnographers for example, would argue that the context will generate regularities in human behaviour often transcending individual differences. In other words, behaviour is largely influenced by the nature of the situation in which the individual is placed, and to a lesser extent by that individual's personal characteristics. The classic example is the interview situation where the very subtle differences in the way individuals act become very important because overall their actions are so similar. This suggests that most individuals interpret this situation in the same way and this shared meaning (interpretation) guides them to behave in the same way. Therefore the ethnographers would argue that it is not possible to understand behaviour without understanding the framework with which individuals interpret their experiences.

Most phenomenological psychologists focus their attention on the discovery of this framework. Backman (1979) suggests that the main task is '...to look for the normative structure underlying social life'. Ethnomethodologists place emphasis on '...understanding the meaning structure of everyday life...' (Cohen and Manion, 1985). Marton (1981) defines the task of his particular version of phenomenology - *Phenomenography* - as '...to find and systematize the forms of thought in

terms of which people interpret aspects of reality.' Harre (1972) and Argyle (1979) see man primarily as rule-governed. Argyle points out that people will actively seek to discover the rules of a situation, and can sometimes explicitly state them. Both he and Harre place particular emphasis on the tendency of a social group to apply sanctions when rules are broken, and they investigate this phenomenon as a means of access to the rules themselves.

This notion of 'rules of behaviour' or a shared 'interpretive framework' has proved very fruitful in the development of our understanding of social behaviour. Although, as Argyle (1979) acknowledges, rules are more dominant in some situations than others. It tends to be in more formal situations where norms of behaviour are very clear cut and hence an individual's behaviour conforms to a pattern determined by the situation. The less formal the situation, the more scope there is for individual differences to emerge, and the less predictable behaviour becomes.

In applying the phenomenological paradigm to research into learning, psychologists have recognised that learning behaviour is itself influenced by socially learnt rules. This is particularly apparent when considering formal classroom learning. It is clear that the child's response to a book placed in front of her on a desk is not purely innate. The school child learns an appropriate response from both the teacher who directs, and fellow pupils who provide an example. Gradually, through a process of socialisation the child builds up an understanding of what learning means, incorporating those learned rules. This understanding is carried over to new learning situations - such as studying through the Open Tech - and used as an interpretive framework by which to deduce the demand characteristics of the situation.

## The Nature of Man

If we are to accept the phenomenological analysis of the nature of man as a being whose actions are guided by his interpretations of the world, we must not only pay attention to the nature of those interpretations, but also to how they are generated. As Schutz the early existential phenomenologist recognised, the attribution of meaning to events - particularly those involving the actions of others - is problematic (Cohen and Manion, 1985). Others' actions are ambiguous and the attribution of meaning is an achievement. Yet it is also of vital importance to men, as Claxton (1984) so clearly outlines:

" What I do depends on what my theory tells me about the world, not on how the world really is..."

"...what happens **next** depends on how the world really is, not on how I believe it to be."

He uses the example of a hologram which I believe to be a chair. According to this belief, my action might be to attempt to sit on it. However as a result I would fall down, because it is not really a chair. It would not support me simply because I **believe** that it is a real chair.

This analysis stems from Kelly's *Constructive Alternativism* (1963) involving a conception of man as a scientist. Kelly sees man's motivating force as the making and testing of theories about the world. The criterion of a good theory is that it is helpful in enabling the individual to select the appropriate actions to promote his own survival.

## The origins of meaningfulness

It is clear that the attribution of meaning is very important. Earlier the example of the formal interview was used. A candidate knows how to behave because of certain expectations that he or she associates with the concept of 'interview'. But how did he or she develop those expectations? No doubt the individual draws on past experience - both his or her own and that of others. But how did he or she know how to interpret those earlier experiences? Bernstein (1974) criticises the phenomenologists' emphasis on the meanings of situations because they overlook the fact that this

"...presupposes a structure of meanings (and their history) wider than the area of negotiation. Situated activities presuppose a situation; they presuppose relationships between situations; they presuppose sets of situations."

We must therefore underpin our analysis of the notion of 'meanings' with an explanation of how the pre-socialised individual breaks into the world of meanings.

It will help our discussion if we look at the nature of meanings themselves. Let us compare two descriptions of a situation;

[a] Her arm moved rapidly forward and made contact with his face.

[b] She slapped him angrily.

(Harre and Secord 1972)

Description [a] attends to the physical aspects of the event and should be an adequate description according to a mechanistic model of man. However this example illustrates how the mechanistic paradigm breaks down, for it does not help us to predict the response to this action. We can only begin to understand the event with description [b] because this provides us with an indication of the intentions behind the action. We can now appreciate the range of responses likely to follow.

Understanding the intentions of other actors appears to be a key factor in attributing meaning to a situation. This provides us with at least a plausible explanation of how the individual begins to attribute meaning in the first place. Prior to his or her appreciation of the meanings of situations, an individual has access only to his or her own disjointed perceptions and needs. It could be argued that it is through the experience of these personal needs that the individual is able to attribute needs, and thus the intention to fulfil those needs, to others. Thus it seems that this empathising might enable us to endow the actions of others with meaning and thus break into the world of meaning.

Man as an Actor not a Reactor.

Near the beginning of this chapter the analysis of behaviour as proposed by symbolic interactionists was outlined. In the ensuing discussion attention has focused on the process of interpreting situations, as this was acknowledged to be a key to understanding behaviour. However, it may be necessary, but it is not sufficient. A common sense reflection will reveal that simply being able to interpret a situation will not of itself lead me to act. Symbolic interactionists would hold that "...this process of interpretation acts as an intermediary between any predisposition to act and the action itself." (Bogdan and Taylor, 1975).

So what of this 'predisposition to act'? According to a mechanistic paradigm, actions occur in response to a stimulus of some kind. In contrast phenomenologists take the view that man generates his own behaviour through the making and pursuing of plans to achieve his own goals. Thus, when a child puts her hand up in the classroom, this could be seen as a response to the stimulus of the teacher asking a question. Alternatively, it could be seen as an action prompted by the child's intention to try to answer the teacher's question. This is not simply a semantic difference of description; it holds powerful implications about the causal relationships in operation. In the former, mechanistic paradigm, the teacher's question is the **cause** (or one of the causes) of



the child's behaviour. In the latter case, from a phenomenological perspective, the teacher's question is the **reason** (or one of the reasons) for the child's behaviour.

The notion of 'cause' involves a direct and necessary relationship between one event and another such that the effect - child raising hand in the air - is **determined** by the cause - teacher asking question. Patterns of cause and effect relationships together form natural laws. Natural laws are laws which describe the way things are, such as the law of gravity or the boiling point of a liquid. If exceptions to these laws are observed then the law itself is called into question. This contrasts markedly with the notion of 'reasons'. Reasons do not have in themselves the power of causation, although they do serve to guide in the same way as rules (as in fact reasons may derive from rules). If rules are broken, or unreasonable or irrational behaviour is observed, it is not necessarily the rules themselves which are questioned. Instead either the observer's appreciation of the event may be questioned or the actor him or herself. Transgression of the rules of behaviour within social settings are characteristically followed by sanctions such as Harre (1972) and Argyle (1979) have made the focus of their investigations.

Social rules versus Natural law.

Phenomenologists generally take the view that on the whole human behaviour is governed by reasons rather than laws. However, few would go as far as to deny the role of natural laws altogether. Symbolic interactionists tend to distinguish between the social world and the natural world. They suggest that behaviour within the social world is governed by rules, and within the natural world by laws. However this creates a dilemma. On the one hand it is hard to deny that for example, instincts such as self preservation or procreation have a part to play in determining human behaviour. On the other hand, if we do accept this, it becomes very difficult to distinguish which behaviour should be interpreted in which terms. Harre (1972) illustrates the problem using

the example of a 'slip of the tongue', and also the accidental dropping and breaking of a vase. Both these instances might appear to exemplify law governed behaviour because they are non-deliberate acts. Yet 'slips of the tongue' are often referred to as *Freudian slips* because at least Freud - if no one else - attributed meaning to them. The case of the accidental dropping and breaking of a vase is also contentious. If such accidents happened frequently to one individual, that person would be likely to be labelled as 'careless', and at least in some sense held responsible for his or her actions. This implies that according to common sense, such behaviour would be perceived as rule-breaking. Although it is clearly not intentional behaviour in the sense of being deliberate, neither can it be analysed in purely mechanistic terms. The only option seems to be to acknowledge that both natural laws and social rules have an influence on human behaviour which will of course include learning behaviour.

#### Man as a learner

This exploration of the nature of man has led to two major conclusions. Firstly, it has led to the view that man is not simply a reactor to stimuli but also (and mainly) an actor pursuing his own plans and goals. Secondly, the conclusion is reached that man's actions are mediated by his interpretations of the world rather than prompted by stimuli from the world itself. Accordingly, it must be accepted that the utility of his interpretations is vital for man's survival. Furthermore, it follows that the developing and testing of interpretations or theories of the world is of central concern.

This view suggests that learning itself is of central concern to man because finding out about and adapting to the world is essential for survival. This research therefore, in addressing the problem of effective student learning, should not be looking for ways of **teaching** people to learn, because the ability to learn is a fundamental human characteristic. It should instead be questioning why this fundamental ability of man is not exercised more effectively in the situations that have been defined

as learning situations. It should be seeking to identify the factors which inhibit learning.

### The Nature of Science

A broadly phenomenological stance has been taken in making assumptions about the nature of man. Therefore, to be consistent, the inquiry itself must also be conducted from a phenomenological perspective. However this poses serious problems for the scientist. It has been demonstrated that phenomenology implies that we cannot have access to the 'real' or objective world, but only our perceptions of it. If we cannot even be sure that the real world exists, how can we claim to be contributing to knowledge about it? In resolving this issue this thesis appeals to a common sense view of the world. It is accepted that although the existence of objective reality cannot be **proved**, there is no more reason to doubt it than believe it. Therefore the thesis will proceed on the basis that the common sense view is both reasonable and workable, and acknowledge the limitations of this basis when applying the theory.

This reasoning approaches a position very close to Kelly's theory of *Constructive Alternativism* (1963). It accepts that it is never possible to prove that a theory is true - in other words is an accurate representation of objective reality. Yet it argues that theorising is still worthwhile if it can help us to cope with the world. The criterion of a good theory would then be utility rather than validity. The aim of this study should therefore be to develop a useful and appropriate model (or theory) of technician learning in the Open Tech.

In the next section the positivists' claims to validity will be examined in comparison with a phenomenological approach to scientific inquiry.

## The implications of a mechanistic model

Positivists - unlike phenomenologists - would see their empirical data as constituting facts about the world. They would aim to determine the laws governing reality by exploring the relationships between those facts. Their analysis of human behaviour does not differ from that of other aspects of reality in that human behaviour is also assumed to be governed by laws. Thus we arrive at the so-called 'mechanistic model' of man where man is a highly complex machine.

In attempting to understand a machine, it makes sense to break down the more complex processes into their component parts. These more simple processes can then be understood more clearly and the exact nature of the principles upon which they work established. The appreciation of the functioning of the whole machine - however complex - could in theory be built up from a systematic analysis of its component parts. Following this reasoning, the emphasis in positivistic psychology is on isolating specific components of behaviour and using experimental manipulations to measure these precisely. The study of animal behaviour also contributes to the science as a way of looking at less complex examples of the machine.

This approach makes the assumption that the relationships between the components parts of behaviour are 'external'. This means that each element is discrete and remains in itself essentially the same even when combined in different ways with other elements. It contrasts with 'internal' relationships where any single element can only be defined in terms of its relationship with others. In this case the element will not remain the same if its relationship with other elements is changed. Bradley (1908) states the distinction clearly in philosophical terms:

"If a term *A* has an **external** relation *P*, then the term remains *A* irrespectively of having or not having *P*."

"If a term *A* has an **internal** relation *P*, then any thing which had not *P* would necessarily have been different from *A*."

The phenomenologist would argue that behaviour can only be understood within a particular context. This implies that relations within behaviour are internal. For example, waving is not the same element of behaviour when demonstrated by the Princess of Wales from an open carriage as by the merchant seaman's wife at the quayside. If we believe that elements of behaviour are linked by internal relations with one another and their context, then it is not valid to separate them in order to study them. Hence research conducted within the phenomenological approach is generally concerned to study behaviour within a normal context. There is an emphasis on making experimental manipulations as naturalistic as possible, but preferably to study behaviour as it occurs naturally, often using case studies or participant observation.

#### Cause and effect

There are also important differences in what the researcher is aiming to achieve, depending upon a positivist or anti-positivist stance. These differences are not simply because of the diverse methodologies employed, but also have a philosophical basis. Positivism embodies a normative approach to science, which, in psychology, involves the establishing of the laws or 'norms' which govern behaviour. Laws are identified by investigation of the patterns of cause and effect relationships involved in behaviour. These are measured precisely by using quantitative data and finding statistical correlations. So descriptions of relationships can be given, which are very precise at least in numerical terms.

However this is where the problem lies, because statistical correlation can only establish causal relationships in the very limited Humean sense. That is, correlation can establish '...the tendency for one thing to follow another' (Harre 1972). This is not the same as our common sense notion of cause which involves an idea of causal connection, whereby *A* makes *B* happen. The interpretive paradigm appears to come much closer to exploring cause and effect in common sense terms.

An interpretive approach to science seeks to understand or interpret the relationship between *A* and *B*. The question is, 'why does *B* follow *A*?' This approach is more appropriate to the understanding of the nature of man in this thesis. It has been suggested that man's behaviour is not only governed by laws but also guided by reasons. Therefore we shall be seeking to explain behaviour in terms of the reasons why it occurs.

#### The status of results

The outcomes of anti-positivist and phenomenological research tend to be in the form of descriptive categories which can be used to classify or theorise about behaviour. Such qualitative description can be contentious because it appears to be rather imprecise to those more used to the quantitative statements of the positivist tradition.

The ideas of Glaser and Strauss have had an important influence on methods of qualitative research through their book *The Discovery of Grounded Theory* (1967). Their particular quarrel is with the positivist tendency to base theory on arbitrary *a priori* assumptions about the nature of the phenomenon under investigation. Therefore they propose that theory should be 'grounded' in the empirical data. They stress the importance of avoiding imposing structure from without and allowing descriptive categories to emerge from the raw data itself. Their methodology of comparative analysis has enriched the work of many phenomenological researchers in developing descriptive categories which are empirically based.

Yet the question still remains; can descriptive categories be the final results of research, or are they simply a stage along the way? Positivists see the development of categories as a step towards quantifying originally qualitative data, so that ultimately the theory can be tested statistically. Glaser and Strauss also seem to assume that theory - even though 'grounded' in the way they suggest - needs to be tested according to the normative approach. In contrast, Marton and

Svensson (1979) are anxious to point out that in their work the categories of description are the final product. It would be inconsistent with the anti-positivist stance to attempt to demonstrate that the theory embodied in a set of descriptive categories, forms a general law underlying behaviour. The interpretive paradigm does not accept the existence of general laws underlying behaviour. Marton and Svensson are also wary of attempting directly to transfer category definitions developed in one context to another, in order to 'test' their validity. This would violate the nature of the internal relations. They are interested to explore similarities between contexts as long as the theory is grounded in the new data each time and not imposed upon it .

#### Ontological status

Another source of confusion is the ontological status of categories of description. Marton (1981) introduces the distinction of the *1st order perspective* and *2nd order perspective* in research. Research in the 1st order perspective is concerned with the real world of physical objects. This seems to match with positivist research as we have described it where research questions are pursued by measuring the physical world, and research findings purport to describe the real world. Marton considers this to be a legitimate research approach and places it parallel with - not in opposition to - research in the 2nd order perspective. The latter is concerned, not with the world itself, but with how people experience the world. Research is pursued by finding out how people experience the world, and outcomes are in terms of descriptions of the nature of experiences. Marton's own research takes a 2nd order perspective and he describes it as *Phenomenography*. He argues that this is not the same as *Phenomenology* because phenomenologists study people's experiences of the world in order to find out about the real world (ie. 'real' behaviour). He studies people's experiences of the world because these experiences are of interest in themselves.

Marton is suggesting that phenomenologists are sometimes in danger of confusing the ontological status of their results. He uses the example of Piaget's work on cognitive development. Piaget's early work was conducted from a phenomenological perspective, finding out from children how they perceived various aspects of reality such as differences in shape or size. Through this he was able to build up a hierarchy of children's ideas about various concepts. Marton's criticism is that Piaget then goes on to claim that he has in effect discovered 'brain structures'. Piaget (1954) suggests that the categories represent developmental stages in the child. This leads him into problems, because later research has revealed that children's performance varies enormously according to the nature of the task. This is predictable according to the phenomenological view of man that situational variables dominate over individual variables in guiding behaviour. But it forces Piaget to make cumbersome additions to his theory. Marton would argue that instead the solution is to recognise that Piaget's categories of children's conceptions describe forms of thought, or ways of thinking about the world, rather than developmental stages which actually characterise the child's brain development.

This example highlights the importance of being clear about the nature of the information that we have access to in phenomenological research. The phenomenologist tries to understand behaviour by finding out about the ways in which people interpret the world. Bogdan and Taylor (1975) suggest that their task is to "...capture the process of interpretation of the world." Even this seems to be making an unjustified assumption. As Argyle (1979) points out, we do not have access to the causes of behaviour (or the underlying processes), but only to the cognitive products. These cognitive products are part of the **outcomes** of the process of interpretation of the world, not the **process** itself. Perhaps we should even be wary of claiming to discover the 'forms of thought'. Through our investigations we can learn of our subjects' ideas, and through analysis give those ideas shape and form. We can never tap directly into the process by which they were formed.



## Subjectivity

The most common criticism of phenomenological research as a scientific method is that it is not objective; it is subjective and as such is not scientific. There is no doubt that phenomenological research is subjective in the true sense of the word. Phenomenologists are primarily concerned with anything "... belonging to the consciousness rather than external objective reality" (Concise Oxford Dictionary), their focus of study is the products of the mind.

Nevertheless it is an important concern, as with all science, that the research be free from experimenter bias. This poses serious problems for phenomenologists because, as Weber (1968) claimed, in order to appreciate the way another person views the world we need to see things through their eyes. Weber called this process of empathising '*verstehen*'. The researcher actually has to use his or her own human-ness in order to understand another human being fully. It might be recommended that in order to avoid the bias of the experimenter's interpretation, all verbal reports of subjects be taken at face value. However this would mean that even devices such as irony would have to be ignored. This would obviously violate common sense, and is likely to lead to serious misrepresentation. Yet, moving towards the other end of the spectrum allows for increasing interpretation or speculation about the 'real' meaning behind the words. This gives scope for strong experimenter bias and makes the research process itself essentially subjective.

It is not only phenomenological research that is prone to subjectivity. Harre and Secord (1972) argue that positivist research only gives an illusion of objectivity. They cite the influential role of the researcher in designing an experiment, or deciding which aspects of a phenomenon to focus on in a particular study. This part of the scientist's role is often ignored, and yet it has a powerful influence on the nature of the results. The conclusions of the research can only be concerned with those aspects of behaviour which the researcher chose to measure.

This leads to another distinction between the two research approaches. According to the positivist tradition, the final analysis is in terms of the researcher's interpretation. His understanding is seen as paramount, and certainly superior to that of his subjects, who are only considered to have a partial appreciation. For phenomenologists the subjects' own interpretations are paramount. For this reason it has been claimed that phenomenological research is less subjective in terms of experimenter bias than positivist research. However, this is slightly misleading because subjects' interpretations are paramount since they are the actual raw data of the study. The researcher will still take an overview and interpret the data in a way considered to be superior to that of any individual subject.

One of the main challenges facing the phenomenological researcher still remains, and that is to avoid imposing interpretations on the data. As we have pointed out, understanding another human being is an essentially subjective process. The challenge has been faced in different ways. Ethnographers attempt to 'bracket' their preconceptions. This involves suspending judgement whilst the data are being collected. Some follow Glaser and Strauss (1967) in advocating that data collection and analysis be undertaken concurrently so that it is the interpretations based on the data itself, which inform further data collection. Most would acknowledge that it is impossible to approach any research with a true *tabula rasa*. Even the language we use structures the way we experience the world, and therefore the way we understand the experiences of others. Kelly (1955) uses this quality of language in the exploration of personal constructs. The *Repertory Grid* technique capitalises on use of language by mapping out an individual's definitions of terms.

Thus in various ways, the degree of subjectivity is reduced. However ultimately it must be accepted that complete objectivity can never be truly achieved either in the positivist or anti-positivist research tradition.

## **The Nature of our Inquiry**

To recap; the present inquiry concerns the study of learning amongst technician learners enrolled for open learning courses under the Open Tech. The objective outlined in the original research contract was to

"...develop guidelines for design, based on a thoroughly researched understanding..."

This thesis accounts for the development of that 'thoroughly researched understanding', and this chapter has considered the basic assumptions which underly the approach adopted. In conclusion the main parameters which guide the research will be drawn out below.

### **(1) Learning is a fundamental characteristic of human nature.**

Learning has been equated with the developing and testing of theories about the world, which is seen as an essential process for survival. Therefore it must be a fundamental characteristic of human nature.

It follows that we should not be seeking primarily to **teach** learning behaviour, but to understand why its natural occurrence is inhibited. It is also acknowledged that formal learning in the context of an open learning course is a social phenomenon. Learning in this context should therefore be understood both as instinctive and social behaviour.

### **(2) Man's behaviour is guided by his interpretations of the world.**

The phenomenologists' stance has been adopted, claiming that people experience the world in different ways. It is these experiences rather than the world itself which guides their behaviour.

In order to explore learning behaviour, the ways in which people experience learning must be explored . An attempt will be made to describe the forms of thought by which this population of students conceptualise learning.

**(3) Man is an actor not only a reactor.**

Man is viewed as a free agent whose actions are prompted by the pursuit of his own intentions - they are not determined by response to stimuli.

An analysis of learning behaviour would not be complete without an account of the intentions which have prompted the individual to act.

**(4) Analysis will take the form of the interpretation of examples of behaviour.**

The interpretive rather than normative research paradigm is more compatible with the above analysis of the nature of man. Therefore no attempt to establish general laws underlying learning behaviour will be made. The aim will be to understand examples of learning behaviour occurring within the context of this research.

**(5) Results in terms of categories of description are meaningful.**

Categories of description will not be treated as theory to be tested, but as results.

Categories describing people's experiences will not be assumed to indicate physical differences in the 'real' world. However their relationship to events in the 'real' world - such as behaviour - will be explored and stated. Any theory emerging from the research will be judged on the criterion of utility rather than validity.

**(6) Objectivity in science concerns the avoidance of experimenter bias.**

The focus of this research is essentially subjective because it is concerned with the products of the mind. However experimenter bias will be avoided by giving priority to allowing learners' interpretations rather than the researcher's interpretations to emerge.

## CHAPTER 4

### APPLYING THE METATHEORY TO TECHNICIAN OPEN LEARNERS: DESIGN OF STUDY 1

#### Aims of the Study

Before outlining and considering the aims of the main study in detail, the argument so far will be reviewed. The objective of the project funded by the Manpower Services Commission was to draw up guidelines for the design of open learning for technicians based on a thoroughly researched understanding of how technicians learn. A review of the literature directed the study to take a qualitative look at how technicians experience learning. The phenomenographical approach of the Gothenburg group lead by Ference Marton appears to provide a promising methodology to explore learners' experiences. In chapter three the philosophical implications of phenomenology as a metatheory for learning research were considered. It was concluded that the present study should explore the meanings and intentions underlying technician learner behaviour in the Open Tech, with a view to developing descriptive categories which could contribute to theory building. It should be noted here that all the learners studied in this research were male. Learners are therefore referred to as 'he' throughout the thesis. This is partly for convenience, but also to remind the reader of the specific context to which all observations refer.

In the study published in 1976, Marton and Saljo (1976a) provide a model for the phenomenographical study of student learning. They used what may

be termed a naturalistic experiment. Students were asked to complete a task set by the experimenter which was designed to reflect a normal study task as closely as possible. It involved the reading of a text at an academic level appropriate to the students' studies, followed by the answering of open questions to elicit their understanding of the text. Students were given only very general instructions on how to complete the task in order that they might be free to make idiosyncratic interpretations of the task demands. Finally students were interviewed about their experiences of the task.

The use of an experimental task could be criticised on the grounds that removing the learning event from its normal context interferes with the integrity of the research. The problem can be avoided by interviewing students about their approaches to normal study tasks (eg. Laurillard, 1979 and Svensson, 1977). However, Marton and Saljo favoured the use of an experimental task because it allows for control over the content of the task, and the conditions under which the subject tackles it. In addition, it minimises the time lapse between the experience of the learning event and the interview concerning it. In addition Marton and Saljo were later able to introduce certain experimental manipulations into the original design to pursue particular questions (eg. Marton and Saljo, 1976b).

The present study is particularly concerned with exploring the intentions and meanings which characterise technicians' experiences of learning. It is clear that the intentions associated with an experimental learning task will normally differ from those associated with tasks undertaken in the course of normal study, and it cannot be assumed that the same is not also true of meanings. It was therefore decided that this study would incorporate an investigation of both an experimental learning task and learners' experiences of their normal studies. The design of the experimental learning task would be based on Marton and Saljo's original design but adapted to be appropriate to the academic level of technician learners. It would provide examples of learning outcomes which would be comparable across subjects. The interview would then cover both learners' recent experiences of tackling the experimental learning task and their

experiences of normal studying, and the different accounts could then be compared.

### **Selection of subjects**

#### Choice of population

This work is particularly concerned with identifying the barriers to effective learning experienced by Open Tech technicians. However at this stage the Open Tech itself was not yet launched, therefore it was necessary to identify and study a group of learners who most closely resembled the characteristics anticipated of the Open Tech learners. The British Telecom technicians training by distance learning scheme was identified as an appropriate context within which to work. This is a correspondence course dealing with work-related technical training. As a result students tend to hold technician posts within the company (eg. repairing cables, maintaining exchanges, installing domestic equipment). The course has been running for a long time so there should no longer be any 'teething' problems. The evidence of the Gothenburg and Surrey studies (ibid.) which use this paradigm suggest that a workable and fruitful number of subjects for such a study is between 20 and 30. In practical terms the course was convenient because a large number of students are enrolled each year, therefore it would not be difficult to find enough students following the same course. Students are administered by a nationwide network which could be used to arrange interviews.

Agreement in principle to the study was made with the staff organising the course at the British Telecom Training College, Stone.



## Choice of specific context

The next step was to identify which of the course units (a particular programme of study leading to an examination and forming part of the modular structure of the course) would be the most appropriate context in which to work. In consultation with the College, the unit *Telecommunications Systems I* was selected. This is a basic level course usually undertaken during the first or second year of study. It is general rather than specialised thus attracting a good cross-section of students. This means that it also had the advantage of not being too technically sophisticated and so the content was easily comprehensible to the interviewers.

In his introduction to this unit the course editor outlines its aims:

"... this course is aimed at introducing you to the main forms and systems of communication used in the field of telecommunications. The course takes a broad look at the subject and in doing so prepares the way for more detailed study in later courses."

(Odell, 1980)

Topic headings include *Information Transmission; Radio; Television; Radar; Telephony and Telegraphy; and Data Transmission*. The course is designed to take 60 hours study time to complete, spread over one academic year. Passing the course contributes the value of one unit towards a Technician Education Council (TEC) qualification.

*Telecommunication Systems I* (TS1) is made up of a large number of short 'segments' of between 7 and 15 pages (see appendix 1 for sample segment). Each segment covers a discrete (but related) topic and includes the following elements:

Framework (plotting the context of this particular segment in the course as a whole.)

Teaching material text (including diagrams and graphs.)

Summary of main points

Self-assessment questions

Self-assessment question answers

Students receive batches of these segments through the post to their homes each term. The course runs from September to June each year in line with the Further Education Colleges' terms which provide the administrative and tutorial support. Normally students have at least one face-to-face tutorial at the College each term for which they are given 'day release' from their work. Tutorials take the form of a classroom question-and-answer session, involving all the students based at the College plus the tutor. Students are also offered the facility of telephoning the tutor at particular times at the College if they need extra help. Each term they are required to complete a homework task which is handed in to the tutor and marked, although in the case of TS1 it does not contribute to the final assessment. Assessment is based on performance in tests taken at the College at the end of each term ('phase' and 'end' tests).

#### **Design of the learning task**

One of the most important design criteria for the task was that it should reflect students' normal learning tasks as closely as possible for reasons of ecological validity. In selecting a text, Marton and Saljo (ibid.) chose material which included a fairly complex argument reaching a number of conclusions. The same principle was followed in this study, taking into account the different conceptual level of the normal learning materials studied by these technicians as opposed to university undergraduates. A single segment of the materials appeared to provide an appropriate focus for the learning task. Such a segment would normally comprise a few pages of text including various diagrams and tables, followed by a summary of the main points, and finally a number of self-

assessment questions (SAQ's). Many segments were quite long and covered a number of separate, though loosely linked topics. However, a suitable segment was identified in the Data Transmission section: 'How Computers Process Information', segment 3, section F (see appendix 2). This is a relatively short segment, but covers some fairly conceptually sophisticated ideas all concerned with the central topic of how computers process information. Furthermore, it came from towards the end of the course so no students would have studied or even had an opportunity to look at it before.

When used in the learning task the segment was slightly altered:

- A small section at the end introducing the terms 'Bytes' and 'Words' was deleted because it added only factual information rather than conceptual sophistication.
- The Summary was deleted so that students would use their own criteria for identifying the main points of the segment.
- The SAQ's were omitted.

The learning task was given about one third of the way through the interviews rather than at the very beginning. Deliberate attempts were made to develop a relaxed atmosphere so that findings were as little affected by anxiety as possible. Interviewers introduced the task in the following way:

"I'd like now to ask you about the way you normally study the materials in Telecommunications Systems I. In order to help you think about that I am going to give you an extract from the course materials which you will be studying later in the course. It is part of a segment about computers and it is self-explanatory.

(Hand over learning task materials - appendix 2)

Please read this through and learn it.

Take as long as you like, and when you have finished give the booklet back to me. Then I would like to ask you about it.

Here is a pencil and paper if you should need them."

(Interview Schedule p3, see appendix 3)

All interviewers were instructed to follow the above script as closely as possible, but in a relaxed and conversational manner. The instructions were also printed on a piece of paper attached to the front of the learning task materials which were retained by the learner.

Having introduced the task, interviewers then left the room suggesting that students call them back when they were ready. This was to minimise the social pressure which learners might experience to finish the learning task as quickly as possible rather than when they felt they had learnt it to their satisfaction.

#### Measures of learning outcome

Two measures of learning outcome were designed, one qualitative and the other quantitative.

##### *1. Qualitative measure of learning outcome*

The aim of the qualitative measure was to provide an opportunity to discern 'differences in *what* is learned ...(by looking for)... examples of distinctive qualitative differences in how students grasped or comprehended ideas and principles' (Marton and Saljo, 1976a, p4). In addition, in this study a high priority was given to the avoidance of influencing or structuring the content of the learner's response, therefore the following question was asked:

"In a minute I would like you to explain to me in your own words the main points which were

made in the passage you have just read. Explain it to me as if I know nothing about how computers process information.

Take your time in thinking about what you would say.

If you prefer, you can write down your explanation."

(Interview Schedule p3, see appendix 3)

This question avoided suggesting what might be the key idea in the segment, apart from referring to the title again which had already appeared on the front of the segment, but it gave the opportunity for learners to demonstrate their understanding of the ideas and principles involved. The word 'explain' was used in the task because it was felt that this would be a familiar task for technicians who are often required to give apprentices and other trainees on-the-job advice. Students were encouraged to collect their thoughts before attempting the task so that they would have opportunity to structure their ideas. The option of writing down the explanation was given so that the task would not be prejudiced against those who were more at ease expressing themselves on paper than orally.

Interviewers were instructed only to encourage students during their explanations by showing interest, using non-evaluative responses. Interviewers did not press a student for further explanations once the student had indicated that he felt that the explanation was complete (or at least as much as he could give).

## *2. Quantitative measure of learning outcome*

To provide a contrast with the qualitative measure, a quantitative measure was also developed. This was designed to reflect the emphasis of normal SAQ's on information retention and recall. The questions were presented on a separate piece of paper in the style of SAQ's (see appendix 4).

Interviewers gave the following instructions:

"Here are a few short written questions, could you fill in the answers please?"  
(Interview Schedule p4, see appendix 3)

Students completed these and then handed them back to the interviewer who did not comment on the answers unless requested to do so.

### Design of the interviews

The use of verbal reports as a source of data is contentious. Nisbett and Wilson (1977) opened the debate by questioning the accuracy of retrospective verbal reports about causal influences on mental processes. On the basis of the inaccuracy of causal reports, they argue that 'there may be little or no direct access to higher order cognitive processes.' (ibid., p231). It follows that learners have no access to their own *learning* processes and thus it is not valid to use their introspections as a source of data.

If the Nisbett-Wilson proposition is accepted then the interview becomes an inappropriate tool for this research. However, in the intervening years the Nisbett-Wilson paper has been disputed on a number of grounds. Most notably Ericsson and Simon (1980) have published a critique based primarily on a re-examination of the original empirical data. They argue that although examples of inaccurate verbal reporting can be found, this does not provide sufficient evidence to negate the validity of all verbal reporting. They suggest that accurate verbal reporting can be relied upon under certain conditions. The most important condition is that the reporting should only concern aspects of a task which the subject has actually attended to in the course of completing the task. This will be

information which has passed through the short-term memory and is therefore available for recall. They suggest that a request for concurrent verbalisation provides the best conditions to access accurate reporting of the contents of short-term memory. Retrospective reporting is more likely to be incomplete or inaccurate, but can be made most fruitful by the use of open questions which invite the subject to report only on the aspects of a task to which he or she attended. Closed questions tempt the respondent to fill in memory gaps by theorising and using generalisations. Ericsson and Simon also report a study which demonstrates that an oral response is much more likely to be accurate than a written report because the latter appears to carry evaluative and moral overtones (Silviera, 1972).

White (1988) raises a number of questions of definition which demonstrate ambiguity in Nisbett and Wilson's argument. White queries the use of the term 'mental process', arguing that a clear distinction cannot be made between 'content' or 'knowledge' and 'process'. Nisbett and Wilson accept that certain aspects of mental knowledge are accessible to introspection:

"The individual knows a host of personal historical facts; he knows the focus of his attention at any given point in time; he knows what his current sensations are and has what almost all psychologists and philosophers would assert to be "knowledge" at least quantitatively superior to that of observers concerning his emotions, evaluations and plans."

(Nisbett & Wilson, 1977, p255)

However they distinguish between these accessible 'personal facts' and process which they assert to be inaccessible. Marton takes a similar stance in describing his methodology:

"To ask the students to describe how they had been handling the learning task is to some extent tantamount to asking them how the learning task and the learning situation appeared to them, because it is the only language in which questions about what we do when we try to learn by reading a text can be answered. Answers to such questions are *not* of an introspective nature; there is just no way

in which we can look into ourselves. What we can do instead is to say how the world appears to us and this was exactly what the students did in our experiments."

(Marton & Saljo, 1984, pp37-38)

Marton appears to be of the opinion that it is only people's experiences of the world (content) which are accessible, and not the production of those experiences (process). In following Marton, the concern of the current research is also to look at learners' experiences themselves rather than the cognitive processes underlying them. In fact these concerns are closely reflected in Nisbett and Wilson's list of accessible 'mental knowledge': the interviews were designed to investigate learners' meanings (their 'evaluations') and their intentions (their 'focus of attention' and their 'plans'). Thus in the context of this debate it is not disputed that the interview is an appropriate tool where the research is concerned with subjects' perceptions themselves as primary data, rather than as an indicator of cognitive processes beyond. However it is important that such a position is maintained consistently, and any conclusions drawn are also only concerned with perceptions and not cognitive processes.

Fleming has raised further problems with the use of interviews, particularly criticising recent phenomenographical research (Marton, Hounsell & Entwistle, 1984) for treating the interview as 'analytically transparent' (Fleming, 1986, p550). Phenomenographers acknowledge that learning occurs within a specific context and must be interpreted in this light. Yet they have tended to ignore the fact that the descriptions of learning which they use as their data also occur within a specific context - that of the interview. Fleming points out that in an interview, the learners' accounts of their experiences primarily fulfil a social function; the learners' concern to represent their experiences of learning accurately is only of secondary importance. Researchers must not therefore assume that the interview transcript provides a complete and accurate representation of how the learner experienced the learning event. Social actions are moral actions and the learner is conscious that value judgements are being made about him on the basis of his account. These



moral overtones can be minimised by avoiding presenting the interviewer as an authority figure and also by avoiding giving any evaluative feedback during the interview. However the essentially social nature of the interview must be acknowledged. The dimensions emerging from learners' accounts must be seen as a reflection of what they consider to be normal and acceptable learning experiences rather than raw, unfiltered experience itself.

In designing the interviews to take account of the points raised in the discussions above, guidance was sought from the experiences of social psychologists, and Merton's 'Focused Interview' (1946) was identified as an appropriate model. Merton outlines an approach which involves using a semi-structured interview keeping directive questioning to a minimum, but focusing on a number of experiences which all respondents have shared. In this case the shared experiences would be the experimental task itself and also the experience of studying the same Open Tech course. 'Open' rather than 'closed' questions were used because the rationale of the study is to elicit the ways in which learners themselves structure their experiences, there are no *a priori* hypotheses as such to be tested. However, the questions asked reflected certain expectations about the relevance of particular topics; questions explored learners' accounts of their behaviour in the contexts listed, and the meanings and intentions which they attributed to their behaviour.

In looking at intentions and meanings both in the experimental learning task and normal studying the scope of this study is broader than the original Marton and Saljo study. The research design has therefore also been influenced by the work of Taylor et al. on the study of intentions in studying; Laurillard on approaches to normal studying; and Saljo on conceptions of learning. The opening questions probed learner's reasons for studying; their previous experiences of work-related studying; and their general reactions to the particular course. This was followed by the presentation of the learning task and the two measures of learning outcome. Immediately after the learning task learners were asked about their approach to the task and the ways in which they had interpreted its demands. The next section focused on normal studying on the course,

asking learners to describe and account for their activities. Finally interviewers were directed to ask learners to compare their experiences of this form of open learning with face-to-face learning. A complete copy of the interview schedule can be found in appendix 3. Appendix 5 presents a question by question account of the rationale underlying the details of the design of the interview schedule.

Learners were only available on one half day, when they attended the College for their tutorial session. Therefore it was decided to train four interviewers who could conduct the interviews concurrently in the three Colleges agreeing to participate in the study. All the interviewers were experienced in general interviewing. However they were prepared for participation in this study through detailed discussion about the aims of the study, the nature of its design and the implications of the focused interview and open questions for interviewing technique. Particular emphasis was given to the creation of a relaxed atmosphere and the avoidance of communicating any evaluative judgements on the learners' remarks.

The nature of the study as theory-generating rather than hypothesis-testing meant that it was important that no assumptions were made about relevant and irrelevant data prior to the complete analysis. This precluded the possibility of recording interview data directly on to categorised recording sheets. Therefore it was necessary to tape-record each interview in full and then transcribe it and use the transcripts for the data analysis.

### **Procedure**

Permission was granted to interview a total of 24 students, roughly 8 from each of three participating Colleges:

Peterborough Technical College  
Mander College, Bedford  
The Colchester Institute of Technology

The procedure was as follows:

1. Interviewers attended normal College tutorial sessions and were introduced to the group by the tutor who also handed out introductory letters (see appendix 6) explaining the nature of the research and asking for volunteers.
2. Volunteers attended interviews individually in private rooms (either an office, interviewing room or empty classroom).
3. Interview topics were then covered in the following order:
  - Introductions asking for learners first name only and reassuring them of the confidentiality of the interview.
  - Permission requested to use tape recorder.
  - Questions on the course in general (Section A of interview schedule).
  - Learning task, followed by the qualitative then quantitative measures of learning outcome.
  - Questions on the learning task (Section B of interview schedule).
  - Questions on studying a normal segment of the learning materials, on completing the homework and on preparing for the phase test (Section C of interview schedule).
  - If time allows, question on general reactions to doing a correspondence course.
  - If for some reason the qualitative measure of learning outcome failed to produce an explanation of the learning material, an alternative question was asked.
4. Each interview took between a half and three-quarters of an hour, and was recorded in full. Complete transcripts of the interviews were subsequently made from the tapes and these were used for data analysis.

## **CHAPTER 5**

### **ANALYSIS AND PRESENTATION OF RESULTS: STUDY 1**

Within the phenomenological research paradigm, the derivation of the categories of analysis of the study are considered to be as important to its evaluation as the results themselves. Therefore the process of data analysis will be described in detail and will incorporate a presentation of the results. The interview transcripts were analysed to examine learning outcome using both qualitative and quantitative measures. In addition, approaches to learning were investigated employing questions of theoretical interest and questions of practical interest. Each of these aspects of the analysis will be discussed in turn.

#### **(A) Analysis of Learning Outcome**

##### **1. Qualitative Measures**

Three different approaches to analysing the quality of learners' understanding were developed. The first was derived from the Marton and Saljo model; it arrived at a qualitative assessment of learning outcome by a judgement of the proximity of the learners' understanding to the

intended meaning of the learning material. The second reflected a conventional approach to essay-type marking. The third used a taxonomy developed by Biggs (1982) to describe the 'Structure of Observed Learning Outcome' (SOLO).

Quality of learning outcome: Measure A

*(Derived from the Marton & Saljo model)*

In developing the Marton and Saljo approach a careful analysis of the method described in the 1976a paper was made, and a number of procedural steps were identified. These included reading through the responses of each of the learners in order to discern the way in which that individual has comprehended the particular idea under consideration (no *a priori* categories are imposed on the data). Then responses are grouped according to the similarity of their comprehension of the key idea or principle. Finally, the groups (or categories) are arranged in an order which reflects the quality of understanding demonstrated, as judged by their proximity to the intentional content of the learning material.

This procedure, when used to evaluate quality of learning outcome in the present study yielded six different categories. Each category represented qualitatively distinct ways in which this group of learners had understood how computers process information. Categories varied in the content and sophistication of their accounts of concepts such as binary numbering and its relationship to computers' use of electrical on/off states; the role and meaning of a code; the mechanics of punch cards and paper tape feeds (see appendix 7 for a complete description of the category definitions which were developed). Hierarchical relationships between the categories have been suggested, derived independently by the researcher and a computer expert and based on proximity to the intentional content of the learning material. The six different categories were then labelled 'A' (most sophisticated) to 'F' (least sophisticated) as shown in table 5.1, page 103.

Objectivity of categorisation was attempted by comparing the researcher's with two other independent ratings. Learners' responses were allocated to the different categories by the researcher and then two independent raters each of whom dealt with only half of the data. Inter-rater agreement between rater and researcher was in both cases only at the 50% level. This does not of course indicate random assignment of categories because there were six and not just two categories to choose from. However it was felt that a higher level of agreement should be pursued.

After discussion with the two raters it appeared that most of the problems had been caused by misunderstandings of the category definitions. The written descriptions of the categories were amended in the light of these discussions. It was decided that raters should not be expected to rely purely on the written descriptions, but must also be trained by the researcher to use the categories.

Two further raters were therefore trained. They each read the category descriptions, and then fed back their understanding to the researcher at which point any confusions were clarified. They were then given a sample transcript to classify and discussed any difficulties experienced in identifying the appropriate category. Both raters then classified all the data independently. The results were analysed for agreement by the Kendall coefficient of concordance ( $W = 0.842$ ).

**Table 5.1: Quality of learning outcome: Measure A**

<i>Learner No.</i>	<i>Outcome</i>	<i>Learner No.</i>	<i>Outcome</i>
1	C	13	C
2	A	14	C
3	C	15	B
4	F	16	E
5	F	17	A
6	D	18	C
7	D	19	A
8	B	20	A
9	E	21	D
10	A	22	B
11	C	23	C
12	A		

Quality of learning outcome: Measure B

*(Conventional essay type)*

A second marking scheme was developed to reflect the conventional approach to essay-type marking. In contrast to measure A where the categories were derived purely from the data, measure B was initially based on an analysis of the learning material itself. With the assistance of the computer expert three key topics were identified in the content of the message, and a scoring system was developed which reflected the importance of the various aspects of each topic. The computer expert was asked to share a total of 15 points appropriately between the three sections, and then allocate points for level of understanding within each section (a complete copy of instructions given to the computer expert plus the points which he allocated can be found in appendix 8).

This marking scheme was then used to evaluate each learner's understanding of the learning task. The results were as follows:

**Table 5.2: Quality of learning outcome: Measure B**

<i>Learner No.</i>	<i>Score</i>	<i>Learner No.</i>	<i>Score</i>
1	6	13	3
2	9	14	6
3	6	15	7
4	1.5	16	3
5	1.5	17	7.5
6	5	18	3.5
7	3.5	19	9
8	9	20	8
9	6.5	21	3
10	7	22	4.5
11	2.5	23	3
12	7.5		

Quality of learning outcome: Measure C  
(Biggs' SOLO Taxonomy)

The categories involved in measures A and B depend very much on an analysis of the *content* of learners' explanations of the topic. The third marking scheme used in this study was based on a measure developed by Biggs (1982) which emphasises structure: the SOLO (Structure of Observed Learning Outcome) taxonomy. A full description of this taxonomy is provided by table 2.2, page 41.

Learners' explanations of the topic were found to fall within Biggs' category definitions with all but the least sophisticated, pre-structural,



response represented. Examples of the data illustrating the different categories can be found in appendix 9. Table 5.3 below presents the classification of the entire data set.

**Table 5.3: Quality of learning outcome: Measure C**

<i>Learner No.</i>	<i>SOLO Level</i>	<i>Learner No.</i>	<i>SOLO Level</i>
1	R	13	MS
2	EA	14	R
3	MS	15	R
4	US	16	MS
5	MS	17	R
6	MS	18	MS
7	R	19	R
8	EA	20	EA
9	MS	21	MS
10	MS	22	MS
11	MS	23	MS
12	R		

## 2. Quantitative measure of learning outcome

The original version of the test (see appendix 4) was used with 8 learners during the first set of interviews. The feedback from the interviewer debriefing indicated a lack of clarity in question 3 (50% of learners had experienced difficulties in understanding the question). The test was therefore amended, and the new version was used in the remainder of the interviews (test B, see appendix 10). For the purposes of analysis the tests were scored as follows:

*Test A:*

- Question 1 - 1 mark for identifying 'b' and only 'b' as the correct answer. (No marks deducted for incorrect answers).
- 2 - Total of 3 marks available; 1 each for filling in the following: *paper tape*; *punch cards*; and *magnetic tape*.
- 3 - Excluded from the scoring scheme.
- 4 - 1 mark awarded if either 'a' or 'b' are identified as correct. (No marks deducted for incorrect answers).

*Test B:*

- Question 1 - 1 mark awarded for identifying 'b' and only 'b' as the correct answer. (No marks deducted for incorrect answers).
- 2 - Total of 3 marks available; one each for filling in the following: *paper tape*, *punch cards*, and *magnetic tape*.
- 3 - 1 mark awarded for identifying 'b' and only 'b' as the correct answer. (No marks deducted for incorrect answers).
- 4 - Excluded from the scoring scheme.

The final 'quantity of learning' score was then derived by adding up all the marks gained by each learner and giving them a score out of a possible total of 5. The data is presented in table 5.4 below:

**Table 5.4: Quantitative measure of learning outcome**

<i>Learner No.</i>	<i>Score</i>	<i>Learner No.</i>	<i>Score</i>
1	5	13	5
2	4	14	missing
3	4	15	5
4	4	16	5
5	5	17	4
6	4	18	5
7	missing	19	5
8	5	20	4
9	4	21	3
10	5	22	5
11	5	23	5
12	5		

### **Analysis of Approaches to Learning**

In attempting to analyse the data from the interviews there were three concerns:

1. To follow up the main questions of intention and meaning in learning, underlying the interview design. (These underlying questions are outlined in the description of the interview design, appendix 5.)

2. To examine issues raised by interviewees which had not been anticipated by the original design.
3. To gather data on a number of practical issues concerning the implementation of open learning systems.

All these concerns were respected in developing a checklist of issues to be explored. The questions underlying the design became the basis of the checklist. The questions of theoretical interest provide different ways of exploring technician learners' intentions and meanings in studying. Question 1, 'What reasons does X give for studying?', gathers together data on learners' intentions in undertaking the TS1 course. Questions 2 and 3 represent two different approaches to the identification of the conception of learning underlying the learners' approach to the learning task. Question 2, 'How does X define learning in the context of the experimental learning task?', purely uses learners' own explicit attempts to define the meaning of learning as used in the learning task. Question 3 is modelled on the work of Marton and Saljo in exploring the focus of attention revealed as learners explain how they tackle the learning task. Question 4 then moves on to include not just the learning task but the learner's entire account of his learning experiences. This is used to build up a complete picture of the meanings which a learner attaches to the concept of learning. Question 5 looks for the extent to which variety of conceptions is reflected in a variety of study activities. Finally, although question 6 was not anticipated it became apparent from the data that learners vary in the extent to which they feel in control of their learning, and this is seen as an aspect of their conception of learning.

The questions of practical interest arose from the ultimate aim of the research of providing practical advice and strategies for improving the design of Open Tech courses. Question 7 seeks to discover the extent to which learners already use the study techniques or strategies taught in a conventional study skills course or text book. This is partly of theoretical interest in looking at the factors influencing the

effectiveness of learning. Also, it is of practical relevance in designing learning materials and advising course tutors. Question 8 looks specifically at the ways in which learners use self-assessment questions (SAQ's). It could be that SAQ's provide an opportunity to influence learners' approaches to a task. The last question, 9, addresses the issue of learner-tutor contact. Many open learning courses appear to leave the initiative to the learner to seek help and support when needed. This data was explored to find out how successful this approach was in this context.

The following checklist constitutes a list of particular questions to be asked of the data:

#### **Questions of theoretical interest**

1. What reasons does X (individual subject) give for studying?
2. How does X define learning in the context of the experimental learning task?
3. On what does X focus his attention when studying the learning task?
4. What are X's general conceptions of learning?
5. Does X vary his approach in different learning situations?
6. To what extent does X feel in control of his own learning?

#### **Questions of practical interest**

7. Does X use any study techniques or strategies such as might be taught in a conventional study skills course or book?

8. Does X use the SAQ's (self-assessment questions)? If so, why?
9. Does X contact the tutor when experiencing difficulties?

At this stage it was not appropriate to adopt the approach of conventional content analysis and draw up *a priori* definitions of the data which would be considered relevant to each question. Therefore each transcript was read through and notes were taken on aspects of the data relating to each of these questions. Some of the checklist questions could be answered by looking at the learner's answer to a particular interview question. However, most of them could only be answered by appealing to the transcript of the interview as a whole. The notes included direct quotations, abbreviated descriptions and the researcher's reflections. Gradually operational definitions were evolved and descriptions of these are given with the discussion of data relevant to each question. When all the data had been covered for each group of questions, the notes were examined for each question separately. Once again, the making of *a priori* assumptions about the content of the data relating to each question and the sort of dimensions which might be used to describe it, was avoided as far as possible. The data was read and re-read, searching for patterns or groupings emerging. Sometimes data appeared to fall into a number of distinct groups, and when this occurred an attempt was made to describe or define the group boundaries and identify where each unit of data belonged. The definition of a 'unit of data' varied with each question and so will be specified as appropriate under the particular question concerned. Where distinct groups (or categories) have been identified a second rater has been used to check the reliability of the descriptions.

However, much of the data could not be described by a comprehensive system of categories, for example, a dimension only apparent in some of the transcripts or a particular circumstance of great significance to only one learner. It was considered important not to discard such data at this exploratory stage of the research.

The results of this process of analysis are now discussed question by question. The content of the data will be described, and where appropriate particular categorisation systems outlined. This constitutes the presentation of results of this study. The next chapter, 'Discussion: Study 1' will explore relationships between the different issues and consider the implications.

### Questions of Theoretical Interest

#### 1. What reasons does X give for studying?

The interview opened with the direct question, why are you studying this course? The inquiry was then followed up with a series of questions exploring the full range of the learner's reasons, and any further benefits in studying of which he was aware. Responses to all these questions, plus relevant information volunteered later in the interview were taken into account in compiling a complete picture of each learner's reasons for studying. The range of reasons is first listed and then elaborated below.

The range of reasons:

Vocational	- Promotion	(19 learners)
	- Job security	(2)
	- Job prospects	(3)
	- Improved performance	(17)
Interest in subject		(2)
Enjoyment of studying		(3)
Belief in the value of education		(5)

Study as mental exercise	(4)
Studying for the sake of the children	(3)

***Description of the types of reasons emerging***

*(a) Vocational reasons*

A large majority of the learners (82.6%) quoted promotion aspirations as one of their main reasons for studying. Often this was their first response to the question of why they were studying. Generally an explicit link was made with the need to attain qualifications in order to be promoted within British Telecom (77.7%). For example, learner 12 reported

"Basically I've been told that I can't get any promotion without tickets."

(No 12, p1)

This impression appeared to be very widespread and is illustrated again by learner 18 who responded to the question; 'why are you studying this course?', in the following way:

"It's because all other people round me are getting more qualifications, and to compete for any sort of promotion later on I need to get some qualifications."

(No 18, p1)

Other learners made the more general point that studying "... looks good on your records." (No 13, p1). (See also learners 4, 9 and 14)

It was interesting to note that quite a number of learners (7) felt that promotion prospects in British Telecom were not very good. This number even included learners who had presented promotion aspirations as one of their main reasons for studying. Learner 19 aired his doubts:

"Well (I'm) sort of aiming at promotion, but whether it comes about in the current climate or not I don't know."

(No 19, p1)



Apparently in response to the same fears, two learners (Nos. 1 and 2) mentioned concerns of job security.

"... I think if I can get a few qualifications I might safeguard my job. I might get a bit of promotion, but really, the way things are going I shan't ever get promotion I don't think. It's getting a bit tight."

(No 2, p1)

Three learners felt that if their promotion prospects in British Telecom were not very good, at least the qualifications may help them to get a job elsewhere.

"Well... I don't know where I'm going to go next. I mean if something unforeseen happened and the department I'm working in went down the drain, I might have to find somewhere else to go. The more you've got behind you, the more you know, the more possibilities of getting work somewhere."

(No 5, p2)

(See also numbers 16 and 17)

In addition to discussions regarding the benefits of acquiring the qualifications, learners were asked if they felt that the content of the course itself was helping them in their work. 52% felt that the course was helping their performance at work in a number of different ways:

"There is another reason in fact; it gives me a deeper insight into my work, which is a good thing."

(No 1, p1)

"... you can relate more to your job - you know - if you know the background of how the system works. It's easier to talk to other people if you know what you're talking about."

(No 10, p1)

Int.: "Are you getting anything else out of it?"

Lnr.: "Well yes - I know what I'm doing. I can look at a pair of wires and basically... I can know

where it comes from and what it's going through, and what's its end route."

(No 3, p1)

"I think mainly it was to give an insight into the stuff we don't see in our particular job... more technical, a look at the other side."

(No 13, p1)

Five learners (22%) expected that what they were learning now would help with their work in the future, particularly on promotion. Learner 23 gave his reasons:

"Because if I've got chaps who work under me who have been brought up in telephones... I've got to know what I'm talking about."

(No 23, p1a)

(See also numbers 18, 20, 21 and 22)

However a further 26% said that what they were learning on the course was of no use at all in their jobs. These learners (numbers 4, 5, 9, 17, 19 and 21) felt that they were able to do their jobs already and simply needed the qualifications on paper. Sometimes this applied to older men who had learnt the job a number of years ago before the qualifications were introduced. For example, learner 19 was asked if he was getting anything else out of the course apart from the qualifications.

"Me personally, not really. It's just a bit of paper, and perhaps a quick refresher of things I've done many moons ago."

(No 19, p4)

Another example is that of learner 5 who had worked in telecommunications in Australia and then moved to Britain, only to find that his qualifications were not recognised by British Telecom (No 5, p1).

Although vocational reasons such as those described above were dominant, and usually (though not always) mentioned first, learners gave a wide variety of other reasons for studying the TS1 course.

*(b) Interest in the subject*

Two learners seemed to be particularly interested in the subject itself, not just because it was job-related. For example learner 3 who was asked:

Int.: "Would you be interested in doing the course even if it wasn't for promotion?"

Lnr.: "Yes, I think I would, because I'm interested in... the technical side of it."  
(No 3, p2)

(See also number 10)

*(c) Studying as a hobby*

Three learners were partly taking the course because they enjoyed studying, or were happy that it gave them something to do.

"... primarily 'cause I like doing them."  
(No 9, p1)

"More or less it's just something to do, like. If you've got two hours to fill in... these courses, I think they're all right."  
(No 4, p1)

(See also number 8)

*(d) An educational opportunity*

Two learners saw the TS1 course as a chance to compensate for earlier educational opportunities missed. For example learner 17 argued that he was studying the course:

"... basically to catch up on what I missed at school I guess."  
(No 17, p1)

(See also number 9)

A further two expressed a belief that education is good in itself and opportunities should not be wasted. For example both learners 2 and 10 always try to be involved in some sort of educational pursuit:

"I was going to the Tech' anyway. I've always tried to do something like that, I've been to evening classes before."

(No 2, p1)

Learner 5 states his philosophy explicitly:

"... any form of study is good anyway, I'm that way inclined."

(No 5, p1)

*(e) Study as mental exercise*

Five learners indicated this reason, which is closely linked with the one above. For example, learner 5 goes on to explain why he thinks that, 'any form of study is good':

"To me study is a thing that keeps your mind active... keeps you alert to anything. It doesn't matter what you're learning, so long as you keep thinking about something."

(No 5, p1)

Learners 6, 8 and 14 seem to share his view. For example learner 8 explains that;

"I'm keeping myself occupied, you know. I'm getting my mind working again and things like that..."

(No 8, p2)

*(f) Studying for the sake of the children*

Three learners (numbers 5, 6 and 9) hoped that their own efforts to study would provide a good example for their children to follow. This is explained by learner 6:

"I suppose the main reason was for the kids really. I thought it was necessary for them to see me, or someone else in the house, doing some sort of studying."

(No 6, p1)

*Taylor's 'Orientation' categories*

In order to compare this population of technicians with Taylor's findings relating to the 'orientations' (or reasons for studying) of university students (Beaty nee Taylor, 1978 & Taylor, 1981), an attempt was made to use Taylor's categorisation system with this data.

*Table 5.5: Definition of Taylor's categories*

ORIENTATION	INTEREST	AIM	CONCERNS
VOCATIONAL	intrinsic	training	relevance of course to career
	extrinsic	qualifications	recognition of worth of qualification
ACADEMIC	intrinsic	follow intellectual interest	room to choose work, stimulating lectures
	extrinsic	educational advance	grades, academic progress
PERSONAL	intrinsic	self improvement	challenge, interesting material
	extrinsic	proof of capability	feedback, passing course
SOCIAL	extrinsic	have a good time	facilities for sport and social activities

(Taylor et al., 1981)

**Table 5.6: Examples from this data set illustrating Taylor's categories**

---

<i>Vocational Extrinsic:</i>	"Well, it's mainly for promotion. I think that's the only way you're going to get on." (No 10, p1)
<i>Vocational Intrinsic:</i>	"It gives you an insight into the job which is helpful." (No 2, p2)
<i>Academic Extrinsic:</i>	No instances
<i>Academic Intrinsic:</i>	"I'm interested in... the technical side of it." (No 3, p2)
<i>Personal Extrinsic:</i>	"Well, education... I was stupid when I was younger, I missed out. I got chucked out of College and Tech'. This is like another chance for me." (No 2, p1)
<i>Personal Intrinsic:</i>	"I'm getting my mind working again." (No 8, p2)
<i>Social:</i>	No instances

---

All the reasons given by each learner were classified according to Taylor's categories as defined above (recognising that a single sentence may well express more than one reason for studying). On the whole the comments slotted into Taylor's categories very easily. However a number of observations should be made, in some cases leading to minor revisions of definition.

*Categories not used -*

There were no examples of the *Academic extrinsic* category. This generally refers to the desire to achieve academic attainments that will be recognised by others, and so includes qualifications. Although the desire to achieve qualifications was mentioned quite frequently by learners, in this case it was impossible to isolate the qualifications themselves from the vocational purposes that they were perceived to serve. Perhaps this demonstrates the fact that these technicians were more able to specify the way in which they expected the qualifications to be valuable than were the university students.

There were no examples of the *Social* category. This might be expected, as the very nature of a distance learning course tends to isolate learners rather than giving them extra opportunities for social interaction.

*Extra dimensions in this data -*

A number of learners seemed simply to enjoy learning as a hobby. This appears to be a personal reason (rather than 'academic' or 'vocational'), and as in Taylor's other examples of intrinsic orientations, it is intrinsic in the sense that it does not appeal to anyone outside the learner for recognition. Therefore, although it does not fit Taylor's description of a 'concern for personal growth and development', it has been classified as *Personal intrinsic* (PI).

Similarly, the concern to, 'set a good example to the children' does not immediately fit into any of Taylor's definitions. This has been classified as a *Personal extrinsic* (PE) reason because once again it is 'personal' rather than 'academic' or 'vocational', and it is extrinsic in that it depends on the response of the children to the learner's behaviour. This extends Taylor's definition which refers only to the desire to compensate for past failure in order to prove one's ability to others.

Taking into account these alterations to the category definitions, the data was then classified by both the researcher and an independent rater and an 82.6% level of agreement was achieved. The range of variation in learners' reasons for studying can now be plotted.

**Table 5.7: Learners' Orientations to study**

Learner No.	Type of 'Orientation'					(TOTAL)
	VE	VI	AI	PE	PI	
1	/	/				(2)
2	/	/		/	/	(4)
3	/	/	/			(3)
4	/				/	(2)
5	/			/	/	(3)
6	/			/	/	(3)
7	/	/				(2)
8		/			/	(2)
9	/		/	/	/	(4)
10	/	/	/		/	(4)
11	/	/				(2)
12	/	/				(2)
13	/	/				(2)
14	/	/			/	(3)
15	/	/				(2)
16	/	/				(2)
17	/			/	/	(3)
18	/	/				(2)
19	/					(1)
20	/	/				(2)
21	/	/				(2)
22	/	/				(2)
23	/	/				(2)

**Identification of primary reasons**

Once all the learners' reasons had been classified, a judgement was made for each learner as to which was his main type of reason for studying (ie. category, VE, VI etc.) and which was his next most important type of reason. Generally a learner's main reason was taken to be his first response to the question about reasons. It was felt, in this case, that primacy rather than frequency better reflected salience and importance of a construct to the learner. Exceptions to this occurred when the learner made it clear in further conversation that some other type of reason was his main reason. Similarly, his second most important type of reason was



taken to be the second type mentioned, unless again the learner made it clear that this was not his main secondary reason.

**Table 5.8: Primary and Secondary Orientation types**

Learner No.	1st	2nd	Learner No.	1st	2nd
1	VE	VI	13	VI	VE
2	PE	VE	14	VE	PI
3	AI	VE/VI	15	VE	VI
4	PI	VE	16	VE	VI
5	PI	VE	17	PI	VE
6	PI	PE	18	VE	VI
7	VE	VI	19	VE	
8	PI	VI	20	VE	VI
9	PI	PE	21	VI	VE
10	VE	VI	22	VE	VI
11	VI	VE	23	VE	VI
12	VE	VI			

The data reveals a diversity of technicians' reasons for studying. As anticipated, the reasons occurring most frequently were vocational; all learners at least mentioned a vocational reason. However, Taylor's categories highlight an important distinction between vocational reasons which lead to intrinsic interest and those which lead to an extrinsic interest in studying. In this group, 50% of learners had primarily extrinsic concerns such as promotion prospects and job prospects outside the company. Employers should be aware of learners' aspirations and the influence on these which they are able to wield. Another statistic which should concern an employer is that only 52% of learners felt that the course had helped them in their work. Regardless of the degree of actual improvement in job performance, this figure suggests a fairly low level of perceived relevance.

The use of Taylor's categorisation system with this group of learners appears to be viable. Most of the types of reasons identified amongst university students are represented in the data from technician learners.

The notable exceptions are the 'social' category and the 'academic-extrinsic' category. Understanding the absence of social reasons for undertaking an essentially distance learning course is not problematic. The absence of concern about academic achievement and qualifications for their own sake might simply reflect the vocational nature of the course. It might also reveal a concern for a specific application rather than the general value of qualifications. The great diversity of technician learners' reasons for study should be acknowledged and encouraged by employers as a valuable source of motivation.

## 2. How does X define learning in the context of the experimental learning task?

After completing the learning tasks subjects were asked:

"When I asked you to 'read the segment and *learn* it', what did you understand the word 'learn' to mean?"

The purpose of this question was to explore the meaning which the technicians had attached to the word 'learn' in the specific context of the experimental learning task. This would provide an indication of the way in which the learner had interpreted the demands of the task. In addition it would demonstrate an aspect of the conception of learning held by the individual, which could then be compared with reported behaviour in the same context or indeed conceptions of learning in other contexts.

Learners responded to the question by attempting to give a definition of learning as they had understood the term when it was used in the instructions of the experimental learning task (Interview schedule p3, appendix 3). Only comments which explicitly attempted to define learning within the context of the learning task were included in the analysis and

not simply descriptions of the learning process. The data was read and re-read to look for any patterns emerging, and the definitions seemed to fall into three distinct groups.

Memorise : Some learners use the word 'memorise', or seem to be referring to the storing of isolated units of information.

Eg. "Well, to have a quick look through and pick up as much information as you could in the time."

(No 13, p2a)

Knowledge : Other learners appear to be concerned with not only memorising, but also with acquiring a coherent picture, rather than isolated facts. (Use of the words 'knowledge' or 'information' might be an indication of this conception but should not be relied on if the rest of the quotation belies this interpretation.)

Eg. "To read and digest it so I'd got it in my head really. Getting everything together rather than have it in bits and pieces where it's explained there."

(No 11, p3)

Understanding: A number of learners used the word 'understanding' and/or indicated a concern to relate the information and make it meaningful.

Eg. "To understand the whole thing. A basic idea of the whole thing, not necessarily in great detail, the idea of what the thing is about."

(No 18, p4)

These descriptions which emerged from the data itself have been used as categories to classify the definition of learning held by each learner in the context of the learning task. A single unit of data for classification in this case is the response of one learner to the question about the meaning of the word 'learn'. In two cases where a learner's definition seemed to fall between two different categories or span across them, both

categories were noted with the most predominant one first. These categories were then used by the researcher and two independent raters and a 91% measure of agreement was attained.

The data falls into the categories in the following way:

**Table 5.9: Definition of 'learn' in the context of the learning task (by subject)**

<i>Subj. No.</i>	<i>Definition</i>	<i>Subj. No.</i>	<i>Definition</i>
1	Memorising	13	Memorising
2	Understanding	14	Memorising/Knowledge
3	Knowledge/Memorising	15	Memorising
4	Understanding	16	Memorising
5	Memorising	17	Memorising
6	Memorising	18	Understanding
7	Memorising	19	Memorising
8	Understanding	20	Memorising
9	Knowledge	21	Understanding
10	Understanding	22	Understanding
11	Knowledge	23	Memorising
12	Understanding		

**Table 5.10: Definition of 'learn' in the context of the learning task  
(by frequency of occurrence)**

<i>Definition</i>	<i>No. of subjects</i>
Memorising	12
Knowledge	3
Understanding	8
TOTAL	23

(NB. Where a subject has been allocated more than one category only the predominant category has been noted in this table)

It is clear that the groupings emerging from this set of data reflect some of the dimensions developed by other theorists which have already been considered. For example, the 'storing of isolated units of information' in the memorising category also forms part of an 'atomistic' approach as defined by Svensson (1977). Learner 19 could be said to be expressing an atomistic approach in his definition:

"Extracting the relevant facts from the information that was given. If say the extract was all fact, and no padding whatsoever, it would mean learning every single fact that was on the page."

(No 19, p7)

In contrast the approach of learner 9 could be described as 'holistic':

"Presumably you meant 'memorise it'. In memorising, you should have some means of knowing how you communicate with a computer, not just basically holding the facts."

(No 9, p5a)

The emphasis of Marton and Saljo on the comparison between a superficial (surface) and a meaning-oriented (deep) approach is reflected in this data.

Surface approach:

"Well, to have a quick look through and pick up  
as much information as you could in the time."  
(No 13, p2a)

Deep approach:

"Understand really - so that I understand what  
it meant rather than just trying to remember  
what was in it."  
(No 8, p3a)

A consideration of the complete set of learners responses reveals that the general tenor of the data is very similar to that reported of university students in previous studies.

**Table 5.11: Learners' attempts to define the word 'learn' in the context of the experimental learning task**

*Learner No.*

- 
- |   |   |
|---|---|
| 1 | " Well, I must admit, in this particular instance, to memorise, more or less." (p2a)  |
| 2 | " Understand it." (p6)  |
| 3 | " Well, digest it, as much information from the segment as I could.... to make sure I'd got it in my mind." (p3)  |
| 4 | "... what you've read in your mind, and now... do you understand it?" (p1a)   |
| 5 | " Well, that's an interesting question. Well, my interpretation of learning is to gather as much as I think is necessary from what I'm reading..." (p5) |
| 6 | " Well, memorise it basically." (p4a)   |

- 7 " Learn ? Memorise I suppose really. To me anyway." (p3)
- 8 " Understanding really - so that I understand what it meant rather than just trying to remember what was in it." (p3a)
- 9 " Presumably you meant 'memorise it'. In memorising, you should have some means of knowing how you communicate with a computer, not just basically holding the facts." (p5a)
- 10 " Make sure I fully understand it, not just flit through, make sure you absorb it." (p4)
- 11 " To read and digest it so I'd got it in my head really. Getting everything together rather than have it in bits and pieces where it's explained there." (p3)
- 12 " Well, take it in. That's why I read it through twice. First time you only glean the major points... but you get more depth the second time." (p3)
- 13 " Well, to have a quick look through and pick up as much information as you could in the time." (p2a)
- 14 " To be able to answer, to store that information in my brain so that when you asked me a question about it I could give you a satisfactory answer." (p3)
- 15 " Absorb the knowledge for just this purpose, this learning purpose at the moment." (p2a)
- 16 " To try and remember as much as possible." (p4)
- 17 " Well, memorise really. If ever I need to call back the information it's there. Something I try not to forget very easily." (p6)

- 18 " To understand the whole thing. A basic idea of the whole thing, not necessarily in great detail, the idea of what the thing is about." (p4)
- 19 " Extracting the relevant facts from the information that was given. If say the extract was all fact, and no padding whatsoever, it would mean learning every single fact that was on the page." (p7)
- 20 " To absorb the information and present it. In a sense I suppose, memorise it. I think, to be presented with something to learn, you don't learn by going over the subject thoroughly and get intimate with it. It's more a case of memorising it, not necessarily understanding it, and re-presenting the information as required." (p5)
- 21 " Learn what it's got there. Understand what the text is saying." (p3)
- 22 " To understand the information in there." (p5)
- 23 " Absorb it." (p3a)
- 

It is interesting to note the vocabulary used by these technicians to express their learning conceptions. The actual words 'memorise'/'remember', and 'understand' are quite common, appearing 7 and 8 times respectively. Sometimes the meaning of the two words is directly contrasted (eg. learners 20 and 8). In other examples the learner appears to be implying that the definition he is giving is just one of a number of interpretations of the word 'learn' (eg. learners 1, 5, 9, 10 & 15). Appreciating the learners' own vocabulary will be valuable in communicating with technicians in order to help them to learn more effectively.



### 3. On what does X focus his attention when studying the learning task?

One of the aims of this study was to explore the applicability of the work of Marton and Saljo (1976a) to this population of technician learners. In demonstrating a relationship between quality of learning outcome and learning process, Marton and Saljo developed dimensions of approaches to learning which distinguished between

"...the different aspects of the learning material on which the learner focuses."  
(Marton and Saljo, 1976a, p7)

Therefore, in the present study, the data was specifically addressed to identify the direction of the learner's focus of attention in tackling the learning task. Firstly, this made it possible to find out whether the same dimensions of deep and surface-level processing occurred in this population. Secondly, it provided dimensions which could then be related to quality of learning outcome, in line with the original Marton and Saljo study.

The inquiry was broadened from looking only at the way learners defined the word 'learn', to examining the way each learner tackled the experimental learning task. Through a process of reading and re-reading, all learners' comments which appeared to throw light on their focus of attention in tackling the learning task were identified. Some examples will illustrate the nature of the data itself:

"I go over it trying to pick out what I thought were the important facts."  
(No 22, p6)

"Well, I really concentrate. I pick specific bits which I think are important factors, and plant them in the back of my head."

(No 1, p2b)

"I read it, and go back to any bits I haven't understood."

(No 22, p5)

The data was studied carefully, looking for any patterns appearing within it. Again a distinction between 'memorising' and 'understanding' became evident. However, in this case, with more detailed information than simply learners' definitions of the word 'learn', it was possible to identify further differences within these groupings.

The 'Understanding' focus comprised three sub-groups:

Ui Sometimes learners seemed to be attending to the abstract message underlying the text, and in addition, very deliberately rejecting the details. For example learner 18 explained that his aim was "...to understand the whole thing. A basic idea of the whole thing, not necessarily in great detail, the idea of what the thing is about." (No 18, p4)

Uii In other examples learners were not so clear about rejecting the details, but nevertheless were focusing on the meaning or 'message' of the learning material. This focus could be characterised by a recognition that learning would involve relating the different aspects of information within the text. Learner 10 seems to be describing a process of actively searching for the meaning of the material. "I had to think about that diagram with the switches. Instead of just glancing over it and saying, 'that's the diagram for switches', I sat and worked out why. I sat and worked out how the numbers are added together to make up the units." (No 10, p3)

Uiii On other occasions the notion of 'understanding' appeared to reflect a focus on the understanding simply of individual sentences or isolated elements of the material. In the following example learner 14 is ensuring that he can understand the meaning of each paragraph as he goes along: "I read through the paragraph, and then if I look back at that paragraph and think about what I've read; if I can make sense of what I've read, then I go on to the next paragraph." (No 14, p3)

The 'Memorising' focus also fell into three sub-groups:

Mi Learners sometimes described themselves as trying to memorise when they were learning, but in explaining what aspects of the text they would memorise, made it clear that their focus was on the 'knowledge' conveyed by the material rather than isolated facts. They were concerned to understand the message, or link the facts together first, and then memorise them. Learner 11 exemplifies this phenomenon:

*Int.:* "And do you know how you decide that they are the main things (to memorise)?"

*Lnr.:* "I wouldn't say I know how, but as long as you can understand yourself, the reason for it - the reason why you put it into the computer... mainly it's for information."

(No 11, p3)

Mii The two final types of 'memorising' focus, Mii and Miii, both involve the memorising of isolated facts. In this category, Mii, learners focused on selecting *relevant* facts. Learner 15 reported that his concern in tackling the learning task was to 'absorb the knowledge'. When asked by the interviewer to explain how he set about this, he responded "Well I try to memorise it and try to pick out what I thought were the most important parts - the ones I thought you'd ask me about." (No 15, p2a)

Miii Finally it emerged from the data that sometimes learners might simply focus on memorising elements of the text without being selective and identifying 'relevant facts'. This distinction was highlighted by the following somewhat ambiguous description of focus of attention given by learner 19: "Extracting the relevant facts from the information that was given. If say the extract was all fact and no padding whatsoever, it would mean learning every single fact that was on the page." (No 19, p7). On the one hand this learner does refer to 'relevant facts', yet the phrase 'every fact on the page' implies a conception of the text as a disguised bundle of facts all of which are to be committed to memory.

The picture of dimensions of learners' responses emerging here is more complex than simply a distinction between a focus on the superficial aspects of the material as opposed to the meaning. Firstly, meaning is apparent at at least two levels. In sub-groups *Ui* and *Uii* the meaning aspired to is the overall message of the text. In sub-group *Uiii* the meaning involved is at the much simpler level of making sense of the sentences which form the text. Secondly, in being concerned with memorising, not all learners are focusing purely on the sign rather than the meaning. In sub-group *Mi* learners are trying to reach meaning first (even if only at a limited level), and *then* memorise. Using information processing terminology, these learners are transforming the information to some extent before storing it in long-term memory.

Having recognised these groupings, the data was then studied to identify the focus of attention indicated by each learner. No strict unit of data was imposed because there was no intention to use a quantitative measure to establish priority of focus. A note was made whenever a particular focus of attention was evident in the data from each learner. Quite commonly evidence of more than one type of focus of attention was apparent for the same learner.

**Table 5.12: Learners' focus of attention in tackling the learning task**

<i>Focus</i>	<i>Learner No.</i>	<i>Focus</i>	<i>Learner No.</i>
Ui	8, 18	Mi	9, 11, 20
Uii	3, 10, 11, 12, 2	Mii	1,2,4,5,6,7,8,13,14, 15,16,17,21,22,23
Uiii	4, 6, 14, 21, 22	Miii	19

In the above table, seven of the learners can be seen to focus their attention in the learning task both on memorising and understanding. This could indicate that the categories are not mutually exclusive, or that learners combine more than one focus in approaching the task. To explore the first possibility the relationship between the two sets of categories was examined. By shifting the positions of the two groups of categories in the table above, we can see that all but one of the learners' focus of attention falls into equivalent groups.

**Table 5.13: Equivalence of learners' focus of attention in tackling the learning task**

<i>Focus</i>	<i>Learner No.</i>	<i>Learner No.</i>	<i>Focus</i>
Ui	8, 18		
Uii	3, 10, 11, 12, 2	9, 11, 20	Mi
Uiii	4, 6, 14, 21, 22	1,2,4,5,6,7,8,13,14, 15,16,17,21,22,23	Mii
		19	Miii

Presenting the data in this way suggests that the categories represent different points on a spectrum of *Ui* through to *Miii*, where the sub-groups *Uii* and *Mi* are equivalent, and *Uiii* and *Mii* are also equivalent. Certainly the spread of the data is consistent with a meaningful spectrum, the majority of learners' focus being plotted in the middle with fewer occurrences towards either end. The most common focus is that of making sense of the text and then attempting to store that limited understanding. The hypothesis which equates these sub-groups is not unreasonable taking into account the descriptions of the sub-groups themselves. The sub-group *Uii* is concerned with 'focusing on the meaning or 'message' of the learning material,' and involves 'relating the different aspects of information within the text.' Similarly in taking an *Mi* focus a learner is 'concerned to understand the message, or link the facts together first, and then memorise them.' In both cases the attention is focused on the message of the text. In contrast, the emphasis of a *Uiii* focus is limited to 'the understanding simply of individual sentences or isolated elements of the material.' This emphasis is reflected in the *Mii* focus which is on '...the memorising of isolated facts.'

The only learner whose focus does not fit into the pattern is number 8. He is clearly aiming to understand the overall message (*Ui*) and responds to the question about definition of learning in the task by saying:

" 'Understanding' really - so that I understand what it meant rather than just trying to remember what was in it."

(No 8, p3a)

Having done this, he is also concerned to memorise the correct terminology (*Mii* type focus).

" There was a couple of times where it said 'pulse' and 'no pulse', and I always tend to think of these things as 'switch on' or 'off'. It was a matter of trying to think that in certain circumstances it is known as 'pulse' and 'no pulse'.

(No 8, p4a)

This individual appears to provide an example of the second interpretation of the data offered earlier, namely that some learners might combine more than one focus in attending to the experimental learning task. Perhaps he could be classified as a 'versatile learner' in Pask's terms (Pask, 1976), building up his understanding by both a 'top down' approach (ie. appreciating the general principles first), and 'bottom up' (ie. finding out about the details). Of course it is quite likely that other learners also take this approach even though it has not emerged so clearly from their interviews.

#### **4. What are X's general conceptions of learning?**

Questions 2 and 3 only refer to learning within the context of the learning task (learners were asked to explain what they had understood the instruction 'learn' to mean when given during the learning task and then, how they had tackled the task). It was apparent in reading learners' accounts of their broader experiences of learning that their general conceptions were more varied than the specific definitions which they had given. Such variation was also anticipated by our theoretical perspective which emphasises the influence of contextual factors. Therefore the data was then explored to find out about the full range of conceptions of learning held by each learner. In seeking answers to this question the following aspects of the data were taken into account. (In the examples aspects of the statement which characterise the type of statement illustrated are in italics; aspects of the statement indicating a conception of learning are underlined.)

- The learner's definitions of learning in the context of the learning task.

(For examples, see data from question 2, pp122-128)

- Objectives given for different study activities.  
(Eg. "*I go back and read that again and make sure I do understand it.*" No 18, p7)
- General statements describing the nature of the course.  
(Eg. "*...this one, there's so much parrot-fashion type learning.*" No 5, p4)
- Evaluative comments about the course from which criteria of judgement can be inferred.  
(Eg. "*Not difficult, because there's not so much to remember in that particular segment." No 16, p5a)*
- Descriptions of other learning experiences indicating a particular conception of learning.  
(Eg. "*There's some subjects I don't want to touch. I'm doing a Communication Studies course at the moment and err..... nothing is specific about it, it's a general one. There's no hard facts to absorb, so they mark you on your own thinking.... I don't like that style at all.*" No 9, p1a)
- Other direct statements about the nature of learning.  
(Eg. "*I felt I was stagnating, not learning anything. So I thought it was a good way of using my brain." No 14, p1)*

### **Elements of conceptions of learning**

Once again, no *a priori* assumptions were made about the content of the data. The raw data itself was scrutinised and the following different conceptions of learning were found within it:

1. Memorising isolated elements
2. Learning as a preparation for assessment



3. Memorising should follow understanding
4. Making sense of the text
5. Building up a coherent picture of the information
6. Putting the information into a wider context
7. Mental exercise
8. Working things out
9. Learning for enjoyment

Looking at conceptions of learning as reflected in the data as a whole revealed an extension on the range of qualitative variations in learners' definitions of learning within the context of the learning task. Variations of the 'memorising' and 'understanding' conceptions were apparent, and filled out by the broader data base. Also, however, some new dimensions appeared with elements that are tangential to the memorising to understanding spectrum. Some, for example, concerned the purpose of learning: for pure enjoyment (conception 9) or as an activity relevant only in the extent to which it prepares the student for assessments (conception 2). Conceptions 7 and 8 are closely related and concerned the exact nature of the mental activity of learning. These differences are significant because learners' conceptions of learning constitute the meanings which underlie their learning behaviour. By mapping the different conceptions which this population of learners hold it will be possible to compare these meanings with learners' intentions and their reported behaviour, to see why effective learning does not always occur.

The elements are listed and described below and illustrated with quotations of remarks made by the learners. Such quotations are given to provide concrete examples rather than definitive descriptions of categories being discussed. An individual learner's conception of learning tended to combine the elements discussed and so no attempt has been made at this stage to classify learners in terms of their conceptions of learning.

### *1. Memorising isolated elements*

Six learners saw learning as involving a process of 'acquiring' and 'storing' isolated units of information, sometimes referred to as 'facts'.

Int.: "What did you think the learning task involved basically?"

Lnr.: "Extracting the relevant facts from the information that was given."  
(No 19, p7)

This conception was characterised by a concern about the *quantity* to be learnt. For example, one learner remarked, when asked for his general reactions to the TS1 course,

"There seems to me - especially on this section - that there's a hell of a lot to learn... there's a hell of a lot you've got to remember."  
(No 16, p2)

This conception was also implied by the learning strategies sometimes adopted. Another learner describes his normal approach to studying a segment of the learning materials in this way:

"Well, I read it quite slowly and I try to pick the main points of each passage or section there, the points that I think are relevant to the learning of the passage or the memorising."  
(No 6, p4a)

(Also numbers 7, 13, and 18)

### *2. Learning as a preparation for assessment*

In eight cases, learning appeared to be understood as the activity necessary to prepare for some form of assessment. This was often linked with an intention to memorise, for example, in tackling the learning task.

"I tried to pick up what would be a question that someone was going to ask."

(No 6, p4a)

Another example is learner 7 who was actually explaining how he tackled the learning task, but expressed himself in a way that implied that the approach was more general:

"You can see a sentence and quite likely in the sentence there'll be a little bit that sounds more like a statement and I take those in and I think, you know, that comes up at the end in the questions."

(No 7, p3)

(Also numbers 9, 13, 14, 15, 16 and 23.)

### *3. Memorising should follow understanding*

Another eight learners qualified their use of the concept 'memorising' in learning by implying that it should only be applied to material which has already been understood. For example, this learner qualifies his definition of learning within the context of the experimental learning task:

"Presumably you meant 'memorise it'. In memorising you should have some means of knowing how you communicate with a computer not just basically holding the facts."

(No 9, p5a)

Some explicitly reject learning meaningless elements, an approach commonly referred to as 'parrot-fashion learning'. Learner 3 talks about the way he normally prefers to learn:

"I'd rather understand it than memorise little bits of it, with me it stays for longer."

(No 3, p7)

(Also see numbers 2, 8, 10, 11, 12, and 18)

#### *4. Making sense of the text*

Seven learners displayed a conception of learning based on

"Understand(ing) what the text is saying."

(No 21, p3)

(Extract from definition of learning in the context of the experimental learning task.)

The word 'understand' is used in a very specific sense of actually following the meaning of the text sentence by sentence. When describing his learning, learner 10 contrasts this approach with that of memorising.

"If I can read it like a story, sort of try and understand it as I'm going along..."

(No 10, p3)

(Also see numbers 2, 8, 14, 20 and 22)

#### *5. Building up a coherent picture of the information*

The word 'understanding' is used in another sense by eight of the learners, to refer to a more active process of building up a picture from the elements presented in the learning text. For example, one learner explains his aims in studying a segment of the learning materials:

"Getting everything together rather than to have it in bits and pieces where it's explained there..."

(No 11, p3)

This is associated with a desire to acquire 'an understanding' through learning (in contrast to the aim of fulfilling specific assessment requirements, as in conception number 2.) In the next example the learner is comparing his approach in the experimental learning task with his preferred approach in normal studying.

"If I was doing it on the course I'd want to know exactly how it worked."

(No 1, p2a)

Occasionally this sense of 'understanding' is contrasted with the activity of 'learning'; where the word 'learn' is used to refer to memorising. Learner 5 reported that he found 'purely learning' or 'parrot fashion-type learning' (p8) the most difficult aspect of the course, and further commented,

"I would much rather understand 'why' and 'wherefore' than to have to learn it."

(No 5, p8)

(Also see numbers 3, 8, 9, 18 and 22)

#### *6. Putting the information into a wider context*

Two of the learners expressed the expectation that their learning would apply to a wider context - particularly helping them in their understanding and performance at work - when discussing their aims in studying. For example:

" (The course) ...will help me understand why I'm doing things, not just do them."

(No 22, p2)

One carried this through into his conception of the learning process: He felt that real understanding had to go much further than simply an appreciation of the technical functioning of a piece of equipment.

"You can't just understand a dish and satellite, you've got to understand everything from the person in the call box in Newcastle to somebody in a flat in Sydney, Australia."

(No 17, p7)

### *7. Mental exercise*

Four learners saw studying first and foremost as a type of mental exercise, as these two learners indicated in giving their reasons for undertaking a course of study:

"To me studying is a thing that keeps your mind active."

(No 5, p1)

"...getting my mind working again."

(No 8, p2)

(See also numbers 14 and 17)

### *8. Working things out*

Five learners contrasted the learning experienced in this course with that involved in mathematics or physical science courses which they had studied. For example:

"... 'Physical Science' to me is great because I can get down and use formulas and work things out - it's great. This is just reading and it's very heavy."

(No 14, p1a)

(See also numbers 5, 16, 18 and 19)

### *9. Learning for enjoyment*

One learner made it clear when he explained the effect that poor promotion prospects were having on colleagues, that he saw learning as a leisure activity to be enjoyed for its own sake.

"(A lot of people say) ...'I'm not going to get promoted so I won't bother.' I think that's the wrong attitude. I enjoy courses. I enjoy reading and thinking."

(No 17, p1)

These dimensions of conception of learning emerged from data concerning technicians' approaches to learning. Two notable theorists, William Perry and Roger Saljo have also directly addressed themselves to the question of conceptions of learning, but in relation to university students. The relationships between these studies is worth examining. After extensive interviewing of students as they progressed through their university careers, Perry (1970) identified a number of stages describing both their intellectual and ethical development. He suggests that the starting point for most learners is to perceive knowledge and goodness together "...as quantitative accretions of discrete rightness to be collected by hard work and obedience." (p9). This position is represented in the present study by technicians who hold only conception 1, the memorising of isolated elements. Their conception of learning is characterised by a concern for the quantitative acquisition of facts. Perry then goes on to observe the development of learners' recognition of the relativistic nature of truth. In this study, such relativism is not apparent from the dimensions of learners' conceptions of learning. This could be because the nature of the interviews did not give learners scope to express their views on the nature of truth. However it also could be that without the benefit of a university course to develop their ideas, these technicians have not developed beyond Perry's most primitive stage. If this were the case, it might suggest that there is scope for exploring whether technician learners could be helped to develop their conception of learning to more sophisticated levels.

Saljo's study (1979b) also concerned university students, but deliberately attempted a mix of age and educational background. In the context of a more wide ranging interview, Saljo asked the question: 'What do you actually mean by learning?' He was able to classify learners' responses in terms of the following five categories:

**Table 5.14: Saljo's hierarchy of conceptions of learning**

---

**Conception 1:** *Learning as the increase of knowledge.* The main feature of this first category is its vagueness in the sense that what is given in the answers is merely a set of synonyms for the word learning.

**Conception 2:** *Learning as memorising...* The meaning of learning is to transfer units of information or pieces of knowledge, or what is commonly referred to simply as facts, from an external source, such as a teacher or a book, into the head.

**Conception 3:** *Learning as the acquisition of facts, procedures, etc., which can be retained and/or utilised in practice.* Compared to the previous conception... some facts, principles etc. are considered to be practically useful and/or possible to remember for a long period of time, and as a consequence of this they should be learned.

**Conception 4:** *Learning as the abstraction of meaning.* Compared to the previous two categories the distinctive characteristic of this conception is that the nature of what is learned is changed. Learning is no longer conceived of as an activity of reproducing, but instead as a process of abstracting meaning from what you read and hear... the reproductive nature of learning is replaced by a conception which emphasises that learning is a constructive activity. The learning material is not seen as containing ready-made knowledge to be memorised, but rather it provides the raw material or starting-point for learning.

**Conception 5:** *Learning as an interpretive process aimed at the understanding of reality.* This conception of learning is very similar to the previous one in the sense that the picture which is supplied in the descriptions concerning the nature of what is learning is very much the same. The reason for making a further distinction is that some subjects emphasise that an essential element of learning is that what you learn should help you interpret the reality in which you live.

---

(Saljo, 1979b, pp12-19)

These categories relate to those of the present study at a number of points. For example, element 1 in the present study shares with Saljo's conception 2 the emphasis on the memorising of isolated units of knowledge or 'facts'. Element 5 concerning the 'building up of a coherent picture' relates closely to conception 4 where learning is seen as the abstraction of meaning. Both specify the active nature of the process of



creating knowledge. Element 6 in the present study goes further in 'putting the information into a wider context'. Similarly Saljo's final category, conception 5, includes the awareness of the need to relate the content of the learning to the real world beyond. There appears to be a progression both in the perceived sophistication of the process of learning ('acquiring facts' to 'creating knowledge') and in its perceived relevance to the individual's own life. The most significant of Saljo's categories apparently not represented in the present data is conception 3: 'Learning as the acquisition of facts, procedures etc., which can be retained and/or utilised in practice.' This anomaly contravenes common sense which would predict that technicians in particular would be concerned with the practical application of their learning. In its place, the conception emerging from this data is the view that learning is primarily a preparation for assessment (element 2). Familiarity with the data as a whole suggests that assessment demands dominate the thinking of many of this group of learners, eclipsing the potential practical relevance of their learning. This highlights another possible inhibitor of effective learning which will be explored in the discussion of the data.

Both Perry and Saljo suggest that the different conceptions contribute to a developmental hierarchy through which learners progress as they become more sophisticated. In this data it was clear that nearly all of the learners (98%) indicate either explicitly or implicitly, an awareness of more than one meaning of learning. The average number of conceptions indicated in some way by each learner was 3.3, ranging from 1 to 6. Table 5.15 below presents the full range of conceptions of learning held by each learner in this data set.

**Table 5.15: Range of conceptions of learning indicated by each learner**

Learner Number	Conception Number:									TOTAL
	1	2	3	4	5	6	7	8	9	
1	✓		✓		✓					3
2	✓	✓	✓	✓						4
3	✓			✓		✓		/		4
4	✓									1
5	✓	✓			✓		✓	✓	✓	6
6	✓	✓		✓						3
7	✓	✓								2
8	✓	✓		✓	✓		✓	✓		6
9	✓								✓	2
10	✓		✓	✓	✓					4
11	✓				✓					2
12	✓			/						2
13	✓	✓								2
14	✓	✓		✓			✓	✓		5
15	✓	✓								2
16	✓	✓		✓				✓		4
17	✓		✓	✓		✓	✓		✓	6
18	/	✓			✓					3
19	✓							✓		2
20	✓	✓		✓						3
21	✓			✓	✓					3
22	✓	✓			✓			✓		4
23	✓	✓		✓						3

**Elements of conception of learning:**

- 1 Memorising isolated elements.
- 2 Learning as a preparation for assessment.
- 3 Memorising should follow understanding.
- 4 Making sense of the text.
- 5 Building up a coherent picture of the information.
- 6 Putting the information into a wider context.
- 7 Mental exercise.
- 8 Working things out.
- 9 Learning for enjoyment.

The range of conceptions held by each learner establishes at least that if learners do progress in their understandings of learning, they do not discard the old ideas as they develop the new. It is interesting to note that the one conception held by all learners - that of memorising isolated elements - is identified by both Perry and Saljo as being towards the base of the hierarchy. Therefore the data is consistent with the hypothesis that this conception also forms one of the most simple conceptions of learning held by these technician learners. Alternatively however, it might be a reflection of the nature of the demands of this particular course. More light should be thrown on this issue by the next question which examines learners' explanations of their approaches, to explore the conditions under which different conceptions of learning are indicated.

##### **5. Does X vary his approach in different learning situations?**

In recognising that learners have different conceptions of what learning is, and what it involves, the question is raised: do individual learners operationalise different conceptions in different situations? Theories proposing individual differences in approaches to learning (eg. Witkin, 1977; Pask, 1976) expect learners to adopt a characteristically similar approach in every situation. On the other hand, symbolic interactionists anticipate approaches varying according to context (Laurillard, 1979; Beaty, 1978). The origins and nature of variations in approach have important implications for any intervention to improve the effectiveness of learning. If variation stems from individuals, then intervention must be directed towards individuals. If variation results from a person/situation interaction, then change might be brought about through influencing both individual and situation. Therefore it was considered important in this study to examine the extent and nature of any variation in the ways particular learners approached different tasks. Attempts were

other words, to understand the meanings which learners attribute to their behaviour.

These questions were approached on two levels. Comparisons were made between learners' accounts of their experiences of the learning task, studying the course work, completing homework and preparing for the phase test; and also any other experiences of learning which individuals mentioned. At one level, note was made of variations in underlying conceptions of learning and focus of attention (as defined in previous questions) were noted. At another level the variation in study activity engaged in over the different tasks (eg. note-taking, rote-learning, practising problem-solving exercises). Finally, in reading through the transcripts, examples of learners' explanations of variations in their behaviour were noted.

#### **Variation in conception of learning**

Under question 4, a range of conceptions of learning evident within the data were described. The concern has then been to explore the extent to which an individual learner will operationalise a variety of different conceptions. Each transcript was read through completely and note was made wherever the learner employed one of the conceptions of learning outlined in question 4. Table 5.15 (p146) illustrated that most learners had indicated either implicitly or explicitly an awareness of a range of different meanings of learning.

Learners' accounts of their behaviour illuminate the conditions under which the various conceptions are manifested. It was apparent that sometimes more than one conception would be operationalised at the same time and in the completion of the same learning task. This occurred where different conceptions were seen as integral to the achievement of a single aim. For example, learner 17 sees understanding as integral to the task of remembering:

Int.: "Now you say that learning is 'remembering', do you look at it and think, 'Right, I've just got to remember everything'?"

Lnr.: "Not quite. You must understand. You can't just remember parrot-fashion... You've got to know why."

(No 17, p6/7)

Learner 16 also combines the conceptions of understanding and memorising. In describing his approach to normal study he complains,

"There's a hell of a lot to remember."

(No 16, p2)

and reports that,

"I spent a couple of nights a week on it and I got through it okay. I wouldn't say I can remember it all!"

(No 16, p4)

Here the emphasis is on memorising, but as this learner continues to expand on his approach it becomes clear that attempting to understand the material is also involved:

"Sometimes I read a paragraph through 2 or 3 times if I don't understand it."

(No 16, p6)

Quite commonly, where learners did use a number of different conceptions in explaining their approach, they differentiated between the different aspects of a single task. This was most apparent with the conception of learning as the memorising of isolated elements, which was employed for three distinct aspects of a learning task. The most popular was the learning of definitions and terms, for example, as used by the following learner in discussing his plans for preparing for the phase test:

"I did intend to write the definitions out and memorise them because I find that if I write

things like that down, then I memorise them better."

(No 12, p5)

(See also numbers 8, 11 and 20)

Others focused their memorising on the perceived demands of the tests. For example learner 9 explained that in learning he tried to pick out 'the important facts' and memorise them. When asked how he decided which were the important facts, he replied:

"Intuition actually. I've noticed during last year with these courses, there's certain things that stands out which looks like it's going to be important for the phase test."

(No 9, p5a)

Learners 7 and 15 also report a very similar strategy along with learner 12 who is very explicit about how certain isolated elements seem to 'stand out' in the text:

Int.: "Do you try to memorise anything?"

Lnr.: "Just the main one or two bits in the passage in dark letters. They seem to stand out so I tried to memorise those."

(No 12, p3/3a)

Finally, learner 3 illustrates another use of the conception of memorising isolated elements. He employs this when learning formulae.

Int.: "Are there any things that you do try to memorise?"

Lnr.: "Yes, formulas for working out frequency and period of cycle."

(No 3, p7)

In a number of cases learners explicitly associated different conceptions of learning with different contexts. For example learner 1 compares the context of the experimental learning task with that of normal studying and suggests that he would operationalise different conceptions of

learning in each. When asked what he had understood the word 'learn' to mean in the learning task instructions, he replied:

Lnr.: "Well I must admit, in this particular instance, to memorise more or less."

Int.: "Well, if there's some other instance, are there other ways you might sometimes think about it?"

Lnr.: "Well for instance, in that one it was purely a case of memory. If I was doing it on the course, I'd want to understand exactly how it worked."

Int.: "Why did you decide in this case to memorise?"

Lnr.: "Purely because I was going to be asked questions directly afterwards."

(No 1, p2a)

Other learners compared the context of the TS1 course with that of previous courses they had experienced. Learner 5 compares it with a mathematics course;

(In the trigonometry section of the mathematics course) "... Once you gather the principle behind it, it's all right. But this one (TS1) - there's so much parrot-fashion type learning, and that's a lot more difficult. I'd rather understand what I'm doing so that no matter what they throw at you, you can sus it out,"

(No 5, p4)

(See also numbers 14 and 18)

Learner 5 is quite clear that he would take different approaches to learning in different contexts.

" Well my interpretation of learning is to gather as much as I think is necessary from what I'm reading. In some cases that's geared to an exam, but I don't always look at it that way. If I read it, I read it to what I think is useful, what I want to get out of the subject matter."

(No 5, p5)

It is apparent then that these learners do utilise a variety of conceptions of learning both for different aspects of a learning task and for learning in different contexts. Where learners gave their rationale for adopting a particular approach, indications were sought as to why a conception was considered to be appropriate. Learners most commonly gave their reasons for memorising material, and as indicated by the quotation of learner 1 above, they considered memorising to be appropriate for material which was to be formally tested. Other examples are learner 2 who explained that he tried to memorise

"...What I thought was important.. the sort of thing I'd be tested on.. as I was reading it I thought, 'I'll pick out points I have to try and remember.'"

(No 2, p7)

and learner 14:

Int.: "Why did you try to memorise the table particularly?"

Lnr.: "You said, 'read through and learn what was in the piece of paper', so I thought you may well ask me a question about that."

(No 14, p3/3a)

(See also numbers 18 and 22)

Learner 17 explained why he considered it necessary to understand the broader context of the information covered in the learning materials;

"... it's everything and the rest of it you have to learn. I mean, how you put speech into different sorts of modes. Obviously you can't send the same speech down a pair of wires as you can down a laser - down a glass tube. Those sort of things they're, if you like, sideline knowledge, but you have to know that - or you have to understand that - before you can understand other things."

(No 17, p7)



Learners 10 and 22 indicate that they use a 'working things out' conception of learning when trying to understand certain types of materials.

"They didn't explain very clearly exactly what a harmonic is, and how to work out what they are... You've got to sit down and work it out - possibly go to other reference books."

(No 22, p4)

Learners' explanations of their rationale in approaching learning tasks were dominated by reference to assessments of various kinds, be it the immediate assessment of the experimental learning task or the formal assessment of the course itself. Learner 22 expresses this general concern:

"... when you know you've got to sit an exam you subconsciously must be looking at points that you think you'll be asked, and you'll always make sure that you know those..."

(No 22, p6)

Some learners showed not only a concern about assessments, but also that a detailed knowledge of the nature of the assessment influenced the conception of learning operationalised.

"I programme myself to look for things that I think are going to be asked in exams, as much as learning what it's about. It's possibly due to what I found on the last course, I was learning things, actually learning what it was talking about. But I found out that when I came into exams, they were asking little things about those things. So now I tend to look for the points which look relative to it all, you know, the key words if you like, and try and remember those things."

(No 18, p5)

This individual could be an example of a 'cue-conscious' learner as identified by Miller and Parlett in their work with undergraduates (Miller and Parlett, 1974). Miller and Parlett suggested that learners vary in the extent to which they are aware of the clues or 'cues' as to how to

succeed, provided by the learning environment. Learner 18 quoted above has clearly recognised that to succeed in the assessments used in these courses, it is more important to be able to remember isolated facts than to have an overall understanding. He has adjusted his approach accordingly. Two further learners in this sample demonstrated cue-consciousness, not in adopting a particular conception of learning, but in deciding which learning tasks to focus on:

"I was hoping to do all the homework this time. But you're not assessed on the homework on this course whereas you are on the other one I'm doing."

(No 13, p4a)

"You sit the exam and you've got to answer six out of twenty and you really need to answer three to pass it. So percentage-wise I could afford to discount things."

(No 23, p2)

It is clear that many learners do have a range of conceptions of learning (see table 5.15, p146) and report that they operationalise them in different situations. This favours an interactionist interpretation of the data. In particular, some of these learners appear to be concerned to adjust their conceptions according to the nature of assessments.

The next section examines the extent to which these adjustments in conception of learning are reflected in changes in study activity.

### **Variation in study activity**

On the whole, the actual study activities in which learners engaged varied very little across the different tasks. In 65% of the transcripts the evidence suggests that learners take basically the same approach to all tasks in the TS1 course (in most of the remaining data, the details of study activity are not clear enough to make a judgement). Many learners, such as number 6, slip into talking about their normal approach

to studying when being asked about their approach to tackling the learning task.

" Well I just read it quite slowly and I tried to pick the main points of each passage or section there was - the points that I think are quite relevant to the learning of the passage or section or the memorising - what was actually said. What I normally do; I read it slowly and then go back again. I try to pick them out as I go along."

(No 6, p4a)

This uniformity could perhaps be explained in part by the fact that it became apparent that there was very little variation in the sorts of tasks demanded of learners in the TS1 course. Also, because the learning task was designed to match normal study tasks as closely as possible for reasons of ecological validity, it did not provide a contrast with normal study tasks. It was not surprising therefore that learners' descriptions of their approach to the learning task and to normal study often merged together, and could not always be distinguished.

In some cases, however, learners made it clear that they used certain activities for study partly because they knew of no alternatives. For example learner 21 describes how he prepares for phase tests:

"I just keep reading over the material, like I did at school for 'O' levels. Just keep reading over the text. That's all you can do really."

(No 21, p5a)

Similarly learner 2 talks about studying the normal learning materials:

"The only thing you can do is sit at home and read it, and read it again until it makes sense."

(No 2, p4)

(See also numbers 3, 20 and 23)

At the learning activity level then, there is very little evidence of variation. This applies to variation between learners as well as within learners and between tasks. On the whole this could be explained by the homogeneity of tasks demanded of learners, but also there was evidence from some learners of a lack of awareness of alternative approaches.

One way in which learners do express variation in their approach across tasks is in terms of the amount of effort expended. 60% of learners explicitly commented that they would normally put more effort into studying a segment of the learning materials than they had for the learning task. This extra effort generally took the form of reading the segment through a greater number of times.

" This is probably not quite how I'd do it if I was with the learning package (ie. normal studying) because I'd have more time to read and digest.... Even a small passage as that, you have to cover two to three times so that you get the information to stick in your mind."

(No 20, p5 & 6)

" Not difficult... but I didn't have time. At home I'd read it over quite a few times."

(No 21, p3)

Similarly learners reported that in trying to prepare for the phase test they would read the materials over and over again to 'learn' them.

This lack of variety in study activity is inconsistent with the apparent range of conceptions of learning available to these technician learners. There are a number of possible explanations for this. It could be that although learners do alter their learning behaviour in response to different conceptions of learning, they are not able to express the subtlety of variation. Alternatively, it may be that learners are not able to translate changes in conception into altered behaviour. This would impair the effectiveness of their learning. Finally, it should be recognised that the range of conceptions of learning were drawn from technicians' comments about *all* their learning experiences, whereas the range of learning activities only applies to the experimental learning

task and the TS1 course itself. This suggests that this learning context in some way inhibits the use of variety.

#### 6. To what extent does X feel in control of his own learning?

This question was not anticipated by the research design. However differences in the extent to which learners perceive that they are in control of their own learning were apparent in the data collected about conceptions of learning, and also in learners' descriptions of their approaches to learning - in particular, the way they tackled difficulties. Therefore the data has been pooled so that the issue can be considered in its own right.

Differences in perception of control were apparent in learners' conceptions of the role of effort in learning achievement. This was most clear where success in learning was perceived to be due to circumstances beyond the individual's control. For example, learners 2 and 12 suggested that learning is more difficult for older people.

"As you get older you have to read it a few more times before it sinks in. You're not so agile mentally as you were when you were younger."

(No 12, p2)

Others referred to different levels of mental ability as determining your potential for success in learning (numbers 4, 14 and 18).

"You can draw a line between you're either brainy or not brainy. You're on one side or the other. Everyone knows their limit. I know I wouldn't pass these courses... I know damn well."

(No 4, p4)

In both these cases, lack of success in learning is attributed to a fixed characteristic of the learner, his age or an innate ability level respectively. Such characteristics are beyond the learner's control, and the implication is that the application of effort will only make a limited difference to learning performance.

This perception contrasts with that apparently demonstrated by those learners who respond to learning difficulties by applying more effort.

"If I found something exceptionally difficult, I would go over something until I had learnt enough from it."

(No 20, p6)

"I haven't been able to devote as much time as I would like to it. I hope to put in more effort towards the phase test."

(No 8, p2a)

"It depends on the individual. If I can't understand something, I wouldn't sit still and wait until I was completely lost. I would just say, 'Excuse me, can you explain that again?' "

(No 1, p6)

In each of the above examples the learner believes that he can improve his learning success by taking action of some sort.

The examples given are simply quotations of isolated comments made by learners and no claims are made that they truly represent the conceptions of those particular learners. However they do serve to highlight a possible difference in approach to learning. The difference seems to hinge on the perceived *locus of control* in learning. Learners who consider that learning achievement depends on their own efforts could be said to have an *internal locus of control* with regard to learning; they see themselves as having some measure of control over their learning. Those who attribute learning success to characteristics such as age or brain capacity, could be said to have an *external locus of control* with regard to learning, because these characteristics are beyond the control of the learner. Such differences in conception could be expected to have an influence on learning behaviour.

This proposed dichotomy appears to parallel the work of Dweck on children's theories of intelligence (1986). Dweck suggests that children commonly have one of two theories of intelligence, each of which has behavioural implications. Some children see intelligence as a fixed trait, and these children tend to look for situations in which their own intelligence will win a favourable judgement. In contrast children who see intelligence as a malleable quality look for opportunities to develop it. The data from the present study does not refer to learners' perceptions of intelligence but of learning achievement. However the parallel is quite striking with the 'fixed trait' view reflecting an external locus of control and the 'malleable quality' view reflecting an internal locus of control. The implication, therefore, is that learners with an internal locus of control will be much more likely to make an effort to improve the effectiveness of their learning than those with an external locus of control. The latter will blame any lack of success on circumstances.

#### Questions of Practical Interest

**7. Does X use any study techniques or strategies such as might be taught in a conventional study skills course or book?**

In order to answer this question all activities which learners reported to engage in for the purpose of learning were noted.

Learners' approaches were all very similar. The basic elements were that the learner would read a particular segment of materials through at least once, and then try to answer the self-assessment questions (SAQ's - a more detailed discussion of these under question 8). The segment would then be read through a number of further times until the learner was

satisfied that he could answer the SAQ's without referring to the text. Preparation for tests generally involved a repetition of this process with particular attention paid to segments which the learner had difficulty either with understanding or remembering.

*(a) Note-taking*

The use of note-taking was fairly limited (21% of learners) mainly because,

" Everything is written down and there didn't seem to be any point in writing notes..."  
(No 3, p10)

Those who did report taking notes (numbers 4, 13, 15, 16 and 19), did so in order to try and remember.

" You remember it better if you write it down."  
(No 15, p4a)

Similarly some learners would copy out diagrams to aid the learning process.

" Well, I'd try and actually do the drawing - copy it out. Then if it doesn't stick then, I'd copy it out again."  
(No 13, p7)

One learner (number 9) mentioned the particular note-taking technique of 'mind maps' taught by Tony Buzan (1974). He had used and appreciated it in another face-to-face course as an approach to making lecture notes. However he did not use it in this course because he felt that the written materials were adequate.

*(b) Self-testing*

A number of learners used various forms of self-testing. Learner 9 once again followed Tony Buzan's method of delayed self-testing.

" I fall in with a system of learning that I picked up some time ago: I read it, leave it for an hour, read it, leave for twenty-four hours.... just skipping through it. Read it



through again perhaps somewhere round a week.  
Usually enough information stays in there."  
(No 9, p8a)

Others avoid completing the SAQ's straight away and use them for delayed self-testing.

" I don't answer the questions straight away...  
I won't answer the questions properly until  
maybe next week... It's easy to read something  
then turn over the page and answer the  
question. That's fine until you come to do the  
exam isn't it?"

(No 17, p9)

*(c) Use of memorising techniques*

Only one learner reported using a particular memorising technique. Number 13 reported that,

" I always find if you can work some sort of  
ditty or something - like you do with the  
colour code for the cables - make yourself a  
little rhyme up... If you get yourself a  
particularly difficult part, you can remember it  
by that."

(No 13, p4)

*(d) Learning environment*

Only three learners mentioned their preferred learning environment when asked about approaches to study. All of them emphasised the importance of freedom from distractions.

" I'd put myself in a room on my own and read  
it through. I can't study when things are going  
on."

(No 7, p4)

Learner 2 is also aware of his own best time of day for learning.

" If you try and read something before you go  
to bed you're supposed to know it better  
straight off - doesn't work. It's better if I do  
it when I come in from work, before I go in to

eat or anything. I sit down... I shut myself off from everybody... No distraction that way."

(No 2, p9)

Learner 8 reports the opposite phenomenon. He finds that,

" I'm doing it at 11.30 at night, for some reason or other I seem to be receptive at that time of night."

(No 8, p6a)

He also emphasises the need to be free from distracting noises.

This dearth of variation, or even reflection on alternative approaches to learning suggest that these learners do lack conventional study skills. They might benefit from specific study skills training in the right context.

#### **8. Does X use the self-assessment questions (SAQ's), and if so, why?**

All learners were asked if they used the SAQ's, and so the answer to this question was noted. Any other comments on the SAQ's were also noted, with particular attention to why learners used them.

Without exception all learners reported that they did use the SAQ's. The majority of them (16 out of 23) used them as a means of testing their learning as they read through each segment of the materials.

" (It)... makes you look through the text to make sure... It makes you look through the text again if you're stuck on it (an SAQ)."

(No 10, p2)

Three learners (numbers 1, 12 and 20) felt that the questions would be more helpful if they were harder:

"I think if they were harder it wouldn't do

any harm. Nobody'd be penalised for getting it wrong - and on the other hand it's going to make you think harder. If you get it right, then so much the better. If you get it wrong, you can find out where you've got it wrong."

(No 1, p5)

Also some learners felt that it would be useful to have an extra set of questions that could be used during revision.

Three learners explicitly stated that they saw the SAQ's as an indication of the type of question likely to be asked in a phase test (numbers 1, 6 and 22).

#### **Ambiguity of questions**

Eight different learners spontaneously raised the issue of ambiguity of questions. This variously applied to SAQ's, homework and phase tests. Learner 2 for example criticised the wording of questions,

"... but sometimes the phrasing of the questions... I don't always see what they're getting at. I've sometimes answered SAQ's wrong because I don't know what they're getting at."

(No 2, p12)

Learner 17 (and also number 14) suggested that,

"... sometimes the way they word the questions - they try to make them so simple, you can't understand them."

(No 17, p3)

He also gives a clue as to why this issue was raised by so many learners. In at least one of the centres the problem of ambiguous questions had been discussed and the tutors had agreed with the learners' complaints.

The popularity of SAQ's suggests that they are, potentially, a powerful tool for communicating learning task demands. Perhaps it would be

advisable to provide a selection of questions graduating in difficulty to accommodate those learners who would like to be more stretched.

**9. Does X contact the tutor when experiencing difficulties?**

This issue arose spontaneously during a number of the first group of interviews. Subsequently interviewers were directed to ask learners whether they had or would, ever contact the tutor when experiencing difficulties. In analysing the data, answers to this question were taken into account, plus any other comments about telephoning tutors, and where the learners would generally turn for help.

No learners reported having telephoned the tutor during this TS1 course. In a number of cases the issue was not raised at all (numbers 6, 7, 9, 18 and 23). A further six learners reported that they had only just received the materials, and so had only just started to study. Some learners said that they would contact the tutor if they needed help (numbers 1, 3, 4, 12, 17 and 19). For example,

" Well, if I still couldn't answer the question,  
I would have to try and contact the course  
tutor."

(No 19, p12)

However the evidence is that even those learners who admit to having experienced problems with the course have not contacted the tutor, namely learners 1, 8, 16 and 21.

Various different reasons for not contacting the tutor were given. The most common reason was the inconvenience of actually getting in touch with the tutor (numbers 14, 16, 20 and 22). Tutors were only officially available at particular times of the week, but even where tutors had invited learners to contact them at home they were unwilling to do so.

" You have no direct contact with a tutor. You have contact, but you can't just pick up a phone and say "Fred..." and he's there. You've got to find the time when you're at home, or at work. You can call him at home, but you don't like to and so..."

(No 20, p9)

Some felt that a telephone call with a tutor wasn't a very effective way of solving problems anyway. Learner 22 suggested that the inevitable delay caused problems.

" If he's available on a Friday and you find a problem on Monday night, you've got to wait a long time before 'phoning him."

(No 22, p4)

Learner number 5 argued that

"... you can iron out a specific problem, but a concept you can't really get across. If you're in a class face-to-face you can iron out just what's behind it and why."

(No 5, p11)

Finally, underlying some of the learners' comments there seemed to be a hesitancy about contacting the tutor because it was seen as a sign of failure.

" The thing is, you've got to be confident yourself because you don't want to keep 'phoning or to run round asking everybody."

(No 2, p3)

Learner 1 talks about some of the problems he has experienced with the course. So far he has waited until the tutorial to sort them out and would only contact the tutor "... if I was really struggling." (No 1, p2). Yet even with serious problems on a previous course learner 8 reported that he didn't contact the tutor for help because he felt that the course was so much beyond him that he would have been wasting the tutor's time. Instead he simply dropped out of the course.

In case of difficulty learners were more likely to turn to colleagues for help (eg. numbers 5, 1, 12, 15 and 22).

" I've spoken to chaps at work about it if I haven't fully understood it. I've said, " Well could you explain this a little bit better...?" and they've explained it to me quite well."

(No 11, p5)

The response of these learners suggests that course providers cannot assume that they are supplying adequate tutorial support simply by giving learners a contact telephone number. It appears that tutors must be proactive in seeking out learners with difficulties.

## CHAPTER 6

### DISCUSSION: STUDY 1

In order to focus the discussion of the data arising from this study, a reference is made to the aims of the study and its parameters outlined at the end of chapter 3. Ultimately the aim of the study is to contribute to the development of an appropriate and useful model of effective learning at technician level in the Open Tech. To achieve this aim, the phenomenological paradigm has been employed, thus introducing (amongst others) the following guidelines to the research:

- The study should be concerned to provide explanations of the examples of learning behaviour occurring in the data.
- Explanations of learning behaviour will be sought in 'the ways in which this population of learners conceptualise learning', and 'the intentions which have prompted the individual to act'.
- The study should be seeking primarily to explain why the natural occurrence of effective learning behaviour is inhibited.

(Chapter 3, pp84-85)

Therefore the analysis will seek to explain the examples of learning behaviour occurring in the study, with a particular concern to explore why the natural occurrence of effective learning might be inhibited. This discussion will consider these learners' experiences of learning in terms

of the content of their learning, the ways in which they conceptualise learning (sometimes referred to as 'meanings'), and the intentions which underlie their learning behaviour.

### **Describing the content of learning**

The design of the study was modelled on the work of Marton and Saljo, in that subjects were required to complete a learning task and then describe their approach to the task. Marton and Saljo report finding a strong relationship between variation in learning approach and variation in quality of learning outcome. This data was analysed along the same dimensions to see whether a similar relationship was apparent.

Qualitative variations in learning outcome were observed, and a number of different ways of describing these variations were explored (Marton and Saljo's original method; essay-type marking system; SOLO taxonomy). Also, qualitative variations in approaches to learning were observed. The dimension which has been labelled 'focus of attention in task' was considered to be particularly close to Marton and Saljo's descriptions of 'deep-level' and 'surface-level' processing. However, when these dimensions are compared, the relationship between the outcome and approach is not as clear as in Marton and Saljo's study. This applies whatever the measure of learning outcome used.



**Table 6.1:** *Focus of attention in task x Quality of learning outcome, measure A (Marton & Saljo)*

	U1	Uii/Mi	Uiii/Mii	Miii
A	0	3	2	1
B	1	0	2	0
C	1	2	4	0
D	0	0	3	0
E	0	1	1	0
F	0	0	2	0
Median	B/C	B	C	A

**Table 6.2:** *Focus of attention in task x Quality of learning outcome, measure B (Essay)*

	U1	Uii/Mi	Uiii/Mii	Miii
Ave				
Score	6.25	6.25	5.2	9
'n'	2	6	14	1

**Table 6.3: Focus of attention in task x Quality of learning outcome, measure C (SOLO)**

	<i>U<sub>i</sub></i>	<i>U<sub>ii</sub>/M<sub>i</sub></i>	<i>U<sub>iii</sub>/M<sub>ii</sub></i>	<i>M<sub>iii</sub></i>
EA	1	1	1	0
R	0	1	5	1
MS	1	4	7	0
US	0	0	1	0
Median	R	MS	MS	R
'n'	2	6	14	1

**Table 6.4: Focus of attention in task x Quantity of learning**

<i>Score</i>	<i>U<sub>i</sub></i>	<i>U<sub>ii</sub>/M<sub>i</sub></i>	<i>U<sub>iii</sub>/M<sub>ii</sub></i>	<i>M<sub>iii</sub></i>	<i>Missing</i>
5	2	3	7	1	
4	0	3	4	0	
3	0	0	1	0	
Ave.	5	4.5	4.5	5	
'n'	2	6	1	1	2

No clear relationship between approach to learning and learning outcome emerges from these results. A number of reasons for this are proposed:

1. The numbers involved in this study are rather low for this sort of analysis. In consequence, the results have been skewed by one particular learner. This individual adopted a memorising focus, and yet

was able to produce a high quality learning outcome because he already knew all about computing (No 19). In fact the content of the learning task was not a good choice because a number of learners were interested in computers as a hobby. The design of the study was seriously flawed in not controlling for prior knowledge.

2. The wording of the learning task, 'Pick out the main points..' was designed to be content free. However this turned out to be counterproductive; the analysis of learners' interpretations of the task demands (see appendix 11) shows that many learners interpreted this as only requiring a listing of points. A deliberate policy of not probing for further explanations meant that the full extent of learners' understanding was not explored.
3. Learners' comments (see appendix 11) also show that they were unfamiliar with unstructured tasks. Some may well have simply been able to handle the new situation better than others. To use learners' explanations in this context as a measure of their understanding of the topic ignores the fact that the interview itself is a social interaction. Learners will be primarily concerned to respond in a way which they think appropriate to the situation. To display their knowledge of the topic is a secondary concern.
4. There were also problems with the quantitative test. The ceiling of the test was too low. It had been modelled on the normal SAQ's appearing in the materials, but this was a mistake because these are designed to be easy to encourage learners.

Therefore the learning outcome measures developed in this study do not provide very satisfactory indicators of effective learning. The discussion will focus instead on exploring the dimensions of these learners' approaches to learning. (Appendix 14 presents a table of learners' scores on all the categories developed in the study. The data is presented in order of diminishing quality of outcome. This is to expose any patterns emerging in the data which relate aspects of approaches to learning with learning outcome.)

**A consideration of the ways in which this population of learners  
conceptualise learning**

In the preceding data analysis three questions particularly relate to the ways in which these learners conceptualise learning:

*How does X (individual subject) define learning in the context of the experimental learning task?*

*On what does X focus his attention when studying the learning task?*

*What is X's general conception of learning?*

**(A) 'Memorising' to 'Understanding'**

A dominant theme emerging from the analysis is the distinction between 'memorising' conceptions and 'understanding' conceptions of learning. It appears in its simplest form where learners are attempting to define the meaning of the word 'learn' in the context of the experimental learning task. Three types of responses were identified: conceptions of learning as 'understanding', 'knowledge' acquisition, and the 'memorisation' of isolated elements.

In exploring learners' focus of attention in tackling the learning task, the distinctions emerge in greater detail. It has been suggested that rather than learners demonstrating three distinct categories of conception of learning, their responses can be seen as illustrating different points on a spectrum. At one end of the spectrum learners are focusing on the underlying message ('Uii', see p130), and at the other end their concern is with memorising isolated facts ('Mii' and 'Miii', see pp131-132).

This distinction is reminiscent of that highlighted by Marton and Saljo between levels of processing (1976a). In the present study the distinction is seen as one of *conceptions* of the learning process rather than the process itself, as the data does not directly access process. However it is accepted that when different conceptions of learning are operationalised different processes are implemented.

Marton and Saljo suggest that some learners adopt a 'deep approach' to learning whereby they focus on the task at 'message' or 'meaning' level. This phenomenon would fit the description of an 'understanding' conception. However for Marton and Saljo, at the opposite pole is the 'surface approach' in which learners focus on the superficial aspects of the text, ie. the 'sign' itself rather than what is signified (the message). In this study the 'memorising' focus is defined as 'involving the memorising of isolated facts.' The equivalence of these two definitions is not quite so clear; here the learner may not merely focus on the sign level. In fact in the definition 'Mii' (second from the memorising end of the spectrum) the learner is concerned to memorise *relevant* isolated elements. The learner must go beyond the sign to the meaning to some extent in order to decide what is relevant. This discrepancy between the two definitions highlights the ambiguity of the notion of 'meaningfulness' (or 'what is signified'). At the 'Mii' level described above, the learner may not be aiming to understand the author's message (as required in 'deep level processing'), but he still aims to gain some meaning from the text in order to distinguish between relevant and irrelevant facts.

In this case, the 'memorising' end of the spectrum is more clearly seen as a lack of concern to relate the material in the text. At the extreme 'Miii' level, the learner is aiming to memorise isolated facts without even selecting them to relate to the task. At the next level ('Mii'/'Uiii') the isolated facts are related to the task, but not to each other. Further up the spectrum the facts are related to form a coherent picture ('Mi'/'Uii'), and beyond that ('Ui') they are used to understand the overall message.

This exposition of the spectrum fits more closely with the descriptions introduced by Svensson when he re-analysed Marton and Saljo's original data (1977). To Svensson it appeared that some learners took an 'atomistic' approach, '.. focusing on specific comparisons, focusing on the parts of the text in sequence (rather than on the more important parts), memorising details and direct information...' (ibid.); whilst others took a holistic approach, '.. characterised by students' attempts to understand the overall meaning of the passage, to search for the author's intention, to relate the message to a wider context..' (ibid.). Ramsden, in exploring learners' approaches to learning in their normal studies, contrasts the extent to which learners aim to relate material both within itself and to a wider context (1979).

The analysis of learners' general conceptions of learning (question 4) continues the theme. Five of the nine different conceptualisations identified elaborate on the 'understanding' to 'memorising' spectrum. Two of the 'memorising' conceptions appear to vary in the relatedness of the object of the memorisation process: conception 1 involves memorising isolated elements; conception 3, memorising a message. The three 'understanding' conceptions represent different uses of the word 'understanding': from making sense of individual sentences (conception 4); through building up a coherent picture (conception 5); to relating the message to a wider context (conception 6). Again, a key element distinguishing the different conceptions is the degree to which the material should be related.

An interesting comparison can be made between this spectrum of conceptions of learning emerging from the present study, and the 'SOLO Taxonomy' developed by Biggs (1982). The SOLO Taxonomy was not designed to describe conceptions of learning, yet its descriptions reflect the distinctions identified between the conceptions of learning demonstrated by this population of learners.

**Table 6.5: The SOLO Taxonomy related to the 'Memorising' to 'Understanding' spectrum**

---

*Pre-structural.* The response has no logical relationship to the display, being based on inability to comprehend, tautology or idiosyncratic relevance.

*Miii* Learners focus on memorising elements of the text without being selective and identifying 'relevant' facts.

---

*Uni-structural.* The response contains one relevant item from the display, but misses others that might modify or contradict the response. There is a rapid closure that oversimplifies the issue.

+

*Multi-structural.* The response contains several relevant items, but only those that are consistent with the chosen conclusion are stated. Closure is selective and premature.

*Mii* Learners focus on memorising relevant, but isolated facts.

*Uiii* Learners focus on the understanding of individual sentences or isolated elements of the material.

*Conception 1* Memorising isolated elements.

*Conception 4* Making sense of the text.

---

*Relational.* Most or all of the relevant data are used, and conflicts resolved by the use of a relating concept that applies to the given context of the display, which leads to a firm conclusion.

*Mi* Learners focus on memorising the knowledge conveyed by the material rather than isolated facts.

*Uii* Learners focus on the meaning or 'message' of the materials and recognise that learning involves relating the different aspects of the information within the text.

*Ui* Learners attend to the abstract message underlying the text and deliberately reject the details.

*Conception 3* Memorising should follow understanding.

*Conception 5* Building up a coherent picture of the information.

---

*Extended Abstract.* The context is seen only as one instance of a general case. Questioning of basic assumptions, counter examples and new data are often given that did not form part of the original display. Consequently a firm closure is often seen to be inappropriate.

*Conception 6* Putting the information into a wider context.

---

Thus the SOLO taxonomy provides a framework within which to understand the different ways in which this population of learners conceptualise learning.

If this framework is accepted as appropriate, it also offers a clarification of the problem of ambiguity with regard to levels of meaningfulness. It has been argued that even at the 'memorisation' end of the spectrum, the learner does aspire to meaning (or, 'understanding what is signified'), if only to identify relevant isolated facts. Biggs suggests that the SOLO taxonomy should be seen as a cycle. A response (learning



outcome) which would be classified as 'uni-structural' in one context (at one level of abstraction) could also be classified as 'extended abstract' in another context (at a lower level of abstraction). Thus, for example, when a school pupil understands and grasps the implications of *Ohm's Law*, this learning outcome would be classified as at the 'extended abstract' level. However a physics lecturer would take *Ohm's Law* for granted as a basic building block of his thinking. His knowledge of it would only represent the equivalent to a 'uni-structural' learning outcome. Similarly it could be suggested that the concern to understand a single sentence of a text represents a very sophisticated learning outcome at one level (a beginners' language class?), whilst in a different academic context (an undergraduate lecture?), it simply represents the acquisition of an isolated unit of information.

The conclusion which must be drawn is that the sophistication of an individual's conception of learning can only be understood within a particular context. The pertinent aspect of context is the level of sophistication at which 'meaningfulness' is judged to be reached. This of course raises the problem: how is the judgement regarding appropriate 'message level' or 'meaningfulness' to be made? Marton and Saljo judge meaningfulness in terms of the message of the author, thus using the author's intentions as their criteria. There might, however, be other ways of deciding when a learner has gone beyond the sign. This suggestion will be picked up again and tackled in the next chapter which attempts to build a model of effective learning.

#### **(B) 'Active' versus 'Passive' approaches**

Conception 5, the 'building up of a coherent picture of the information' exemplifies an active conception of learning. The learner perceives learning to demand that he 'builds' an understanding, using the material available. This contrasts with a conception of learning as the passive absorption of ready-made knowledge, exemplified by conception 1, 'memorising isolated elements'. Laurillard (1978) reports a parallel phenomenon in her work with problem-solving tasks. She identifies that

some learners seek to draw their own conclusions and draw inferences in tackling learning problems.

Marton (1983) associates this type of distinction between active and passive learning with the deep-level and surface-level approaches to learning respectively. Active learning is characterised by a 'destructuring' and 'restructuring' of the learning material, whereas passive learning embodies a conception of knowledge as ready-made and complete. The work of van Rossum et al. (1985) however suggests that this is only one way of interpreting the distinction between active and passive learning. They asked students to explain what they meant by active and passive learning, and found differences in interpretation associated with the students' particular conception of learning. The distinction represented above was associated with the most sophisticated conceptions of learning (according to Saljo's hierarchy, 1979). At the other end of the spectrum, students saw active learning as simply intentional learning as compared with passive learning which was equated with either incidental learning or learning nothing at all.

In this study, there was also another way of interpreting active learning which is apparent in conceptions 7 (learning is a form of 'mental exercise') and 8 (learning involves 'working things out'). Here an analogy can be drawn with physical exercise. Physical exercise uses the muscles and by doing so keeps them fit and able to function well. In the same way, learning is seen as a form of mental exercise which, by using the brain, keeps it fit and able to perform well. It is the very activity of the brain which is the essence and the value of learning. Although this conception has face validity, it has not been discussed widely in other studies. Its relationship with the dimension discussed above is not clear. Of a total of thirteen learners who mentioned either conception 5 (active in the sense of restructuring information), or one or both of conceptions 7 and 8 (active in the sense of mental exercise), only three learners demonstrated holding both types of active conception. It may be that learners with a less sophisticated notion of activity in learning (as illustrated by van Rossum et al.) still perceive learning as exercising

the brain even though their form of active learning - intentional learning - would be seen as passive by others. Van Rossum et al. suggest that the relationship is developmental. The most sophisticated learners appreciate *both* types of learning, ie. active restructuring and passive absorption. The less sophisticated can only distinguish between different types of passive absorption, and use the term 'active' to label one of these types.

### **(C) 'Personal learning' versus 'Ritualised learning'**

Some of the ways in which learners conceptualised learning in this study implied varying degrees of 'personal involvement'. The meaning of 'personal involvement' used here is akin to that of Carl Rogers who talks about learning involving "... the whole person in both his feeling and cognitive aspects... *in the learning event.*" (1969, p5)

At one end of the spectrum is conception 2, 'learning as a preparation for assessment', which implies a conception of learning as a ritualised activity. In a ritual, the detailed activities only have significance because of the part they play within the rules governing the ritual. Similarly, if learning is purely geared towards preparing for an assessment, the learning activities have no value in their own right (and thus no personal significance) but are important only as a means of performing well in their assessment.

This conception of learning seems to be compatible with an extrinsic orientation to study. For example, with an exclusively 'vocational extrinsic' orientation to study, the content of the learning is seen as valuable only in that it enables the learner to jump the hurdle of passing vocational qualifications in order perhaps to gain promotion.

**Table 6.6:**      *The relationship between Vocational extrinsic (VE) orientations and 'Personal' versus 'Ritualistic' conceptions of learning*

<i>Learners with a mainly VE Orientation</i>	<i>'Ritualistic' conception</i>	<i>'Personal' conception</i>
1	x	/
7	/	x
10	x	/
12	x	x
13	/	x
14	/	x
15	/	x
16	/	x
18	/	/
19	x	x
20	/	x
22	/	/
23	/	x
	(69%)	(31%)

The table above shows that 69% of learners with a 'Vocational extrinsic' main orientation hold 'ritualistic' conceptions of learning as compared with only 31% holding 'personal' conceptions of learning. (These figures of course include some learners who recognise both conceptions, the categories are not mutually exclusive.)

The conceptions classified as involving 'personal learning' are numbers 5 and 6. In building up a coherent picture of the information (conception 5), the learner is striving for knowledge which is more personal than if he considered that knowledge could simply be 'picked up' or 'absorbed'. Conception 6 (putting the information into a wider context) recognises

the relevance of prior personal knowledge which may profitably be applied to the learning material. Bransford (1981) attributes this quality to effective learners in a study of school children. His study suggests that more effective learners can be distinguished from less effective learners by the fact that they use prior knowledge in attempting to learn new material. It must be acknowledged that neither conceptions 5 nor 6 imply such a personal conception of learning as that described by Rogers (ibid.).

It is interesting to note that in the present study learners themselves contrast this 'personal learning' (sometimes calling it 'understanding') with what they would call either 'pure learning' or 'parrot-fashion type learning' (eg. Learner 5, p8). Saljo reports the same phenomenon in a study of the development of conception of learning (1979). He found that some learners made a distinction between 'learning-for-life' and 'learning-in-school', or 'real' learning and 'rote' learning.

It would appear that just as ritualistic conceptions of learning are associated with extrinsic learning goals, so personal learning would be allied with intrinsic learning goals. Intrinsic learning goals involve some form of personal development. For example, with a 'Vocational intrinsic' goal the concern is to perform better at work, or a 'Personal intrinsic' where the concern is to develop as a person.

**Table 6.7: The relationship between 'Vocational intrinsic' (VI) and 'Personal intrinsic' (PI) orientations and 'Personal' versus 'Ritualised' conceptions of learning**

<i>Learners with mainly VI or PI Orientations</i>	<i>'Ritualistic' conceptions</i>	<i>'Personal' conceptions</i>
4 (PI)	x	x
5 (PI)	/	/
6 (PI)	/	x
8 (PI)	/	/
9 (PI)	x	x
11 (VI)	x	/
13 (VI)	/	x
17 (PI)	x	/
21 (VI)	x	/
	(44%)	(56%)

The table does not indicate a strong relationship between intrinsic goals and personal learning in the data. In fact, in the case of personal intrinsic orientations, more learners demonstrated ritualistic conceptions than personal conceptions of learning.

The fact that the relationship between extrinsic goals and ritualistic conceptions holds one way, but not the other way, ie. between intrinsic goals and personal learning conceptions, suggests that these learning conceptions should not be seen as simply equivalent though opposite ways of looking at learning. Other work, such as that already referred to by Saljo (ibid.) presents the distinction as part of a developmental progression. In Saljo's work it was the more sophisticated learners who could distinguish between 'learning-for-life' and 'learning-in-school'. Returning to the raw data in this study, it is apparent that at least one

of the three learners with a personal intrinsic orientation and yet holding a ritualistic conception of learning (No 5) demonstrates his awareness of this type of learning by *rejecting* it in the context. He argues that he does not like the TS1 course because

"There's so much parrot-fashion type learning,  
and that's a lot more difficult."

(No 5, p4)

Emerging from this discussion is a relationship between personal learning and ritualistic learning which parallels that proposed between active and passive learning. The hypothesis is that less sophisticated learners hold only a ritualistic conception of learning and more sophisticated learners recognise both personal and ritualistic types of learning.

It has been argued that these different conceptions are appropriate with different types of learning goals - either extrinsic or intrinsic - and therefore should be found to be associated empirically. However it must be recognised that although *logically*, for example, 'personal learning' conceptions should serve intrinsic goals, in practice learners' orientations and conceptions may not be in harmony with each other. This would then be one of the conditions inhibiting effective learning.

### **Towards an understanding of effective learning**

#### 1. The role of conceptions of learning

A number of different ways of conceptualising learning emerging from this study have been discussed. Some are compatible with each other and others are not. The conditions under which they will be operationalised depend partly on their relationship to the learner, and various options

have been suggested. Researchers such as William Perry (1970) associate particular conceptions of learning with developmental stages reached by an individual student. Thus the conceptions of learning operationalised by an individual are seen as characteristics of that individual. Marton and Svensson (1977) avoid attributing characteristics to individuals on philosophical grounds, arguing that the outcome of their researches can only constitute the description of a particular individual's behaviour in a particular situation. Nevertheless Marton associates certain conceptions with individual students, and expects consistency over time (Marton and Saljo, 1976a). Laurillard goes further and argues that the conception of learning operationalised by a learner is purely the product of that learner-situation interaction, and that the same learner will operationalise different conceptions of learning according to perceived task demands.

The philosophical assumptions underlying this research (see chapter 3) favour a learner-situation interaction interpretation of the data. However this interpretation must be tested against the evidence in the data itself. Question 5 of the data analysis addresses this issue asking, 'Does X vary in his approach in different learning situations?' The discussion then goes on to examine how learners account for the particular approaches which they adopt.

It was observed that overwhelmingly (there was only one exception) learners indicate that they are aware of more than one way of conceptualising learning (see table 5.15, p146). Sometimes learners would operationalise more than one conception in approaching a single learning task. For example a combination of an 'understanding' and 'memorising' conception was common in tackling the learning of the course materials. Learners felt that after understanding the meaning of the text it was also necessary to memorise certain details. Memorisation was seen as particularly appropriate for learning technical terms and formulae.

Also the evidence suggests that some learners apply different conceptions to different learning contexts. Quite commonly, learners perceived the TS1



course to require 'parrot-fashion learning', ie. the memorising of meaningless elements (conceptions 1 and 2). This was contrasted with the Mathematics and Physical Science courses which some individuals had pursued where the type of learning involved 'working things out' (conception 8).

Variation in context does not only occur between different courses. A number of learners distinguished between the demands of the experimental learning task during the interview, and those of normal studying. Where this occurred the more 'ritualised' and 'memorising' conceptions tended to be applied to the experimental learning task, whilst normal study was perceived to require 'understanding' and/or 'personal learning'.

These findings are compatible with Laurillard (1979) who reports that an analysis of learners' accounts of their approaches to study show that their approaches are context-dependent. Similarly, Ramsden (1979) concludes from a study comparing learners in different academic departments that '.. students' perceptions of their departments and their teachers... exert important influences on their approaches to learning.' (p411).

It appears that rather than each learner's approach being characterised by a particular conception of learning, generally learners have access to a range of conceptions which they operationalise as circumstances require. According to this interpretation it would follow that if circumstances have an important role in determining which conceptions of learning are appropriate, then in order to learn appropriately (and therefore, effectively) a learner needs to have access to a range of conceptions.

On this basis it could be hypothesised that the greater the range of conceptions to which a learner has access, the more versatile he is. The word 'versatile' has been used by Pask (1976) to describe learners who are able to use both a holistic and serialistic approach to learning in order to gain complete understanding. This might be an example of the phenomenon postulated.

Table 6.8 presents the relationship between the number of conceptions demonstrated by each learner, and the quality of learning achieved through the learning task.

**Table 6.8: Relationship between number of conceptions of learning held by each learner and their quality of learning outcome (measure A)**

Quality of learning outcome	Number of Conceptions					
	1	2	3	4	5	6
A (High -6)			2	1	2	1
B (5)		1		1		1
C (4)		2	3	1	1	
D (3)		1	2			
E (2)		1		1		
F (Low - 1)	1					1
Median value	F	C	C	B	C	B
Mean	1	3.6	4.3	4.2	5.3	4.0

Although table 6.8 does provide evidence of some relationship between the range of conceptions available to a learner and that learner's effectiveness, the relationship is not as clear as might be expected. In discussing the various conceptions and their relationships to one another, it was suggested that some conceptions might be seen as more sophisticated than others (see pages 177, 179 and 183). It is perhaps false to assume that all conceptions make an equivalent contribution to the effectiveness of learning.

Some supporting evidence for this conclusion can be found in a number of other studies conducted within this research paradigm. For example,

Morgan et al. (1981) observed that some learners were actively trying to improve their approach, but were 'locked into' a surface conception of learning. In addition both Marton and Saljo (1976b) and Biggs (1979) have conducted experiments in which they tried to manipulate learners' approaches. Both studies found that it was much more difficult to induce a true deep approach in learners originally adopting a surface approach than vice versa. The theory is also compatible with Perry's claim that conceptions of learning indicate different stages in a student's development.

This might suggest that surface or 'memorising' type conceptions are a more basic part of the learner's 'vocabulary' of conceptions. In this study all learners demonstrated the 'memorising' conception whilst only two displayed the most sophisticated 'understanding' conception (see table 5.15, p146). If 'understanding' conceptions are more sophisticated and therefore less common than 'memorising' conceptions, then it follows that most learners will be able to operationalise a 'memorising' conception if required but not all learners will have access to an 'understanding' conception. Even when they recognise that a change of approach is called for, some learners will not be able to respond appropriately.

Like the memorising conceptions (conceptions 1 and 3), ritualised conceptions (conception 2) and passive conceptions (conception 1) have been identified as less sophisticated than conceptions 4, 5 and 6 at the other ends of the various spectra. The following table only takes into account the number of more sophisticated conceptions demonstrated by each learner in order to avoid attributing the same value to both sophisticated and unsophisticated conceptions.

**Table 6.9:** *Relationship between number of sophisticated conceptions of learning (ie. nos. 4, 5 & 6) held by each learner and their quality of learning outcome (measure A)*

Quality of learning outcome	Number of Conceptions		
	0	1	2
A (High -6)	1	3	2
B (5)	1	1	1
C (4)	1	5	1
D (3)	1	1	1
E (2)	1	1	0
F (Low - 1)	1	1	0
Mean	3.6	4.0	4.8

The relationship between the number of conceptions and performance in the learning task is stronger in this table, particularly in the case of learners with two of the more sophisticated conceptions. These learners are more likely to demonstrate a higher than a lower quality of understanding.

What interpretation of conceptions of learning does the data therefore suggest? It appears that it is quite common for this population of learners to hold more than one conception of learning, and to operationalise different conceptions in different contexts. The range of conceptions could be seen as the contents of the 'toolkit' from which the learner can select in order to tackle a particular task. In addition it could be hypothesised that not all the tools are equally sophisticated, and there is a tendency for the more sophisticated conceptions to be built on the simpler ones (ie. memorising, ritualistic, or passive conceptions). As learners develop, they acquire and use some of the more sophisticated tools (ie. understanding, personal and active conceptions)

in addition to the simpler tools, where appropriate. The learner with the more sophisticated range is able to recognise when the simpler tools are inappropriate, whilst the learner with only simple tools must use them in all circumstances.

This analogy combines a developmental aspect with a learner-situation interaction interpretation. The range of conceptions held are a characteristic of a particular learner which can develop over time. However, the actual conception operationalised in a particular context depends not only on the range available to that individual, but also on that person's perception of task demands.

## 2. The role of intentions in learning

The data in this study includes learners' accounts of why they have operationalised particular conceptions of learning in particular circumstances. These accounts give an indication of how learners have perceived the task demands of the TS1 course.

It has been shown that learners' explanations are dominated by reference to the assessments involved in the TS1 course (see p145). As a result, various memorising conceptions are frequently perceived as appropriate in this context. The general concensus appears to be that the TS1 course demands memorisation of the information. Learner 18, for example, explains clearly how he adjusted his conception of learning through his experiences of a previous British Telecom course. Originally he had applied a conception involving a search for meaning; 'I was learning things, actually learning what it was talking about.' (No 18, p5). However he found that when he came to the exam, he could not answer the questions which appeared to him to be more concerned with the accurate recall of details. He now therefore operationalises a 'memorising' type conception of learning to the TS1 course and is concerned to gear his approach to the needs of the assessment ('ritualistic learning' rather than 'personal learning').

It appears, then, that in this study, learners quite commonly discerned the nature of task demands on the basis of course assessment criteria. Should it be concluded therefore that *effective learning* involves the operationalisation of learning conceptions appropriate to the nature of the assessment criteria? If this were so, then learner 18 would obviously be described as an effective learner. Yet the result of his assessment of task demands has been to adjust his approach to studying British Telecom courses from one based on an 'understanding' conception, to one based on a 'memorising' conception. As a result it must be acknowledged that the quality of his understanding of the materials is very likely to suffer. According to this reasoning it could be argued that his learning has become *less effective*.

In order to resolve this question it is necessary to establish a criterion of judgement. Whether or not quality of understanding is important will surely depend on the learner's intentions in tackling the task. Learners' intentions have been analysed under question 1: 'what reasons does X give for studying?' It was found that an adapted version of a categorisation system developed by Taylor et al. (1981) provided a useful way of describing learners' intentions or 'orientations'. These descriptions will therefore be used in the following discussion relating learners' intentions to their conceptions of learning.

It is argued that effective learning can only be defined in terms of the intentions which learner 18 has in studying the TS1 course. If his aim is purely to attain the highest marks possible in assessments, then it appears that by applying 'memorising' conception, he is most likely to achieve that aim. It would probably be acknowledged that the quality of his understanding would suffer, but if this is of no concern then he could be called an effective learner. If however learner 18's intentions were of a different nature, for example 'personal intrinsic', if he hoped to grow and develop personally through studying, then a 'memorising' conception would hinder his progress and so his learning would not be effective.

Some learners demonstrate personal aims, even within the context of an experimental learning task:

"Well, I just picked the important points. To me the important points were...  
.... That to me is as far as I want to go into computers at the moment."

(No 5, p6)

This learner is using personal criteria to decide his focus of attention, irrespective of the perceived assessment demands. If by chance these personal priorities do not match the assessment requirements then he is not likely to perform as well as he might in an assessment. Yet, if at the same time, the conceptions operationalised are appropriate to his own intentions then he has the best conditions under which to achieve those intentions. Common sense would suggest that this demonstrates effective learning, although this might not be reflected in the measures of performance used for assessment. Bugelski appears to be referring to the same phenomenon when he observes, 'Students have been known to remark, "I learned a lot in that course", even when they earned poor grades in tests. While such alleged values are difficult to measure objectively, they are probably the real core of the educational experience.' (1970, p196)

To summarise the argument so far, it is proposed that an effective learner is one who is able to adapt his approach to learning so that the conceptions operationalised are appropriate to the nature of the task and the learner's intentions in undertaking that task.

#### **What factors inhibit learners from displaying effective learning behaviour?**

The parameters of this research, restated at the beginning of this section, guide the discussion to consider why the natural occurrence of

effective learning behaviour is inhibited. The explanation of effective learning proposed above suggests a number of ways in which effective learning might be inhibited.

(1) Access to a range of conceptions

If learners are to adjust their approach according to the nature of the task and their intentions in undertaking it, and if approach in this context refers primarily to the underlying conception of learning operationalised, then learners must obviously have access to a range of conceptions of learning from which to choose.

However it has been demonstrated that quality of understanding does not directly correlate with the number of different conceptions to which a learner has access. The data suggests that some conceptions represent a more sophisticated developmental stage than others. It appears that learners with access to more sophisticated conceptions - certainly in the case of the 'memorising' to 'understanding' spectrum - generally also have access to less sophisticated ones.

Thus effective learning can be inhibited not only by the breadth of range of learning conceptions to which a learner has access, but also by the sophistication of the conceptions within it.

(2) Awareness of the learning process

It was reported of this data that in practice many learners do not vary their approaches to different learning situations (see question 5, p147). There is a group of learners for whom it appears to be self-evident that there *is* only one way of tackling learning. For example when describing the way he prepares for phase tests, learner 21 reports:

"I just keep reading over the material like I did at school for 'O' levels. Just keep reading over the text. That's all you can do really."

(No 21, p5a)



Such learners seem to have difficulty in responding to questions about the rationale for their approaches to learning.

Saljo appears to have uncovered a similar phenomenon in his study of the development of conceptions of learning referred to earlier (1979). He found that whilst some learners could reflect on and discuss their learning (where learning is 'thematised'), for others learning simply was not an object of reflection.

The work of Miller and Parlett (1974) on 'cue-consciousness' illustrates the learner who is aware of the learning process, for whom learning has become 'thematised'. It has already been pointed out that learners in this study displayed characteristics of 'cue-consciousness' (see p153). They are alert to clues in their environment which indicate how best to achieve good marks in assessments. In the light of the above account of effective learning, it appears that indeed the 'cue-conscious' student can be an example of an effective learner. The cue-conscious student reflects on his approach to learning and consciously adjusts it to the perceived demands of the situation. Similarly, both Biggs (1978) and Entwistle et al. (1979) have found in their respective extensive questionnaire studies that a 'strategic approach' is associated with academic success. Sternberg, representing the positivist research tradition, has also observed what he terms a 'strategy x stimulus (learning task)' interaction. He reports that certain taught learning strategies were systematically selectively used by subjects completing experimental learning tasks with varying task demands (1982).

However, even in the artificial context of the experiment, Sternberg goes on to observe that

"We would expect, however, that one's purpose, eg. reading the passages for comprehension versus reading the passages to learn new words, would, in effect redefine the task, and therefore would have an effect on which strategy is best."

(Sternberg, 1982, p167)

Therefore, returning to Miller and Parlett (ibid.), 'cue-conscious' behaviour or a strategic approach would only be effective if it were appropriate to the learner's intentions. For example, 'cue-conscious' behaviour would contribute to effective learning only if the learner had extrinsic orientations and was therefore concerned with passing exams as a means to an end, rather than intrinsically interested in the course content itself. Yet the model provided by the notion of 'cue-consciousness' can be widened to apply to different intentions. For example, the effective learner with 'vocational intrinsic' orientations would be alert to clues in his environment enabling him to make the most of the training potential of the learning opportunity. This might take the form of recognising his own particular weaknesses in job performance, and focusing on those parts of the course which relate to those aspects of his work. Thus, a strategic approach would be associated with effective learning so long as the learner was able to assess task demands in the light of his own intentions and adjust his operationalisation of learning conceptions appropriately.

Lack of awareness of the learning process thus appears to present a potential barrier to effective learning. This aspect of conception of learning must therefore be recognised as transcendent over the 'toolkit' of conceptions already postulated. Continuing with the same analogy; an awareness of the 'toolkit' is necessary before its contents (range of conceptions of learning) can be used effectively.

### (3) Locus of control in learning

A further factor which might inhibit effective learning was evident amongst this population of learners. It emerges from the analysis of the data regarding question 6: 'To what extent does X feel in control of his own learning?' This analysis demonstrated that some learners attribute success or failure in learning to factors *within* their control, such as the amount of effort they put into it. Others attribute success or failure to factors *outside* their own control, such as innate mental ability or age. This distinction was described as representing either an internal or an external 'locus of control' with respect to learning.

It follows that if a learner feels that the success of his learning lies beyond his control, then he is less likely to attempt to improve it by ensuring that the conceptions which he is operationalising match his intentions in learning. This implies that the effective learner must have an internal locus of control with regard to learning; he must believe that he has the power to improve the effectiveness of his own learning.

Entwistle (1987) discusses the same point in describing childrens' learning. He suggests that

'If pupils can be helped to move from external to internal attributions (of success and failure), if in other words they can be induced to take charge of their own learning, then they are more likely to increase the amount of effort they put into it.' (p139)

However, he also adds a word of caution which might apply to this population of technician learners:

'... This procedure seems to lead to beneficial results for some pupils, but not for others. There is, in fact, a danger in encouraging less able pupils to use internal attributions.' (p139)

The notion of locus of control introduces a further aspect of conception of learning which transcends the 'toolkit'. It is not part of the range of conceptions from which a selection is made in response to a particular situation. A learner's locus of control will influence the extent to which he believes he is able to improve his learning by adjusting his approach.

### Procedural steps to effective learning

A number of steps contributing to effective learning amongst this population of technician learners emerges from this discussion,

1. The learner is presented with a learning task.
2. The learner assesses the demands of the task taking into account both the nature of the task and his intentions in tackling it.
3. The learner selects appropriate conceptions of learning to operationalise, drawing on the range to which he has access.

These steps are illustrated by the following flow diagram which also postulates the further steps needed to complete the process of effective learning.

Figure 6.1: Procedural steps to effective learning in this population of technician learners

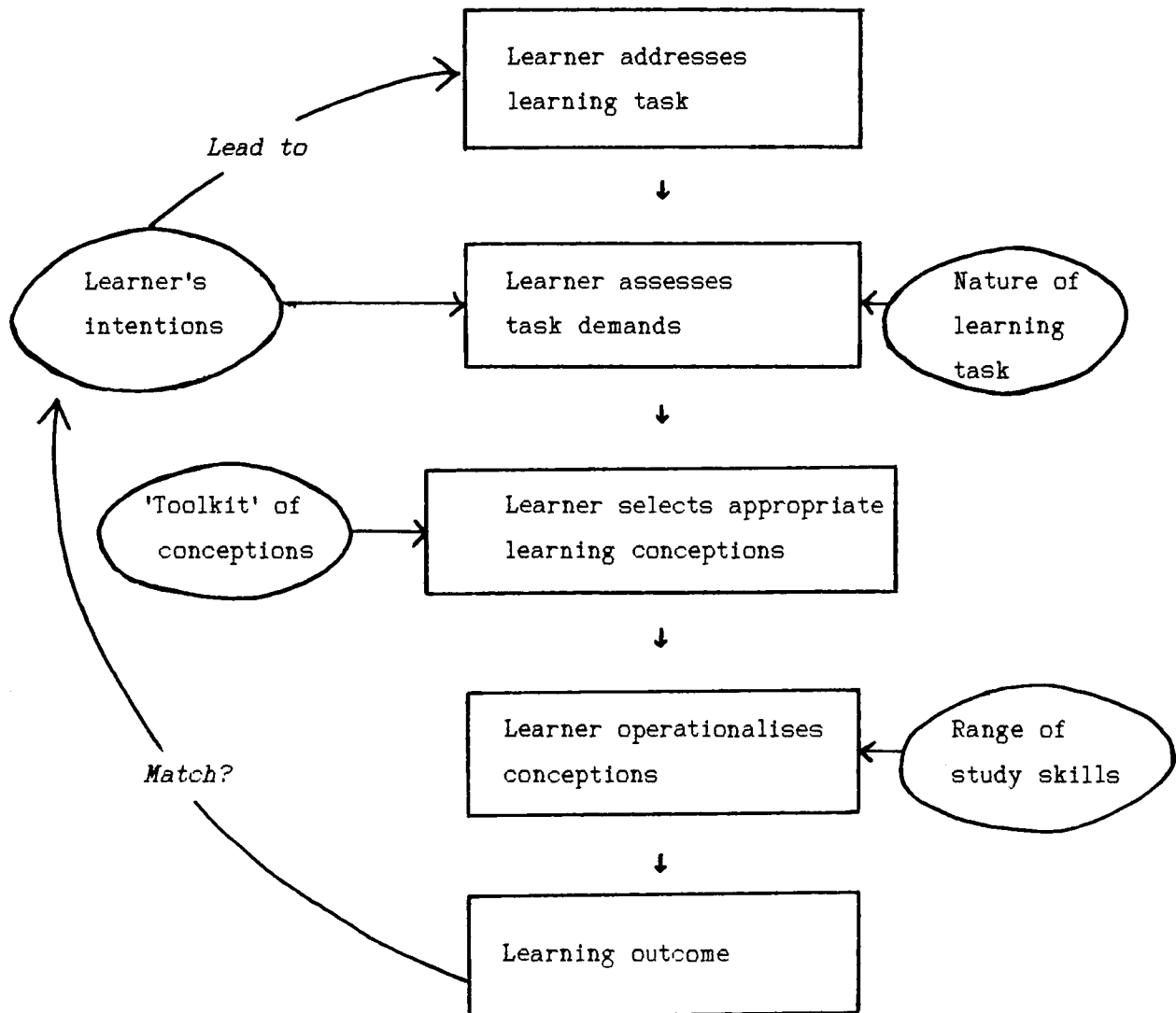

## CHAPTER 7

### INTRODUCING A MODEL OF MEANINGFUL LEARNING

Analysis of the data from the study of British Telecom technician learners suggests that for this group of learners, learning involves certain steps which have been outlined in the flow diagram presented at the end of the last chapter. The task now is to search for a model of learning which accounts for, and contributes to an understanding of, the nature of those steps.

The most promising source of an appropriate model appears to be the work of Marton and colleagues (1976a, 1976b, 1983) because their work shares the same research perspective as the current study; and the design of this study has been to some extent modelled on their approach. In this chapter Marton and Saljo's analysis of meaningful learning (Marton and Saljo, 1976a and b) will be examined and an amendment or extension to it suggested. The two alternatives will be discussed in terms of the underlying models of learning which they embody. Finally some of the theoretical implications of the amended model will be elaborated, suggesting a way ahead for the study.

### The Uni-dimensional Formulation

Marton and Saljo (ibid.) state that their "...studies have been concerned with meaningful learning in the true sense of the term." It is not unequivocally clear what they consider to be 'the true sense' of the term 'meaningful learning', and this question is dealt with more fully later. However at this stage, given their research perspective which involves understanding learning *through the learner's eyes* (Marton and Svensson, 1979), it would be reasonable to assume that they refer to learning which is 'meaningful to the learner'.

Based on the studies reported in the 1976a paper, Marton and Saljo identify that learners' approaches to studying are characterised by two distinct levels of processing.

"In the case of *surface-level processing* the student directs his attention towards learning the text itself (the sign)...In the case of *deep-level processing* on the other hand, the student is directed towards the intentional content of the learning material (what is signified)..."

(Marton & Saljo, ibid., p7)

These approaches are seen to be closely linked to learning outcome, with those learners adopting a deep approach gaining a higher quality of understanding than those adopting a surface approach. The criterion for identifying deep-level processing is that the learner's attention is directed towards the intentional content of the learning material, ie. the message which the author is trying to communicate. Thus Marton and Saljo seem to be suggesting that the route to high quality understanding - or meaningful learning - lies through an appreciation of the author's message.

Figure 7.1: The Deep/Surface Dichotomy as a Single Dimension

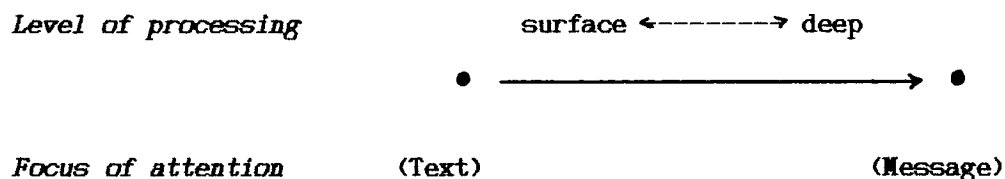

#### Introducing an Alternative Formulation

Marton and Saljo only claim to be describing these particular sets of data rather than presenting a general model of meaningful learning. However the formulation is very attractive in its simplicity and has been followed up by many researchers (Svensson, 1977; Laurillard, 1979; Ramsden, 1979; Entwistle, 1981). Before looking at some of these studies in more detail, the original formulation merits closer scrutiny.

If Marton and Saljo's analysis is conceptualised in the way illustrated by figure 7.1 above, the implication is that there is a single route to meaningful learning which depends on the learner focusing on what the text is about. However a common sense reflection belies this. Meaningful learning can result from interacting with the text in ways which either go well beyond the author's intentions, or even by-pass them altogether. For example:

1. The verses adorning the insides of greetings cards are often written at a very superficial level. However, when received in



particular circumstances they may take on a significance well beyond the author's, or even sender's, original intention.

2. Alternatively, in reading a text the learner may find meaning in a way totally unrelated to what the text itself is actually about. For example, Chaucer did not write his *Canterbury Tales* in order to convey a message about the use of old English. Yet a modern scholar might find his writing meaningful purely for the example of old English that it provides.

These examples suggest that the learner's intentions in reading the text determine the aspects of the text which the learner must focus on in order to learn meaningfully. Therefore attending to the author's message is essential *only* when that message is relevant to the learner's intention in reading a text. This is likely to hold true for example when an individual reads a discursive article for the purposes of academic study, which is the very context in which Marton and Saljo conducted the experimental work reported in their 1976 papers.

Thus the formulation of meaningful learning illustrated by figure 7.1 must be seen as context specific. The more fundamental principle underlying it is that meaningful learning arises out of the learner's interaction with the text - *not* necessarily at message level but - *in relation to his own learning intentions*. This suggests a multi-dimensional model of meaningful learning.

Figure 7.2: The Multi-Dimensional Model

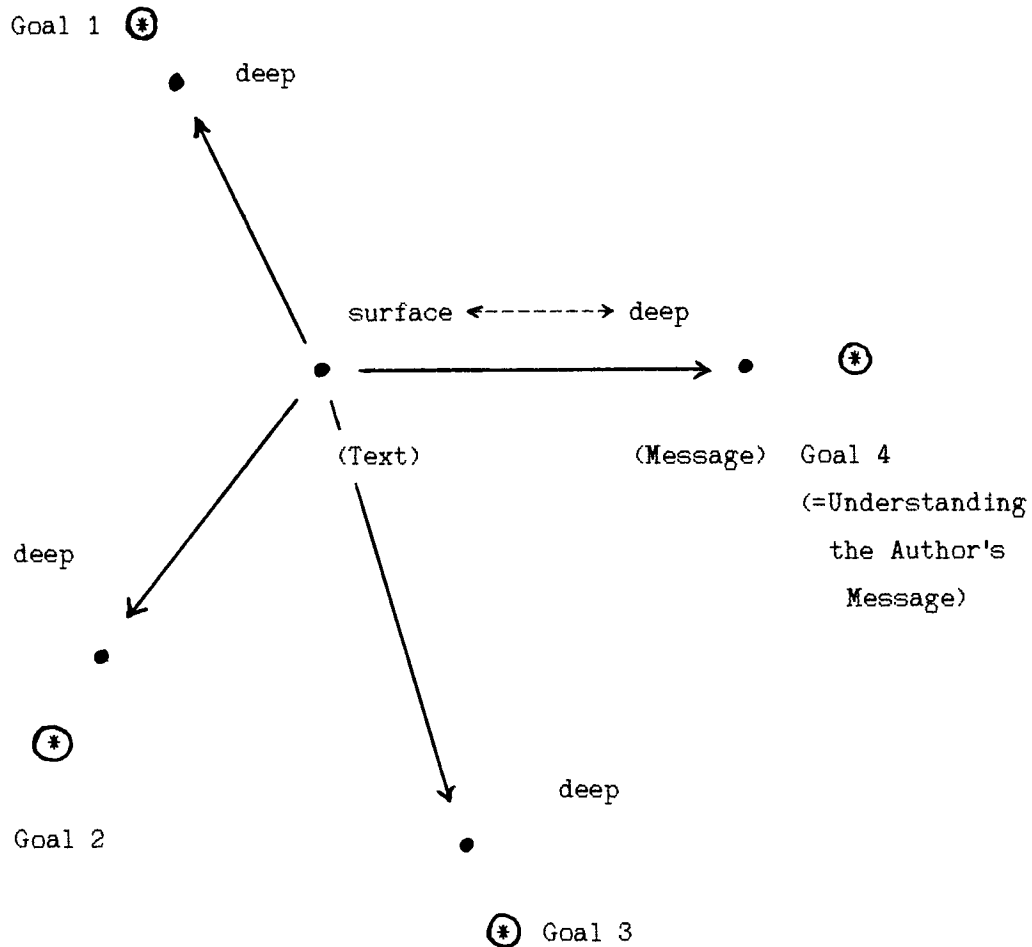

This formulation allows for as many routes to meaningful learning as there are learning intentions that a learner might have in studying a text. Very importantly, it indicates that a text does not have just *one* meaning, ie. the meaning intended by the author. A text, like a painting, can yield an infinite variety of meanings depending on what the reader brings to it and how he interacts with it.

### Discussion in the light of later work

Further studies using the same perspective as Marton and Saljo's original work have introduced features in line with the multi-dimensional model above. Of particular interest is research which has looked at studying in the normal context, thus broadening the range of possible intentions which influence the learner's approach.

Diana Laurillard's choice to study Science students (Laurillard, 1978) contrasts with the Education students used in most of Marton and Saljo's studies. She interviewed students at several different points during one academic year, asking them to bring along materials to the interview which they had been working on recently in their normal study. For these Science students, the learning tasks more commonly involved problem-solving than reading academic articles. Nevertheless, Laurillard identified a distinction in learners' approaches akin to the deep/surface dichotomy, although naturally they were characterised in a slightly different way.

Paul Ramsden has also gathered data which gives an insight into the deep/surface dichotomy in a wider context (Ramsden, 1979). He interviewed students about their normal studies, drawing on students from six different university and polytechnic departments covering a wide range of academic disciplines. Once again he has developed descriptions of students' approaches to learning which appear to relate closely to the original dichotomy.

In a paper in 1983 Marton draws on the work of both Laurillard and Ramsden in order to clarify and broaden the definitions of deep-level and surface-level processing. In the light of their findings Marton acknowledges that his original descriptions are simply examples of the dimension. Therefore he sets out to build more general descriptions of the two approaches using his own and also Laurillard's and Ramsden's data for instances.

Marton presents these descriptions as

"... a number of categories of description which were empirically found and which correspond to the qualitatively different ways in which students seem to experience learning tasks and learning situations."

(Marton, 1983, p292)

However, as he also points out in this paper,

"... any *description* of a certain phenomenon is relative to the *conception* of that phenomenon held by the one who describes it."

(Marton, *ibid.*, p291, my italics)

Therefore these broader categories of description will now be discussed, not to question their empirical basis, but to explore their underlying conception or model. It is particularly pertinent to this discussion to establish whether Marton's new formulation, taking into account - as it does - research from a wider context, now reflects the multi-dimensional model which has been proposed. The discussion will be concerned with the description of the deep-level approach, since it is in the definition of the deep approach that the conflict between the two formulations arises.

Marton's revised categories of description are summarised in the following table:

**Table 7.1: Subcategories of the deep approach**

---

(1) *Focusing on what the 'text' is about*

- Focusing on the author's intention (what it was all about, the conclusion, the point of the article).
- Keeping the end point in mind throughout the solution process.
- Having the phenomenon or the aspect of reality dealt with in the 'text' as the object of attention.

(2) *Relating*

- Relating the parts to each other or to the whole (within).
- Relating some parts of the 'text' to something outside it (between).
- Revealing the underlying structure of the text (beneath).

(3) *Being active*

- Finding out things (creative).
  - Drawing one's own conclusions, making inferences (logical).
  - Checking the logic of the author's line of argument (critical).
- 

(Marton, 1983, p293)

The description of the deep approach is now expanded into three subcategories.

"The three subcategories are seen as interrelated aspects of the kind of experience of learning we call deep approach. They are thought to be present in each case even if they are consciously focused on to various degrees."  
(Marton, *ibid.*, p293)

All three categories are essential to the definition and so each will be discussed in turn.

## 1. Focusing on what the 'text' is about

This subcategory reflects the emphasis of the original formulation, although Marton now acknowledges that not all learning tasks involve a text, therefore 'text', using inverted commas, denotes any type of learning task. In trying to establish whether it is still tied to the uni-dimensional model or whether it embraces the multi-dimensional model it is necessary to answer the question, 'what is the 'text' about - *for whom?*'. If the learner must focus on 'what the 'text' is about - for the author', then the uni-dimensional model is implied. If the learner must focus on 'what the 'text' is about - for the learner', then this implies the multi-dimensional model.

Marton elucidates the category with examples. The first is from his own work, and has already been discussed (pp198-199). The second is derived from Laurillard's work on problem-solving - deep-level processing involves 'keeping the end point in mind throughout the solution process.' Yet still the question remains, how is the end point defined? The end point of a problem-solving task could be the fulfilment of an intention determined by the learner. However it could also be simply the end point established by the teacher in designing the problem-solving task for 'educational purposes' (also determined by the teacher). The latter would be equivalent to the author's message and so be limited to the uni-dimensional model.

Marton's final example is derived from Ramsden's work and appears to break out of this problem by referring to 'the aspect of reality dealt with in the 'text' as the object of attention.' But on reflection it is clear that any text or task will refer to many different aspects of reality (even if only by analogy). Therefore to be compatible with the multi-dimensional model it would be necessary to focus on 'those aspects of reality referred to in the 'text' *which relate to the learner's own intentions* (as opposed to the author's).

It is clear that even this broader formulation of the deep approach is ambiguous about the crucial question raised by the multi-dimensional

model. It does not offer any criteria for establishing, 'what the 'text' is about'. It essential to identify the criterion for deciding 'what the 'text' is about' before it is possible to make any judgement on whether or not the learner is focusing on this.

Underlying this debate are assumptions about the location of meaning. In the original work Marton and Saljo appeared to assume that it is possible to talk about *the* meaning of a text. By this they meant 'the author's meaning', which could be said to be located within the text itself. In his more recent paper Marton acknowledges that "...what the text is about may certainly vary." (Marton, *ibid.*, p292). However, he then goes on to enumerate only variations caused by differences in context. The multi-dimensional model takes the issue further. As has been pointed out, it demands that a 'text' is seen as having an infinite variety of possible meanings, not only dependent on context, but also on what the learner brings to the 'text', including past experience and intentions for interacting with the 'text'. Thus the crucial difference is that meaning is not seen as located within the 'text' per se, nor even within the 'text' in a particular situation. Meaning arises out of the interaction of learner, 'text' and situation. Such a formulation is more compatible with the phenomenological perspective within which this research is firmly rooted (Marton & Svensson, 1979).

## **2. Relating**

Including the process of relating material as an essential component of meaningful learning is not contentious, as it is necessary to both models. The multi-dimensional model does however emphasise the importance of relating the 'text', not just to 'something outside it' (see Marton's second example), but specifically to the learner's own intentions. For example, it suggests that more meaningful learning would take place if the learner related the diagram of an engine in a textbook to his own car if his purpose was to try and mend his own car, than if his purpose was to learn about printing techniques for textbooks.

### 3. Being active

By introducing this subcategory Marton touches on an aspect of meaningful learning which is vital to the multi-dimensional model - the "...reliance on one's own capability to create knowledge." (Marton, *ibid.*, p292). Firstly, the notion of 'creating' knowledge implies that personal knowledge or 'meaning' is a unique product of a particular person/situation interaction. If meaning belonged to, and were located in the 'text', then it would have to be *transferred* rather than *created*.

Secondly, 'self reliance' involves some kind of individual purpose. Instances of this category for Marton include 'finding out things', 'drawing one's own conclusions and making inferences', and 'checking the logic of the author's line of argument' (see table 7.1). These activities only demonstrate genuine 'reliance on one's own capability to create knowledge' if the learner has executive control over them and is able to use them to fulfil his own purposes.

Again the differences seem to stem from the scope of the models underlying the two formulations. The instances which Marton lists describe the learner as active *within* the confines of the definition of the learning task. The interpretation demanded by the multi-dimensional formulation transcends the learning task and appeals to intentions of the learner which lie *beyond* it.

Empirical data supports the wider model. Morgan et al. report a study which involved interviewing Open University students about their normal approaches to learning (Morgan, Taylor and Gibbs, 1982). They found two distinct groups among those students who clearly took a deep approach to learning. Some learners displayed a 'personal involvement' whilst others took "...a deep approach but in a somewhat external, impersonal way or in a purely cognitive manner." (Morgan et al., *ibid.*, p110). They observe that the former group considered the learning material "in relation to their lives and themselves as individuals." (Morgan et al., *ibid.*, p109). This distinction between the two groups of learners appears to reflect very closely the distinction between the descriptions of meaningful learning



implied by the two formulations under discussion. Marton himself reported a similar phenomenon when he observed that some individuals conceptualise learning as "a process in which knowledge is made a part of oneself, it is the acquisition of (or a change in) an interpretive framework in terms of which the world around can be understood in a new and different way." (Marton, 1983, p296). He tentatively suggests that this should form a fourth subcategory of the deep approach.

#### **Summary of the Key Differences between the Two Formulations**

In this paper, a multi-dimensional model of meaningful learning has been proposed. The model has emerged out of a dissatisfaction with a uni-dimensional formulation of Marton and Saljo's qualitative descriptions of meaningful learning (Marton and Saljo, 1976). The alternative model has been elaborated mainly in relation to this uni-dimensional formulation. To complete this part of the chapter an attempt will be made to summarise the key differences in the assumptions about learning involved in the two formulations.

It has been suggested that the work of Marton and colleagues (1976a, 1976b, 1983) depends on a model of learning which judges quality of learning outcome in terms of the author's or educator's intentions (or message). The model describes the process of learning in equivalent terms. A distinction is made between a process of 'focusing on the author's or educator's intentions' (deep-level processing); and a process of 'focusing on the superficial aspects of a text or learning task' (surface-level processing).

The multi-dimensional formulation differs both in the way that quality of learning outcome is *judged*, and in the way that process of learning is *described*. High quality learning outcome, or 'meaningful learning', is not

judged in terms of proximity to the author's intention, but proximity to the learner's intention. Process of learning cannot however be described in exactly equivalent terms. It will be argued that when engaging in learning, learners could always be said to be pursuing their own intentions in some sense (if a learner had no reason whatsoever to engage in a learning task, then quite simply, he would not engage in that task). Therefore the distinction is not drawn between whether the learner is pursuing his own intentions or not. The process of learning is described in terms of whether or not the learner's intentions directly concern learning the content of the learning task, or whether the learning is seen simply as a means to some other end.

Underlying these variations in judgement and description is a conceptual difference concerning the location of meaning within a learning task. The uni-dimensional model assumes that the text (or learning task of whatever nature) has a specific meaning which is intended by either the author (as in a text), or educator specifying the learning task (eg. a scientific problem solving task for educational purposes). Successful meaningful learning takes place when the learner is able to appreciate that message or meaning which the author or educator intended. Thus, in essence, the formulation depends on the notion of communication - communication of the author or educator's intentions (message) to the learner.

In contrast, the multi-dimensional model gives the learner's intentions priority. It accepts that authors and educators have intentions in producing texts or learning tasks. However it suggests that meaningful learning takes place when the learner interacts with the learning task in pursuit of his own learning intentions. This ultimately depends on a problem solving model of learning rather than a communication model.

## CHAPTER 8

### ELABORATING THE MODEL

#### What is 'Meaningful' learning?

According to the description of the model in the previous section, '...meaningful learning takes place when the learner interacts with the learning task in pursuit of his own learning intentions' (p210). What implications does this definition have for the characteristics of meaningful learning?

Most importantly this model of meaningful learning implies learner autonomy. If the learner is pursuing his own intentions in tackling a learning task, then his behaviour is self-directed and not initiated by the intentions of others external to the learner. Not only is meaningful learning driven (or motivated) from within, but also it can only be evaluated from within. The learner's own learning intentions will derive from perceived or 'felt' needs. This means that only the learner himself can judge whether the needs are being met, whether the intentions are fulfilled. Such a judgement is essentially private and is very likely to involve an emotional response as a felt need is met. Therefore it can further be deduced that meaningful learning involves the learner both cognitively and affectively.

Many of these qualities have been identified by Carl Rogers as describing a particular type of learning. He outlines 'significant' or 'experiential' learning in the following way:

*"It has a quality of personal involvement - the whole person in both his feeling and cognitive aspects being in the learning event. It is self-initiated. Even when the impetus or stimulus comes from outside, the sense of discovery, of reaching out, of grasping or comprehending comes from within. It is pervasive. It makes a difference in the behaviour, the attitudes, perhaps even the personality of the learner. It is evaluated by the learner. He knows whether it is meeting his need, whether it illuminates the dark areas which he is experiencing. The locus of evaluation, we might say, resides definitely in the learner. Its essence is meaning. When such learning takes place, the element of meaning to the learner is built into the whole experience."*

(Rogers, 1969, p5 original italics)

This description further elaborates the notion of meaningful learning by acknowledging that such personally involved learning is likely to lead not only to the acquisition of knowledge or skill, but also to changes in attitude and perhaps even personality of the learner.

Bugelski (1970) explores the role of emotion in learning, and suggests that successful teaching can be associated with emotional conditioning. He argues that good teachers are effective because they create conditioning in which learners associate 'good feelings' with their subject matter. Such an analysis can be understood in terms of the multi-dimensional model of meaningful learning. If learning is actually meeting a learner's felt needs then it will be emotionally rewarding. As a result the learner will associate positive feelings with that learning experience, and according to Bugelski, become conditioned to expect rewards from engaging in similar learning tasks. Bugelski further suggests that the outcome of such conditioning is apparent in "...a favourable attitude toward the material ...the student is encouraged to pursue the matter further ...to read more, discuss more." (ibid., p195).

These qualities of increased interest and willingness to apply effort should therefore also be associated with meaningful learning.

To summarise, the qualities so far associated with meaningful learning

are:

- learner autonomy
- self-initiated learning
- self-directed learning
- self-evaluated learning
- high levels of interest in the learning
- increased willingness to apply effort
- learner involved both cognitively and affectively
- positive affect
- likely to lead to changes in knowledge, skill, attitude and perhaps even personality of the learner

#### **When does meaningful learning occur?**

The definition under consideration quite clearly states that '... meaningful learning takes place when the learner interacts with a learning task in pursuit of his own learning intentions' (p210). In introducing this definition the emphasis has been on the shift of focus from the author's intention to the learner's intention, and the recognition that learners' intentions might take very divergent directions. It is also important to acknowledge that an individual learner is likely to be pursuing more than one specific intention at any one time. This does not present a problem for the model because the greater the variety of intentions fulfilled through the learning task, the richer the resulting meaningful learning.

It might also be argued that learners may change their intentions during the process of learning. In fact it is a very legitimate aspect of the

educational process, that learners' goals and aspirations will change and develop as a result of learning. The multi-dimensional model can absorb the implications of this naturally occurring situation. It would mean, for example, that a learner can learn a new meaning from an old text or task as his intentions change and develop. This highlights the fact that the multi-dimensional model represents what is happening in the learning process *at any one time*. Meaningful learning will occur when the learner derives meaning from the text or task which helps to fulfil his intentions *at that particular time*.

Another example illustrating the immediacy of the multi-dimensional model is that of remembered information. Information might be remembered for one reason and then become relevant and lead to meaningful learning for a totally different reason on another occasion. In this case, the new meaningful learning would be said to take place at the later time, when the meaning enabled the learner to fulfil the new intention.

In what learning situations does meaningful learning *not* occur?

Meaningful learning does not occur when the learner engages in a learning task purely as a means to some further end (ie. for extrinsic reasons) rather than in response to his own felt learning needs (ie. for intrinsic reasons). This is likely to be manifested when:

1. A learner interacts with a task in pursuit of his own non-learning intentions
2. A learner interacts with a task in pursuit of externally imposed learning objectives, which might coincide with, be unrelated to, or in conflict with the fulfilment of his own perceived learning needs

1. *A learner interacts with a task in pursuit of his own non-learning intentions*

Learners will not always be motivated to undertake a learning task by a learning intention. For example, a schoolchild may be set the homework of reading a chapter of a textbook which he has no intrinsic interest in reading. In this situation there is no learning intention because the task does not relate to any learning need perceived by the child. The same child is asked to help with the washing-up, but manages to avoid it by arguing that the the homework needs to be done and going away and reading the book. Here the intention of the child was not in any sense to *learn* through reading the book. The intention was a non-learning intention, namely to avoid helping with an unpleasant task. Yet it cannot be denied that the learning task has been successfully used to fulfil the child's intentions of avoiding the washing-up. Should it therefore be argued that as a result, meaningful learning had *necessarily* taken place?

There is no necessity to conclude that meaningful learning in the sense discussed so far has occurred, ie. that the child has derived meaning from the text which has helped to fulfil that child's intentions. But another form of meaningful learning probably has occurred - the child has learnt an effective strategy for avoiding the washing-up. This example illustrates the fact that where extrinsic goals are pursued then meaningful learning using the content of the learning task will not necessarily occur. The meaningful learning that *will* occur will be linked closely to the intention rather than the nature of the text or task. The underlying principle to emerge from this discussion is that meaningful learning will always be associated with what is of intrinsic interest. This may be the content of the learning task itself, or, as in the example under discussion, some other problem area such as the avoidance of the washing-up.

*2. A learner interacts with a task in pursuit of externally imposed learning objectives*

Externally imposed objectives might coincide with learners' objectives, they might be unrelated, or they might conflict. Each of these conditions will be considered in turn in relation to their implications for meaningful learning.

*2a. Where a learner's intentions and externally imposed objectives coincide*

If a learner were pursuing his own intentions in a learning task and these happened to coincide with certain externally imposed objectives, this would provide the optimal conditions for those externally imposed objectives to be achieved. Meaningful learning would occur because the learner would be pursuing his own intentions, and the fact that these intentions coincided with externally imposed objectives would not detract from the meaningful learning in any way. The learning would still be autonomous - both self-initiated and self-evaluated.

The achievement of the externally imposed objectives would be enhanced because the qualities of meaningful learning (ie. increased personal involvement and interest, and the likelihood of behavioural and attitude change etc.), would not only be associated with the learner's intentions but also with the external objectives. An example of this might be where both trainee and employer recognise that the trainee needs to improve his fault diagnosis skills. If the trainee then pursues his training in accordance with this intention, his entire effort and interest will be directed towards the same concerns as the employer. Under such conditions he is more likely to achieve the objectives of the employer than if his own intentions were different.

It is interesting to note that a number of researchers, including notably Entwistle and Ramsden (1983), and Laurillard (1984) have observed that in academic learning, intrinsic motivation is closely associated with the deep-level approach. It would make sense that in an academic context, if



the student is intrinsically interested in a particular topic being studied, then the pursuit of the author's message (deep approach) is likely to fulfil that learner's intentions and lead to meaningful learning (according to the multi-dimensional as well as the uni-dimensional model). This provides a further example of where the learner's and the externally imposed (educator's) objectives coincide.

2b. Where a learner's intentions and externally imposed objectives are unrelated

Meaningful learning will only occur in so far as the learner is pursuing his own intentions in the learning task. Therefore wherever a learner pursues intentions which differ from his own, meaningful learning will not occur.

In pursuing an external objective a learner cannot be autonomous. By definition the learning is not self-initiated. It cannot be evaluated by the learner in the same sense as in meaningful learning because where the intentions themselves are external to the learner, the criteria for fulfilment of intentions are also outside the learner.

The optimal conditions for achieving external objectives are reduced by the extent to which those objectives differ from the learner's intentions. As the learner pursues external objectives the qualities of personal involvement, interest, commitment and increased likelihood of behavioural and attitudinal change will be absent. This circumstance might be exemplified by the individual who attends a poetry evening class to learn more about the works of Dylan Thomas. On the evenings when they discuss Wordsworth, such a learner will probably co-operate and participate, but that participation will be in pursuit of externally imposed objectives. The learning occurring on the Dylan Thomas evenings would be characterised by meaningful learning; on the Wordsworth evenings the qualities of meaningful learning would be absent.

2c. Where a learner's intentions and externally imposed objectives conflict

The notion of conflict suggests that the pursuit of the externally imposed objectives actually hinders the learner in achieving his own intentions. Meaningful learning will not of course occur under such conditions. In fact, if meaningful learning is associated with positive affect, then the pursuit of conflicting objectives will lead to negative affect. The learner will associate the task with frustration as his own perceived needs are neglected in favour of objectives which are of no perceived intrinsic value to him. For example, a student may feel that the nature of course assessment (externally imposed objectives) demands the retention of so many facts that he is unable to pursue his intrinsic interest in the subject by reading much more widely about it. In such circumstances the pursuit of the externally imposed objective - fact retention - is preventing the learner from pursuing his own objective - wider reading.

**An exploration of the relationship between the multi-dimensional model and the procedural steps**

The multi-dimensional model (see figure 7.2, p202) has been introduced and developed in an attempt to account for, and contribute to, an understanding of the nature of the procedural steps (see figure 6.1, p197) emerging from the data. The model described 'meaningful' learning whilst the procedure is concerned with 'effective' learning. The relationship between the two concepts will be explored by examining how the multi-dimensional model accounts for steps 2 and 3 of the procedure where the link is most illuminating.

*Step 2: The learner assesses task demands*

Analysis of the empirical data suggests that in order to learn effectively learners must, when assessing task demands, take into account not only the nature of the task, but also their own intentions in undertaking that task. The multi-dimensional model assumes that the task demand of meaningful learning is to appreciate the meaning of the task. However, in addition, it demonstrates that meaning is not located within a learning task, but arises out of the interaction between a learner and that task (p207). It therefore follows that meaningful learning depends on the learner pursuing his own intentions in undertaking a learning task. Such learning is effective because it is only by pursuing his own intentions that the learning can become meaningful to a learner; meaning itself arises out of such interaction.

*Step 3: The learner selects appropriate conceptions*

In outlining the procedural steps it has been suggested that learners select the appropriate conceptions to operationalise from the range or 'toolkit' to which they have access. A number of potential inhibitors to this process have been identified: a limited range of conceptions, limited awareness of the learning process itself, and an external locus of control regarding learning.

According to the multi-dimensional model, meaningful learning is achieved through learner autonomy when a learner is pursuing his own intentions. Whilst learning, his activities are self-directed and self-evaluated. The potential inhibitors to this process include those listed above derived from the analysis of the empirical data.

It can be seen that, although using different terminology, the analysis of the data ('effective learning') and the theoretical consideration of the multi-dimensional model ('meaningful learning') are both pointing to a form of learning characterised by learner autonomy. This is by no means a new concept but has been explored and developed by many (Rogers, 1969; Spencer, 1980; Claxton, 1984). The multi-dimensional model contributes to

an understanding of the crucial role of autonomy in effective meaningful learning. It is not simply that autonomous learners are better motivated than others. The model implies that *meaning is created* as the learner interacts with a learning task in a manner appropriate to the pursuit of his own learning intentions. In other words, meaningful learning will occur as the learner interacts with the learning task in a manner appropriate to the pursuit of his own learning intentions. In addition, such learning should be effective in the sense that it will help to fulfil the learner's intentions.

## CHAPTER 9

### APPLYING THE MULTI-DIMENSIONAL MODEL:

#### STUDY 2

This model of meaningful learning has been developed through a process of empirical observation followed by theoretical discussion. The model gives rise to certain expectations about the relationship between the sorts of intentions which a learner is pursuing, and the qualities of the learning which takes place. At present these descriptions of meaningful learning are theoretically derived. However, if the model is appropriate for describing the learning of technicians on open learning courses, then it should be possible to find examples of the qualities of meaningful learning among the experiences of this population of learners.

Rather than return to the data of the original study in order to seek such evidence of the appropriateness of the model, new data has been used to broaden the 'grounding' of the theory (Glaser and Strauss, 1967). A further interview study of Open Tech technician learners was conducted as part of the Open Tech support project funded by the Manpower Services Commission (see chapter 1). The nature of this study is briefly described below.

### Design of the Open Tech study

This study again took the form of a series of focused interviews modelled on the approach of the British Telecom study already reported. Twenty-one learners were interviewed about their experiences of open learning. The subjects were drawn in roughly equal numbers from the population of technicians studying on three different Open Tech courses concerning: Lift technology; Agricultural mechanics; and Refrigeration and air conditioning engineering. All students enrolled on these courses were male, therefore all subjects were male. All subjects were currently employed at technician level in a job related to their respective course.

A complete copy of the interview schedule appears in appendix 12. The concern of the interviews was to explore from the learner's perspective, each individual's experience of studying the open learning course. The interview design focused on a segment of the learning materials which the learner had studied most recently as part of his normal studying. The emphasis of the discussion included learners' reasons for studying, their approaches to studying (and the conceptions and rationale underlying these approaches), and their experiences of the learning content.

All interviews were tape-recorded and transcribed verbatim. These transcripts provide a pool of data in which learners recount their experiences of open learning. Their accounts are particularly concerned with their intentions in learning and the meanings which they attribute to their own behaviour and experiences. They therefore should provide an appropriate source of illustration of the characteristics of meaningful learning - if indeed such learning does occur in practice.

## **Manifestations of the characteristics of meaningful learning in learners' accounts of their learning experiences**

The characteristics of meaningful learning identified in the previous chapter fall into two groups. The first group of qualities in some sense define autonomous learning: learning which is self-initiated, self-directed, and self-evaluated. The second group outlines further characteristics which various theorists have associated with autonomous learning: high interest, increased effort, affective involvement (in particular, positive affect), and changes in knowledge, skill, attitudes and even personality of the learner.

The data will be used to illustrate the various ways in which these qualities emerge in learners' accounts of their learning experiences.

### **Characteristics of autonomy**

It is anticipated that these qualities will be particularly difficult to identify as the experience of the first study suggests that they do not represent dimensions which learners themselves would normally use to describe their own learning.

#### *1. Self-initiated learning*

If self-initiation is measured in terms of learners' reasons for undertaking the course of study, then differences can be identified quite easily. For example, in the case of Howard, it was the firm that he worked for who first initiated the idea of studying:

"I think it was the firm who got us in touch with it. They said it would be a good idea to know more about our job, to learn what's the different parts about this job."

(p1)

This contrasts with Steve who was pursuing the Agricultural mechanics course.

"... our company's pretty good. It probably would have paid for the course if I'd asked them, because they're very educational-minded and it would be good publicity for them... But I decided to do it off my own bat and I'm not reliant on anybody else."

(p43)

Steve not only initiated his own studying but values his independence so highly that he is prepared to pay the course fees himself (about £60) rather than ask the company to sponsor him.

However, the multi-dimensional model is concerned with the way learners actually tackle their study tasks. Meaningful learning occurs when a learner pursues his own learning intentions in the way he interacts with a learning task. Such learning will be self-initiated, but is much more difficult to identify. Steve, quoted above, makes it clear that he is aware of a difference in his own learning between that which is and is not self-initiated. He contrasts this course with his experiences of learning at school.

"... that's the thing about when you're studying for yourself is that you're doing it because you want to do it. You're not doing it because someone's forcing you to do it."

(p12/13)

One way that this self-initiation is apparent in the way Steve tackles a learning package is that his goals in studying are not limited to those set out by the designers of the materials. For example,

"So really, another thing about this is this particular course is training me to get back to studying again."

(p40)

At another point Steve criticises the requirements of the course because they are not in line with his own intentions of learning how to perform better at work.



"...(it's) just as important to know where to find the answer. It's something the examination has never actually taken into account, is your knowledge of how to find the answers to the questions you're asked. It's always, sort of, 'Yes you've got it right', or, 'No you haven't.'"  
(p40)

Where learning is not self-initiated there should be no evidence of independent goals or values. This is exemplified by the way that the following learners responded to the question, 'What were you aiming to achieve in tackling the learning package?':

"I'm aiming to complete it, to have a go at it."  
(Howard, p8)

"Well I suppose really... I'm trying to..., trying to... finish the homework really."  
(Eddie, p9)

In both cases the learners' goals are limited to the requirements of the course.

In a similar way, when learning is self-initiated, the sort of activities engaged in should not be limited to those dictated by the syllabus. For example Vince reports that he always tries to find a short cut in the methods for working out equations presented in the materials (p32). He does not use these short cuts in the examinations because he knows that he will then lose a lot of marks if he makes a small computational error. This activity is self-initiated, partly for the sake of enjoyment, and partly because such short cuts might be useful in his work. Another example is Vic who reads extra textbooks not required by the course.

"I've got two or three other text books that I find very useful. I mean they're not recommended reading for the course or anything, but they're books that I've acquired over the years that I've put into this game. And, you know, I've found them very useful and sort of... it helps sometimes to have an explanation by another person."

(p14/15)

## *2. Self-directed learning*

Self-direction in learning implies that the learner is exercising choice, choosing to focus his attention on one aspect of the course rather than another. Therefore in trying to identify examples of this characteristic of meaningful learning it is appropriate to look for evidence of learners' selecting relevant content.

Vince distinguishes between parts of the course which he perceives to be either relevant or necessary and those which are not, on a number of occasions. For example,

"At the beginning it was a bit... Well, I found it boring at the beginning because they were talking about things that were... Okay, you have to start with basics, but they were saying, 'This is a lift shaft, this is a lift door.' All right, you're on the course, theoretically you should know that."

(p5)

"The 'Health and Safety' side I don't really think should... have come into the course at all, because if you are taking that course and you're a lift engineer, you will have been given the 'Health and Safety' side of it prior to that."

(p9)

Sometimes, of course, a learner may incorrectly conclude that an aspect of the syllabus is irrelevant to his learning needs;

"... we never think of food preservation as to be anything to do with refrigeration and air conditioning I suppose."

(Eddie, p9)

It is easier to identify positive examples of self-directed learning than to demonstrate conclusively that learning is not self-directed. A lack of self-direction is simply characterised by taking the syllabus for granted. Perhaps it could be argued that Howard's learning is not self-

directed where he indicates that it has been left to the tutor to recognise where some parts of the course are irrelevant.

"See, what he's (tutor) doing now..., what he's just been on about is he's going to change it now to go in to more of the refrigeration side... Stop and miss a few out... because some of it is just irrelevant to what we're doing here."

(p4)

### *3. Self-evaluated learning*

It has been argued that a learner can only exercise true self-evaluation if he is pursuing his own learning goals. It is only then that the learner can know, as Rogers puts it "... whether it is meeting his need, whether it illuminates the dark areas which he is experiencing" (1969, p5). If the learner is pursuing externally imposed learning goals then he can only evaluate his learning in terms of external criteria.

In this study learners were asked how they decided that they had finished working on any individual learning package and were ready to go on to the next. Sometimes it was evident that learners were using external criteria to make this decision:

"When I've turned the last page of that particular learning package, or I've read the last leaf in the CRB (Course reference book), you know."

(Richard, p19)

"I thought I'd got them (self-assessment questions) right."

(Howard, p16)

Other learners gave the impression that they were using internal criteria. For example Vic remarked,

"... you just feel, or you know in your own mind whether you understood it or not, don't you?"

(p31)

Vic is clearly using affective indicators to make his decision. However as he continues his explanation, he also appeals to external criteria.

"I mean, yes if I've understood it, then I'll go on to have a look at the essay question and what it's all about. So then I've looked at that and I've thought, 'Well, I couldn't sit down and do what's expected of me there.' So obviously I don't understand it and I've got to go back through it and do a lot more reading through it again."

(p31)

Possibly Vic is describing using internal criteria at first, but then having to appeal to external criteria derived from his extrinsic goal of performing well on the course.

Another example is Brian. All Brian's reasons for studying the course were linked to learning needs that he was experiencing. When asked how he decided that he was ready to move on to the next learning package, he responded:

*Lnr.:* "... just when I feel happy in myself that err... that err I've... That's a good question really. Just when I feel at peace with myself and I feel that I've... got as much out of that as what I'm going to get out of it."

*Int.:* "What sort of things are indicators that you have got as much out of it as you're going to get out of it?"

*Lnr.:* "Well, when I understand it... When I was to go through these fact sheets and actually know that I could sort of figure in my mind what the chap who wrote this was talking about."

(p19)

Like Vic, Brian's initial explanation appeals to affective criteria. His hesitation suggests that he has not reflected on this issue before. When he tries to analyse the mechanism of his decision, the account is reminiscent of a deep-level processing approach. He suggests that he is trying to understand the author's message. According to the multi-

dimensional model, this will only represent meaningful learning if pursuing the author's message is appropriate to Brian's own learning intentions. In fact Brian's aim is to learn how to maintain and mend the machinery on his farm and the aim of the course is to teach students how to maintain and mend farm machinery, therefore Brian's approach should enable him to learn meaningfully.

It appears that true self-evaluation of learning is difficult to identify. By its very nature it appears to be affective rather than cognitive, thus inherently difficult to verbalise.

#### **Other qualities associated with meaningful learning**

##### *4. High interest*

The dimension of interest level is quite popularly used by learners to distinguish between different learning situations. High interest is associated with other qualities of meaningful learning, and low interest with their opposites as illustrated by the following extracts:

###### *Effort -*

"If you're interested in something then I say give it 110%... If I need it, then it's just enough to get by."

(Vince, p27)

###### *Acquisition of knowledge -*

"You've gotta be interested in it... and I've found meself, if there's been something I'm not particularly bothered with, then that's not sunk in. Whereas something that I'm, you know, (interested in)... that sticks."

(Richard, p26)

###### *Effort -*

"... if you find it interesting, you want to work on it don't you? If you don't find it interesting, you just think, 'Oh, what's this then?'"

(Howard, p15)

*Effort -*

"I mean, you only sort of tend to bother about things you're interested in don't you?"

(Brian, p10)

Learners used this distinction spontaneously and clearly found it easy to verbalise. This suggests that the concept of variable interest levels is meaningful to these learners, yet it does not demonstrate that high interest coincides with the pursuit of personal learning intentions. However the following, more complete, comment suggests that relevance to felt learning needs can serve to overcome an initial lack of interest.

"I've always shied away from anything electrical... I mean, if anybody ever started talking about wiring diagrams and this sort of thing, I just didn't register. But then I've never really been bothered before. I mean, you only sort of tend to bother about things you're interested in don't you? But I mean, because all this is sort of part of the course, and because this is exactly the type of thing that I now... I've got to know something about, if not everything, I've got to do it. It's there and it's got to be done."

(Brian, p10)

It is apparent that interest can also occur in aspects of the learning materials which are irrelevant to felt learning needs. For example Richard explains (p19) that he will only answer the self-assessment questions which involve some calculations. When asked why he thinks that it is worth doing those questions in favour of others, he responds,

"I don't see I... I don't sort of think of it in terms of worthwhile. It's err... I enjoy doing them."

(p19)

Bugelski offers an explanation of how such interest and enjoyment might come to be associated with a topic (1970). He suggests that good teachers are able to conduct a lesson in such a way that the learner finds learning the subject affectively rewarding. As a result the learner

associates good feelings with that subject and is happy to pursue it in other contexts.

These examples highlight the fact that it is not sufficient purely to recognise that a learner has intrinsic reasons for learning in order to establish that that individual will learn meaningfully. More significant is the question of whether or not the learner is finding the learning experience affectively rewarding. Learning which is *fulfilling* felt needs will be rewarding, whether those needs stem from a pre-established goal, or they have arisen during the course of the learning event. Therefore it is important that a learner is actually pursuing his own needs in the way that he studies the learning materials. This account is compatible with the explanation implied in the 'procedural steps' (figure 6.1, page 196), which requires that every step must be successfully negotiated in order to learn effectively.

##### 5. Effort

As with levels of interest, learners naturally compare different learning experiences in terms of the amount of effort they are prepared to invest in them. Some learners were observed to explain the discrepancies by appealing to level of interest whilst others appealed to relevance to learning needs. Eddie, for example, put a lot of effort into the maths because he enjoys calculations.

"They sent us some (extra practice questions) through after to do on us own... and I found them, you know, right interesting. They were all right yeah. I enjoyed doing them."

(p6)

This contrasts with his normal approach to studying:

Int.: "What would you do if you felt that you didn't really understand it?"

Lnr.: "Well, I've thought about that actually. I keep thinking, sort of, 'Do you really understand

it?' What I... I'd go back to it. I ain't really gone back to any though up to now..."  
(p11)

Although Eddie intends to go back over the earlier material, he has not actually done so, even though it is clear that he realises that his understanding of it is fairly poor.

Vic explains his effort in terms of relevance to his goals which are to gain the qualification associated with the course.

"... although perhaps there's been a section on 'Enthalpy', it's something that I haven't felt is important to me at the time - to understand about it - to understand it at all. But knowing it's part of my course, I've got to understand it."

(p11)

#### *6. Affective involvement*

The multi-dimensional model suggests that if learners pursue their own learning intentions in interacting with a learning task then their affective involvement should be relatively high. In particular such meaningful learning should be associated with positive affect.

Steve was quoted earlier as making a distinction between self-initiated learning (the open learning course), and learning imposed upon him (learning at school). He associates school learning with boredom (ie. negative affect), whereas he reports of the open learning course,

"I find it interesting. I find it all interesting at the moment - especially if I learn something from it - which is a bit difficult from my position. If I were completely fresh to the subject then everything would be learning."

(p12/13)



This comment is particularly interesting because it also indicates the part which self-evaluation plays in Steve's learning. It is an essentially private process of evaluation for a learner to distinguish between *learning* something new, and simply *studying* something which is already familiar. Another learner, Vic, also commented that he found it boring studying material on topics already familiar to him, and much preferred learning new material.

"For me the first bit has been really boring. That's made it even more of a struggle. It's like going back to basic physics 'O' level which you did nearly 20 years ago... It's the sort of thing you don't remember, you remember the basics, but you can't remember enough say to write an essay about the details and all the rest of it. So you've got to plough through it. And you know, I'm really waiting to get into the next few lessons where you're expanding on things that you're... you know... You're actually working on something, and you're doing something about what you're actually working on."

(p5)

In this example the different types of affect can clearly be associated with different types of intentions which Vic was pursuing. Much of the earlier material was already familiar to Vic, therefore studying it didn't satisfy a felt learning need. His aim in studying was purely to achieve the extrinsic goal of coping with the assessment entailed in the course, namely the essay. Vic implies that he is really looking forward to (ie. associates positive affect with) learning about new things which will be relevant to his work. These are the aspects of his intentions which stem from felt learning needs.

In another example, Howard distinguishes between studying which has bored him and that which he finds interesting. When he was asked what he got out of studying the most recent learning package, the following dialogue ensued:

Lnr.: "I didn't find it interesting. It just bored me. I just didn't have the patience to do it. I've got better things to do than do maths - work them out. Other sections is interesting, like

them what we've done, but when you get on to start doing that, I just can't do it."

Int.: "Which sort of sections were interesting then? The earlier ones?"

Lnr.: "Yes"

Int.: "And what were they about that they were interesting?"

Lnr.: "Well, some of it were things that we needed to know. So you found it interesting then, because you think, 'Well, you're going to get a lot out of this'. So you learnt it and you enjoyed it because you were doing it every day."

Int.: "I see, and how did those things help you actually on the job?"

Lnr.: "Well, when you got on a job and a thing would come up and you'd think, 'Oh, we've learnt about this, this is what we've been doing.' So it were coming in quite handy. You could tell somebody what you'd done."

(p7)

In this extract a number of characteristics of meaningful learning were associated with the material perceived as relevant. The relevant material was experienced as 'interesting'. For example, Howard associated positive affect (namely 'enjoyment') with studying it the materials. He felt that he had successfully 'learnt it', and reported that he relates it to his work and talks about it to others. In contrast, studying the irrelevant material lead to the negative feelings of boredom and impatience. Howard resented the amount of time he had to spend on it, and in addition, was left with the perception that he was not very successful in learning it.

### *7. Learning outcome*

The last example quoted illustrated how meaningful learning lead to the effective recall and relating of the content of the learning material. This contrasted with the studying of mathematics, the main outcome of which was for Howard to conclude that he could not do mathematics.

Eddie's experiences of the same course were very different. His enjoyment of the calculations, reported earlier, was reflected in his recollections of the most recent learning package studied.

Int.: "What was the last package, lesson four, what was that about?"

Lnr.: "It were... it were... it had a lot of sums in it. I know that err... I dunno, can't remember."  
(p3)

This illustration supports the contention that the qualities of meaningful learning will be associated with those aspects of the learning task which are of intrinsic interest to the learner. In this case Eddie was purely enjoying the calculations for their own sake, as a result he has no recollections of the topic to which they related. This example could also illustrate a surface approach to learning. Eddie has focused his attention on the superficial aspects of the learning task and missed the author's message altogether. This analysis would be accurate but not particularly illuminative in trying to understand the mechanisms underlying Eddie's learning behaviour.

Another example of meaningful learning outcome is provided by Vince who was enrolled on the lift engineering course. During the interview he was asked to explain the main environmental effects of lifts, since this was the topic of the last learning package which he had studied. The learning package discussed such things as the location of lifts in a building; lift capacity; heating and ventilation. Vince's response (p7) was lively and detailed, full of personal embellishments. However, it only covered heating and ventilation, and it became clear that these topics were of particular interest and concern to Vince in his role as shop steward. All the other topics covered by the materials were ignored.

## **An exploration of the conditions under which meaningful learning occurs**

These illustrations demonstrate that the qualities of meaningful learning outlined do indeed characterise the ways in which some of this population of students learn. However they have also served to highlight the fact that it is too simplistic to predict that meaningful learning will always and only occur where a learner has an intrinsic interest in studying a particular course. The more pertinent concern is that the learner is actually pursuing his own intentions (or intrinsic interest) in the way that he interacts with a study task. In order to explore this hypothesis three individual cases will be considered in more depth. All three learners have intrinsic interest in their studying, but not all of them demonstrate meaningful learning.

### **Case Studies: Vince and Richard**

#### **Their intentions**

Most learners have a range of reasons for undertaking a course of study. However, often there appear to be only one or two dominant themes underlying the variety. For Vince, a particular concern seems to be his status in the eyes of others. This is manifested in a number of ways.

Vince is concerned to prove to others at work that he is professionally competent. He sees acquiring qualifications as a means to this:

"... the more exams you've got that you can show up and say, 'I've got this exam and this exam, and I've passed these...' It proves to them that theoretically... you can do it. And when you're an area engineer all you need is the theoretical side of it."

(p6)

Also, in more immediate terms, he feels the need to prove his knowledge in conversation with colleagues:

"You see, this is my goal: it's to be able to stand up in this branch and say, 'I'm not bothered about what you and you say because I know you're wrong and I'm right.'... and to make sure you are right!"

(p28)

These two reasons, although both concerned with status, have different implications for meaningful learning. The first is an extrinsic learning goal. In this case Vince's interest is in the qualification itself and the message which that will communicate to others. The desire for such a qualification *leads to* the recognition of a learning need, ie. to study the syllabus sufficiently to pass the exam and acquire the qualification. However, it does not *derive from* a learning need experienced by Vince. On the other hand the second example does imply that Vince is prompted by directly experiencing a learning need. He wants to be able to be confident enough in his own knowledge and understanding of the job to disagree with the opinions of the more experienced fitters in his branch.

In a parallel situation Vince explains:

"I'm going out to beat my two older brothers really."

(p26)

It emerged that both his brothers were electricians and they talk about their work at home. Once again Vince is anxious not to be shown up in conversation; he is responding to a felt learning need.

In addition Vince is concerned about his actual ability to do the job:

"... I don't feel confident in myself that I could do the tasks that are asked of you as an advanced fitter, physically do it, you know."

(p3)

Overall it can be seen that Vince's intentions in studying predominantly concern learning needs which he experiences or recognises in particular

situations. He feels that he would cope better in these situations if his knowledge and understanding were better. This means that his learning has a very personal significance, and he is more concerned with its personal value -

"If you've got the theory behind you, it boosts your ego."

(p4)

- than with academic excellence -

"The actual percentage, I'm not bothered about. As long as I know I've passed it I'm okay. So what if I'm only 4% over a pass mark, but what do you want? You get you 80%, all well and good for you. At the end of the day you've only got a piece of paper either way."

(p33)

The multi-dimensional model would suggest that if Vince were to pursue such learning intentions in studying, his learning would be characterised by the qualities of meaningful learning.

In many ways Richard is in a similar situation to Vince. He is following the same course as Vince and holds an equivalent position at work. His reasons for undertaking the open learning course also represent a mixture of felt learning needs and extrinsic goals.

Richard was a fully qualified electrician working on the railways before he decided to become a lift technician. About the course, he says:

"As I say, I started off as an electrician. So like the mechanical side of this were unknown to me... I thought, well, that's the side I want to know a little bit about."

(p2)

This comment suggests that he feels the need to learn more about the mechanics of lift technology, but probably not on the electrical side. This difference in concern is later confirmed:

"I didn't foresee any problems with the course, I've already got *City and Guilds*, so..."

electrically I didn't foresee any problems anyway. From the mechanical aspect... as I say, that's why I was interested so..."

(p3)

Richard is generally confident about his ability to cope with the course, and, like Vince, appears to be concerned only with passing rather than achieving high grades.

"I know I can pass. I mean, you know, even if I only pass by one mark, I still know I can pass. I'll do enough to pass."

(p22)

Richard also mentions that he feels that if he *did not* enrol for the course...

"... there's that many on the course that err... suppose you go in for a pay rise, they could easily hold it against you."

(p3)

Thus Richard's intentions are quite mixed. He does feel that he needs to learn more about the mechanics of lifts, whilst he is quite confident about the electrics of lifts. In fact overall he gives the impression of being fairly confident about coping with the course without too much trouble. Much of the course concerns electricity and he knows all about that already. His further reason for studying, that his bosses would disapprove if he were not enrolled for the course, is clearly an extrinsic interest rather than a response to a perceived learning need.

Their quality of learning

The multi-dimensional model of learning would suggest that when Richard was studying the mechanical aspects of lift technology, his learning would be characterised by the qualities of meaningful learning, but otherwise, it would not be. In fact there is very little evidence of any of the qualities of meaningful learning in Richard's account of his experiences of the open learning course. Beyond the initial discussion

about his reasons for studying, mechanics are not mentioned again. His commitment to the course appears to be fairly low, and he gives it low priority amongst the other facets of his life.

"If I have time after me tea one night, and there's nothing on the box, you know. Then I'd have a look (at the learning materials), but..."

(p5)

"Normally I pick a night where... say I can't do much to the house, or it's raining or something... I seem to be in the frame of mind for it then because - I can't explain it to you - but I couldn't sit down and do those (learning packages) when I could be doing a job in the house."

(p14)

It is not that Richard is a lazy person, but simply that he feels the need to work on his house more urgently than the need to learn. His learning does not appear to be characterised by a strong drive from within. Possibly linked to this is a lack of direction. He is not responding to a felt learning need and as a result his effort seems to be geared simply to what captures his attention.

"You see, I start reading... and if the spirit moves me, type of thing, then I'll finish the chapter. Then I'll just continue reading it depending on how I feel. Generally, if I'm not interested, I'll just pack the whole thing away."

(p14)

One of the aspects the course which does capture Richard's attention is the calculations:

Int.: "What would prompt you to do a certain question (self- assessment question) then... why would you bother?"

Lnr.: "If it was something you had to calculate..."

Int.: "Why do you feel it's worthwhile doing those ones?"



Lnr.: "I don't think of it in terms of 'worthwhile'.  
It's err... I enjoy doing them."

(p19)

In this case the motivation for applying effort does not appear to be derived from Richard's original intentions for studying but rather the enjoyment of engaging in the activity. As discussed earlier such interest also appears to coincide with meaningful learning.

Returning to Vince, he is also concerned with fitting the activity of learning amongst his different priorities in life. However, he gives it a higher priority than does Richard:

"I'd rather stop at home on a Saturday night and read something electrically than go out to the pub for a drink. I mean... I *love* going out for a drink, I go out most nights. But then if there's something I've got to do electrically or mathematically, then I don't mind."

(p29)

Vince is willing to forego other enjoyable activities, and apply effort to studying electrical or mathematical subjects. Here he is displaying two of the qualities of meaningful learning already identified. He immediately goes on to distinguish between those topics to which he is prepared to apply effort and those which will only receive minimum attention.

"... If it's reading through stuff like 'Health and Safety'... okay, I do it. But it's something that I think, 'okay, I've got to do it, let's get that out of the way then I can get back to... "

(p29)

He has already explained why he feels that for example, 'Health and Safety' should receive less attention,

"... really, I think that the 'Environmental' and the 'Health and Safety' part was irrelevant to me, I didn't really take much notice of that, although I read it."

(p10)

Thus these topics are rejected because they are not relevant to his perceived learning needs. In making these judgements Vince is exercising autonomy and directing his own learning. He is not simply accepting the syllabus as it stands, but selecting from it according to his own criteria of relevance. Once the selection has been made it has an important influence on his approach:

"... if you're interested in something then I say, give it 110%. If you need it, then I give - I don't know, maybe I'm wrong - maybe 60%. If I'm interested in it then it's 110%. If I need it then it's just enough to get by."  
(p27)

It is clear here that Vince recognises that when he is pursuing his own learning intentions, he is prepared to put in a lot of effort. On the other hand, where he is pursuing external goals (according to Vince's terminology 'needing it' means that the topic is part of the syllabus and so must be studied for the sake of the course), he will put in minimal effort. This is a distinction predicted by the multi-dimensional model. Richard seems to be applying just enough effort to get by: "I'll do enough to pass." (p22), throughout the course, suggesting that none of the learning is meaningful for him.

Another quality of meaningful learning suggested by the model is a high degree of affective involvement. It has already been observed that Vince's reasons for studying are very personal - his self esteem is closely tied to his knowledge about electrics. For him, the primary rewards of learning are affective.

"It's a great feeling to be able to turn around and say, 'Well, this is why, and I know I'm right.'"  
(p27)

"If you've got the theory behind you it boosts your ego."  
(p4)

For Vince both the process of learning and its outcomes demonstrate the characteristics of meaningful learning when he is pursuing learning

relevant to his felt learning needs. He describes his feelings when he first tackled a learning package concerning some electrical aspect of lift technology, and contrasts this with mechanics topics:

"This sounds interesting. It sounds better than, 'a piece of metal having a tolerance and a stretch factor.' I like this. And you go home and you talk about things like... well, I don't know, you talk about doing something in the house."

(p27)

It is interesting to note that Bugelski (1970) specifically mentions that where learners associate positive affect with a learning experience they are more likely to talk about it at other times. This can be contrasted with the negative affect which Vince associates with topics that he is pursuing for external reasons:

"Like at the beginning of the learning package I found it boring. But I trudged on because I know I needed it for what I wanted in the end... the bit of paper at the end."

(p25)

Richard and Vince demonstrate different conceptions of learning which seem to reflect the different natures of their intentions. Wherever a conception of learning is apparent in Richard's account of his experiences of learning it implies a passive view of learning. For example when asked to explain why some people are better learners than others he responds:

"Well, the only thing I can say on that is if you got a memory, you know, you're two parts there."

(p26)

This suggests an external locus of control, where success in learning is attributed to factors beyond the learner's control. Richard continues in the same vein:

"You've gotta be interested in it... and I've found meself, if there's been something I'm not particularly bothered with, then that's not

sunk in. Whereas something that I'm, you know  
(interested in)... that sticks."

(p26)

This contrasts with Vince's distinction between topics that he is and is not interested in which has already been quoted. His distinction concerns the amount of effort he is prepared to put in (p27), rather than the passive notion of learning either 'sticking' or 'sinking in'.

Vince appears to be much more aware than Richard of different types of learning appropriate to different contexts. He demonstrates the use of the distinction between 'learning-for-life' and 'learning-in-school' (or in this case 'learning-for-the-training-course') first identified by Saljo (1979). This is particularly clear in an extract from a discussion about his approach to studying the learning package on which the interview was focused. Vince mentioned that he paid particular attention to a paragraph on the dimensional tolerances of the location of lift machinery...

Int.: "Why that particular bit?"

Lnr.: "Not for the learning package. It's once again  
something I would be able to use in my job."  
(p18)

After discussing the relevance of this topic to his work as a shop steward, Vince then continued his account of his approach to study:

"Then it would be, like back to the learning  
package to make sure in case they ask me any  
questions about it."

(p19)

It is apparent that Vince applied a personal conception of learning to his studying of the dimensional tolerances, and a ritualised conception to the rest of the materials.

Therefore, although both Richard and Vince have at least some intrinsic interest in studying the Lift technology course, it appears that only Vince is experiencing meaningful learning. The relative absence of qualities of meaningful learning in Richard's descriptions of his learning

experiences could be accounted for in a number of ways. One explanation just outlined is that Richard's conception of learning creates a barrier to meaningful learning. He differs from Vince in that he appears to conceptualise learning purely in terms of memorising information, whereas Vince operates a more personal conception of learning. However, it could simply be that the course is not meeting Richard's learning needs with regard to the mechanics of lift engineering and therefore he has become demotivated and lost interest. This is possible, but unlikely as the course was designed to meet the needs of learners such as Richard who are practising lift technicians yet recognise that they have a gap in their theoretical knowledge.

#### **Case Study: Brian**

The third case study, Brian, tends to confirm that the operationalising of conceptions of learning can form a barrier to meaningful learning for some learners. Brian was studying a different course, the Agricultural mechanics course, but his intentions were akin to those of Vince. Brian ran his own farm in partnership with his brother, the two of them having taken it over from their father only in recent years. No one else suggested that Brian undertake the open learning course, let alone put pressure on him to do it. In that sense Brian's learning was self-initiated. His main reason for studying was that he wanted to be able to mend the farm machinery.

"... it's really purely for knowledge. I'm not really interested in the qualification side of it... It's just purely, you know, for the err... knowing the correct procedure for doing something, instead of getting it to pieces and then thinking... 'how the hell do I get it back together again?'"

(p1)

It can be seen from this extract that Brian's interest in the course was very practical and clearly stemmed from a felt learning need. In fact a

high level of affective involvement is implied here as it is clear that Brian found it very unpleasant when he didn't know how to deal with the machinery for which he was responsible. Later he reveals another reason for strong affective involvement. Brian explained that, at present, the only person on the farm with any mechanical knowledge was an established employee of his father's generation. He continued,

"... if you're driving an implement and you get a problem with it and you've got to go running to him, you know, to fix it, it doesn't do much for your ego."

(p4)

It can be seen that Brian's reasons for studying stem from felt learning needs and lead to an intrinsic interest in the course content. His overall approach shows the qualities of meaningful learning in that there is a high level of affective involvement. However in the detailed discussion of his experiences of studying a section of the learning materials, the qualities of meaningful learning were evidently lacking.

The topic covered by the materials under discussion was, 'alternator voltage regulation', a subject predominantly concerned with electrics. Brian made it clear that he did not enjoy studying this learning package and put it down to the fact that

"I hate electrics. I must admit I'm not very good at them at all..."

(p4/5)

"... electrics to me are a real black art..."

(p10)

It was not that the topic was perceived as irrelevant to his learning needs, but rather that for some reason Brian associated the topic with negative affect.

"When you've been working all day and you're perhaps feeling tired... and then you come to do something that you don't really enjoy doing and that you know you're going to have problems

with... you, sort of... you're not helping yourself to start off with."

(p21)

In studying this part of the materials Brian does not appear to have been self-directing or self-evaluating in his approach. He has relied on the external criteria of self-assessment questions to direct and evaluate his learning:

"... you've got to think back through the err... previous writing... when they ask you a question. You have to actually figure in your mind what err... how does that particular item work...?"

... Well obviously it's one way of taking in what... I mean you can read, and read, and read, but whether you're taking it in and storing it in your memory cells is another matter."

(p14)

When asked to explain about alternator voltage regulation it was clear that Brian had 'taken in' very little of it. His first response was to avoid the question and explain why he could not answer it (p5/6). He then went on to list, in a disjointed fashion, all the topics that he could remember which were included in the learning package (p6). Thus Brian's learning was not characterised by the successful acquisition of knowledge.

The example of Brian demonstrates that a learner might pursue a learning course which is relevant to his own perceived learning needs and yet not learn meaningfully. It has been suggested that it must also be asked, is the learner pursuing his own learning intentions in the way he is tackling the learning task? Brian was himself asked what his immediate aims were in studying the materials, and his initial response was in keeping with his learning intentions;

"I was hoping to achieve a better understanding of the workings than what I had previously reached, which was nothing."

(p9)

He then went on to explain that he did this by reading through the text. When asked what his aims were as he was reading, he responded;

"Well, I'm aiming to remember as much as I can to start off with."

(p10)

It appeared that Brian believed that an understanding would be achieved by repeated reading.

"... what I'm hoping to do is to go over it and if I can remember something different each time, then eventually I shall be able to, sort of, fit it all in."

(p12)

In line with this interpretation Brian gave his definition of learning as follows:

"... I guess it means remembering what you've just read, cause that's what I find difficult."

(p20)

It appears to be Brian's conception of what learning involves, ie. memorising, that is inhibiting him from learning meaningfully. His attempts to memorise are not, as he hopes, leading to an understanding which would meet his learning needs. Brian recognises that he has not been very successful and yet is not able to suggest alternative approaches to learning that might be tried (p22). Linked to this might be the fact that Brian explains his failure in learning to factors outside his control. In particular he uses the example of his brother who is reported to be a much better learner.

"... I think it's fair to say he's got more brains than me any way... It's like my school report said, I just gotta concentrate more. Although as I say, I do concentrate, it just doesn't always register. I don't know why... chromozones or something like that."

(p21)



It was pointed out in the discussion of the data from the earlier study that such an 'external locus of control' is likely to inhibit effective learning because it leads the learner to believe that he can do nothing to improve his learning performance.

### **Developing an appropriate model**

This further empirical grounding shows that the qualities of meaningful learning can be found in accounts of the learning experiences of Open Tech learners. Experience of gathering the interview data revealed that some of the qualities identified are very meaningful to learners themselves. Learners actually choose to describe their own learning experiences in terms of level of interest, effort and enjoyment. However, the more fundamental qualities of autonomy for example, self-initiation, and self-direction and self-evaluation are only implicit in learners' accounts of their learning experiences. Interviews are not the ideal way to explore these.

It does appear that the different characteristics attributed to meaningful learning tend to be found in association. As expected, these qualities are generally associated with intrinsic learning goals. However, it has been suggested that, although intrinsic interest might be a necessary condition, it is not a sufficient condition for meaningful learning. An equally important criterion is whether or not the learner is tackling a particular learning task in a manner appropriate to the fulfilment of his own learning needs. If this is the case, then the learning will be experienced as rewarding and thus associated with positive affect. If not then, as the case studies show, there are a number of ways in which meaningful learning can be inhibited. For example, autonomy can be viewed at different levels. Learning can be self-initiated and self-directed at the level of choosing which course of study to undertake. Yet in actually

studying, a learner might rely on external sources to provide the initiative, to direct and to evaluate the learning. This has been described as adopting an external locus of control in learning. The case studies have also illustrated that a limited range of conceptions of learning may lock the learner in to an inappropriate approach. Furthermore some learners can be held back because learning is not 'thematized' for them. They believe that the nature of learning is self-evident and therefore not an object for reflection. This will form a barrier to meaningful learning because it will prevent the learner from adjusting his definition of task or his approach to his own intentions.

In seeking for an appropriate model of effective learning at technician level in the Open Tech two different formulations have been proposed: the 'Procedural Steps' (outlined in figure 6.1, page 197), and the Multi-dimensional Model (outlined in figure 7.2, page 202). The present discussion enables us to see how these two models fuse together. The multi-dimensional model elucidates the principle underlying the procedure. Meaningful learning will only occur where a learner interprets and pursues the task demands in terms of his own learning intentions (ie. not the educator's intentions or the author's message etc.). This is borne out by the empirical observations of the second study. The procedural steps then elaborate on the process by which meaningful learning is achieved. Once again, the empirical observations are compatible with the model. In order to fulfil his learning intentions the learner must be able to identify particular task demands, select suitable conceptions of learning, and then operationalise these successfully. This study begins to confirm the appropriateness of the model. The question of usefulness must be explored by applying the principles emerging to practical problems of learning in the Open Tech.

## CHAPTER 10

### CONCLUSION

This research was initiated by some very practical concerns about the effectiveness of technician learning in the Open Tech. The project was funded to develop guidelines for design based on a thoroughly researched understanding of technician learning in this context. As the work progressed, this general aim was both refined and extended. The concluding chapter will review the aims as they have emerged, consider the main contributions made by the research, and discuss the ways in which the aims have been achieved.

As the context provided by the Open Tech was analysed, it became apparent that in practice, the emphasis on removing barriers to learning only operated at a very superficial level. Organisational barriers had been identified and attempts were being made to ensure that access to courses would be less restricted and more flexible. However, the promotion of learner autonomy, which lies at the heart of the concept of open learning, was not being seriously addressed. This project therefore set out to identify the deeper, psychological barriers which inhibit effective open learning, and to suggest strategies for removing these. The study took a phenomenological perspective in tackling this task, seeking to understand open learning from the point of view of the technician learner. A review of the literature suggested that the analysis should attempt to provide explanations of the intentions and meanings underlying technicians' accounts of their learning experiences. In particular, the

research should aim to describe the components of learners' approaches to studying and account for the factors which influence their approaches.

### **A new metatheory**

There is relatively little precedent for adopting a phenomenological perspective in learning research. Therefore the basic assumptions underlying this research were explored to make the nature of the inquiry explicit. In the process a metatheory was formulated with clear implications for the pursuit of learning research. In particular it incorporates a view of man as *essentially* a learner. In other words, man is by nature a learner; he does not have to learn how to learn. Instead of asking how they can teach people to learn, educators and trainers should be asking, what inhibits individuals' natural inclination to learn. In parallel to this, the metatheory incorporates a view of man as an actor rather than a reactor. Traditionally, educationalists have sought, in effect, to motivate students to change from a passive, resting state to an active involvement with a learning task. The new metatheory suggests that students will always be active in pursuit of some goal. Therefore the task is not to motivate into action per se, but to steer the activity into fruitful channels. It can be seen that this metatheory represents a major shift in emphasis which has an important bearing on the research in hand. Open learners cannot be seen as malleable clay to be tempted by incentives into engaging in a learning course, which will then, by expert design, mould them into the desired end product. Instead, they must be recognised as individuals with their own purposes, who can choose whether or not they want to address a particular problem, using their own natural learning abilities.

The metatheory also provides guidelines for scientific inquiry, suggesting that scientific inquiry parallels man's concerns as a natural learner. Thus, the scientist's task is to develop understandings of the world which help him to cope with the world. In the case of the study of behaviour, it is not appropriate to assert general laws, but only to

provide explanations of a particular context. Such explanations should be judged on their utility: to what extent do they illuminate and equip for appropriate action?

This exposition of the metatheory led to a reformulation of the scientific aims of the research. In order to be consistent with the underlying assumptions, the research must seek to develop an appropriate and useful model of technician learning in the Open Tech. The model should be appropriate, in that it explains the accounts which learners give of their learning behaviour. It should be useful, in that it helps others to understand the experiences of technician open learners in such a way that they are better equipped to fulfil their roles of designing, tutoring, and assessing open learning courses.

#### **The 'Procedural Steps': An explanation of learners' accounts of their learning experiences**

On the basis of this clarified metatheory, the research set out to look at technicians' experiences of open learning, and attempted to provide an appropriate explanation of them. The outcome was an account of the steps involved in the process of effective learning for these learners (see figure 6.1, page 197).

These procedural steps suggest that learning is initiated when the learner's own intentions prompt him to address a learning task. On engaging in such a task, the learner must identify the task demands before he can undertake that task. Here the procedural steps demonstrate that the nature of task demands is ambiguous. Task demands are not simply defined by what was intended by the designer of the task. They are also influenced by the learner's own intentions in undertaking that task. Therefore, to learn effectively, the learner must be able to recognise the implications of his own intentions, and to incorporate them into his own definition of the task demands.

Once the task demands have been identified, the learner must then tackle the task in an appropriate way by selecting a conception of learning to operationalise. Analysis of the data revealed that many learners had a wide range of conceptions to select from. (In fact, a number of new conceptions emerged which have not been widely discussed in the literature, such as 'learning as mental exercise'.) Some conceptions will be more appropriate to some intentions than others. For example a ritualistic conception (eg. learning is a preparation for assessment) will be appropriate for an extrinsic goal (eg. gaining the qualification). Obviously the wider the pool of conceptions to which a learner has access, the more likely he is to be able to make an appropriate choice and therefore learn effectively (see table 6.8, page 186). In addition, it was recognised that some conceptions are more sophisticated than others and make a greater contribution to effective learning (see table 6.9, page 188). This explanation proposed by the procedural steps combines a developmental and interactionist interpretation. A learner's range of conceptions is a personal attribute which can grow and develop. Yet the particular conception which he applies to a learning task will depend on his perception of the demands of that specific situation.

The learner's choice of conception will introduce particular aims in tackling a learning task. These aims must then be achieved through study activity, which can of course be conducted with varying degrees of skill. The procedural steps again propose that learners have a range of accessible skills which vary from learner to learner in their extent and sophistication. The wider the range and the more sophisticated the accessible study skills, then the better able is the learner to operationalise his conceptions successfully. Therefore he is ultimately more likely to study in a manner appropriate to the task demands, and thus achieve his learning intentions. In chapter 1 it was reported that study skills training seemed to help those who were already fairly successful learners but did not effect the poorer learners. The procedural steps can account for this if it is proposed that the fairly successful learners were already able to assess task demands in the light of their own intentions, and had access to an adequate range of conceptions. Such learners would be able to apply newly learnt study skills very

effectively. On the other hand, learners who were not able to negotiate the earlier steps to effective learning would not benefit from a broadened range of study skills. These learners would show no improvement in their learning.

Finally, the procedural steps abandon the linear pattern and become cyclical since they imply that learning outcome is matched against the learner's intentions. The proposal is that effective learning constitutes a problem recognised, defined, tackled and resolved. Thus the effectiveness of learning should be measured by the extent to which the learning outcome matches the learner's intention, rather than by any external objective criterion. This claim highlights the primacy of the role of learners' intentions in defining the nature of effective learning.

#### **The Multi-dimensional model of effective learning**

Having developed an explanation of learners' accounts of their experiences, the research then sought to uncover the model underlying the procedural steps. The work of Marton and Saljo (1976a) was taken as a starting point because it was conducted from the same phenomenological perspective. Their original model was adapted and extended to account for the current data, and thus the 'multi-dimensional model' was developed (see figure 7.2, page 202). The major contribution of this formulation is a recognition of the importance of precision in identifying the location of meaning in learning. The Marton and Saljo formulation follows conventional models in assuming that a learning task is primed with meaning by either the writer or designer of that task. Thus, meaning is located within the task. The multi-dimensional model asserts that meaning cannot exist independently of a person. A learning task does not have meaning, but only *potential* meaning. Meaning itself arises as the learner interacts with the task in pursuit of his own learning intentions. This subtle shift in the location of meaning from within the task, to interaction between learner and task results in a major shift from a communication model of learning to a problem-solving model. As we have

seen, the account of learning outlined in the procedural steps is essentially of a problem-solving exercise.

The multi-dimensional model gave rise to a definition of meaningful learning: 'that meaningful learning takes place when the learner interacts with the learning task in pursuit of his own learning intentions' (page 206). With such a precise definition of meaningful learning, it was possible to identify some of the qualities which should characterise meaningful learning. As a result it became apparent that meaningful learning can be equated with autonomous learning because it is characterised by the same defining qualities of self-initiation, self-direction and self-evaluation. Drawing on the literature it was further hypothesised that the qualities of high interest, increased effort, cognitive and affective involvement, and changes in the knowledge, skills, attitudes and possibly personality of the learner should all be associated with meaningful learning. These qualities serve to make the learning effective in achieving learner goals, and lead to the conclusion that effective learning requires learner autonomy.

#### **Identifying the psychological barriers to effective technician open learning**

Having reviewed the major landmarks in the progress of the research, the task is now to consider the extent to which the aims of the research have been met. To what extent have the psychological barriers inhibiting effective open learning for technicians been identified, and what strategies can be suggested for removing these?

Using the procedural steps to illuminate, it is observed that anything which prevents a learner from progressing through these steps will inhibit the effectiveness of his learning. The steps will therefore be considered in turn to identify potential barriers.



### *Learners' intentions*

It has been asserted that all learners will have intentions of some sort if they are addressing a learning task. However, it appears that some types of intention are more likely to lead to meaningful learning than others. In particular, the multi-dimensional model implies that interest in the content of the course is a prerequisite for meaningful learning. These assertions are supported by another study of technician open learners (Sagar & Strang, 1985) where a link was demonstrated between performance on course assessments and the dominance of vocational intrinsic goals over vocational extrinsic goals. It was also observed in this study that learners who were able to enumerate a greater variety of goals performed better on course assessments than those with a more limited range.

The implication is that in order to learn effectively, learners must be allowed to pursue their own intrinsic interests. However, such a demand is contentious in a training context. Training has a much narrower definition than for example education. Training must normally lead to a specific competence which is recognised and valued by the providers of that training. Employers are generally obliged to justify any expenditure on training in terms of improved output. There is, therefore, very little scope for providing learning opportunities to be used by learners for their own particular ends - employers' goals cannot be denied. Naturally trainers are not very receptive to the idea that they must allow learners to pursue their own intentions. However the model demonstrates that it is also a mistake to think that learners' goals can be denied. If learners cannot pursue their own learning goals then they will not learn effectively, no matter how relevant the learning task may be to the employer's goals. Effective learning is therefore maximised where learners' and course goals match. The message for providers of Open Tech courses is that they must attempt to match learners' goals and course goals.

In order to match learner goals and course goals, employers would be advised not only to acknowledge that learners have their own goals, but

also to find out what those goals are, and where the discrepancies lie. In talking to employers during the course of this research it was apparent that they generally attributed a very narrow range of goals to learners, comprising predominantly vocational-intrinsic goals. Yet the evidence is that learners have a wide range of intentions in studying. Many of their aims are compatible with the employers' training concerns and could be accommodated in the design of a course.

Furthermore there seems to be a need to educate employers or other providers of open learning for technician training, about the qualitative as well as quantitative variations in learner motivation. Many learners reported that employers suggested that they should undertake the Open Tech course because they would need the qualifications for promotion. This encourages extrinsic motivation. Instead, with careful design, intrinsic motivation could be encouraged by reference to learners' own goals throughout a course, from the publicity materials to the assessments.

It must also be acknowledged that learners themselves are not necessarily aware of all the potential intrinsic interest held for them within a course. In an attempt to influence learners directly, a leaflet has been designed which is intended for use as a counselling tool with technician open learners (*Secrets of Success*, Strang & Sagar, 1986; see appendix 13). This leaflet encourages learners to reflect on their reasons for studying to help them to decide whether to undertake a particular course and to be sure that it is the right course for their own goals. It also introduces the difference between intrinsic and extrinsic reasons and encourages learners to identify all the intrinsic interest which a course might hold for them. The more that a learner is aware of his intentions in tackling a learning task, the more likely he is to be able to interpret the task demands in terms of those intentions. In this way his learning will be self-directed, and can be self-evaluated. In other words, his learning will be characterised by the qualities of meaningful (and autonomous) learning.

### *The interpretation of task demands*

The next stage of the procedural steps involves the learner in assessing the nature of task demands. It can be deduced that, for an *assessment* to take place, a learner must realise that learning task demands can vary. Only when a learner recognises that learning tasks can make different demands (where learning is 'thematised', Saljo, 1979a), is he in a position to assess the demands of a particular task.

The procedural steps refine the process further and propose that in order to learn effectively learners must take into account *both* their own intentions and the nature of the task. This builds on the work of Miller and Parlett (1974) who recognised that some learners are more alert than others to the cues available from which to gauge the assessment demands of a course. The model proposed in this thesis implies that the demands of a task do not depend solely on the criteria established by the providers of that task, but also to the learner's own purposes in undertaking that task. If a learner is to be effective he must pursue his intrinsic interest and so be able to recognise how to use a learning task in order to fulfil his own intentions. In fact it appeared from the data that this population of learners is very concerned about course assessment criteria. This does not seem appropriate for technicians whose intention is generally to apply their learning in practice. Technicians may need help in learning how to translate their intentions into task demands. For some, this will also involve alerting them to the variable nature of learning tasks. Learning tasks themselves should be designed with an awareness of the types of approaches which they will encourage. For example, the data suggested that self-assessment questions provide a powerful tool for influencing learners' interpretation of task demands. (This also applies to course assessment which will be discussed later.)

### *The selection of appropriate conceptions of learning*

One of the aims emerging as the research progressed was to ascertain whether learners' approaches were personal or situational. As has been

pointed out, the explanation provided by the procedural steps implies a mixture of personal and situational influences on learners' selection of conceptions of learning. The most effective learner has access to both a varied and sophisticated range of conceptions, and is skilled in selecting the conceptions appropriate to a particular situation. It follows that those concerned with helping learners to learn more effectively should help them to develop their range of conceptions, and to recognise which conceptions are appropriate in which learning situations. A number of approaches to direct intervention with students incorporate these aims (Gibbs, 1981; Thomas & Harri-Augstein, 1985; Brew, 1981).

It is also important for designers and providers of courses to recognise the myriad of subtle messages conveyed about their underlying conceptions of learning through the design, presentation and context in which a course is used. Providers' own conceptions of learning will be apparent, whether deliberately or not. Unfortunately, not all employers and trainers involved in providing open learning courses will themselves have sophisticated conceptions of learning conducive to meaningful learning. (See Boot and Hodgson's distinction between 'dissemination' and 'development' conceptions of training amongst trainers, 1987.) One of the practical outcomes of this project has been an attempt to educate the providers of open learning through a series of guidelines (Strang and Sagar, 1986), and through various training workshops on open learning.

#### *Operationalising conceptions of learning*

Once again an interpretation is proposed which combines a personal and situational aspect to learners' approaches. The procedural steps suggest that learners have access to a range of study skills which are personal to them, but that the particular skills used depend upon the situation. The greater the variety, and the more sophisticated the range of study skills to which a learner has access, the more successful he is likely to be in operationalising his conceptions of learning.

This analysis demonstrates that a lack of study skills can indeed be a barrier to effective learning as was suggested at the very beginning of this project. Therefore study skills training could be valuable to learners as long as it was provided in the context of all the other procedural steps. As tools, study skills are only useful to learners who understand the nature of the task for which they are to use the tools.

### *Learning outcome*

In exploring the characteristics of meaningful learning, it has been suggested that true meaningful learning can only be evaluated by the learner himself. The fulfilment of a learning need is an essentially private experience. Yet it is likely that many learners do not expect to evaluate their own learning - it was difficult to find explicit examples of self-evaluated learning amongst the learners in study 2. This suggests that learners themselves need encouragement and guidance on how to evaluate their learning against their own idiosyncratic versions of the task demands.

In the context of the Open Tech, providers will also have goals in providing the learning opportunity. They will therefore have a legitimate interest in measuring learning outcome. The problem is that any assessment will have a significant influence on the learners' perceptions of task demands, and so, in turn, on learners' approaches. For example, in study 1 it appeared that course assessments demanded a lot of factual recall. The result was that learners predominantly adopted a surface approach to studying. In this example the assessments were not appropriate to the provider's own goals of improving technical competence. Technicians tend to be required to apply their expertise in problem-solving situations. Assessments should be designed to reflect this context. For example, an interactive computer simulation of an electrical problem could be designed, incorporating decision points in which the trainee would select an option leading to new information and a fresh decision. If assessments are designed to give rise to the same task demands as the situations in which a learner is required to use his

learning, then they are more likely to promote intrinsic interest and therefore meaningful learning.

### **Learner autonomy in the Open Tech**

A consideration of the nature of learning in the Open Tech has brought the discussion back to its roots by concluding that, for learning to be effective, it must have the qualities of learner autonomy. In chapter 1 the concerns of open learning were outlined as, seeking to provide learning opportunities which are free from external constraints. Courses should be learner-centred rather than provider-centred in their design, acknowledging the learner as an independent, intentioned being with his own individual goals and constraints. Open learning implies a degree of learner autonomy. Thus, in theory, open learning courses should provide the ideal context for effective learning. The danger is that in practice the 'freedom from constraints' is only operational at a superficial level. The truly radical learner-centred philosophy underpinning the concept of open learning is not necessarily fully appreciated by those responsible for the design and implementation of open learning systems. There is a temptation for employers, in particular, to see open learning as a convenient and cheap way of delivering training. As a result, most of the more fundamental psychological barriers are still fully potent in inhibiting effective learning. The model implies that technician learning in the Open Tech will only be effective if learners are allowed to interact with learning tasks in pursuit of their own intentions.

The issue is partially one of control. It is necessary for providers to relinquish some of their control into the hands of learners. However, not only is it important that learners are *free* to pursue their own intentions, but also that they are *able* to pursue their own intentions. If external constraints and controls over the learning process are removed, and yet the learner himself is not equipped to take over the control, then the result is not autonomous learning but anarchy - the absence of

order. In both studies there was evidence of learners who were inhibited from progressing successfully through the procedural steps by a belief that they could do nothing to improve their learning. They were described as having an 'external locus of control' with regard to learning. It was observed that an individual might normally be quite confident to take responsibility for his own actions, and yet abdicate such responsibility in formal learning situations. For open learning to be successful it must *enable* learners to *become* autonomous.

It can now be seen that throughout, this research has been concerned with the idea and process of learner autonomy. A basic assumption of the research stated in chapter 3 claims that learning is a fundamental characteristic of human nature. In other words, learning comes naturally to a human being, without need of support or encouragement. Furthermore, it has been concluded that the ideal, most effective learning is characterised by learner autonomy. Yet the studies which are reported imply that most learners fail to learn effectively; they are inhibited by various psychological barriers. The paradox arises: how is it that man - a natural learner - fails to learn naturally?

The resolution can be found in the nature of the learning investigated in this study. The Open Tech provides a formal learning situation, and as such must be seen as primarily governed by social rules (see chapter 3, pages 73-74). It must be these socially learned rules which are inhibiting natural learning behaviour. The hypothesis is illustrated by a comparison between a toddler and an adult. The toddler is a relatively unsocialised individual who is obviously a successful, and natural learner. In contrast, it is the highly socialised adult who reports experiencing difficulty in learning. In fact, like toddlers, adults are also constantly learning new things. In elaborating the multi-dimensional model it was observed that as individuals tackle the problems of every day life meaningful learning will occur which will relate to what is of intrinsic interest to the learner. The problem seems to be that, as they become socialised, individuals learn to attach meanings to the notion of learning which are counterproductive and inhibit natural learning behaviour. Perhaps future research could explore this hypothesis by

documenting the development of a child's conceptions of learning. If the ways in which man's natural learning autonomy becomes inhibited could be identified, then this might, in turn, provide insights into how it could be released.

The research now completed has looked at the processes of effective learning in the particular context of the Open Tech. It does not claim to describe learning in other contexts, but has provided a model from which implications about good practice in open learning for technicians might be drawn. Therefore it is hoped that the outcomes of this work will at least contribute to the successful learning of some technician learners in the Open Tech, and perhaps, in a small way, to the general foundation of understanding on which future learning theory will be built.



## REFERENCES

- Argyle, M. (1979) Sequences in social behaviour as a function of the situation, In, Ginsburg, G.P.(ed.) *Emerging Strategies in Social Psychological Research*, John Wiley & Sons.
- Backman, C.W. (1979) Epilogue : A new paradigm? In, Ginsburg, G.P.(ed.) *Emerging Strategies in Social Psychological Research*, John Wiley & Sons.
- Beaty, E. (1978) The student study contract, Paper presented at the 4th *International Conference on Higher Education*, University of Lancaster.
- Becker H.S.; Geer, B. & Hughes, E.C. (1968) *Making the grade: The academic side of college life*, John Wiley & Sons Inc.
- Belbin, E.; Downs, S. & Perry, P. (1981) *How do I Learn ? Project Report*, FEU.
- Belbin, R.M. & Belbin, E. (1972) *Problems in Adult Retraining*, Heinemann: London.
- Bennett, S.M. (1978) Recent research on teaching: A dream, a belief, and a model, *Br. J. educ. Psychol.*, 48, 127-147.
- Bernstein, B. (1974) Sociology and sociology of education : a brief account, In, Rex, J.(ed.) *Approaches to Sociology : An Introduction to Major Trends in British Sociology*, Routledge and Kegan Paul, London.
- Biggs, J.B. (1970) Faculty patterns in study behaviour, *Australian J. Psychol.*, 22, 161-174.

- Biggs, J.B. (1978) Individual and group differences in study processes, *Br. J. educ. Psychol.*, 48, 266-279.
- Biggs, J.B. (1979) Individual differences in study processes and the quality of learning outcomes, *Higher Ed.*, 8, 381-394.
- Biggs, J.B. (1985) The role of metalearning in study processes, *Br. J. educ. Psychol.*, 55, 185-212.
- Biggs, J.B. & Collis, K.F. (1982) *Evaluating the Quality of Learning. The SOLO Taxonomy (Structure of the Observed Learning Outcome)*, Academic Press, London.
- Bloom, B.S. (1976) *Human Characteristics and School Learning*, New York: McGraw-Hill.
- Bloom, B.S.; Englehart, M.B.; Frost, E.J.; Hill, W.H. & Krathwohl, D.R. (1956) *Taxonomy of Educational Objectives. The Classification of Educational Goals. Handbook 1 - Cognitive Domain*, Longmans Green, New York.
- Bogdan, R. & Taylor, S.J. (1975) *Introduction to Qualitative Research Methods*, John Wiley & Sons.
- Boot, R.L. & Hodgson, V.E. (1987) Open learning: Meaning and experience, In, Hodgson, V.E., Mann, S.J. & Snell, R. (eds.) *Beyond Distance Teaching - Towards Open Learning*, Society for Research into Higher Education & Open University Press.
- Bown, L. (1986) Motivation in Adult Education, Paper presented at the *Standing Conference of Studies in Education*, Kings College, London.
- Bradley, F.H. (1908) *Appearance and Reality*, New York, Macmillan.

- Bransford, J.D. (1981) Cognition and Adaptation: The importance of learning to learn, In, Harvey, J.H.(ed.) *Cognition, Social Behaviour and the Environment*, LEA.
- Bransford, J.; Sherwood, R.; Vye, M. & Rieser, J. (1986) Teaching Thinking and Problem Solving, *American Psychol.*, 41, 1078-1089.
- Brew, A. (1981) Underlying themes in study methods teaching, Paper presented at the *5th International Conference on Higher Education*, University of Lancaster.
- Brew, A. & Batten, M.A. (1981) Levels of thinking and Open University study, *Teaching at a Distance*, No. 20, 29-36.
- Brew, A. & McCormick, R. (1979) Student learning and an independent study course, *Higher Ed.*, 8, 429-442.
- Brown, A.L. Campione, J.C. & Day, J.D. (1981) Learning to learn: On training students to learn from texts, *Educational Researcher*, 10, 14-21.
- Bruner, J.S.; Goodnow, J.S. & Austin, G.A. (1956) *A Study of Thinking*, Wiley.
- Bugelski, B.R. (1970) Practical applications of Mowrer's theory, In, Clarizio, H.F.; Craig, R.C. & Mehrens, W.A. (eds.), *Contemporary Issues in Educational Psychology*, Michigan State University, Allyn & Bacon Inc., Boston.
- Buzan, A. (1974) *Use Your Head*, Ariel Publications, BBC.
- Carroll, J.B. (1963) A model of school learning, *Teachers' College Record*, 64, 723-733.
- Claxton, G. (1984) *Live and Learn. An Introduction to the Psychology of Growth and Change in Everyday Life*, Harper and Row.

- Coffey, J. (1977)** Open learning opportunities for mature students, In, Davies, T.C. *Open Learning Systems for Mature Students*, Working Paper 14, CET.
- Cohen, L., & Manion, L. (1985)** *Research Methods in Education*, 2nd. Edition. Croom Helm.
- Coles, C.R. & Fleming, W.G. (1978)** Understanding Learning: A case study in student and staff development, In, Brook, D. & Race, P. (eds.) *Educational Technology in a Changing World. Aspects of Educational Technology*, X11, 361-366.
- Da Costa, M. (1979)** Profile of a study skills workshop, In, Hills, P.J. (ed.) *Study Courses and Counselling*, Society for Research into Higher Education.
- Dahlgren, L.O. (1978)** Qualitative differences in conceptions of basic principles in Economics - A contribution to discussion of the validity of examination results, Paper presented at the *4th International Conference on Higher Education*, University of Lancaster.
- Dansereau, D.F.; Collins, K.W.; McDonald, B.A.; Holley, C.D.; Garland, T.; Diekhoff, G. & Evans, S.H. (1979)** Development and evaluation of a learning strategy training programme, *Jnl. educ. Psychol.* 71, 64-73.
- Descartes, (1642)** Second Meditation, In, Anscombe, E. & Geach, P.T. (eds.) *Descartes. Philosophical Writings*, Nelson's University Paperbacks. 1954.
- Downs, S. & Perry, P. (1982)** Research report: How do I learn? *Jnl. European Indust. Trng.*, 6, 27-32.
- Dweck, C.S. (1986)** Motivational processes affecting learning, *Amer. Psychol.*, 41, 10, 1040-1048.

- Elton, L.R.B., Hodgson, V. & O'Connell, S. (1979)** Study counselling at the University of Surrey, In, Hills, P.J. (ed.) *Study Courses and Counselling*, Society for Research into Higher Education.
- Entwistle, N.J. (1981)** *Styles of Learning and Teaching*, John Wiley & Sons.
- Entwistle, N.J. (1984)** Contrasting perspectives on learning, In Marton, F.; Hounsell, D. & Entwistle, N.J. (eds.) *The Experience of Learning*, Scottish Academic Press.
- Entwistle, N.J. (1987)** Motivation to learn: Conceptualisations and practicalities, *Br. J. educ. studies*, XXXV, 2, 129-148.
- Entwistle, N.J.; Hanley, M. & Hounsell, D.J. (1979)** Identifying distinctive approaches to studying, *Higher Ed.*, 8, 365-380.
- Entwistle, N.J. & Ramsden, P. (1983)** *Understanding Student Learning*, London; Croom Helm.
- Entwistle, N.J. & Wilson, J.D. (1977)** *Degrees of Excellence: The Academic Achievement Game*, Hodder & Stoughton, London.
- Ericsson, K.A. & Simon H.A. (1980)** Verbal reports as data, *Psych. Rev.*, 87, 3, 215-251.
- Fleming, V.G. (1986)** The interview: a neglected issue in research on student learning, *Higher Ed.*, 15, 547-563.
- Fransson, A. (1977)** On qualitative differences in learning. IV - Effects of motivation and test anxiety on process and outcome, *Br. J. educ. Psychol.*, 47, 244-257.
- Garfield, L. & McHugh, E.A. (1978)** Learning Counselling: A higher education student support service, *Jnl. Higher educ.*, 49, 382-392.

- Gibbs, G. (1981) *Teaching Students to Learn. A student-centred approach*, OUP, Milton Keynes.
- Glaser, B.G. & Strauss, A.L. (1967) *The Discovery of Grounded Theory. Strategies for qualitative research*, New York: Aldine.
- Harre, R. & Secord, P.F. (1972) *The Explanation of Social Behaviour*, Oxford, Basil Blackwell.
- Hills, P.J. & Potter, F.W. (1979) Group counselling and study skills, In, Hills, P.J. (ed.) *Study Courses and Counselling*, Society for Research into Higher Education.
- Hudson, L. (1968) *Frames of Mind*, Methuen, London.
- Kelly, G.A. (1955) *The Psychology of Personal Constructs*, Vols. 1 & 2 Norton, New York.
- Knowles, M.S. (1986) *Using Learning Contracts*, Jossey-Bass, San Francisco, London.
- Laurillard, D. (1978) A study of the relationship between some cognitive and contextual factors in student learning, *Unpublished PhD thesis*, University of Surrey.
- Laurillard, D. (1979) The processes of student learning, *Higher Ed.*, 8, 395-410.
- Laurillard, D. (1984) Learning from problem-solving, In, Marton, F.; Hounsell, D. & Entwistle, N.J. (eds.) *The Experience of Learning*, Scottish Academic Press, 124-143.
- Lewis, R. & Spencer, D. (1986) *What is Open Learning?* Open Learning Guide 4, Council for Educational Technology, London.

- Mann, L. (1979)** *On the trail of process: A historical perspective on cognitive processes and their training*, Grune & Stratton, New York.
- Manpower Services Commission (1981)** *An 'Open Tech' Programme*, A Consultative Document, MSC, Sheffield.
- Manpower Services Commission (1984)** *A New Training Initiative*, MSC, Sheffield
- Marton, F. (1981)** Phenomenography - describing conceptions of the world around us, *Instructional Science*, 10, 177-200.
- Marton, F. (1983)** Beyond individual differences, *Educational Psychol.*, 3, 3 & 4, 289-302.
- Marton, F.; Hounsell, D. & Entwistle, N.J. (1984)** *The Experience of Learning*, Scottish Academic Press.
- Marton, F. & Saljo, R. (1976a)** On qualitative differences in learning. I - Outcome and process, *Br. J. educ. Psychol.*, 46, 4-11.
- Marton, F. & Saljo, R. (1976b)** On qualitative differences in learning. II - Outcome as a function of the learner's conception of the task, *Br. J. educ. Psychol.*, 46, 115-127.
- Marton, F. & Saljo, R. (1979)** Learning in the learner's perspective. III - Level of difficulty seen as a relationship between the reader and the text, *Report from the University of Gothenburg*, No 78.
- Marton, F. & Saljo, R. (1984)** Approaches to learning, In, Marton, F.; Hounsell, D. & Entwistle, N.J. (eds.) *The Experience of Learning*, Scottish Academic Press, 36-55.
- Marton, F. & Svensson, L. (1979)** Conceptions of research in student learning, *Higher Ed.*, 8, 471-486.

- Merton, R.K. & Kendall, P.L. (1946)** The focused interview, *Amer. J. Sociology*, 5, 541-557.
- Morgan, A.; Taylor, E. & Gibbe, G. (1982)** Variations in students' approaches to studying, *Br. J. educ. Technology*, 13, 2, 107-113.
- Morris, A. (1984)** Focus in students in open learning systems, In, Snow, K. (ed.) *Aspects of Educational Technology XVII*, Kogan Page.
- Miles, M.B. & Huberman, A.M. (1984)** *Qualitative Data Analysis for Educational Research*, Croom Helm, London and Canberra.
- Miller, C. & Parlett, M.R. (1974)** *Up to the mark: A study of the examination game*, Soc. for Res. into Higher Ed., London.
- Misbet, J. (1979)** Beyond the study method manual, In, Hills, P.J. (ed.) *Study Courses and Counselling*, Soc. for Res. into Higher Ed., London.
- Misbett, R.E. & Wilson, T.D. (1977)** Telling more than we can know: Verbal reports on mental processes, *Psychol. Rev.*, 84, 231-259.
- Odell, R. (1980)** *Telcommunication Systems 1. Technician Education Certificate in Telecommunications - A complete learning package*, British Telecomm, Education and Training Division, Stone.
- Parlett, M.R. (1970)** The Syllabus-bound student, In, Hudson, L. (ed.) *Ecology of Human Intelligence*, 272-283.
- Pask, G. (1976)** Styles and strategies of learning, *Br. J. educ. Psychol.*, 46, 128-148.
- Pask, G. & Scott, B.C.E. (1972)** Learning strategies and individual competence, *Int. J. Man-machine Stud.*, 4, 217-253.
- Perry, W.G. (1970)** *Forms of Intellectual and Ethical Development in the the College Years: A Scheme*, Holt Rinehart & Winston, New York.



- Piaget, J. (1954) *The Construction of Reality in the Child*, Basic Books.
- Ramsden, P. (1979) Student learning and perceptions of the academic environment, *Higher Ed.*, 8, 411-428.
- Roberts, D. (1986) Student study patterns, *Open Learning*, November 1986, 34-37.
- Rogers, C.R. (1969) *Freedom to Learn*, Merrill, Columbus, Ohio.
- Rogers, J. (1971) *Adults Learning*, Open University Press, Milton Keynes, Philadelphia.
- Roueche, J.E. & Snow, J.J. (1977) *Overcoming Learning Problems: A Guide to Developmental Education in College*, San Francisco, Jossey-Bass.
- Russell, B. (1967) *The Problems of Philosophy*, Opus 18, Oxford University Press.
- Sagar, E.I. & Strang, A.B. (1985) *The Student Experience. A case study of technicians in open learning*, Roffey Park Management College, Horsham, Sussex. Crown Copyright.
- Saljo, R. (1979a) *Learning in the Learner's Perspective I. Some Common Sense Conceptions*, Reports from the Institute of Education, University of Gothenburg, No. 76.
- Saljo, R. (1979b) Learning about learning, *Higher Ed.*, 8, 443-451.
- Shanley, A. (1986) Maintaining student motivation, *Adult Education*, 59, 51-53.
- Silviera, J.M. (1972) Incubation: The effects of interruption timing and length on problem solution and quality of problem processing, (Doctoral dissertation, Univ. of Oregon, 1971), In, *Dissertation Abstracts International*, 32, 5500B (Univ. microfilms, No. 72-9, 560).

- Snow, R.E. (1973)** Theory construction for research on teaching, In, Travers, R.M.W. (ed.), *Second Handbook of Research on Teaching. A Project of the American Research Association*, Rand McNally & Co., Chicago.
- Spencer, D.C. (1980)** *Thinking about Open Learning Systems*, Working Paper No. 19, Council for Educational Technology, London.
- Stainton Rogers, W. (1986)** Changing attitudes through distance learning, *Open Learning*, November 1986, 12-17.
- Sternberg, R.J.; Ketron, J.L. & Powell, J.S. (1982)** Componential approaches to the training of intelligent performance, In, Detterman, D.K. & Sternberg, R.J. (eds.) *How and how much can intelligence be increased*, Ablex Publishing Corporation, New Jersey.
- Strang, A.B. & Sagar, E.I. (1986)** Using the learners' perspective - Guidelines for those involved in managing, materials design and learner support in open learning, In, Strang, A.B. & Sagar, E.I., *Open learning in Action: How to provide effective open learning programmes*, National Extension College, Cambridge.
- Svensson, L. (1977)** On qualitative differences in learning III - Study skill and learning, *Br. J. educ. Psych.*, 47, 233-243.
- Tavistock Institute of Human Relations (1987)** *The Open Tech Programme Development Review, Final Report*, Employment Policy and Vocational Training Research Series, Crown Copyright.
- Taylor, E.; Morgan, A. & Gibbs, G. (1981)** The 'Orientation' of Open University foundation students to their studies, *Teaching at a Distance*, No. 20, 3-12.
- Technician Education Council (1980)** *A Guide to TEC*, TEC.

- Thomas, L.F. & Harri-Augstein, E.S. (1977)** Learning to learn: The personal construction and exchange of meaning, In, Howe, M.J. (ed.) *Adult Learning. Psychological Research and Applications*, John Wiley & Sons.
- Thomas, L.F. & Harri-Austein, E.S. (1985)** *Self-organised learning. Foundations for a conversational science for psychology*, Routledge & Kegan Paul.
- Tolley, G. (1983)** The Open Tech: Why, what and how? Paper presented at the AGM of the *Association of Colleges for Further and Higher Education*.
- van Rossum, E.J.; Deijkers, R. & Hamer, R. (1985)** Students' learning conceptions and their interpretation of significant educational concepts, *Higher Ed.*, 14, 617-641.
- Weber, M. (1968)** *Economy and society*, 3 vols. Guenther Roth & Claus Wittich (eds.), New York, Bedminster.
- Weins, V. (1983)** Metacognition and the adult passive learner, *Jnl. of Learning Disabilities*, 16, 144-149.
- Welford, A.T. (1962)** Slowing with Age, In, Chown, S.M. (ed.) *Human Ageing*, Penguin Books.
- White, P.A. (1988)** Knowing more about what we can tell: 'Introspective access' and causal report accuracy 10 years later, *Br. J. Psychol.*, 79, 13-45.
- Witkin, H.A.; Moore, C.A.; Goodenough, D.R. & Cox, P.W. (1977)** Field-dependent and field-independent cognitive styles and their educational implications, *Rev. educ. Res.*, 47, 1-64.
- Yerkes, R.M. & Dodson, J.D. (1908)** The relation of strength of stimulus to rapidity of habit formation, *J. Neurol. Psychol.*, 18, 459-482.

## LIST OF APPENDICES

	<i>PAGE NO.</i>
1. Sample segment from <i>Telecommunications Systems I</i> .....	277
2. Study 1: Learning task materials.....	284
3. Study 1: Interview schedule.....	290
4. Quantitative test A.....	297
5. Rationale underlying interview questions for study 1...	298
6. Study 1: Introductory letter to students.....	301
7. Quality of learning outcome, Measure A Definition of categories.....	302
8. Quality of learning outcome, Measure B Developing a scoring system.....	305
9. Examples from the data of study 1 illustrating the categories of Biggs' SOLO taxonomy.....	309
10. Quantitative test B.....	312
11. Analysis of learners' interpretations of the demands of the experimental learning task.....	313
12. Study 2: Interview schedule.....	316
13. <i>Secrets of Success</i> . A counselling tool for open learners.....	330
14. Table of all category data for study 1.....	335

# Telecommunications Systems I

TEC U76/007

SECTION: A

SEGMENT: 6

OBJECTIVE: 1.2 1.6

LAST TOPIC:

Radar; Data Transmission.



THIS TOPIC:

Types of Electrical Signals;  
 Direct Current d.c. Signals;  
 Alternating Current a.c. Signals.



NEXT TOPIC:

Some practical application and  
 limitations of d.c. signals.

CONTENTS:

TEXT	600 WORDS	PRACTICAL	-
FIGURES	5	SAQ	2
AUDIOTAPE	-	ANSWERS	2
EXAMPLES	-	OTHER	-
SUMMARY	90 WORDS		

Issue 2, September 1978

## TYPES OF ELECTRICAL SIGNALS

### Introduction

In any discussion of electricity it is important to be clear about what happens when electricity flows through a wire, and the factors which can influence that flow. There are three basic ideas to be considered.

- (a) An *electric current* is the flow of electricity along a wire or around a circuit. Current is measured in *amperes*, often abbreviated to "amps".
- (b) *Resistance*. This is the property of a substance to impede (or resist) the flow of electricity through it. Resistance is measured in *ohms*.
- (c) *Electro-motive force* (e.m.f.). *Potential difference* (p.d.) *Voltage* (V). These are all terms which may be used to denote the electrical "*pressure*" which, when applied to a circuit causes the current to flow in that circuit. The unit is the *volt*.

These ideas are discussed more fully in courses dealing with electrical principles, and if you want a more detailed discussion you should refer to a relevant textbook.

For the purposes of this course it is only necessary to consider these ideas as far as they influence the use of electricity in information transmission. Electrical signals fall into two broad categories:

- (a) Direct Current (d.c.) Signals.
- (b) Alternating Current (a.c.) Signals.

The circuit supply voltage of a d.c. signal has constant polarity, (that is, it does not oscillate from positive to negative, it is either one or the other). The current always flows in the same direction.

Fig. A.25 is a graph of the voltage between x and y over a period of time, in a circuit like that drawn in Fig. A.24, when switched on.

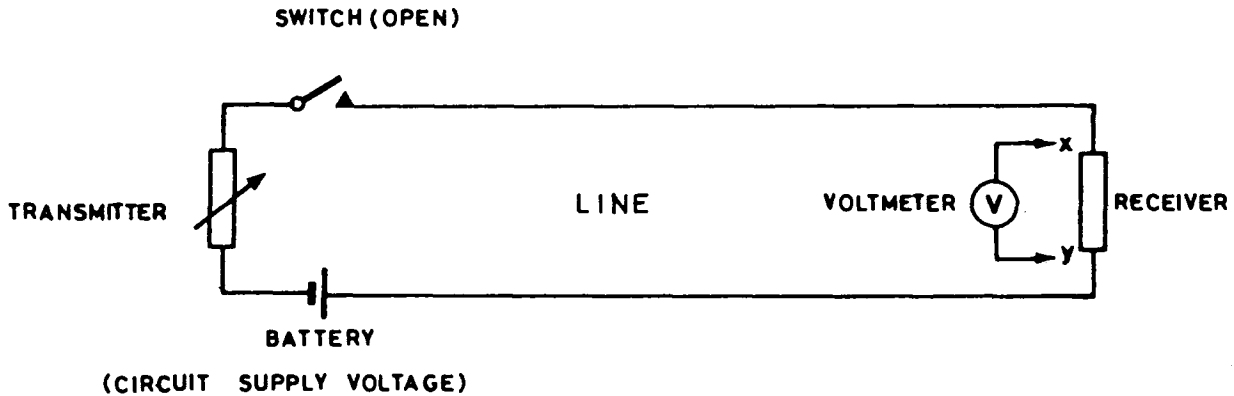

R 55023

Fig. A.24

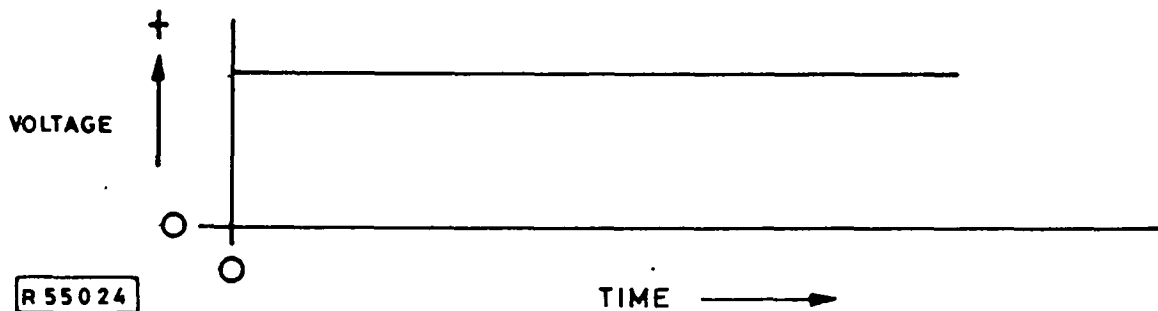

R 55024

Fig. A.25

In Fig. A.25 the voltage is given as positive for convenience. Whether the voltage is read as positive or negative depends both on the polarity of the supply voltage and the connexions of the meter used to measure the voltage. The important point in d.c. working is that the supply voltage does not change in polarity. Fig. A.26 is another graph showing the voltage between y and x. Such a measurement would arise if the polarity of the supply voltage in Fig. A.24 were reversed.

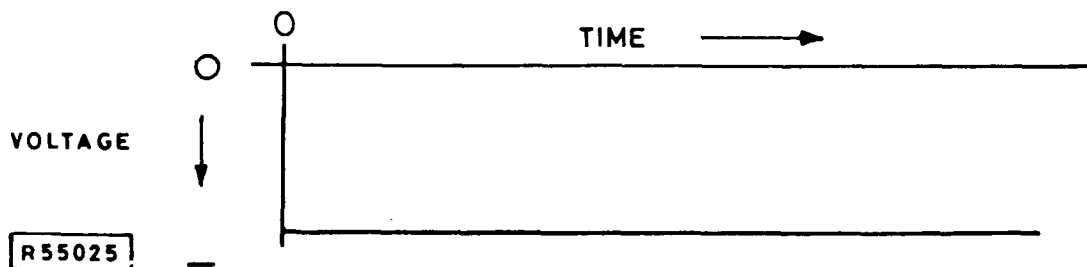

R 55025

Fig. A.26

In an alternating current signal the voltage constantly alternates between positive and negative. The most elementary form of an a.c. signal produces a *sine-wave* form when plotted against time. See Fig. A.27.

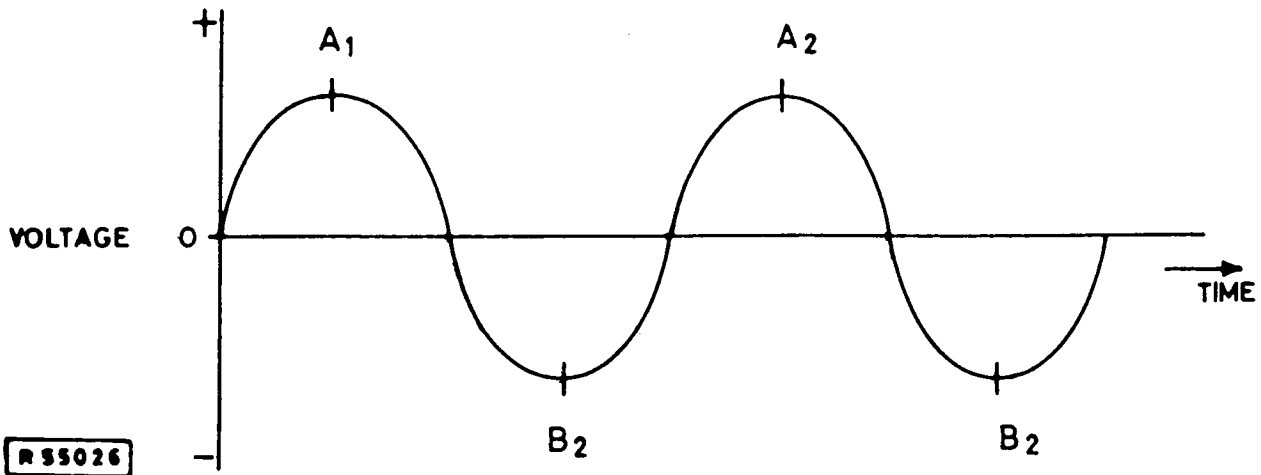

Fig. A.27

This characteristic shape is derived from the method by which alternating current is generated. In its simplest form this can be explained as follows. If a loop of wire is rotated in a uniform magnetic field an alternating e.m.f. will be generated within the loop. See Fig. A.28.

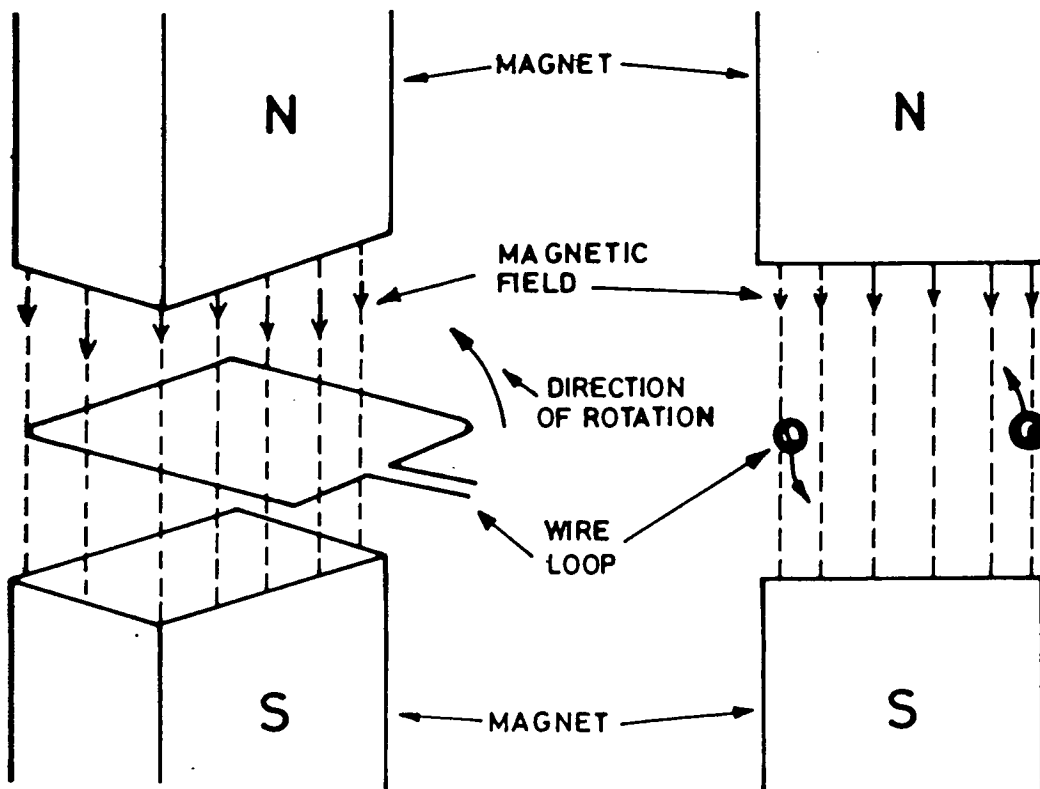

Fig. A.28

As the wire rotates it will be constantly changing its position relative to the magnetic field between the north and south poles of the magnet. The result of the wire loop rotating in the magnetic field is to induce into the loop an e.m.f. whose value and polarity vary as the movement of the loop with respect to the magnetic field varies. The distance between  $A_1$  and  $A_2$  or  $B_1$  and  $B_2$  on the sine-wave shown in Fig. A.27 represents one complete revolution of the generator. With each revolution the value of the e.m.f. alternates between a certain *positive* and *negative* value.



The following is a list of the main points from Segment A.6.

There are two fundamental types of electrical signals, namely:

1. ***The Direct Current (d.c.) signal.*** With this signal the direction of the current flowing in the circuit is constant and is determined by the polarity of the circuit supply voltage.
2. ***The Alternating Current (a.c.) signal.*** In an a.c. signal the polarity of the voltage constantly alternates between positive and negative so causing the value and direction of the circuit current to be perpetually changing.

Now attempt the following SAQs, putting your answers in the spaces provided.

**SAQ A10**

Draw a graph of current against time for a typical direct current (d.c.) signal.

**SAQ A11**

Draw a graph of current against time for a typical alternating current (a.c.) signal.

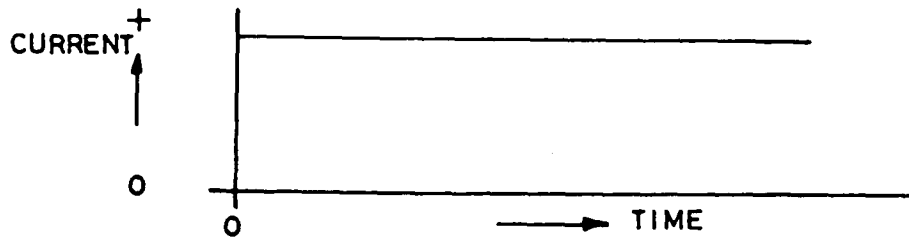

R 55028

Fig. A.29

SAQ A11 Answer

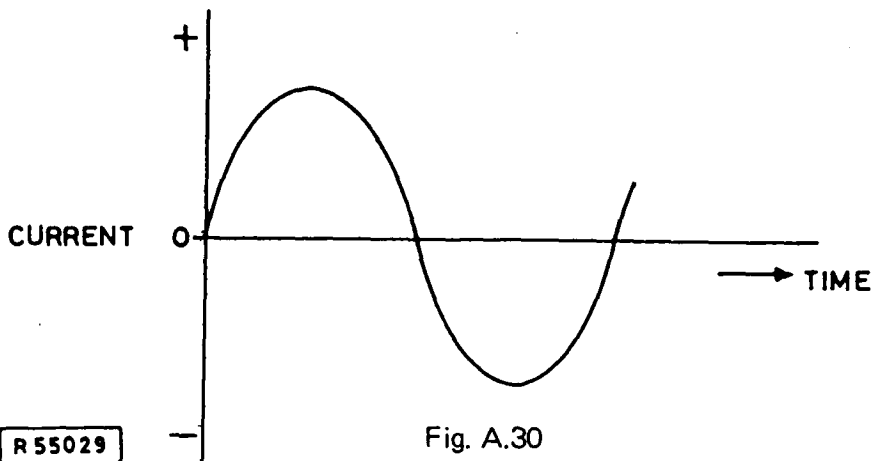

R 55029

Fig. A.30

Telecommunications Systems I

Interviews with students

Attached is an extract from the course materials which you will be studying later in the course. It is part of a segment about computers and it is self-explanatory.

INSTRUCTION

- a) Please read the extract through and learn it.
- b) Take as long as you like and when you have finished give the extract back to the interviewer.
- c) Pencil and paper are attached if you should need them.

# Telecommunications Systems I

TEC U76/007

SECTION: F

SEGMENT: 3

OBJECTIVE: 12.1, 12.6

LAST TOPIC:

What are Computers?  
 Comparison of Analogue and Digital Computers  
 Advantages and Disadvantages of Computers



THIS TOPIC:

How Computers Process Information



NEXT TOPIC:

A Computer Programme  
 What happens in a Calculation?  
 On-line, Off-line, Interface and time-sharing

CONTENTS:

TEXT	620 WORDS	PRACTICAL	
FIGURES	3	SAQ	1
AUDIOTAPE		ANSWERS	1
EXAMPLES		OTHER Fig. F.10 is a Visual Aid	
SUMMARY	102 WORDS		

Issue 2, September 1978

## HOW COMPUTERS PROCESS INFORMATION

In this and subsequent segments discussion will be restricted to the subject of digital computers. Analogue computers tend to be much more specialised and consequently are far fewer in number than digital computers.

### Why Use Codes?

The human being is able to understand information given to it in many forms, speech, pictures, handwriting, and expressed in a very large variety of ways. The computer cannot do this and therefore information has to be presented to it in a form it can understand, that is by a number or letter code.

The code is normally recorded onto cards, paper tape or magnetic tape. (There are other ways of presenting the codes to a computer and these will be discussed in Segment 5). On paper tape or cards the code is recorded in the form of small holes punched in special patterns each indicating an item of information. See Fig. F.10.

On magnetic tape the code is recorded as small magnetised spots arranged in patterns similar to those found on paper tape and card. Magnetic tape, unlike card or paper can be reused when the material coded on the tape becomes out of date.

Reading the codes is a fairly simple process and there are a number of systems in use. One method of reading the code from punched card or tape is to pass the card over a light source. The light passes through the perforations in the card as brief flashes which are in turn converted into electrical pulses by light sensitive cells.

Whatever method is used to read the code the digital signals pass into the computer as a series of electrical *pulses* and *no pulses*. The sequence and arrangement of these makes up the information the computer has to deal with.

### Figure 10 – Visual Aid

Fig. F.10 is a visual aid comprising of a punched paper card and a small piece of punched paper tape. It should be included with this segment.

One of the most important functions of a digital computer is to perform arithmetic operations on numbers. To do this numbers must be represented by electrical signals.

The electrical signals used in computers have two stable states, that is *on* or *off*. Expressed in other terms *current* or *no current*, pulse or no pulse. Each of these two states is equally important. Fig. F.11 gives some idea of the relationship between a coded signal, and the electrical pulses it produces in the computer.

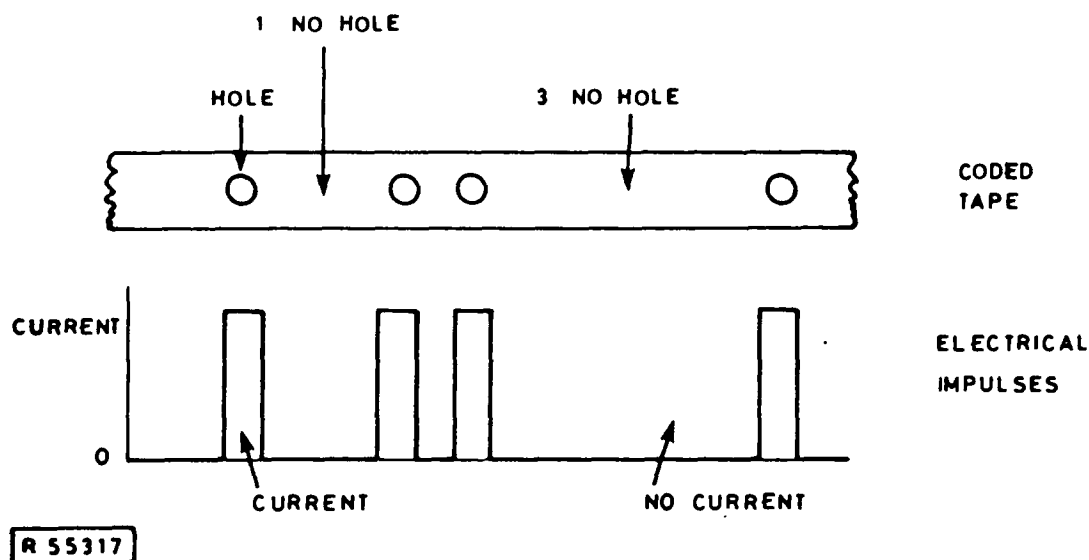

A section of paper tape coded with a sequence of 'holes' and 'no holes', and the corresponding impulses produced in a computer when the tape is 'read'.

Fig. F.11

This two state nature of electrical devices can be used to represent the two characters of the binary numbering system 0 and 1. Fig. F.12 shows an arrangement of representing the decimal numbers 0–5. (Note if you want to learn more about binary arithmetic refer to a suitable mathematics textbook).

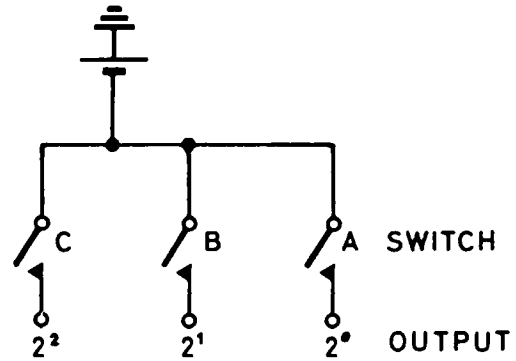

STATE OF SWITCHES	BINARY NUMBER			DECIMAL NUMBER
	C	B	A	
ALL SWITCHES OPEN	0	0	0	0
SWITCH A CLOSED	0	0	1	1
SWITCH B CLOSED	0	1	0	2
SWITCHES A & B CLOSED	0	1	1	3
SWITCH C CLOSED	1	0	0	4
SWITCHES C & A CLOSED	1	0	1	5

R 55318 A

Fig. F.12

Fig. F.12 shows an arrangement of switches A, B and C and the outputs produced by operating the switches in various combinations.



**Bits.**

A binary digit, that is 0 or 1, is referred to as a BIT, a word derived from Binary digIT. It is the smallest unit of information a computer can handle and corresponds with a single *pulse* or *no pulse* in an information signal.

## APPENDIX 3

### LEARNING TO LEARN AT A DISTANCE - OPEN TECH

#### Interview schedule

##### Introduction

##### Mention:

1. Expansion of technical courses for distance/correspondence students under Open Tech.
2. We have been asked to find out whether students already studying technical courses can teach us anything about how future courses should be run or written.
3. British Telecom are co-operating in this study; we will really appreciate your help in talking to us.
4. Nothing you say in this interview will get back to BT; all results will be confidential.
5. Would you mind if we have the tape-recorder on? The tape will provide a check on whether my notes of the interview are accurate.

##### A Questions on course in general

1. CAN YOU TELL ME PLEASE WHY YOU ARE STUDYING THIS COURSE?

X is perhaps your main reason for studying the course. Can you think of anything else you are getting out of it?

Would you be interested in studying the course if it was not necessary for promotion?

OR substitute other reason interviewee has given if it was not promotion.

2. TO WHAT EXTENT IS WHAT YOU ARE LEARNING ON THE COURSE HELPFUL IN YOUR DAILY WORK?

In your job as it is at present?

Do you think it would be necessary if you were promoted? i.e. would you use it on the job?

Which parts of the course are/would be relevant? How?

3. HAVE YOU STUDIED ANY BRITISH TELECOM COURSES BEFORE?

Which ones?

When?

How did that go?

What was good about it?

What was unsatisfactory, if anything?

A Questions on course in general (continued)

4. HOW DO YOU FEEL ABOUT THIS COURSE NOW YOU HAVE BEEN STUDYING FOR  
.....MONTHS?

Is the course going as you expected?

(Prompt if necessary: Pleased, interested, fed up? etc)

B Learning task - all questions and instructions in this section should be given exactly as written

I'd like now to ask you about the way you normally study the materials in Telecommunications Systems I. In order to help you think about that I am going to give you an extract from the course materials which you will be studying later in the course. It is part of a segment about computers and it is self-explanatory.

NOTE TO INTERVIEWER - If student expresses doubt about ability to follow material later on in course make it clear that following it does not depend on having studied other segments which come before it.

INSTRUCTION (Also to be written on a separate piece of paper and presented with the extract.)

- a) Please read this through and learn it.
- b) Take as long as you like, and when you have finished give the booklet back to me. Then I would like to ask you about it.
- c) Here is a pencil and paper if you should need them.

Post task

Collect learning task extract.

1. Question: In a minute I would like you to explain to me in your own words the main points which were made in the passage you have just read. Explain it as if I knew nothing about how computers process information.

Take your time in thinking about what you would say.

If you prefer you can write down your explanation.

2. Short answer questions: Here are a few short written questions, could you fill in the answers please?

N.B. Questions written on separate piece of paper to be handed to interviewee.

Relax atmosphere e.g. 'Thanks very much for your help', 'There will be nothing else in the interview that is like a test'.

3. WHEN I FIRST GAVE YOU THE BOOKLET ABOUT HOW A COMPUTER PROCESSES INFORMATION, I ASKED YOU TO READ IT THROUGH AND LEARN IT. WHAT DID YOU TAKE THE WORK LEARN TO MEAN?

Can you tell me how you actually set about that?

(If necessary) Were there any bits which you found it difficult to learn?  
How did you try to overcome this?

Did you try to memorise anything?

How did you decide what to memorise?

How did you try to memorise?

B Questions on Learning Task (Continued)

- 4 WHEN I ASKED YOU TO EXPLAIN THE BOOKLET TO ME, HOW DID YOU DECIDE WHAT TO PUT IN YOUR EXPLANATION?

C. Questions on learning on this B.T. course

Now let's talk about learning the 'Telecommunications System I' materials.

1. HOW MUCH TIME WOULD YOU SPEND STUDYING IN A NORMAL WEEK? (i.e. not the week before the Phase test!)
2. WHICH PARTS OF THE COURSE HAVE YOU FOUND IT EASIEST TO LEARN?

Did you know about this already?

Which parts of the course have you found most difficult to learn?

Have you any idea why?

3. I WOULD LIKE YOU TO TALK THROUGH WITH ME NOW HOW YOU WOULD LEARN A SINGLE SEGMENT/BOOKLET OF THE MATERIALS.

What do you do first of all.....?

(If necessary) How often do you answer the SAQ's (self assessment questions)

Do you find them helpful?

4. WHAT WAS YOUR LAST HOMEWORK ABOUT?

What did it ask you to do?

How did you set about doing it?

Prompt: Take me through the different stages..... First you.....?

C. Questions on learning on this BT course (continued)

5. HOW DO YOU FEEL ABOUT THE PHASE TEST THAT IS JUST COMING UP?

How have you prepared for it?

D. Closing Questions if time allows

1. WHAT ARE YOUR GENERAL REACTIONS TO DOING A CORRESPONDENCE COURSE?

Do you like it/dislike it?

Can you learn this way?

2. FINALLY, IF A CHILD SAY 10 or 11 ASKED YOU HOW A TELEPHONE WORKED; WHAT WOULD YOU SAY IN EXPLANATION?



Interview Schedule

Telecommunications Systems I

13

Written questions:

- 1) In computing, a code is
- a) Always numerical
  - b) A simple way of presenting information to a computer
  - c) One hole punched in a computer tape

Choose your answer from a, (b) and c

- 2) Name 3 ways of recording the code for the computer
- a) CARDS
  - b) PAPER TAPE
  - c) MAGNETIC TAPE

- 3) Name 3 ways of expressing the coded signal read by the computer
- a) ON/OFF
  - b) CURRENT OR NO CURRENT
  - c) PULSE OR NO PULSE.

- 4) What is a BIT?
- a) A digit?
  - b) The smallest unit of information a computer can process
  - c) A small piece of computer tape

Choose your answer from a, (b) and c

5A

## APPENDIX 5

### Rationale underlying interview questions for Study 1

#### Design of the interview schedule

In designing the interview schedule layout, the concern was to provide a document which interviewers could use and read easily with a learner present. It was important that interviewers could refer to the schedule for direction without interrupting the flow of conversation by pouring over densely packed text. Questions are therefore well spread out on the pages, also giving the opportunity for notes to be made on the same sheet if required.

Main questions are printed in capital letters, 'prompt' and/or 'probe' questions appear in lower case letters. The latter are provided to help interviewers probe a topic further or restate a question if the initial inquiry has not been particularly fruitful.

#### Section A: Questions on course in general

*Questions 1 and 2* are concerned with intentions at the macro level, relating to the TS1 course in general. They are guided by the work of Taylor et al.(1981) who have explored the relationship between Open University students' intentions and approaches to learning using Taylor's categories of learner 'Orientation'. It was intended that these questions would yield data on orientations enabling a comparison between Open Tech learners and the undergraduate learners previously studied. Probes were designed to help elicit the full range of learners' reasons for undertaking the course, and gauge which were the most important ones. Particular attention is given to job-related reasons because these are the reasons attributed to learners by course designers (apparent from discussion with staff at the BT Training College).

This particular topic was chosen to open the interview following the experiences of a colleague, Anita Morris, who had interviewed a similar population of learners in the context of a study on drop-out rates in open learning (Morris, 1984). Morris found that learners were very able and willing to discuss their reasons for studying. It also appeared that such questions would accord with learners' expectations of the interview and therefore help them to relax and feel comfortable in the situation.

*Question 3* This question explores learners' previous experiences of British Telecomm courses. It was intended that information given in response to this question be used to interpret and throw light on learners' reactions to studying TS1. It would give an indication of how experienced a student each individual was, and the nature of any previous experience in job-related training.

*Question 4* invites the learner to express global reactions to the course, which might perhaps later get lost in the detail of the discussion. It was also considered valuable to provide an opportunity at a fairly early

stage of the interview for the individual to raise any issues - either positive or negative - which he felt to be of paramount importance in considering his learning experiences. If any learner felt strongly about an issue, but did not feel that our questions enabled him to raise it, this might distract him from addressing the issues which the interview *did* raise.

### **Section B: Questions on the learning task**

*Questions 1 and 2* this section comprises the qualitative and quantitative measures of learning outcome just described.

*Question 3* directly addresses the issue of meaning, using the concrete example of the use of the word *learn* in the task instructions to find out how learners attempt to define the term. Such a *definition of learn* is seen as only valid within the context in which it was elicited. Answers to this question should at the same time give an indication of how learners interpreted the experimental learning task.

Probe or prompt questions aim to explore learners' approaches to tackling the learning task, including learning behaviour undertaken. There is a particular emphasis on memorisation because assessment appeared to demand mainly the recall and representation of material. Also, underlying this series of questions was a concern to find out about the frequency of use of specific study tactics such as might be taught on a conventional study skills course.

*Question 4* seeks to explore the learners' perception of the task designed to measure quality of learning outcome. The need for this is particularly highlighted by the work of Fransson on the differential effects of intrinsic and extrinsic motivation (Fransson, 1977). He found that the true motivational state of his subjects could only be established by reference to their perceptions of the task, and could not be assumed from the experimental condition to which he had assigned them.

### **Section C: Questions on learning on this BT course**

The previous section, Section B, of the interview explored approaches to learning using the experimental learning task as the focal experience. section C now does the same, but uses different aspects of normal studying of TS1 as the focal experience.

*Question 1* asks how long the learner spends studying during a normal week. 'Time on task' is a familiar variable in numerous models of school learning (Eg. Carroll, 1963; Bennett, 1978; Bloom, 1976 ) and therefore considered worthy of inclusion in this investigation. It was also of particular interest in following up the work of Svensson (1977) who was able to distinguish between less successful and more successful students using a simple algorithm based on the distinction between deep and surface-level processing and using a limited number of other variables including time spent studying.

*Question 2* focuses on easy and difficult aspects of studying seeking to open up global reactions to the course, starting from the affective and relating this to learners' accounts and explanations of their experiences.

*Question 3* together with the following probe questions is designed to elicit a complete account of the learner's 'normal' approach to studying a single segment of the materials. As has been demonstrated, such a segment would in fact be very similar in form to the learning task materials themselves, however the context of normal study would presumably be perceived differently.

A specific question is directed about the SAQ's because the design of these offers one clear opportunity for influencing perceived task demands which in turn according to Marton and Saljo (1976b) will effect level of processing. If the design of SAQ's could be used in improving effective learning it is important to understand the extent to which they are used by learners, and what attitude learners have to them.

*Question 4* like question 3 aims to elicit a complete account of the learner's approach to a particular study task; in this case, homework which is the only other routine task apart from studying the segments of learning materials demanded of learners on this course.

*Question 5* asks for both affective response and an account of the learner's approach to preparing for the phase test. Both aspects are important to give an indication of the learner's perceptions of the task demands of the phase test. The probe questions about approach to preparation aim to elicit another account of the learning process, thus providing further data to contrast with the earlier focal experiences.

#### **Section D: Closing questions if time allows**

*Question 1* asks learners to compare their experiences of this correspondence course with previous face-to-face courses which they have undertaken. Although the design of this study does not depend on emphasising the contrasts between distance learning and face-to-face courses, it is acknowledged that discussing the differences provides a further forum within which learners' intentions and meanings in learning may emerge. The question was therefore suggested for use when time was available - a circumstance most likely to occur where a learner had not been particularly forthcoming on other topics.

*Question 2* asks the learner to explain in simple terms how a telephone works, and is an alternative question for eliciting a measure of the individual's quality of understanding of a technical topic. Interviewer's were advised to use this question if for some reason the request for an explanation of the learning task material had failed to produce an appropriate response.



## APPENDIX 7

### Quality of learning outcome, Measure A

(Marton and Saljo model)

#### Definition of categories

##### LEVEL A:

- \* Computers only understand the two electrical states 'on' and 'off'.
- \* Therefore they can only receive information in coded form.
- \* They use the binary numbering system for coding numbers because this uses only '1' and '0' which can be directly converted into 'on' and 'off' pulses.

To qualify for this category learners must demonstrate an understanding of the three points listed above. They need not demonstrate a complete understanding of the binary numbering system so long as they appreciate why it is appropriate for use with computers (as outlined in the third point above).

## LEVEL B:

- \* Computers only understand the two electrical states 'on' and 'off'.
- \* Therefore they can only receive information in coded form.
- \* Binary numbers *may* be discussed as a characteristic of computer codes, but no understanding of the nature of the link between binary numbers and on/off pulses is demonstrated.

Level B differs from level A in that the learner does *not* demonstrate an appreciation that binary numbering is used in computing because it only uses '1' and '0' which can be directly converted into on/off pulses.

## LEVEL C:

- \* Computers can *only* understand information in coded form.
- \* The codes used by computers employ the two electrical states 'on' and 'off'.

At this level learners do not see the use of the two electrical states 'on' and 'off' as a determining feature dictating that computers must use coded information. Instead they see the use of on/off pulses as simply one characteristic of the codes which computers use. They may or may not discuss the use of the binary system, and may or may not appreciate the link between the use of '1' and '0' and the two electrical states of 'on' and 'off'.

**LEVEL D:**

- \* Computers can *only* understand information in coded form.
- \* Coded information is conveyed by use of paper tape, punch cards and/or magnetic tape.

At level D learners do appreciate that computers can only understand information in coded form. However although they may mention on/off pulses and/or binary numbering, they do not demonstrate an appreciation that these play an important role in the conveying of coded information. Instead there is an emphasis on the mechanics of the processes involved in using paper tape to convey codes.

**LEVEL E:**

- \* Computers process information by means of paper tape, punch cards and/or magnetic tape.

Level E differs importantly from level D in that learners do not demonstrate any understanding of the necessity of using coded information with computers. They simply describe the mechanics of the processes involved in feeding paper tape, punch cards and/or magnetic tape. They appear to consider these processes as the essence of the message.

**LEVEL F:**

Level F responses use information derived from the learning material, but without organising it into a form which attempts to describe how computers process information.



## APPENDIX 8

### Quality of learning outcome, Measure B (Conventional essay type)

#### Developing a scoring system

*The following instructions were given to a computer expert:  
(His responses have also been entered where appropriate.)*

Learners will be given marks out of a total possible score of 15 points. Their score should reflect their level of understanding within each of the sections A, B, and C; but also account for the different relative importance of each section in understanding the topic as a whole. (Eg. Section B on *How coded information is fed into the computer* is not so fundamental to the understanding of how computers process information as sections A and C.)

Therefore please decide on the relative importance of each section and establish a total number of points for each section which reflect their importance and add up to 15.

Section A total:	<input type="text" value="6.5"/>	points
Section B total:	<input type="text" value="3.5"/>	points
Section C total:	<input type="text" value="5"/>	points
Overall total:	<input type="text" value="15"/>	points

Now please allocate marks within each section from '0' to the maximum total decided for that section on the following pages:

PTO

Section A      Why computers need to use codes in order to process information.

Marks 

0
---

 No mention of why codes are needed.

2
---

 Mention that computers need coded information without explaining why.

3
---

 Explain that computers need to receive information in a specifically appropriate form, they can not receive it in varied forms like people.

65
----

 The only distinction which computers can recognise is that between the electrical states 'on' and 'off'.

Section B      How coded information is fed into a computer.

Marks 0 No mention of how coded information is fed into a computer.

0.5 { Mention that paper tape, punch cards and/or magnetic tape are used to convey information to a computer, without explaining how.

1 { Mention that either holes and/or magnetic spots are involved in the process without explaining how they function.

2 { *Either:* Mention that a light shines through the holes in paper tape or card, without mentioning the link with electrical pulses.  
*Or:* Link paper tape, cards and magnetic tape with electrical pulses, but without explaining how information on one is converted into the other.

2.5 { Explain that magnetic spots and punched holes correspond to codes without referring to electrical pulses.

3.5 { Explain correctly how magnetic spots and punched holes are converted into electrical signals.

Section C      The role of the binary numbering system

Marks 0 No mention of the binary numbering system.

1 { Mention either binary numbers or binary digits.

2 { Mention that there is a link between the binary system and the patterns of holes or magnetic spots.

3.5 { The binary system provides a way of expressing numbers in terms of patterns of on/off pulses. (Including either examples of the binary code for particular numbers - whether or not correct - or an explicit statement of the link.)

5 { In addition to the above, a demonstration of an understanding of the principle of binary numbering whether by stating it explicitly, or by giving a series of correct examples of the binary code for any denary numbers above 1.

## APPENDIX 9

### Examples from the data of study 1 illustrating the categories of Biggs' SOLO Taxonomy

Learners' explanations of the topic were found to fall within Biggs' category definitions with all but the least sophisticated, pre-structural, response represented. For example the response of learner 4 could be described as 'Uni-structural':

"I think the main point was the different two ways which ...paper tape or magnetic tape. Magnetic tape can be used again . Paper's got holes in it that can... Magnetic tape's got magnetic spots on it that can be wiped off like the paper can't."

(Learner 4, p1a)

Learner 4 demonstrates a grasp of only one idea from the learning materials, he has appreciated something of the mechanics of processing information using computers. However the explanation omits a number of aspects of the process covered by the learning materials; it does not succeed in explaining *how* paper tape or magnetic tape is used, and does not attempt to explain *why* they are necessary.

The account given by learner 21 is a little more complete justifying classification as a 'Multi-structural' response:

"Humans can learn things from pictures, reading and handwriting - information which a computer can't. That is, it uses numbers and most computers use the binary numbers 0 to 1. And instead of the information being written down its printed on the card with holes in it and you either have magnetic tape or cardboard card and through this tape light is shone. And this light shines through and it'll either go through holes and where there are no holes it won't go through. And this sorts out a code which is the binary system. And each digit is called a 'BIT'...

(Learner 21, p3)

Here the learner mentions most of the aspects covered by the learning materials. At first glance it may appear that he is relating the different concepts, but in fact he is simply stating that there are relationships rather than explaining their nature. The second half of his response is particularly characteristic of the 'multi-structural' response where he appears to be doing no more than listing statements which he remembers from the text.

A 'Relational' response must form a coherent whole in which individual statements are made in order to contribute to the overall argument. This is exemplified by learner 14:

"A computer can't reason things out given different information. It can only work things out if they're put in a specific way, and to put information into a computer you use an 'on' or and 'off' signal or a permutation of on/off signals that the computer can understand. To do this we use either paper tape or, in some cases a magnetic tape. Now the paper and card have small holes in them and when it passes over a light source, there's a piece of electrical equipment that can see that light through the holes. And the computer interprets it as an 'on' pulse. And when no light comes through the card it interprets it as an 'off' pulse. So in that way the computer is then receiving information that we're trying to put into it. And the magnetic tape works on a similar system as the tape recorder does - there are marks made on the tape, and the computer can understand it that way.

(Learner 14, p2a)

To qualify as an 'Extended abstract' response, a learner's account must in some way go beyond the original material presented. The learning task in this study did not lend itself very readily to the 'questioning of basic assumptions' or leaving open-ended conclusions. However some learners did show that their thinking had gone beyond the original learning material. For example, learner 2 substantially reordered the material in order to explain the fundamental principle of binary numbers as 'on/off' pulses more clearly than it had been explained in the learning text, as the extract from his response below illustrates:

"Well, computers work in a make or break dialogue... Because a computer can only understand 'on' and 'off' code, it works in a simple fashion. So it works in binary which is instead of being to a base of 10, it's to a base of 2. So that... if you want to transmit a signal... it works on this on/off principle...  
 ...Therefore if you want to make up the letter (number?) 5... that would be '1 - 0 - 1', and therefore that would be break, no break, break sort of thing. And this is something the computer can easily pick up because it's on/off, on/off - simple. And straightaway you can easily record this on punch cards or tape.

(Learner 2, p5)

The response of learner 20 also demonstrates characteristics of an extended abstract response by introducing a new analogy to explain a principle:

"The main points explain how a computer processes information. And whereas you and I communicate by means of speech, this form of information is not acceptable to a computer - it can't digest it or do anything with it. It doesn't mean anything to it, in the same way as if you're not a linguist and someone came at you with French and German, it wouldn't leave you any the wiser. The computer has to receive its information and process that information by observing electrical states ie. 'on ' and 'off' and combinations of that."

(Learner 20, p4)

Interview ScheduleTelecommunications Systems 1

Written questions :

⑤

1) In computing, a code is :

- a) Always numerical
- b) A simple way of presenting information to a computer ✓
- c) One hole punched in a computer tape

Choose your answer from a, b and c

b

2) Name 3 ways of recording the code for the computer :

- a) Magnetic Tape
- b) Punch Card
- c) Punch Tape

3

3) A bit is :

- a) A number
- b) The smallest unit of information a computer can process
- c) A small piece of computer tape

Choose your answer from a, b and c

b

4) The two state nature of electrical devices is essential for processing arithmetic operations because :

- a) computers are electrically powered
- b) it can be used to represent the two characters of the binary numbering system 0 and 1
- c) current or no current can be produced by using a switch

Choose your answer from a, b and c

b

68



## APPENDIX 11

### Analysis of learners' interpretations of the demands of the experimental learning task

The work of Fransson on the effects of intrinsic and extrinsic interest in learning (1977) highlights the need to find out how the learner himself perceives a learning task, rather than assume that the learner interprets it in the way the designer intended. For this reason the interview schedule included the following question:

"When I asked you to explain the booklet to me, how did you decide what to put in your explanation?"

(See appendix 3)

Interviewers did not always manage to ask this question, and when they did they sometimes framed it in slightly different words. However an analysis of responses does give an indication of how the task was interpreted by at least some of the learners.

All transcripts were read through and learners' responses to this question were noted. In accordance with the general design principles of this study, no *a priori* hypotheses were made about the content of these responses. The data was examined to identify any similarities between different learners' responses, and any patterns emerging.

The original question prompting an explanation of the learning task materials asked learners to explain 'the main points' (see interview schedule, appendix 3). Therefore it is not surprising that learners tended to respond to the question above by explaining how they identified which were the main points of the materials. Some went little further than simply restating the question;

"Well, the main topics ...the main points."

(No 13, p3)

(See also numbers 7 & 16)

Learner 21 included in his explanation;

"... the bits that I seemed to think were important and that I could remember, like the binary code."

(No 21, p3a)

Learner 2 also claimed that he had remembered 'the important points' and so included those (p8), as did learner 14 (p3a).

Occasionally it emerged that learners had been guided in their identification of the main points by the way the material was written. Learner 2 expresses this most clearly:

"The way its written encourages you to remember certain points."

(No 2, p8)

Learners 6, 19 and 22 also indicated this view.

One learner (3) seemed to be making an independent judgement about the main points, based on his understanding of the internal logic of the subject.

"Well I try to start with - I decide what I think it's about and I try to explain that. Start with the basic tools which are the punch cards and the tape and try to explain that. Then the natural progression is what they're used for. Then how they're used, and how the use of them affects the computer."

(No 3, p7)

Another learner claimed to select main points on the basis of his own level of interest in the subject:

"Well, I just picked the important points. To me the important points were....  
...That to me is as far as I want to go into computers at the moment."

(No 5, p6)

One group of learners were distinguished from the rest by the fact that they referred to the *context* of the learning task. They acknowledged that the task of explaining the learning materials was essentially an interaction between learner and interviewer. Each of these learners expressed a concern to provide an explanation which would be appropriate and understandable to another person. Within this framework there were variations of focus:

"I tried to explain it as I would want someone to explain it to me, taking into account that I've not done anything about computers before."  
(No 15, p3a)

"Its always difficult when you're talking to someone else because... it's okay if you say, 'I know absolutely nothing,' - I don't wish to be rude but - then you can say, 'right, that person's a complete idiot, and knows nothing, and I'll start at the very basic of what it does.' But obviously, you people are intelligent, so you've got to, sort of, say to yourself, 'Well they're not an idiot, so I don't want to say, 'one plus one equals two', you know?' But you've got to try and assess how basic is basic. So that is what I set to thinking."  
(No 8, p4a)

(See also numbers 12; 14 & 23)

Finally, there were a number of learners who revealed that they felt uncomfortable with the task of providing an explanation of the content of the learning materials. On the whole the TS1 course uses closed questions in tests and in self-assessment questions, and learners found this very open question unfamiliar.

"I don't like being put in the situation you've just put me in. You know, 'explain to me what it does'. I find that very difficult after just reading something, unless you're given an example. When you're given an answer paper (test paper) it just says, 'when such and such occurs does this happen or does that happen?' - which as far as I'm concerned is a much better way of doing it, because you probably do know the answer."

(No 18, p4)

(See also numbers 7 & 12)

APPENDIX 12

'OPEN TECH' INTERVIEW SURVEY

JUNE 1985

INTERVIEW SCHEDULE

Roffey Park Management College  
Eileen Sagar and Alison Strang

ORIENTATIONS

(1) HOW DID YOU HEAR ABOUT THE COURSE?

## PROBES

- Find out if Voluntary or Conscript
- Otherwise just trying to be friendly and relax them

(2) WHY DID YOU DECIDE TO DO THE COURSE?

Alternative Question: What are you hoping to get out of it?

## PROBES

- (a) As many different reasons as possible
  - If reason 1 didn't apply, would you still do it? Why?
  - Is there anything else you might get out of it?
- (b) Get an indication of which are the most dominant reasons
  - Which is the most important reason for you?

LEARNING OUTCOMES

I would like to ask you about the work that you have been doing most recently. That is the section on . .

PAUSE SLIGHTLY

(3) I'D LIKE TO ASK YOU TO EXPLAIN TO ME, AS YOU MIGHT TEACH A FRIEND . . .

Take a bit of time to think about it, and here's some spare paper in case you'd like to use it.

PAUSE

SO YOU'RE GOING TO EXPLAIN TO ME - AS YOU MIGHT TEACH A FRIEND . . .

<p><u>PROMPT:</u> No prompting here - except to give an indication that you are ready to hear more.</p>
---

- (4) COULD YOU SUMMARISE FOR ME WHAT YOU FELT THE PERSON WHO WROTE THIS WAS TRYING TO GET ACROSS - JUST IN A COUPLE OF SENTENCES?

PROBES:

- What is the essential message of the learning package - the nitty gritty?
- Why does the author think it's important for you to know that section?
- Is the student aware that the author has a message?
- What gave you that impression?

- (5) WHAT DO YOU FEEL YOU HAVE GOT OUT OF STUDYING ABOUT . . .

PROBES:

- Was it interesting to learn about . . .
- Does he relate studying to normal life?
- Does the content of the materials have personal significance for him?

Just now I asked you to explain to me about . . . . .

Different people seem to explain in different ways.

(6) HOW DID YOU SET ABOUT EXPLAINING IT TO ME?

PROBES:

- How does he describe the nature of the communication?  
(a real exchange of ideas, or a ritual in order to test him?)
- How did he interpret the demands of the situation
- Why did you pick out X to tell me about for example?
- What gave you the impression that it was important to do Y?



APPROACH TO LEARNING

Let's move on to talk about how you went about studying this particular section of the unit.

Have you brought the materials with you?

PAUSE - expect them to get it out

If not - Have you got them there?

V. IMP. I am interested in what you actually did  
but also in why you approached it in that way  
and what you were aiming at.

(7) WHAT WERE YOU AIMING AT WHEN YOU SAT DOWN TO STUDY  
THIS SECTION ON . . .

Alternative Question: What were you trying to achieve?

PROBES:

- Find out their conceptions of learning. What they think they should be doing when studying. And Why.
- What gave you that impression? (when they mention a perceived demand of learning)
- What does 'learning' mean for you? (when they mention the word 'learning')

- (8) Let's go back to when you first looked at the section on  
 . . . .

WHAT DID YOU DO WHEN YOU FIRST GOT TO IT?

- (a) Most people seem to read through first, but they approach reading in different ways.

IF WE TAKE THIS BIT OF THE MATERIALS (point to . . . .  
 COULD YOU SHOW ME WHAT YOU WERE THINKING AS YOU  
 READ IT THROUGH?

What were you trying to achieve as you read through?

- (b) GOING BACK TO WHEN YOU WERE STUDYING THE MATERIALS -  
 WHAT DID YOU DO NEXT?

(and repeat)

PROBES: Take S chronologically through experience of studying this section

- (a) Find out details of what he actually did (i.e. activities)
- (b) Find out reasons for each activity and what he's aiming to achieve through it
- What were you aiming at when you . . . ?
  - Why did you decide to . . . . ?
  - How did you feel that . . . . would help you?
  - Would you usually . . . . ? (If not, Why this time?  
 When would you do something else?)
  - Why did you do X (e.g. take notes) with this bit, and Y  
 (e.g. read and read) with that bit?
  - How could you improve that? (e.g. your note-taking)
  - Where did you get the impression that Z is important?
  - Were there any practical activities connected with the studying?

Other Essential Questions:

- (c) WHICH WAS THE MOST DIFFICULT PART? WHY?
- (d) WHY DO YOU THINK THAT SOME PEOPLE ARE BETTER AT LEARNING THAN OTHERS?
- (e) HOW DID YOU DECIDE THAT YOU WERE FINISHED WITH THIS SECTION AND READY TO MOVE ON?
- (f) WAS THIS TYPICAL OF THE WAY YOU NORMALLY APPROACH STUDYING?

(9) HOW MUCH TIME DID YOU SPEND ON THIS LEARNING PACKAGE / UNIT?

PROBES:

- Is this typical?
- If not, why was it different?
- How much time do you normally spend on studying a learning package/unit?

COURSE IN GENERAL

So far we've been talking fairly specifically about this last unit. To finish with, I'd like to broaden things a little and ask you about your feelings about the course as a whole.

(10) WHAT DO YOU FEEL ABOUT STUDYING GENERALLY?

Alternative Question: - What did you feel when you sat down to study this section?  
- Did you enjoy it?

PROBES: Clues to underlying emotional responses which might influence approach to learning.

- Why does it (studying) affect you that way do you think?

(11) I WANT YOU TO IMAGINE THAT A FRIEND OF YOURS WAS ABOUT TO START THIS COURSE AND HE . . . . (quote back S's own 2 main reasons for doing the course, as motives for 'his friend', e.g. 'Wanted to get Qualification etc.. . .')

HOW WOULD YOU ADVISE HIM TO APPROACH THE COURSE?  
WHAT SHOULD HIS AIMS AND PRIORITIES BE?

PROBES: What general attitudes and approaches does he think are appropriate to the course.

If particular methods and strategies are given, ask -

- Why are they appropriate?

- What does he think a student should be aiming to achieve as he goes through the course (e.g. minimum effort necessary to cope/ a full understanding/ high TMA grades?)

(12) HOW DO YOU YOURSELF MATCH UP TO ALL THAT?

PROBES:

How does he see himself as a learner?

Reasons why he doesn't match up to the ideal (e.g. deliberate choice of priorities, or failure?)

-

- Does it matter? (when he doesn't match up)

Where he talks about the perceived demands of the course -

- How do you get the impression that X is important?

COURSE ASSESSMENTS

I believe that you have had a . . . . . test a while ago

(13) HOW DID YOU GET ON IN THAT

## PROBES:

- (a) General reactions/feelings about the experience of the test
- (b) Indication of marks/grade

(14) HOW DID YOU PREPARE FOR IT?

PROBES: Reasons and Aims for each technique

- What are you aiming at when you . . . ?
  - Why did you decide to . . . ?
  - How did you feel that . . . would help you?
  - Would you usually . . . ?
- If not - Why this time?
- When would you do something else?

(15) HAS THE EXPERIENCE OF THE TEST AFFECTED THE WAY YOU  
NOW GO ABOUT STUDYING?

Alternative Question: Do you think that knowing what the tests will  
be like has helped you in your learning?  
How?

PROBES: 2nd Question only to be asked if 1st question has definitely  
drawn a blank. It is deliberately more biased.

Specific examples of changes in attitude/approaches to study as a  
result of

- experience of past tests
- expectations of future tests

Finally, everyone seems to find some aspects of studying more difficult  
than others -

(16) WHAT WOULD YOU SAY HAS BEEN THE MOST DIFFICULT ASPECT  
OF STUDYING FOR YOU?

PROBES: Accept what comes.

If already discussed, ask:

- What other aspects were more difficult than average?

Does it reveal any hidden barriers to learning we haven't considered?



Thank you, that more or less completes my specific questions.  
But I'd also like to take the opportunity to ask you:

(17) DO YOU HAVE ANY OTHER COMMENTS TO MAKE ON ANY ASPECT  
OF THE COURSE AT ALL?

I would be happy to pass them on to . . . . . either praise or criticism.

Thank you for raising that.  
It has been really valuable to talk to you.

---

OTHER DETAILS

Learning Package/Unit discussed:

Results of BEFORE test:

Results of AFTER test:

Age: below 25  
25 - 40  
40+

Sex:











## APPENDIX 14

Appendix 14: Table of all category data for study 1

Learner number	Qual/Learn.			Quant. -ity	Defn. of 'learn'	Focus of attention	Conception of Learning									Rit. v		No. of sophis.	Orientations							
	A	B	C				1	2	3	4	5	6	7	8	9	TOT	Pers.		VI	VE	AI	PI	PE	TOT		
2	A	9	EA	4	U	Vii Mii	*	*	*	*							4	√	x	1	*	*2		*	*1	4
19	A	9	R	5	M	Miii	*								*		2	x	x	0		*1				1
20	A	8	EA	4	M	Mi	*	*		*							3	√	x	1	*2	*1				2
12	A	7.5	R	5	U	Vii	*			*							2	x	x	1	*2	*1				2
17	A	7.5	R	4	M	Mii	*		*	*		*	*	*			6	x	√	2	*	*2		*1	*	4
10	A	7	MS	5	U	Vii	*		*	*	*						4	x	√	2	*2	*1	*	*		4
8	B	9	EA	5	U	Vi Mii	*	*		*	*		*	*			6	√	√	2	*2			*1		2
15	B	7	R	5	M	Mii	*	*									2	√	x	0	*2	*1				2
22	B	4.5	MS	5	U	Viii Mii	*	*		*			*		*		4	√	√	1	*2	*1				2
1	C	6	R	5	M	Mii	*		*	*							3	x	√	1	*2	*1				2
14	C	6	R	miss.	M/K	Viii Mii	*	*		*			*	*			5	√	x	1	*	*1		*2		3
3	C	6	MS	4	K	Vii	*		*	*		*	*				4	x	√	2	*2	*2	*1			3
18	C	3.5	MS	5	U	Vi	*	*		*							3	√	√	1	*2	*1				2
13	C	3	MS	5	M	Mii	*	*									2	√	x	0	*1	*2				2
23	C	3	MS	5	M	Mii	*	*		*							3	√	x	1	*2	*1				2
11	C	2.5	MS	5	K	Vii Mi	*			*							2	x	√	1	*1	*2				2
6	D	5	MS	4	M	Viii Mii	*	*		*							3	√	x	1		*		*1	*2	3
7	D	3.5	R	miss.	M	Mii	*	*									2	√	x	0	*2	*1				2
21	D	3	MS	3	U	Viii Mii	*			*	*						3	x	√	2	*1	*2				2
9	E	6.5	MS	4	K	Mi	*								*		2	x	x	0		*	*	*1	*2	4
16	E	3	MS	5	M	Mii	*	*		*				*			4	√	x	1	*2	*1				2
5	F	1.5	MS	5	M	Mii	*	*		*		*	*	*			6	√	√	1		*2		*1	*	3
4	F	1.5	US	4	U	Viii Mii	*										1	x	x	0		*2		*1		2