

HVAC Systems Energy Demand vs. Building Energy Demand

Ivan Korolija^{1,*}, Vic I Hanby¹, Yi Zhang¹ and Ljiljana Marjanovic-Halburd²

¹Institute of Energy and Sustainable Development, De Montfort University, UK

²Department of Built Environment, Anglia Ruskin University, Chelmsford, UK

*Corresponding email: ikorolija@dmu.ac.uk

ABSTRACT

Building energy demand is the amount of heating and cooling energy required to deliver the desired indoor conditions. It is dependent on various building parameters such as building fabrics, glazing percentage, occupancy pattern, level of internal gains, etc. Despite that building demand is often used for energy performance evaluation in the practice, it can be inaccurate and even misleading when the building is serviced by an HVAC system. The amount of energy required by the HVAC system from the primary sources or systems, to deliver the required heating and cooling in the building, does not equate building demand in most circumstances. An HVAC system may show different energy performance in different buildings, due to that the HVAC system's characteristics and operational conditions are affected by the thermal load and behaviour of the building. It is therefore necessary to analyse the correlation between building's dynamic load profile and the performance of the HVAC systems.

In this paper, we used a typical rectangular UK office building with combined open plan and cellular offices to analyse the correlation between the building's heating and cooling load profile and the performance of different HVAC systems, i.e. the variable air volume system (VAV), the constant air volume system (CAV), the fan coil with dedicated outside air system (FC) and the chilled ceiling with radiator heating and dedicated outside air system (ChCeil). Building fabrics are selected to comply with the latest UK national standards. By running a series of simulations in EnergyPlus and in-depth analysis of outputs, we aim to provide a set of guidelines on HVAC system selection at early design stages based on total energy performance.

Keywords: Office Buildings Energy Demand, VAV, Fan-Coils, Chilled Ceiling,

INTRODUCTION

Buildings in general are responsible for around 40% CO₂ emission. A significant amount of energy in buildings is consumed by HVAC system. HVAC system is usually divided into two parts; primary HVAC system and secondary HVAC system. Primary HVAC system is composed of equipment which generates heating/cooling energy such as boilers and chillers. This energy is distributed through a building by a secondary HVAC system in order to respond to a building cooling/heating demand. The most common secondary HVAC systems in the UK are variable air volume system (VAV), fan-coil system with dedicated air (FC) and constant air volume system (CAV).

A lot of studies have been reported on the influence of passive building elements on the building energy demand. Passive building elements which are analysed are mainly amount of glazing and glazing properties, shading devices, daylighting analysis, building orientation, building fabrics, etc. A building cooling/heating demand calculated in this way has been in most cases automatically assumed to be the amount of energy which has to be generated by source (primary HVAC system) and delivered to the building without taking into consideration the possible impact of a secondary HVAC system on energy demand. On the other hand, studies about secondary HVAC systems are mainly focused on analysing different HVAC system parameters based on the one particular case building.

The energy performance of a secondary HVAC system depends not only on the building heating and cooling demand characteristics, but also on the system configuration and operational parameters. The authors have shown in their recent paper (Korolija et al., 2009) that system parameters, such as supply air temperature or air side economizer box usage, can have significant impact on the system consumption. After analysing the HVAC system configurations, Zhang et al. (2006) came to conclusion that in theory, an “optimal” system in terms of energy performance can exist if the following three criteria are met: (1) opportunities of inter-zonal heat exchange is provided; (2) infinite amount of free cooling is accessible; (3) simultaneous heating and cooling in the system is eliminated. This concept is awaiting confirmation in practice, especially when the interaction between the building structure and the HVAC system is considered.

In this paper we will analyse the influence of different secondary HVAC systems on building total energy consumption. We aim to show that the HVAC system is a main key in determining building consumption and it cannot be separated from the building energy analysis.

METHODOLOGIES

Models of the building and the HVAC systems are created in the EnergyPlus v.4.0 simulation software and simulated by using a London-Gatwick weather file.

Building model

The building model created for the purpose of this study is a square office building with a 22.5 by 22.5 meters footprint and 3.5 meters floor-to-ceiling height. Building has three floors and each floor is divided into four zones (Figure 1). Main zone, the zone 1, has an open plan

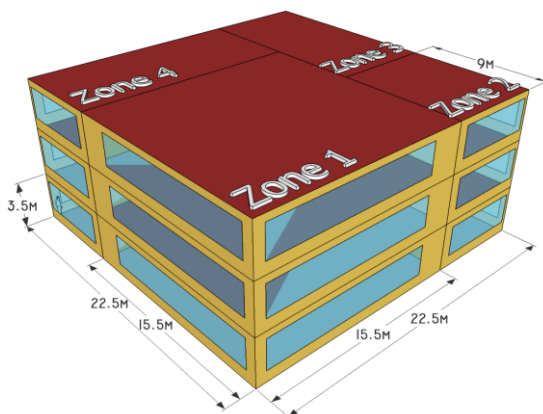

Figure 1. Office building model

Table 1. Building fabrics U-values

BUILDING ELEMENTS	U-VALUE [W/m ² K]
External Wall	0.35
Flat Roof	0.25
Ground Floor	0.25
Glazing	2.10

office arrangements, while zones 3 and 4 represents cellular office layout. Zone 2 represents common areas such as corridors, toilets, reception areas, etc. The quantity of glazing is the same for each façade and amounts to 50% of external wall area, which is a typical value for medium glazed office buildings. The building fabrics are set to comply with the latest UK national standard (Building Reg. App. Doc. L2, 2006) with the building elements U-values presented in Table 1.

Office buildings belong to the building types with clearly defined occupancy pattern. Building is occupied during weekdays between 7am and 7pm only and the indoor thermal condition and air quality has to be strictly controlled in that period. Zone air temperatures are controlled by dual setpoint thermostats which keep offices at 22°C during heating period and at 24°C during cooling period, while common areas are maintained at 20°C and 26°C respectively. During unoccupied hours, thermostat calls for heating if temperature drops below 12°C in any of zones, while overheating is prevented by turning the cooling on if temperature exceeds 28°C in offices or 30°C in common areas. These values are recommended by CIBSE (2006) and they are compatible with indoor air temperatures cited in the ASHRAE Handbook (2007).

Internal heat gains in office buildings can have a significant effect on their thermal behaviour and energy consumption. According to Jenkins (2009), internal heat gains in UK office buildings are dominant reason why cooling systems in offices exist. The levels of different internal gains in office zones depend on whether it's open plan or cellular arrangement. The occupant density of 9 m²/person with a total heat gain of 108 W/person (CIBSE, 2006) is a typical for open offices with an equipment heat gain of 15 W/m² (CIBSE, 2005). On the other hand, cellular offices are usually shared by two or three people or sometimes are designed for single occupancy, which lower occupant density to 14 m²/person and decrease equipment heat gain to 10 W/m². Artificial lighting heat gains are selected to comply with the benchmark value of 12 W/m² (ECG019, 2003). To decrease the level of internal gains, we decided to implement daylight control in office zones. Artificial lighting is reduced whenever it is possible to benefit from daylighting while still achieving the desired illuminance target value which is set to 500 lux for the office type activity. In addition to internal gains, fresh air requirements and infiltration rates also have to be defined. According to the Building Reg. App. Doc. F (2006), a minimum of 10 l/s per person is needed to satisfy fresh air requirements while infiltration rate is set to 0.3 air changes per hour.

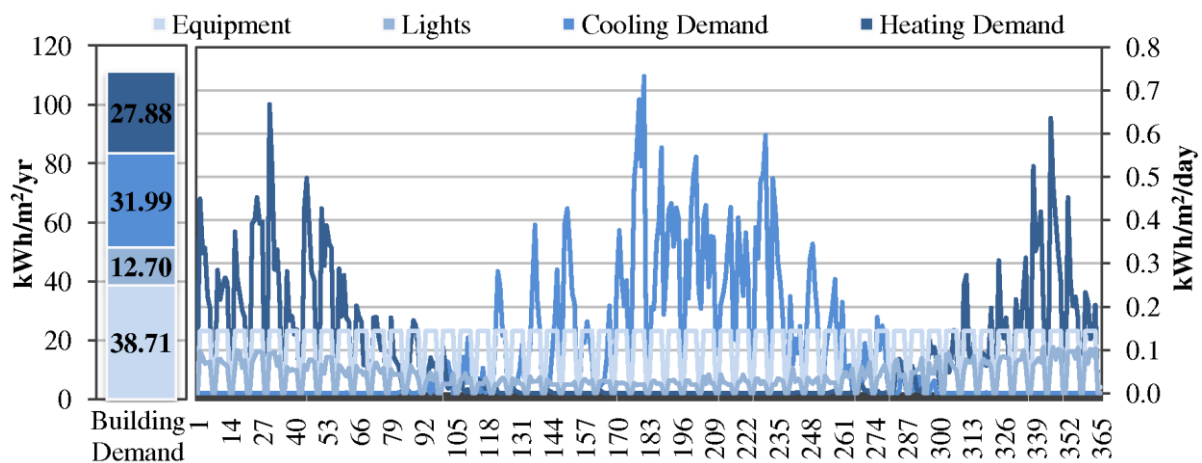

Figure 2. Building energy demands

Having defined previous parameters, annual simulation can be run to determine building demand. Graph on the left side in Figure 2 shows building annual demand per square meter classified into four categories: equipment electricity, lights electricity, cooling and heating. Equipment electricity demand has constant profile which can be seen on the right diagram. Opposite of that, light electricity demand varies by the time of the year. The reason is in included daylighting simulation which decreases light power whenever is possible to benefit from natural source. If daylighting simulation had not been included, lights electricity demand would have similar profile as equipment electricity demand. Also, it would affect cooling and heating demand in a way that, due to higher internal gains, cooling demand would be increased while heating demand would be decreased.

Cooling/heating demands are calculated by taking into consideration standard heat gains and heat losses which are:

- Transmission heat gains/losses through building envelope elements,
- Solar heat gains through glazed areas,
- Internal heat gains/losses from artificial lighting and office equipments,
- Infiltration air heat gains/losses, and
- Fresh air ventilation heat gains/losses.

Advanced methods of decreasing building demands, such as using outdoor air for free cooling or night-time ventilation to cool down building mass, are not included in building demand calculations. This is because of inability of employing such measures without using secondary HVAC system equipped with advanced controls.

HVAC System models

However, the main question in this paper is how different HVAC systems respond to the building demand. For that purpose, four HVAC systems have been coupled with this building and simulated. First system is Variable Air Volume System (VAV) and the second system is Constant Air Volume System (CAV). Both systems belong to the all-air HVAC system group and are equipped with zone reheating boxes. Last two systems are air-water systems, in particular Fan-Coil with dedicated outside air system (FC) and Chilled Ceiling System (ChCeil) which also has air handler which delivers only fresh air and in addition is equipped with radiators to respond on heating demand.

VAV System (Figure 3) varies its supply air volume rate, while keeping a supply air temperature constant, to match the reduction of space load during part-load, to maintain a

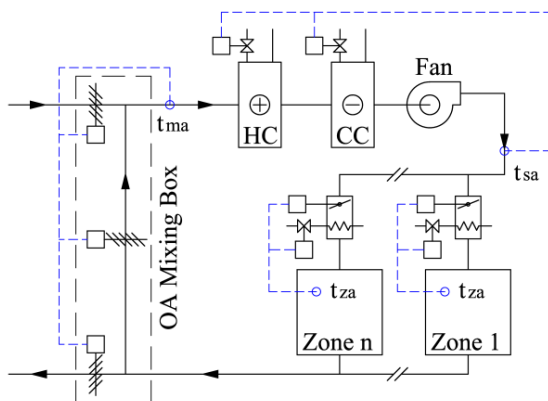

Figure 3. Variable air volume system

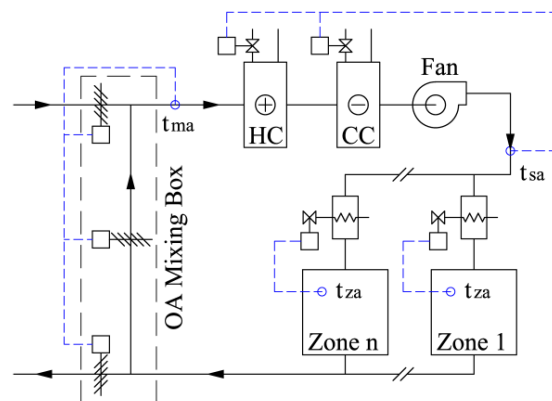

Figure 4. Constant air volume system

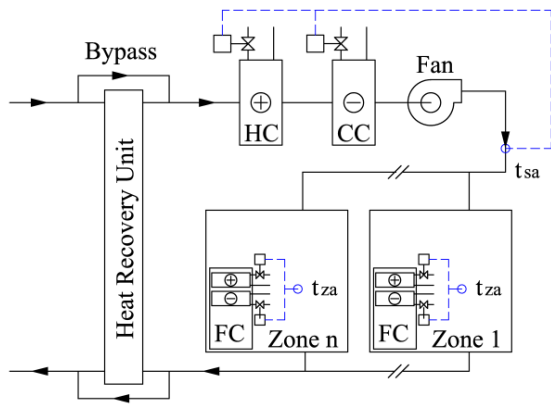

Figure 5. Fan-coil system

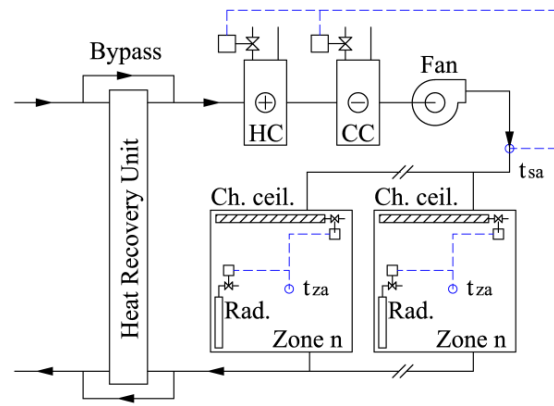

Figure 6. Chilled ceiling system

predetermined space parameter, usually air temperature, and to conserve fan power at reduced volume flow. Main heating and cooling coils are controlled by supply air temperature (t_{sa}) which is set to 16°C . Preconditioned air is delivered to the zones through the air reheating boxes where, if there is a need, is additionally heated. Each air reheating box is composed of a damper and hot water coil, both operated by zone temperature sensor (t_{za}), with a reverse damper action. This means that in the heating mode unit starts at minimum air flow and minimum hot water flow. With a load increment, the hot water flow is increased until it reaches maximum flow, then the air damper starts to open to meet the load. In contrast to the VAV system, CAV system (Figure 4) keeps the air volume flow rate constant while varies its supply air temperature (t_{sa}) according to the cooling demand of the warmest zone. This strategy minimizes zone reheat coil energy or overcooling.

Amount of the outdoor air in both systems is controlled via outdoor air mixing box equipped with economizer which mixes return air and outdoor air in certain proportions to meet the mixed air temperature setpoint (t_{ma}). The mixed air temperature is lower than supply air temperature by around one centigrade because the supply air stream, by passing over the fan motor, absorbs fan dissipative heat. By using the economizer unit, the amount of outdoor air is increased whenever is possible to benefit from free cooling.

FC system, shown in Figure 5, is composed of zones four-pipe fan coils and air handing unit which distributes 100% fresh air enough only to meet fresh air requirements. Fresh air supply temperature is controlled by variable temperature sensor, which varies supply air temperature between 16°C and 22°C in order to maximise benefits from free cooling. However, free cooling is very limited due to significantly lower supply air volume in comparison with the VAV and CAV systems. Fan coil is composed of fan, which recirculates room air, and heating and cooling coils. Indoor temperature is controlled by local thermostat which varies water flow rate through heating or cooling coil to respond to the zone demand. In the case when there is no need for heating or cooling, fan coil fan is switched off. Outdoor air is pre-treated by installing a heat recovery unit (HRU) which exchanges heat between supply air stream and exhaust air. Heat recovery unit is equipped with bypass dampers to maximise free cooling by bypassing the heat exchanger.

Chilled ceiling system (Figure 6), in comparison with previously described systems, delivers cooling energy in slightly different way. Chilled water pipes are embedded into concrete ceiling, which results in decreasing the ceiling surface temperature so cooling is achieved partially by convection heat transfer between surface and room air and partially by radiation.

According to Mumma (2002) and Novoselac and Srebric (2002), as a result of these two occurrences, the room dry-bulb air temperature with the chilled ceiling system can be approximately 2°C higher to obtain the same thermal comfort as with the all air system. Due to that, the cooling temperature setpoint is increased from 24 to 26°C in offices and from 26 to 28°C in common areas. Distribution of the fresh air is the same as in the FC system which means that one air handler equipped with heat recovery unit is used. Building heating demand is covered by hot water radiators.

RESULTS AND DISCUSSIONS

The office building has been coupled with different HVAC secondary systems and simultaneously simulated by using EnergyPlus. The simulation outputs are divided into four main categories:

- Equipment and lights electricity demand,
- Heating energy demand,
- Cooling energy demand, and
- Auxiliary equipment electricity demand.

Equipment and lights electricity demand is not HVAC system dependent and it has been previously described. The real influence of the secondary HVAC system performance on the building energy consumption can be seen if we compare the HVAC system cooling/heating demand with a building demand. Moreover, the HVAC system auxiliary equipment electricity consumption, which powers fans and pumps, has to be added at the top of that.

In Figure 7 we can see a huge diversity in HVAC system demands when compared with a building demand, which is presented in the first column. Each system requires less energy to maintain the building at required temperature level. The lower demand is influenced by two parameters: decreased ventilation losses and additional heat gains from the auxiliary equipments, in particular fans and pumps.

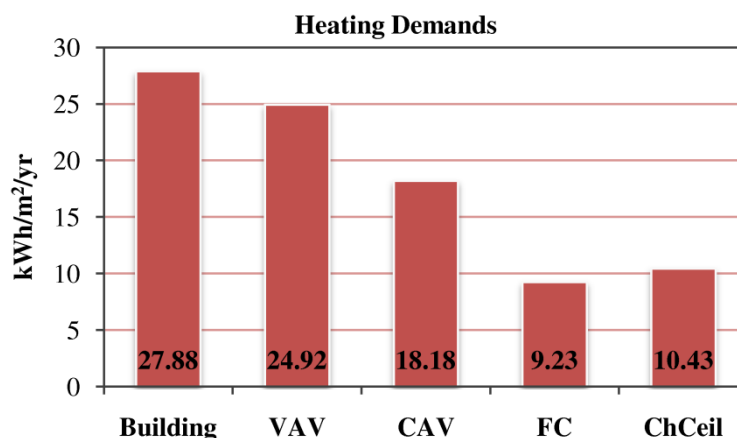

Figure 7. Systems heating demand

The all-air systems (VAV and CAV) reduce ventilation losses by mixing a warm return air stream with a cold outdoor air stream to maintain desired supply air stream temperature setpoint. In the VAV system, this setpoint is fixed at 16°C, while in the CAV system it varies between 16 and 22°C, which further reduces ventilation losses. It is important to mention that the minimum fresh air is guaranteed in the both systems all the time by maintaining the outdoor air volume flow rate greater than or equal to the minimum fresh air requirements. On

the other hand, the air-water systems (FC and ChCeil) reduce ventilation losses by using a heat recovery unit with overall effectiveness of 75%. These systems operate with a fresh air only and deliver a minimum amount of outdoor air to the building to fulfil fresh air requirements. Outdoor air is preheated by a warm return air stream in the heat recovery unit.

The impact of dissipative heat from pumps and fans become apparent after inspecting FC and ChCeil systems heating demand. Both systems have the same air side (same air handler size, fan size and operating time) and the localised zone heating source (fan-coils and radiators). However, the fan-coil system performs better because of the dissipative heat gains form fans inside fan-coil units.

HVAC system cooling demands, presented in Figure 8, can be classified into two categories: systems which require more cooling energy when compared with building demand and systems which require less cooling energy.

In the first category are all-air systems (VAV and CAV). The main reason why the all-air systems perform so well is the usage of free cooling whenever it is possible. The CAV system outperforms the VAV system, because it always works with maximum air volume flow rate, which increases free cooling availability. The influence of dissipative heat gains, which also exists here, is diminished by free cooling.

On the other hand, the air-water systems (FC and ChCeil) suffer from limited free cooling because they operate with minimum air volume flow rate. The effect of free cooling is even more decreased by supply air temperature setpoint 16°C. This means that when the outdoor air temperature is below 16°C and there is a need for cooling, the air has to be preheated before delivered to the space. In the building cooling demand calculations, under the same circumstances, there is no setpoint limitation which results in additional benefits from free cooling. Opposite of the all-air systems, the influence of dissipative heat gains cannot be neglected in the air-water systems. All of this results in higher cooling demands. It is also important to mention why the ChCeil system has slightly lower cooling demand in comparison with the FC system. Namely, two degrees centigrade higher cooling setpoint in the case of the ChCeil system results in a reduction in the building fabric and ventilation air cooling loads. It also means that the ventilation air can remove more sensible heat since there is about a 2°C larger temperature rise as the air passes through the space.

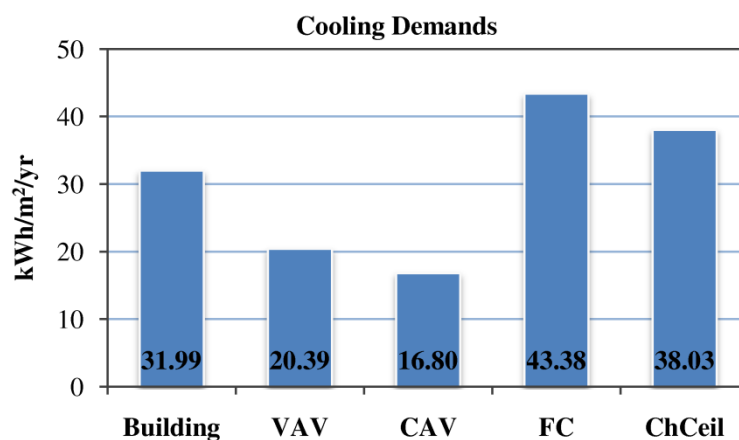

Figure 8. Systems cooling demand

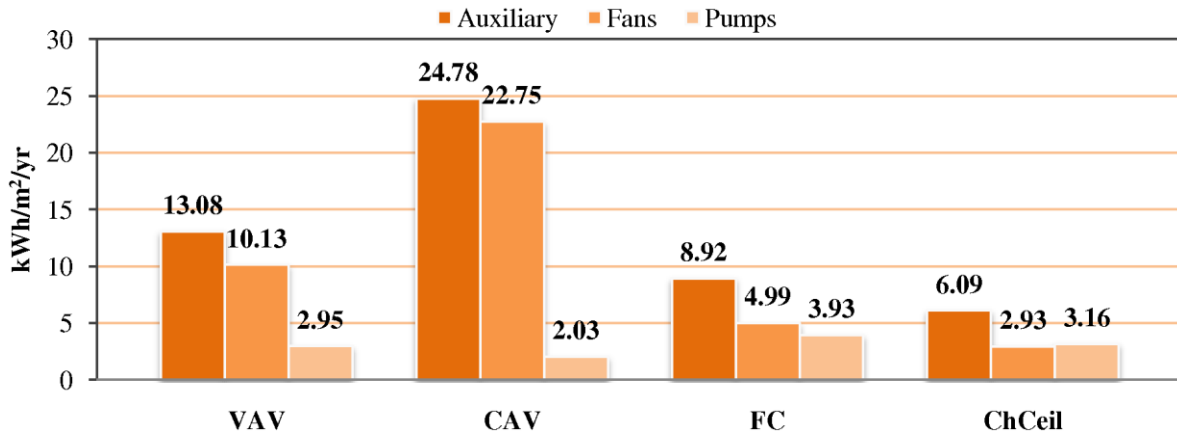

Figure 9. Systems auxiliary energy demand

In the last graph (Figure 9) the auxiliary energy consumption (fans and pumps energy consumption) is presented. The auxiliary energy consumption is often overlooked when discussing building energy consumption but, as it can be seen from the figure, it should not be neglected. Fans and pumps are powered by electricity and as expected, the all-air systems have much higher consumption when compared with air-water systems. This is mainly due to higher fan consumption. The worst system, in terms of auxiliary energy consumption, is the CAV system. The CAV system operates all the time with constant maximum air flow rate which results in enormous fan consumption. By introducing variable flow rate in the VAV system, fan consumption is lowered more than twice. Due to lower cooling demands, all-air systems also have lower pumps consumption. On the other hand, when FC system was compared with ChCeil system, we can conclude that ChCeil system requires slightly less energy for auxiliary equipment, mainly due to usage of zone passive heating and cooling equipment (radiators and embedded pipes).

The next step would be to investigate environmental impact of each of these systems. The best way of doing this is by comparing their CO₂ emissions. CO₂ emission can be calculated by using the appropriate green house conversion factors, which depend on primary energy source and give one completely new dimension to the building evaluation. Secondary HVAC system heating and cooling demand can be covered by different primary energy sources such as gas fired boilers, district heating/cooling, air/water cooled chillers, ground sources, renewables, etc. More in depth analysis should include simultaneous simulation of building, secondary system and primary system, but this is beyond the scope of this paper which addresses secondary HVAC system only.

CONCLUSION

The results presented in this paper clearly indicate that in buildings serviced by heating, ventilating and air-conditioning (HVAC) systems, it is inappropriate to evaluate building energy performance based only on its heating and cooling loads. For the four investigated HVAC systems, i.e. the variable air volume system, the constant air volume system, the fan-coil system and the chilled ceiling system, the difference between system demand and building demand varied from over -45% to +35% for cooling and between -10% and -70% for heating. Up to 70% decrement in heating demand for the fan-coil system and the chilled ceiling system attributed to the heat recovery unit, whose effect would not have been accounted for in load calculations of the buildings.

Secondly, the auxiliary energy consumption of the HVAC systems should not be overlooked. Significant amount of electricity is consumed by auxiliary equipment (pumps and fans) in all-air systems such as CAV and VAV, due to the large volume of air they process. The VAV system in our study required 13kWh/m² electricity per annum. The CAV system, however, consumed almost 25 kWh/m² electricity per annum, which is higher than both heating and cooling demand, respectively. Air-water systems (the fan coil and the chilled ceiling system) showed lower auxiliary electricity consumption of 6 and 9 kWh/m² per annum, respectively.

ACKNOWLEDGEMENT

The authors would like to acknowledge financial support of this work which forms part of the CITYNET project funded via the Marie Curie Research Training Network.

REFERENCES

- ASHRAE. 2007. Handbook-HVAC Applications (SI), American Society of Heating, Refrigerating and Air-Conditioning Engineers, Inc., Atlanta, GA.
- CIBSE. 2005. Guide B: Heating, Ventilating, Air Conditioning and Refrigeration, Chartered Institution of Building Services Engineers, London, UK.
- CIBSE. 2006. Guide A: Environmental design, Chartered Institution of Building Services Engineers, London, UK.
- ECG019. 2003. Energy Efficiency-Best Practice Programme – Energy Consumption Guide 019: Energy Use in Offices, Carbon Trust.
- Jenkins, D.P. 2009. The Importance of Office Internal Heat Gains in Reducing Cooling Loads in a Changing Climate, *International Journal of Low-Carbon Technologies*, 4(3), 134-140.
- Korolija, I., Zhang, Y., Marjanovic-Halburd, L., and Hanby, V.I. 2009. Selecting HVAC Systems for Typical UK Office Buildings, 6th Int. Symposium on Heating, Ventilating and Air Conditioning - ISHVAC 2009, Nanjing, China, 388-396.
- Mumma, S.A. 2002. Chilled Ceilings in Parallel with Dedicated Outdoor Air Systems: Addressing the Concerns of Condensation, Capacity, and Cost, *ASHRAE Transactions*, 108(2), 220-231.
- Novoselac, A., and Srebric, J. 2002. A critical review on the performance and design of combined cooled ceiling and displacement ventilation systems, *Energy and Buildings*, 34, 497-509.
- The Building Regulations. 2006. Approved document L2: Conservation of fuel and power, Office of the Deputy Prime Minister, UK.
- The Building Regulations. 2006. Approved document F: Ventilation, Office of the Deputy Prime Minister, UK.
- Zhang, Y., Wright, J. A., and Hanby, V. I. 2006. Energy aspects of HVAC system configurations – problem definition and test cases, *HVAC&R Research Special Issue*, 12(3c), 871-888.