

Selecting HVAC Systems for Typical UK Office Buildings

Ivan Korolija^{1,*}, Yi Zhang¹, Ljiljana Marjanovic-Halburd², Vic I Hanby¹

¹Institute of Energy and Sustainable Development, De Montfort University, United Kingdom

²Department of Built Environment, Anglia Ruskin University, Chelmsford, United Kingdom

*Corresponding email: ikorolija@dmu.ac.uk

ABSTRACT The energy performance of different HVAC systems varies, and, more importantly, is dependent to the characteristics of the building. To select a suitable HVAC system for a particular building at early design stages presents a significant challenge to engineers. In this paper, we use a typical open-plan UK office building to analyse the correlation between its dynamic load profile and the performance of various HVAC systems. EnergyPlus models of the building and the systems are created. A number of parameters (e.g. insulation level, HVAC system types, supply air temperature setpoint and fresh air supply) that affect the heating/cooling energy consumption are varied. By running a series of experiments and analysing the results, we aim to provide guidelines to assist the selection of HVAC systems for UK office buildings.

Keywords: HVAC System, Office building, Energy performance, VAV, CAV

INTRODUCTION

The energy performance of a HVAC system is determined by its design and suitability to meet the heating and cooling load of the building. Some popular HVAC system types, e.g. the centralized variable air volume (VAV) or constant air volume (CAV) systems, are in fact highly inefficient in many cases. Zhang et al. (2006) summarized three key criteria for energy efficient HVAC system design, i.e. (1) the ability to minimize outside air load; (2) the ability to eliminate simultaneous cooling and heating, as well as to take the full advantage of free cooling; (3) the availability of inter-zonal airflow or heat exchange. It was concluded that in terms of system configuration, a system based on fan-coil units, dedicated fresh air handlers, and inter-zonal air flow paths would be the best solution in most situations. However, the implementation of such a system is yet to be seen.

Despite their inherent disadvantages, centralized all-air systems (especially the VAV system) are still favoured according to industrial design guides. The energy efficiency of these systems is largely dependent on the thermal characteristics of the building, i.e. (the imbalance of) the zonal heating and cooling loads and fresh air demands. Other design parameters such as equipment sizing can be a deterministic factor for poor energy performance, too, if not selected carefully. As a result, the only way to achieve a good HVAC system design is to analyse the performance of the system and the building simultaneously by using dynamic simulation tools. This paper aims to provide an example and initial investigation of how to choose a suitable HVAC system for an office building in the UK climate.

The usage and thermal properties of a building plus boundary conditions (e.g. climate) determine the profile of heating and cooling load. Obviously, many design features, including archetype, orientation, glazing, wall and window construction, shading and zoning to name

but a few, have a significant impact on the thermal characteristics of the building. Design decisions should be taken on the basis of the particular climatic and usage circumstances. Rules of thumb such as “better insulation will save energy” are not universally applicable. For example, Masoso and Grobler (2008) showed in their simulation a “point of thermal inflexion” does exist: when the cooling set point is over a certain value, depending on the average temperature during the cooling season, more insulation will cause cooling load to rise rather than decrease. This effect is also observed in our own investigation.

Al-Homoud (1997) optimized the design parameters (U-values of wall, roof and glass, surface absorptance, thermal mass, shading coefficient, glazing area, air tightness, and orientation) of a typical office building with a VAV system in different climatic zones. The results showed, in a hot and humid climate, the optimal U-value tend to be higher than that in cool to moderate climates, whereas higher wall surface absorption is preferred in a cool climate. Al-Homoud also observed that “building orientation with the long side facing south is generally the optimum solution in all climates”. However, further explanation was not offered in the report. From our experience with the VAV system, we suspect that the answer may be defined by the interaction between the zonal load profile and the centralized air system. This, of course, deserves further investigation.

A similar investigation was carried out on an office building for different Turkish climate zones (Eskin and Turkmen, 2008). Apart from the building design parameters, ventilation rates and outdoor air control strategies of the HVAC system (VAV) are also compared. It is evident that the potential energy savings can be achieved by choosing the parameters or applying different technologies which are influenced by the climate. However, further analysis would be needed to generalize the results. Becker and Paciuk (2002) investigated the effectiveness of various night ventilation and night cooling strategies in office buildings that have different levels of thermal mass, insulation and internal load. Different optimum strategies have been identified for different building types. Especially in the cases with high internal load, the benefit of better insulation diminished to negligible level.

In regard to HVAC systems, the VAV system is probably the most extensively studied system type. One of the advantages of the VAV systems is the potential savings on fan energy consumption. However, reduced fresh air supply (and therefore poor indoor air quality) can occur in the zones with partial cooling load. The CAV systems, on the other hand, are often associated with high fan cost. Recent developments include adaptive cold deck temperature resetting for the VAV systems (Yuan and Perez, 2006), and variable speed fan for the CAV systems (Cho and Liu, 2009), which effectively converging toward a variable volume and temperature (VVT) strategy. The key question to answer in the present study is, given the thermal characteristics of the building, how well each type of HVAC system will perform.

METHODOLOGIES

Building Model

The building model created for the purpose of this study is a three story high narrow plan office building with a 32 by 16 meters footprint and floor-to-ceiling height of 3.5 meters (Figure 1). Each floor is divided into two zones. First zone is a large open office area while second zone represents common spaces such as corridors, toilets, tea kitchen, etc. The quantity of glazing is the same for each facade and amounts to 50% of external wall area, a typical value for medium glazed office buildings. Two sets of building fabrics are used to

compare the building thermal properties and their effects on energy consumption. A building's thermal properties are often determined by its age. The first set of building fabrics (BF1) complies with the Building Reg. App. Doc. L (1990) which represents low level insulated building, while building fabrics two (BF2) represents the current best practice constructions with U-values significantly lower compared to the required U-values stated in the current UK national standard (Building Reg. App. Doc. L2, 2006). A parallel review of both building fabrics U-values is presented in Table 2.

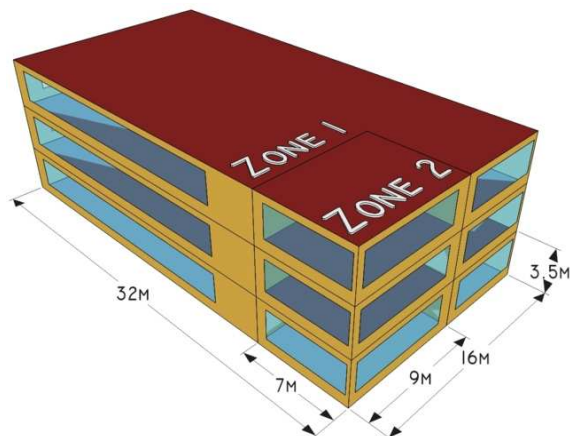

Figure 1. Office building model.

Table 2. Building Fabrics U-Values [$\text{W}/\text{m}^2\text{K}$].

	Building Fabrics 1 [$\text{W}/\text{m}^2\text{K}$]	Building Fabrics 2 [$\text{W}/\text{m}^2\text{K}$]
Cavity Wall	0.53	0.25
Flat Roof	0.45	0.15
Ground Floor	0.84	0.15
Glazing	3.21	1.98

Indoor thermal condition is controlled by dual setpoint thermostat. During occupied hours (weekdays between 7am and 7pm), offices are heated to 22°C or cooled to 24°C , while common areas are maintained at 20°C during the heating period, and 26°C during the cooling period. For the unoccupied period, the thermostat does not allow indoor air temperature to drop below 12°C in the whole building, or exceed 28°C in offices and 30°C in common spaces. These values are recommended by CIBSE (2006) and they are compatible with indoor air temperatures cited in the ASHRAE Handbook (2007).

Internal heat gains in office buildings can have a significant effect on their thermal behaviour and energy consumption. Internal gains are generated mainly from occupants, office equipment and artificial lighting. The occupant density is set to $9 \text{ m}^2/\text{person}$ with a total heat gain of $108 \text{ W}/\text{person}$ (CIBSE, 2006), while the equipment heat gain is limited to $15 \text{ W}/\text{m}^2$ (CIBSE, 2005). Benchmark value of $12 \text{ W}/\text{m}^2$ for artificial lighting heat gain is used in this study (ECG019, 2003). In addition to internal gains, fresh air requirements and infiltration rates have to be defined to complete all necessary data for building loads simulation. A minimum of 10 l/s per person is needed to satisfy fresh air requirements (Building Reg. App. Doc. F, 2006) while 0.3 air changes per hour is taken as the infiltration rate.

Having defined previous parameters, annual simulation can be run to determine building loads. Simulation has been done in the EnergyPlus v3.1 using a London-Gatwick weather file. Figure 2 shows dissimilarity in cooling and heating loads for the two building fabrics. Best practice insulated building (BF2), as expected, has much lower heating demand, but on the other hand, cooling loads are nearly 60% higher in comparison with low-level insulated building (BF1). This anti-insulation behaviour in building energy consumption has already been reported by Masoso (2008) and this fact can be additionally explained by analysing Figure 3, which presents results for a three-day simulation period with starting day on Sunday 7th May. Two curves in the top part of the graph show indoor temperature profile for the first floor office zone (F1Z1) while in the bottom part of the graph the zone cooling/heating

sensible energy profiles are presented. The results clearly suggest that BF2 building requires cooling each day, including Sunday when the indoor temperature is maintained at 28°C. Also, in this period, BF2 has no requirements for heating at all. On the other hand, BF1 has to be heated during morning hours and cooled only during the afternoon of the last day but with significantly lower intensity than BF2. The reasons for higher cooling loads of well-insulated building are mainly caused by direct solar radiation through windows which is absorbed by the building construction. Better insulation increases building thermal inertia which can be seen in Figure 4, where the top two lines presents the internal surface temperature profile of the west oriented external wall. The graph shows that the wall insulated according to the best practice has up to 8°C higher inside surface temperature. This results in significantly higher convective heat gains to the indoor air which is represented by dashed lines in the same graph.

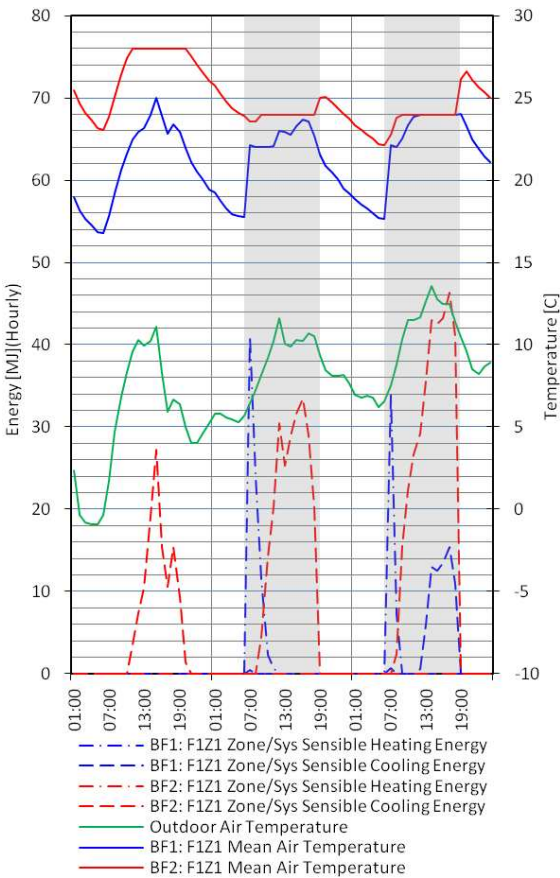

Figure 3. F1Z1 Cooling/Heating load and temperature profile.

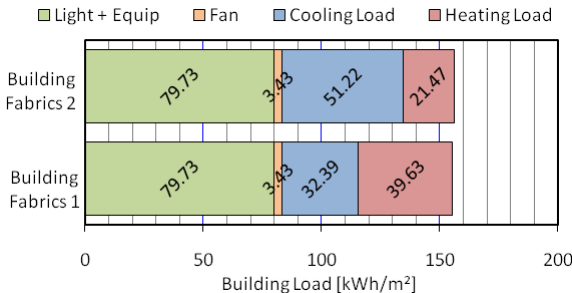

Figure 2. Building load.

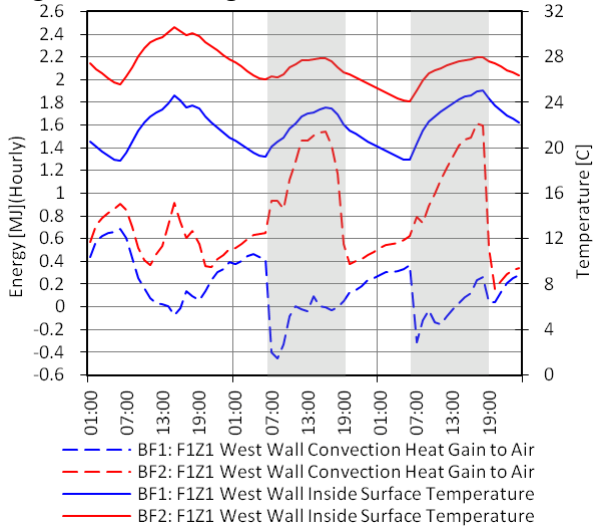

Figure 4. External wall inside surface temperature profile and convection heat gain.

Figure 5 shows building heating/cooling loads for three three-day periods which are extracted from the annual simulation. Each of these three periods starts on a Sunday and represents the building thermal behaviour during winter season (19-21 February), intermediate season (7-9 May) and summer season (24-27 Jun) respectively. The low level insulated building, BF1, has significantly higher heating demand during the winter. Moreover, during the unoccupied hours, BF1 demonstrates need for heating to keep the indoor air temperature over 12°C, which is a setback temperature. On the other hand, during the summer period, the cooling demand of the best practice insulated building, BF2, is higher compared to the cooling demand of BF1 building. This is particularly evident during the unoccupied hours where the BF2 cooling demand is up to 70% higher. As already mentioned, in intermediate period, BF1 and BF2 buildings behave quite differently. The first one has higher heating demand and occasional needs for cooling, while the second one operates mainly in the cooling mode.

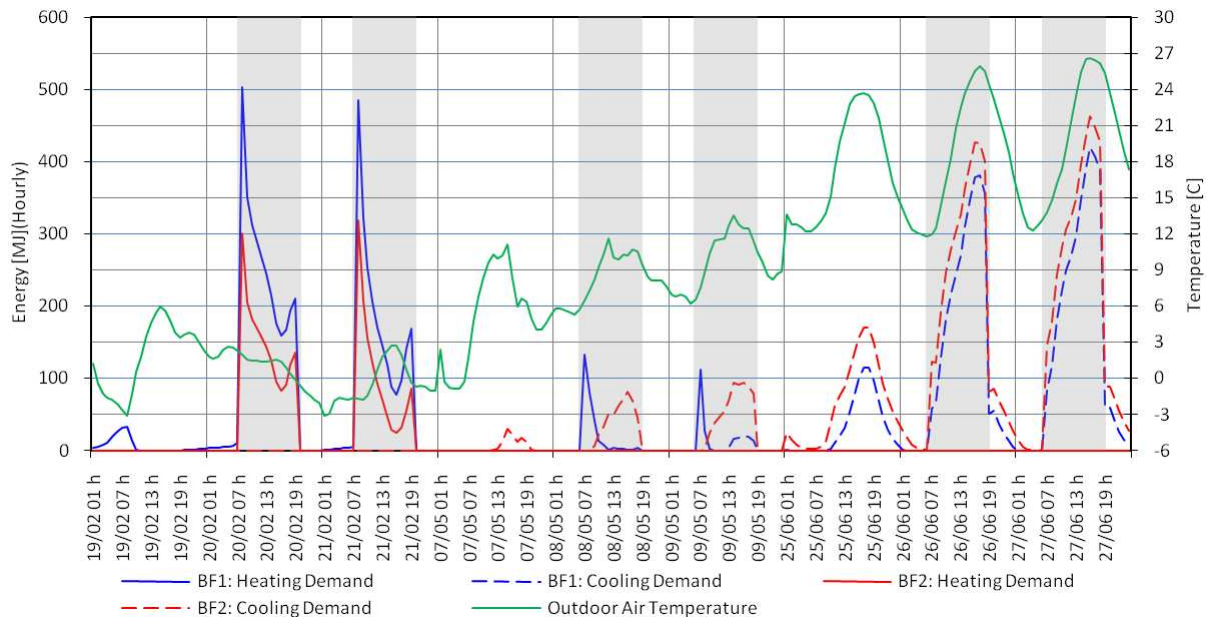

Figure 5. Heating/cooling demand during winter/intermediate/summer season.

HVAC System Models

The main question in this paper is how typical HVAC systems handle these different building loads. For that purpose, the two most common HVAC systems have been coupled with this building. First system is Variable Air Volume System (VAV) while the second system is Constant Air Volume System (CAV). Both systems are equipped with zone reheating boxes.

VAV System is an air system that varies its supply air volume rate, while keeping a supply air temperature constant, to match the reduction of space load during part-load, to maintain a predetermined space parameter, usually air temperature, and to conserve fan power at reduced volume flow. Main heating and cooling coils are controlled by a temperature sensor located in the supply air stream, t_{sa} in Figure 6. This temperature can have high impact on system energy consumption which is why two setpoint values have been analysed: 16°C and 18°C. The air reheating box is composed of a damper and hot water coil, both operated by zone temperature sensor (t_{za}), with a reverse damper action. This means that in the heating mode unit starts at minimum air flow and minimum hot water flow. With a load increment, the hot water flow is increased until it reaches maximum flow, then the air damper starts to open to meet the load.

In contrast to the VAV system, CAV system (Figure 7) keeps the air volume flow rate constant while varies its supply air temperature (t_{sa}) according to the cooling demand of the warmest zone. This strategy, in comparison with the CAV system with constant supply air temperature, minimizes zone reheat coil energy or overcooling.

Amount of the outdoor air for both systems is controlled via the outdoor air mixing box with two different control strategies. The first control strategy provides only the amount of the outdoor air necessary to satisfy fresh air requirements. The second strategy increases this amount whenever is possible to benefit from free cooling. This is achieved by using an airside economizer which mixes return air and outdoor air in certain proportions to meet the mixed air temperature setpoint (t_{ma}).

Initially, in order to focus primarily on the effects of secondary HVAC system only, it was assumed that the infinite amount of cooling/heating energy is available all the time which is

why district cooling/heating with assumed 100% efficiency have been chosen as primary energy sources. The following HVAC systems have been coupled firstly to the building with low level of insulation (BF1) and lately to the best practice insulated building (BF2):

- VAV System with fixed amount of outdoor air
- VAV System with airside economizer
- CAV System with fixed amount of outdoor air
- CAV System with airside economizer

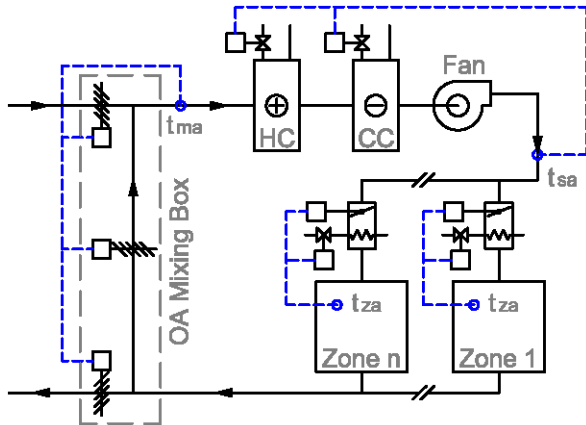

Figure 6. Variable Air Volume System.

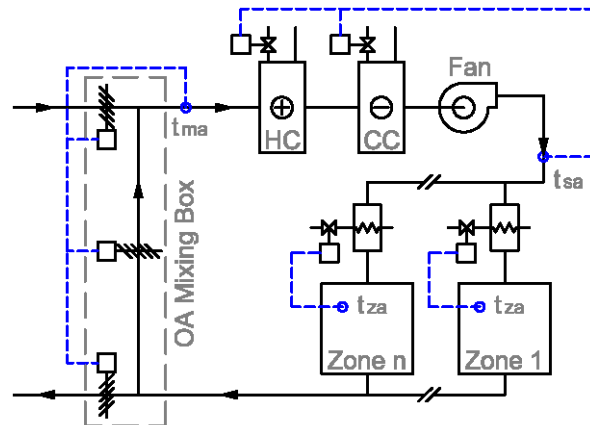

Figure 7. Constant Air Volume System.

RESULTS AND DISCUSSION

Different systems energy consumptions are presented in Figure 8: the two most apparent results concern cooling and fan energy. The systems with a fixed amount of outdoor air, when compared to the systems with installed outdoor air economizer, have significantly higher cooling demands. These cooling demands are around two and a half times higher for the VAV systems and go up to more than four times for the CAV systems. At the same time, outdoor air economizer has negligible effect on the heating demand. The fan energy consumption of the CAV systems is nearly doubled in comparison to the fan consumption of the VAV systems.

More detailed analysis of the presented graph discovers that a heating energy consumption of the CAV systems is slightly lower than that of the VAV systems. This difference occurs due to different quantities of air which these systems handle during the heating period. The VAV system operates with a minimum amount of air while the CAV system handles maximum air flow rate. This air heats up for around 1°C by absorbing the fan dissipative energy. More air volume, which passes through the fan, absorbs more heat, which results in decreased demand for reheating in zone terminal boxes, and finally in reduction of a total heat demand.

Another very important finding is related to the selection of the supply air temperature. Comparing VAV systems with different supply air temperatures, 16°C and 18°C , leads to the conclusion that systems with higher supply air temperature have lower cooling demand. This is particularly evident in the systems with the outdoor air economizer where the cooling demand is decreased up to 25%. The confirmation of this can be found by observing the CAV system cooling demand, which is the lowest one. This is due to the CAV system being controlled by variable supply air temperature, which is, whenever it is possible, higher than 18°C . In this way, the CAV system maximises its benefit from a free cooling.

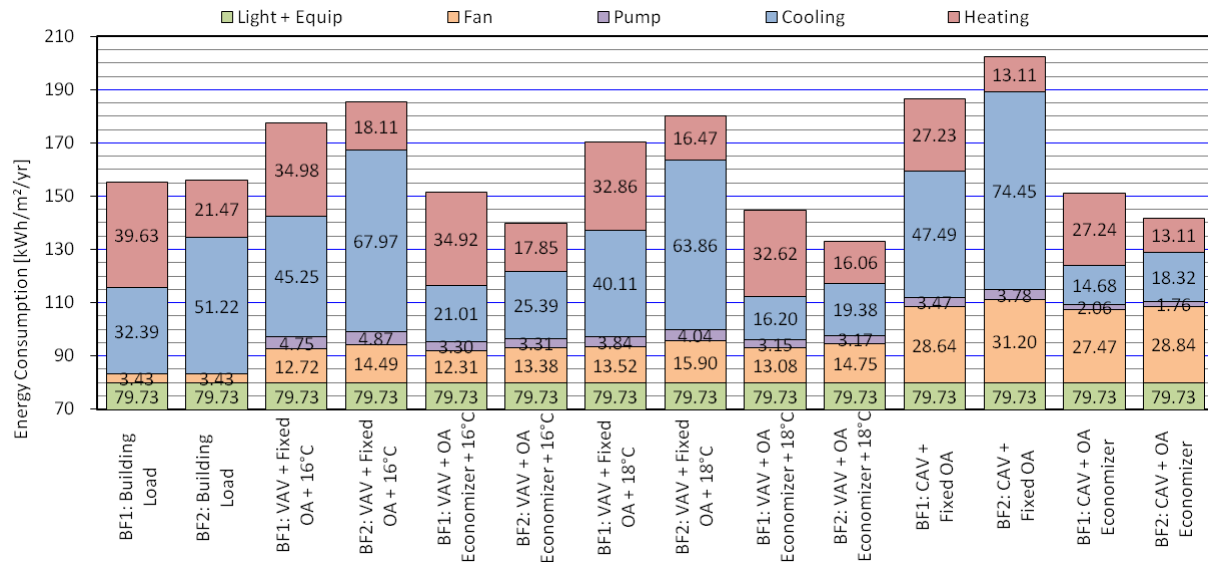

Figure 8. HVAC systems energy consumption.

The other interesting result is that a CAV system with outdoor air economizer performs equally well as VAV system with economizer and 16°C supply air temperature. To further investigate this effect, the original assumption of district heating and cooling has been replaced with grid electricity and natural gas. The Figure 9 shows results with cooling load converted to the electricity and the heating load converted to the natural gas consumption. It has been assumed that air-cooled chiller provides the cooling energy by operating with integrated part load value of 3.2. Heating energy is generated by a hot water gas boiler with 85% seasonal efficiency. Once connected to grid, CAV system has higher total energy consumption in comparison with the VAV system. This energy consumption increment ranges between 5 and 10 percent, depending mainly on building insulation level.

Also, it is important to mention that the natural gas consumption of each of simulated systems is far below the good practice benchmark, which is 97 kWh/m² (ECG019, 2003). The two main reasons for this are significant solar gains through windows and very high gains from internal sources. All other end users energy consumptions are within the good practice benchmark limits except electricity consumptions for lighting and office equipment which is very close to the typical benchmark.

An increasingly important way of comparing different HVAC systems performances is by analysing their CO₂ emissions, which are presented in Figure 9 by grey columns. CO₂ emission is calculated using the following green house gas conversion factors (DEFRA, 2008); for the natural gas - 0.185 kgCO₂/kWh and for the grid electricity – 0.537 kgCO₂/kWh. From this analysis follows that the VAV system with outdoor air economizer and 18°C supply air temperature has the lowest CO₂ emission and performs slightly better than the same system with a 16°C supply air temperature. The CAV system with economizer behaves very similar to the VAV systems with a fixed amount of outdoor air, while the CAV system with fixed amount of outdoor air has the highest CO₂ emission. Also should be noted that coupling of best practice insulated building with a systems with a fixed amount of outdoor air results in slightly higher CO₂ emission despite the significant reduction in heating demand. This is mainly due to the much higher cooling demand which is met by electricity. However, the use of an economizer changes this behaviour and enables reduced CO₂ emission of the BF2.

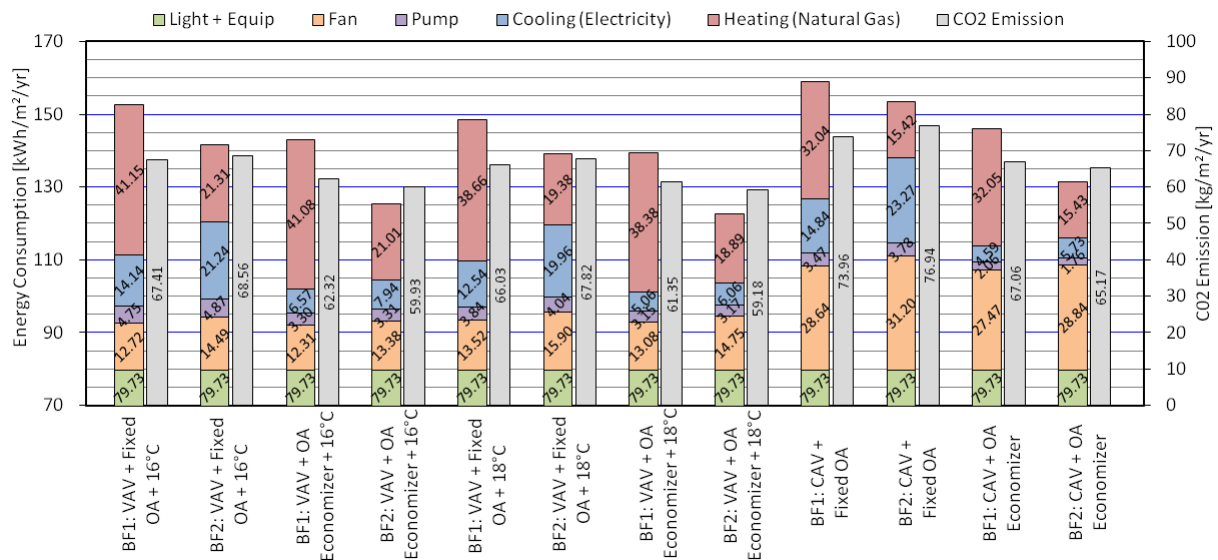

Figure 9. Primary energy consumption and CO2 emission.

Results presented in the last figure show that the influence of primary systems on the building total energy consumption cannot be neglected. In this case, a very simple comparison has been done by using only boiler seasonal efficiency and chiller integrated part load values. More in depth analysis should include changes in primary systems efficiencies affected by operation under part load conditions. This can only be obtained by simultaneous simulation of building, secondary system and primary system, but that is beyond the scope of this paper.

CONCLUSIONS

In this paper, some initial findings of the current project are presented. One of the early conclusions that can be drawn from this investigation is that, in the UK climate, better insulation to the building envelope may lead to increased cooling load in the summer. This is particularly significant when the building has a high glazing ratio and a high internal heat gain. The energy consumption associated with different HVAC systems, i.e. the VAV and CAV systems are compared. In general, the energy performance of the VAV system is better than the CAV system. Systems equipped with an airside economizer that adjusts outside air volume according to the heating and cooling demand and the ambient temperature have shown significant advantages over the fixed outside air systems. The energy saving was attributed to the reduction of cooling load by making use of the available free cooling.

In terms of annual energy consumption, the building fabric insulated to the best practice level combined with VAV system with economizer and higher overall air volume is the best performer. If carbon footprint is of consideration, the CO2 emission due to cooling is less significant compared to that of heating and fan consumptions. However, the calculation was carried out with the default chiller/boiler coefficient of performance and the green house gasses conversion factors for gas and electricity. The sensitivity of the selection of systems to these factors needs to be further investigated.

ACKNOWLEDGEMENT

The authors would like to acknowledge financial support of this work which forms part of the CITYNET project funded via the Marie Curie Research Training Network.

REFERENCES

- Al-Homoud, M.S. (1997) Optimum thermal design of office buildings. *International Journal of Energy Research*, **21**, 941–957.
- ASHRAE (2007) Handbook–HVAC Applications (SI), American Society of Heating, Refrigerating and Air–Conditioning Engineers, Inc., Atlanta, GA.
- Becker, R., and Paciuk, M. (2002) Inter-related effect of cooling strategies and building features on energy performance of office buildings. *Energy and Buildings*, **34**, 25–31.
- Cho, Y.H., and Liu, M. (2009) Single-duct constant volume system optimization. *Energy and Buildings*, **41(8)**, 856–862.
- CIBSE (2006) Guide A: Environmental design, Chartered Institution of Building Services Engineers, London, UK.
- CIBSE (2005) Guide B: Heating, Ventilating, Air Conditioning and Refrigeration, Chartered Institution of Building Services Engineers, London, UK.
- DEFRA (2008) Guidelines to Defra's GHG Conversion Factors.
- ECG019 (2003) Energy Efficiency–Best Practice Programme – Energy Consumption Guide 019: Energy Use in Offices, Carbon Trust.
- Eskin, N., Turkmen, H. (2008) Analysis of annual heating and cooling energy requirements for office buildings in different climates in Turkey. *Energy and Buildings*, **40**, 763–773.
- Masoso, O.T., Grobler, L.J. (2008) A new and innovative look at anti-insulation behaviour in building energy consumption. *Energy and Buildings*, **40**, 1889–1894.
- The Building Regulations (2006) Approved document F: Ventilation, Office of the Deputy Prime Minister, UK.
- The Building Regulations (1990) Approved document L: Conservation of fuel and power, Office of the Deputy Prime Minister, UK.
- The Building Regulations (2006) Approved document L2: Conservation of fuel and power, Office of the Deputy Prime Minister, UK.
- Yuan, S., Perez, R. (2006) Multiple-zone ventilation and temperature control of a single-duct VAV system using model predictive strategy. *Energy and Buildings*, **38**, 1248–1261.
- Zhang, Y., Wright, J. A., Hanby, V. I. (2006) Energy aspects of HVAC system configurations – problem definition and test cases, *HVAC&R Research Special Issue*, **12(3c)**, 871-888.