

**GUANINE NUCLEOTIDES IN ISCHAEMIC HEART**

by Peter Graham Stanley, MSc, MIBiol.

A thesis submitted for the degree of  
Doctor of Philosophy  
in the  
University of London

Department of Biochemistry  
and Molecular Biology,  
University College,  
Gower Street, London WC1E 6BT.

April, 1994

ProQuest Number: 10044465

All rights reserved

INFORMATION TO ALL USERS

The quality of this reproduction is dependent upon the quality of the copy submitted.

In the unlikely event that the author did not send a complete manuscript and there are missing pages, these will be noted. Also, if material had to be removed, a note will indicate the deletion.

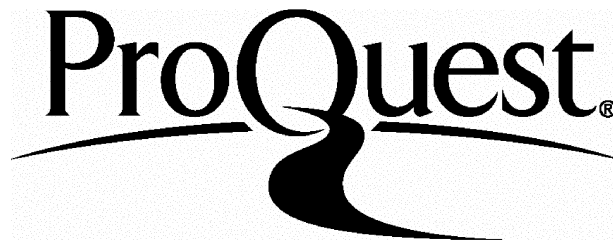

ProQuest 10044465

Published by ProQuest LLC(2016). Copyright of the Dissertation is held by the Author.

All rights reserved.

This work is protected against unauthorized copying under Title 17, United States Code.  
Microform Edition © ProQuest LLC.

ProQuest LLC  
789 East Eisenhower Parkway  
P.O. Box 1346  
Ann Arbor, MI 48106-1346

## GUANINE NUCLEOTIDES IN ISCHAEMIC HEART

by Peter Graham Stanley

### Abstract

In isolated perfused rat hearts the concentration of guanine nucleotides following periods of global no-flow ischaemia and reperfusion were found to parallel those of adenine nucleotides under all conditions tested. Short periods of ischaemia (up to 20 minutes) resulted in decreases of about 50% in both ATP and GTP concentration, with full recovery usually occurring after 10 minutes of reperfusion, while longer periods of ischaemia resulted in greater decreases in ATP and GTP and a lower rate of recovery on reperfusion. Similar results were observed in isolated rat myocytes subjected to periods of anoxia.

Discrepancies were noted in total guanine compounds following ischaemia; the changes to guanine nucleotides were apparently not balanced by corresponding changes to breakdown products (eg guanosine), in either perfused hearts or isolated myocytes.

The post-ischaemic/anoxic recovery of guanine nucleotides was unaffected by IMP-dehydrogenase inhibitors, suggesting that neither *de novo* synthesis nor the existing adenine nucleotide pool contributed significantly to the recovery.

No correlation was found between the GTP concentration or the GTP/GDP ratio and the post-ischaemic response of hearts to either adrenaline or carbachol, suggesting that neither GTP availability nor a depressed GTP/GDP ratio was acting as the rate-limiting factor in the signal transmission process.

## Acknowledgements

This work was funded by an SERC/CASE studentship in collaboration with SmithKline Beecham, Welwyn, Hertfordshire.

I am indebted to my PhD supervisor, Dr Iain Mowbray, for giving me the opportunity to carry out this work, and for his considerable help, advice, patience and friendship during the course of my studies.

I am also grateful to Dr Paul England of SmithKline Beecham for helpful comments and advice and for his part in provision of funding.

My thanks also to:- Ms Mary Sarcina and Mr Andreas Costi for their advice and expert technical assistance, Dr Brinda Patel for excellent instruction in many of the techniques used and for helpful comments and advice, Drs Louise Hardy, Martin Crompton and Wilma Nazareth for useful comments and advice concerning the isolation and incubation of myocytes, and other members of the department of Biochemistry and Molecular Biology, UCL, who have helped in various ways. Finally, to my family and friends for their patience and support during the undertaking of this project.

(My thanks to Ms Mary Sarcina and Drs Brinda Patel and Louise Hardy for their part in proof-reading the text, although any mistakes or omissions therein are entirely my responsibility).

| Contents  | Page   |
|---|--------|
| Abstract  | 2      |
| Acknowledgements  | 3      |
| Contents  | 4      |
| List of Figures and Tables  | 9      |
| Abbreviations   | 15     |
| <br>CHAPTER 1 INTRODUCTION  | <br>16 |
| 1.1 General introduction  | 16     |
| 1.2 Objectives  | 18     |
| 1.3 Guanine nucleotide metabolism in heart  | 18     |
| 1.3.1 <i>De novo</i> synthesis of guanine nucleotides                                   | 24     |
| 1.3.2 Synthesis of guanine nucleotides from adenine nucleotides and by salvage pathways | 26     |
| 1.3.3 GTP synthesis and control of guanine nucleotide ratios                            | 31     |
| 1.3.3.1 Nucleoside monophosphate kinase   | 32     |
| 1.3.3.2 Nucleoside diphosphate kinase   | 32     |
| 1.3.4 Guanine nucleotide breakdown  | 35     |
| 1.3.5 Effect of ischaemia on guanine nucleotides  | 36     |
| 1.4 Role of guanine nucleotides in heart  | 38     |
| 1.4.1 G-proteins and signal transmission  | 39     |
| 1.4.1.1 Structure and function of G-proteins  | 39     |
| 1.4.1.2 Guanine nucleotides and G-protein activity                                      | 43     |
| 1.4.1.3 Nucleoside diphosphate kinase and G-protein activity                            | 48     |
| 1.4.1.4 G-proteins and cardiac ischaemia  | 49     |
| 1.4.2 cGMP as a second messenger  | 52     |
| 1.4.2.1 Synthesis of cGMP   | 52     |

|                                 |   |    |
|---------------------------------|---|----|
| 1.4.2.2                         | Degradation of cGMP   | 54 |
| 1.4.2.3                         | Action of cGMP  | 55 |
| 1.4.3                           | GTP and membrane fusion   | 59 |
| 1.4.4                           | GTP and protein synthesis   | 61 |
| 1.4.5                           | Other roles of guanine nucleotides                                  | 63 |
| CHAPTER 2 MATERIALS AND METHODS |   | 64 |
| 2.1                             | Materials   | 64 |
| 2.1.1                           | Chemicals   | 64 |
| 2.1.2                           | Enzymes   | 65 |
| 2.1.3                           | Drugs and hormones  | 65 |
| 2.1.4                           | Animals   | 65 |
| 2.1.5                           | Other material  | 66 |
| 2.2                             | Statistical analysis  | 66 |
| 2.3                             | Heart perfusions  | 68 |
| 2.3.1                           | Media   | 68 |
| 2.3.2                           | Perfusion apparatus   | 69 |
| 2.3.3                           | Perfusion procedure   | 74 |
| 2.3.3.1                         | Conditions  | 74 |
| 2.3.3.2                         | Heart cannulation and perfusion                                     | 74 |
| 2.3.3.3                         | Introducing ischaemia   | 77 |
| 2.3.3.4                         | Application of drugs and hormones                                   | 77 |
| 2.3.3.5                         | Electrical pacing   | 77 |
| 2.4                             | Measurement of heart beat rate and amplitude                        | 78 |
| 2.5                             | Measurement of oxygen consumption by perfused heart                 | 84 |
| 2.6                             | Homogenisation and extraction of tissue                             | 85 |
| 2.7                             | Measurement of purine nucleotides, nucleosides and bases using HPLC | 88 |

|           |  |     |
|-----------|--|-----|
| 2.7.1     | Anion-exchange HPLC  | 88  |
| 2.7.2     | Reverse-phase HPLC   | 90  |
| 2.8       | Measurement of cGMP by radioimmunoassay  | 97  |
| 2.9       | Experiments on isolated myocytes   | 104 |
| 2.9.1     | Isolation of myocytes  | 104 |
| 2.9.1.1   | Media  | 107 |
| 2.9.1.2   | Perfusion and cell dissociation  | 107 |
| 2.9.1.3   | Cell purification  | 109 |
| 2.9.1.4   | Determination of yield and viability   | 109 |
| 2.9.2     | Incubation of myocytes   | 111 |
| 2.9.3     | Extraction of tissue and measurement of purines  | 112 |
| CHAPTER 3 | HEART PERFUSIONS - RESULTS AND DISCUSSION  | 113 |
| 3.1       | Conditions of perfusion and normalisation of data  | 113 |
| 3.2       | Effect of ischaemia on purine nucleotides (series 1)   | 114 |
| 3.2.1     | Effect of ischaemia on adenine nucleotides and breakdown products                                | 115 |
| 3.2.2     | Effect of ischaemia on guanine nucleotides   | 127 |
| 3.3       | Effect of ischaemia and increased workload on purine nucleotides (series 2)                      | 134 |
| 3.3.1     | Effect of ischaemia and workload on adenine nucleotides and breakdown products                   | 135 |
| 3.3.2     | Effect of ischaemia and workload on guanine nucleotides  | 141 |
| 3.4       | Effect of longer-term ischaemia and reperfusion on purine nucleotides (series 3, 4 and 5)        | 146 |
| 3.4.1     | Effect of longer-term ischaemia on ATP, GTP and nucleotide ratios                                | 146 |
| 3.4.2     | Effect of longer periods of reperfusion on adenine nucleotides and breakdown products (series 3) | 152 |

|   |   |     |
|---|---|-----|
| 3.4.3                                       | Effect of longer periods of reperfusion on guanine nucleotides  | 159 |
| 3.4.4                                       | Summary of the effects of increased periods of ischaemia and reperfusion                                      | 166 |
| 3.5   | The source of post-ischaemic guanine nucleotide recovery  | 167 |
| 3.6   | Effect of IMP-dehydrogenase inhibitors on post-ischaemic recovery of guanine nucleotides (series 8, 9 and 10) | 169 |
| 3.6.1                                       | Mycophenolic acid (series 8)  | 169 |
| 3.6.2                                       | 6-mercaptapurine ribonucleotide (series 9)  | 170 |
| 3.6.3                                       | Ribavirin (series 10)   | 175 |
| 3.6.4                                       | Conclusions   | 176 |
| 3.7   | Effect of post-ischaemic changes in GTP content on GTP-dependent responses to drugs                           | 179 |
| 3.7.1                                       | Effect of GTP content on post-ischaemic response to adrenaline  | 180 |
| 3.7.1.1                                     | GTP content and metabolic response to adrenaline (series 9)   | 181 |
| 3.7.1.2                                     | GTP content and mechanical response to adrenaline at increased workload (series 10)                           | 188 |
| 3.7.1.3                                     | Conclusions   | 193 |
| 3.7.2                                       | Effect of ischaemia on response to carbachol (series 11 and 12)   | 194 |
| CHAPTER 4 MYOCYTES - RESULTS AND DISCUSSION |   | 205 |
| 4.1   | Development of method for isolation of viable rat cardiac myocytes (series 1 and 2)                           | 205 |
| 4.2   | Effect of anoxia and ribavirin on purine nucleotides in isolated rat myocytes (series 3)                      | 212 |
| 4.2.1                                       | Effect of anoxia on adenine nucleotides and breakdown products  | 214 |



|  |   |     |
|--|---|-----|
| 4.2.2  | Effect of anoxia on guanine nucleotides and guanosine                                       | 224 |
| 4.2.3  | Effect of ribavirin on post-anoxic recovery of guanine nucleotides in isolated rat myocytes | 227 |
| 4.3  | Conclusions   | 228 |
| CHAPTER 5 CONCLUSIONS AND GENERAL DISCUSSION |   | 229 |
| 5.1  | Conclusions   | 229 |
| 5.2  | Guanine nucleotides and ischaemia   | 230 |
| 5.3  | Guanine nucleotides and metabolic regulation  | 233 |
| 5.4  | Clinical relevance  | 237 |
| References                                   |   | 240 |

| Figures and Tables  | Page |
|---|------|
| <u>Figures</u>  |      |
| 1.1 Purine nucleotide metabolism in heart   | 22   |
| 1.2 G-proteins and control of cardiac output  | 42   |
| 2.1 Diagrammatic representation of the perfusion apparatus  | 72   |
| 2.2 Diagrammatic representation of the modified cannula assembly  | 81   |
| 2.3 Heart beat record of perfused heart treated with $10^{-7}$ M adrenalin  | 83   |
| 2.4 Oxygen electrode trace during a heart perfusion   | 87   |
| 2.5 Anion-exchange HPLC profile of purine nucleotide standards  | 93   |
| 2.6 Anion-exchange HPLC profiles of TCA-soluble extract of perfused rat hearts  | 94   |
| 2.7 Reverse-phase HPLC profile of TCA-soluble extract of perfused rat heart   | 96   |
| 2.8 Standard curve for cGMP radioimmunoassay  | 102  |
| 2.9 Measurement of cGMP in heart extracts by the radioimmunoassay   | 103  |
| 3.1 Effect of ischaemia and reperfusion on adenine nucleotides in isolated perfused rat hearts (series 1)                         | 120  |
| 3.2 Effect of ischaemia and reperfusion on total adenine nucleotides and ATP/ADP ratio in isolated perfused rat hearts (series 1) | 121  |
| 3.3 Effect of ischaemia and reperfusion on guanine nucleotides in isolated perfused rat hearts (series 1)                         | 131  |
| 3.4 Effect of ischaemia and reperfusion with increased workload on adenine nucleotides in isolated perfused rat hearts (series 2) | 140  |
| 3.5 Effect of ischaemia and reperfusion with increased workload on guanine nucleotides in isolated perfused rat hearts (series 2) | 145  |

|      |   |     |
|------|---|-----|
| 3.6  | Effect of various periods of ischaemia and reperfusion with increased workload on ATP content and ATP/ADP ratio of isolated perfused rat hearts (series 3, 4 and 5) | 149 |
| 3.7  | Effect of various periods of ischaemia and reperfusion with increased workload on GTP content and GTP/GDP ratio of isolated perfused rat hearts (series 3, 4 and 5) | 150 |
| 3.8  | Correlation of post-ischaemic ATP and GTP content of isolated perfused rat hearts subjected to increased workload (series 2 and 3)                                  | 164 |
| 3.9  | Correlation of post-ischaemic ATP/ADP and GTP/GDP of isolated perfused rat hearts subjected to increased workload (series 2 and 3)                                  | 165 |
| 3.10 | Effect of mycophenolic acid on the post-ischaemic recovery of guanine nucleotides in isolated perfused rat hearts (series 6)  | 172 |
| 3.11 | Effect of 6-mercaptopurine-ribonucleotide on the post-ischaemic recovery of guanine nucleotides in isolated perfused rat hearts (series 7)                          | 174 |
| 3.12 | Effect of ribavirin on the post-ischaemic recovery of guanine nucleotides in isolated perfused rat hearts (series 8)  | 178 |
| 3.13 | Correlation of post-ischaemic GTP content and inotropic response to adrenalin of isolated perfused rat hearts (series 9)  | 185 |
| 3.14 | Correlation of post-ischaemic GTP content and chronotropic response to adrenalin of isolated perfused rat hearts (series 9)   | 186 |
| 3.15 | Correlation of post-ischaemic GTP content and changes in oxygen consumption in response to adrenalin of isolated perfused rat hearts (series 9)                     | 187 |
| 3.16 | Correlation of post-ischaemic GTP content and inotropic response to adrenalin of isolated perfused rat hearts subjected to increased workload (series 10)           | 191 |
| 3.17 | Correlation of post-ischaemic GTP content and chronotropic response to adrenalin of isolated perfused rat hearts subjected to increased workload (series 10)        | 192 |

|      |   |     |
|------|---|-----|
| 3.18 | Correlation of post-ischaemic GTP and cGMP content in response to carbachol in isolated perfused rat hearts subjected to increased workload (series 11) | 200 |
| 3.19 | Correlation of post-ischaemic GTP and cGMP content in response to carbachol in isolated perfused rat hearts subjected to increased workload (series 12) | 201 |
| 4.1  | Effect of anoxia and ribavirin on adenine nucleotides in isolated rat cardiac myocytes  | 220 |
| 4.2  | Effect of anoxia and ribavirin on total adenine nucleotides and ATP/ADP ratio in isolated rat cardiac myocytes  | 221 |
| 4.3  | Effect of anoxia and ribavirin on guanine nucleotides in isolated rat cardiac myocytes  | 222 |
| 4.4  | Effect of anoxia and ribavirin on total guanine nucleotides + guanosine and the GTP/GDP ratio in isolated rat cardiac myocytes                          | 223 |

| <u>Tables</u> |   | <u>Page</u> |
|---------------|---|-------------|
| 1.1           | Concentration of guanine nucleotides in heart   | 20          |
| 1.2           | Concentration of guanine nucleotides in isolated rat cardiac myocytes   | 20          |
| 1.3           | Concentration of cGMP in isolated perfused rat hearts   | 20          |
| 1.4           | G-proteins found in heart   | 41          |
| 3.1           | Effect of ischaemia and reperfusion on adenine nucleotides in isolated perfused rat hearts (series 1)           | 118         |
| 3.2           | Effect of ischaemia and reperfusion on IMP, adenosine and inosine in isolated perfused rat hearts (series 1)    | 119         |
| 3.3           | Effect of ischaemia and reperfusion on guanine nucleotides in isolated perfused rat hearts (series 1)           | 130         |
| 3.4           | Correlation between ATP and GTP concentrations and nucleotide ratios in isolated perfused rat hearts (series 1) | 130         |

|      |   |     |
|------|---|-----|
| 3.5  | Effect of ischaemia and reperfusion with increased workload on adenine nucleotides in isolated perfused rat hearts (series 2)                           | 139 |
| 3.6  | Effect of ischaemia and reperfusion with increased workload on IMP, adenosine and inosine in isolated perfused rat hearts (series 2)                    | 139 |
| 3.7  | Effect of ischaemia and reperfusion with increased workload on guanine nucleotides in isolated perfused rat hearts (series 2)                           | 144 |
| 3.8  | Correlation between ATP and GTP concentrations and nucleotide ratios in isolated perfused rat hearts subjected to increased workload (series 2)         | 144 |
| 3.9  | Effect of ischaemia and various periods of reperfusion with increased workload on adenine nucleotides in isolated perfused rat hearts (series 3)        | 155 |
| 3.10 | Effect of ischaemia and various periods of reperfusion with increased workload on IMP, adenosine and inosine in isolated perfused rat hearts (series 3) | 156 |
| 3.11 | Amount of inosine in the perfusate from rat hearts subjected to ischaemia and increased workload (series 3)   | 157 |
| 3.12 | Effect of ischaemia and various periods of reperfusion with increased workload on guanine nucleotides in isolated perfused rat hearts (series 3)        | 160 |
| 3.13 | Correlation between ATP and GTP concentrations and nucleotide ratios in isolated perfused rat hearts subjected to increased workload (series 3)         | 161 |
| 3.14 | Correlation between ATP and GTP concentrations and nucleotide ratios in isolated perfused rat hearts subjected to increased workload (series 2 and 3)   | 163 |
| 3.15 | Effect of ischaemia on metabolic response to adrenalin (summary of all 11 hearts of series 9)   | 183 |
| 3.16 | Correlation between nucleotide content or ratio and post-ischaemic response to adrenalin (series 9)   | 184 |

|      |   |     |
|------|---|-----|
| 3.17 | Correlation between nucleotide content or ratio and difference between pre- and post-ischaemic response to adrenalin (series 9)                                   | 184 |
| 3.18 | Effect of ischaemia on mechanical response to adrenaline at increased workload (summary of 7 hearts of series 10)   | 190 |
| 3.19 | Correlation between nucleotide content or ratio and post-ischaemic mechanical response to adrenalin at increased workload (series 10)                             | 189 |
| 3.20 | Correlation between nucleotide content or ratio and difference between pre- and post-ischaemic mechanical response to adrenalin at increased workload (series 10) | 190 |
| 3.21 | Effect of carbachol on cGMP concentration following ischaemia and increased workload in isolated perfused rat hearts (series 11 and 12)                           | 197 |
| 3.22 | Correlation between post-ischaemic content of cGMP and other purine nucleotides and ratios after perfusion of rat hearts with carbachol (series 11 and 12)        | 198 |
| 3.23 | Correlation between post-ischaemic ATP and GTP and between nucleotide ratios after perfusion of rat hearts with carbachol (series 11 and 12)                      | 199 |
| 4.1  | Yield of rod-shaped viable rat cardiac myocytes isolated using different resuspension buffers   | 208 |
| 4.2  | Concentration of ATP in isolated rat cardiac myocytes incubated in different buffers  | 208 |
| 4.3  | ATP/ADP ratio in isolated rat cardiac myocytes incubated in different buffers   | 209 |
| 4.4  | Concentration of GTP in isolated rat cardiac myocytes incubated in different buffers  | 209 |
| 4.5  | Effect of anoxia and ribavirin on adenine nucleotides in isolated rat cardiac myocytes  | 217 |
| 4.6  | Effect of anoxia and ribavirin on adenine nucleotide breakdown products in isolated rat cardiac myocytes  | 218 |
| 4.7  | Effect of anoxia and ribavirin on guanine nucleotides and guanosine in isolated rat cardiac myocytes  | 219 |

4.8 Correlation between ATP and GTP and  
nucleotide ratios in isolated rat cardiac  
myocytes

219

## Abbreviations

|                 |   |
|-----------------|---|
| A               | absorbance (subscript denotes wavelength in nanometers) |
| ADO             | Adenosine   |
| ADP             | Adenosine 5'-diphosphate                                |
| AMP             | Adenosine 5'-monophosphate                              |
| AN              | Adenine nucleotides (ATP+ADP+AMP)                       |
| ATP             | Adenosine 5'-triphosphate                               |
| Asp             | Aspartate   |
| BSA             | Bovine serum albumin                                    |
| cAMP            | Adenosine 3':5'-cyclic monophosphate                    |
| cGMP            | Guanosine 3':5'-cyclic monophosphate                    |
| Ci              | Curie   |
| c.p.m.          | counts/min.   |
| DNA             | deoxyribonucleic acid                                   |
| d.p.m.          | disintegrations/min.                                    |
| Fum             | Fumarate  |
| GDP             | Guanosine 5'-diphosphate                                |
| Gln             | Glutamine   |
| Glu             | Glutamate   |
| GMP             | Guanosine 5'-monophosphate                              |
| GN              | Guanine nucleotides (GTP+GDP+GMP)                       |
| GNO             | Guanosine   |
| GTP             | Guanosine 5'-triphosphate                               |
| H.P.L.C.        | High pressure (performance) liquid chromatography       |
| HX              | Hypoxanthine  |
| IMP             | Inosine 5'-monophosphate                                |
| INO             | Inosine   |
| IP <sub>3</sub> | Inositol-1,4,5-triphosphate                             |
| Km              | Michaelis constant                                      |
| kD              | Kilo Dalton   |
| NAD(P)+         | Nicotinamide-adenine dinucleotide (phosphate), oxidised |
| NAD(P)H         | Nicotinamide-adenine dinucleotide (phosphate), reduced  |
| n.m.r.          | Nuclear magnetic resonance                              |
| OPG-ATP         | Oligophosphoglyceroyl-ATP                               |
| PG-ATP          | Phosphoglyceroyl-ATP (monomer)                          |
| Pi              | Orthophosphate (inorganic)                              |
| PLC             | Phospholipase C   |
| PPi             | Pyrophosphate (inorganic)                               |
| PRPP            | 5'-phosphoribosyl-1-pyrophosphate                       |
| RNA             | Ribonucleic acid  |
| R-1-P           | Ribose-1-phosphate                                      |
| S-AMP           | Adenylosuccinate  |
| TCA             | Trichloroacetic acid                                    |
| v/v             | volume/volume   |
| w/v             | weight/volume   |
| w/w             | weight/weight   |
| wt.             | weight  |
| XAN             | Xanthine  |
| XMP             | Xanthosine 5'-monophosphate                             |



## CHAPTER 1 INTRODUCTION

### 1.1 General introduction

Research into the metabolic effects of cardiac ischaemia has focused on changes in adenine nucleotide content, as a high ATP concentration and ATP/ADP ratio are essential for cell survival and function (Jennings and Steenbergen, 1985). In contrast, little has been done to examine the effect of ischaemia on guanine nucleotides, although previous work in this laboratory has shown that changes to guanine nucleotides following brief ischaemia in Langendorff perfused rat hearts do not always parallel those of adenine nucleotides (Mowbray et al., 1981; 1984). Post-ischaemic changes in guanine nucleotide content may have important consequences for the regulation of cardiac function and require further study.

Guanine nucleotides are required for several cellular processes such as protein synthesis, signal transmission and membrane fusion. Any of these processes may therefore be impaired following post-ischaemic guanine nucleotide depletion. However, unlike many processes requiring ATP, those requiring GTP do not need to function continuously for cell survival and could therefore be temporarily down-regulated to save energy during periods of stress. This

could be achieved by allowing the GTP content or GTP/GDP ratio to fall to below the point at which it is the rate-limiting factor, whilst preserving the ATP content and ATP/ADP ratio as high as possible. This would require the concentrations and ratios of adenine and guanine nucleotides to be regulated independently, and the previous observations in this laboratory may be evidence of this.

The production of the second messengers cAMP and cGMP is dependent on GTP. Post-ischaemic rises in cAMP have been associated with cardiac arrhythmias (Corr et al., 1978), while cGMP may have a protective effect (Billman, 1990). Also, many chemical messengers and drugs exert their effect on the heart via these second messengers. Therefore knowledge of how post-ischaemic GTP depletion may effect their concentrations would be important for the management of ischaemic heart disease.

The post-ischaemic recovery of purine nucleotide content depends mainly on salvage pathways. There is evidence of compartmentation of these pathways in the heart, with endothelial cells playing an important role (Manfredi and Holmes, 1985). However, the role of different cell types in post-ischaemic guanine nucleotide recovery has not been studied in detail.

## 1.2 Objectives

The objectives of this project are therefore:-

(i) To establish conditions under which cardiac guanine nucleotide concentrations are consistently changed and regulated independently of those of adenine nucleotides.

(ii) To examine the effect of such changes on GTP-dependent processes.

(iii) To begin examining the role of different heart cell types in the metabolism of guanine nucleotides during and after stress.

## 1.3 Guanine nucleotide metabolism in heart

Under normal oxygenated conditions, cardiac GTP content and GTP/GDP ratio are held sufficiently high to drive GTP-dependent reactions. The guanine nucleotide content is maintained by balancing the rates of synthesis and degradation in a manner analogous to that for adenine nucleotides, while the GTP/GDP ratio is maintained by nucleoside diphosphate kinase (Parks and Agarwal, 1973).

The concentration of GTP measured in isolated rat hearts and in hearts of open-chested dogs is usually in the range 150-200 nmoles/g wet weight, equivalent to an intracellular concentration of about 300-400  $\mu\text{M}$  (table 1.1). This is approximately 5% of the ATP concentration. The rather large

range of values reported by Bates et al., (1978) was due to post-ischaemic synchronous fluctuations similar to those observed for adenine nucleotides. There is evidence that much of the GTP is bound or compartmentalised (Otero, 1990), and this is discussed in section 1.4.1. The concentration of GDP in rat hearts is 70-100 nmoles/g wet weight, resulting in a typical GTP/GDP ratio of 2-3. As for ADP, much of the GDP may be bound, so the measured ratio may not reflect the free GTP/GDP ratio (Kohn et al., 1977). There appear to be no measurements of GMP in whole hearts.

The basal concentration of cGMP in perfused rat hearts usually lies in the range 20-40 pmole/g wet wt. (table 1.3) and appears to undergo synchronous fluctuations similar to those observed for other purine nucleotides. cGMP content increases about three-fold in response to acetylcholine (George et al., 1970, 1973; Gardner and Allen, 1976).

The concentration of guanine nucleotides measured in isolated rat myocytes is shown in table 1.2. Using a conversion factor of 30 mg wet weight/ $10^6$  cells (Dow et al., 1981), the GTP concentration was equivalent to about 75 and 120 nmole/g wet weight of tissue for the results of Geisbuhler et al. and Altschuld et al. respectively. These are substantially lower than the values for whole hearts. Furthermore, the GTP content in these two studies was only about 2.6% of the corresponding ATP content (compared with 5% in whole hearts), suggesting that there was preferential

**Table 1.1** *Concentration of guanine nucleotides in heart (nmole/g wet weight)\**

| Preparation | GTP     | GDP | Reference                  |
|-------------|---------|-----|----------------------------|
| isolated )  | 200     | 100 | Deuticke & Gerlach, (1966) |
| perfused )  | 120-190 | 70  | Bates et al., (1978)       |
| rat heart)  | 160     |     | Harmsen et al., (1984)     |
| open- )     | 170     | -   | Swain et al., (1982a)      |
| chested )   | 180-190 | -   | Swain et al., (1982b)      |
| dog )       |         |     |                            |

\* Where values were originally expressed as quantity per gram dry weight, they have been converted to quantity per gram wet weight by dividing by 6 (Mowbray and Ottaway, 1973).

**Table 1.2** *Concentration of guanine nucleotides in isolated rat cardiac myocytes (nmole/10<sup>6</sup> cells)\**

| GTP | GDP | GMP | Reference                |
|-----|-----|-----|--------------------------|
| 2.2 | 2.7 | 0.4 | Geisbuhler et al. (1984) |
| 3.5 | -   | -   | Altschuld et al. (1987)  |

\* Where values were originally expressed as quantity per mg protein, they have been converted to quantity per million cells using a conversion factor of 5.7 mg protein/10<sup>6</sup> cells (Dow et al., 1981).

**Table 1.3** *Concentration of cGMP in isolated perfused rat hearts (pmole/g wet wt.)*

| cGMP  | Reference                      |
|-------|--------------------------------|
| 120   | George et al., (1970)          |
| 10-40 | Mowbray et al., (1975)         |
| 20    | Gardner & Allen, (1976)        |
| 25-45 | Bates et al., (1978)           |
| 20-40 | Mowbray et al., (1981), (1984) |

Legend to figure 1.1.

- (1) Adenylate kinase (EC 2.7.4.3)
- (2) 5'-nucleotidase (EC 3.1.3.5)
- (3) Adenosine kinase (EC 2.7.1.20)
- (4) AMP deaminase (EC 3.5.4.6)
- (5) Adenosine deaminase (EC 3.5.4.4)
- (6) Purine nucleoside phosphorylase (EC 2.4.2.1)
- (7) Adenylosuccinate synthetase (EC 6.3.4.4)
- (8) Adenylosuccinate lyase (EC 4.3.2.2)
- (9) IMP dehydrogenase (EC 1.2.1.14)
- (10) GMP synthetase (EC 6.3.4.1)
- (11) Nucleoside monophosphate kinase (EC 2.7.4.8)
- (12) Nucleoside diphosphate kinase (EC 2.7.4.6)
- (13) Adenine phosphoribosyltransferase (EC 2.4.2.7)
- (14) Hypoxanthine/guanine phosphoribosyltransferase  
(EC 2.4.2.8)
- (15) Guanine deaminase (EC 3.5.4.3)
- (16) Xanthine oxidase (EC 1.2.3.2)

ADO = Adenosine  
INO = Inosine  
GNO = Guanosine  
HX = Hypoxanthine  
XAN = Xanthine  
S-AMP = Adenylosuccinate

Figure 1.1 Purine nucleotide metabolism in heart

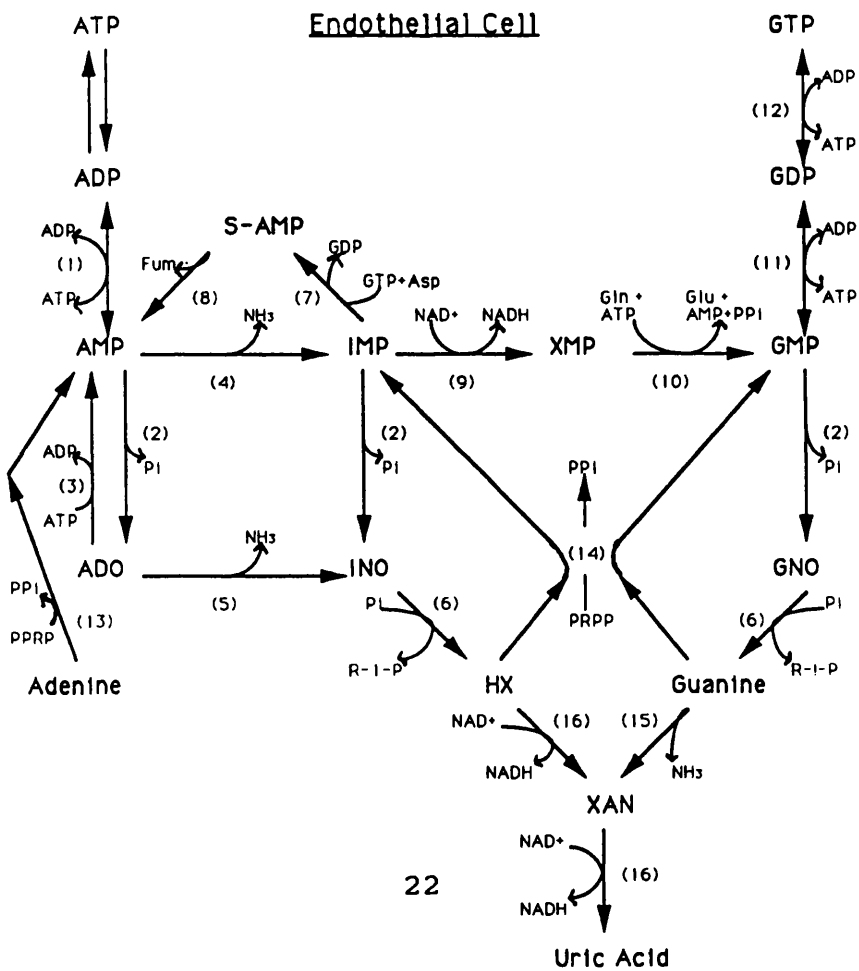
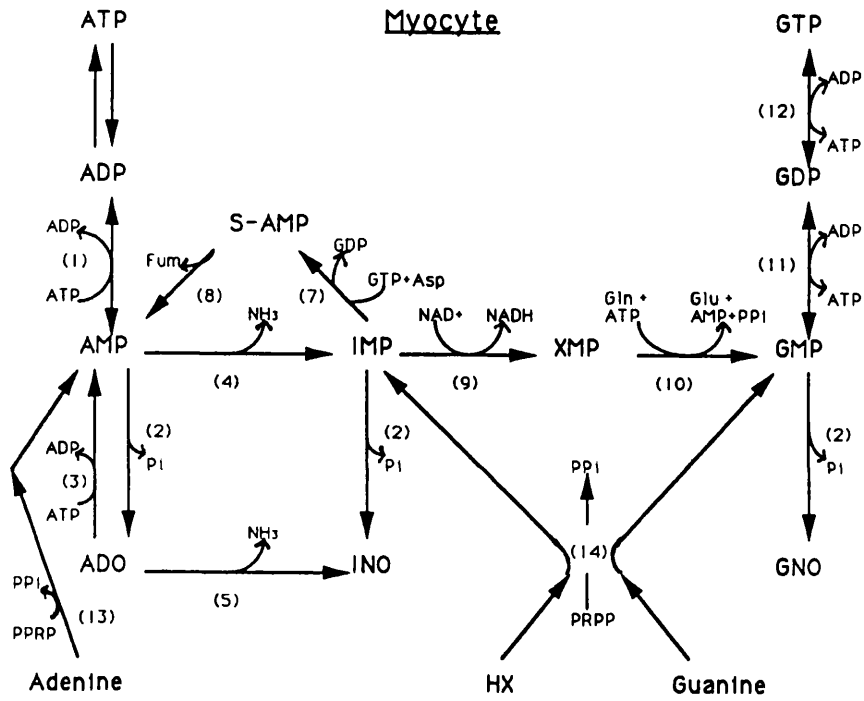

loss of GTP in these preparations; an idea supported by the low GTP/GDP ratio of 0.8 seen in the Geisbuhler study. The GDP concentration reported by Geisbuhler et al. was similar to that seen in whole hearts and was equivalent to 90 nmole/g wet weight.

The pathways of purine nucleotide metabolism in heart are shown in figure 1.1. The metabolism of cGMP is discussed in section 1.4.2.

There are three pathways of guanine nucleotide synthesis:-

- (i) *De novo* synthesis from purine precursors.
- (ii) Synthesis from the existing adenine nucleotide pool or by salvage of adenine nucleotide breakdown products.
- (iii) Salvage from the guanine nucleotide breakdown products guanosine or guanine.

All result in the initial production of GMP, which is then sequentially converted to GDP and GTP by transphosphorylation reactions. Little work has been done to examine the relative contributions of these pathways to guanine nucleotide metabolism under various conditions. However, work on adenine nucleotides has shown that, in isolated rat hearts, *de novo* synthesis is about 0.02 nmole/min/g (Zimmer et al., 1973), while rates of salvage from nucleoside or free base are about 10-fold higher (Namm, 1973). This suggests that the salvage pathway is



more important for the short-term maintenance of purine nucleotide content, although *de novo* synthesis is necessary for the long-term recovery that occurs during the hours following periods of ischaemia or hypoxia (Swain et al., 1982b). Salvage involves a purine nucleoside cycle (nucleotide → nucleoside → base → nucleotide). Endothelial cells appear to play an important role in this, despite accounting for only 2-4% of the mass of the heart (Manfredi and Holmes, 1985).

### 1.3.1 *De novo* synthesis of guanine nucleotides

Adenine and guanine nucleotides share a common pathway of *de novo* synthesis as far as IMP. The regulatory step in IMP synthesis is the transfer of an amino group to 5-phosphoribose 1-pyrophosphate, catalysed by the enzyme amidophosphoribosyl transferase (EC 2.4.2.14). This enzyme contains two allosteric binding sites, one each for adenine and guanine nucleotides. Binding of nucleotide results in inhibition of the enzyme and is a feedback mechanism for controlling purine biosynthesis (Wyngaarden and Ashton, 1959).

The pathway from IMP to GMP is regulated by IMP dehydrogenase (EC 1.2.1.14) (IMP-DH), which is located in the cytosol and catalyses the NAD<sup>+</sup>-dependent conversion of IMP to XMP. The enzyme partially purified from human

placenta shows Michaelis-Menten kinetics and Michaelis constants for IMP and NAD<sup>+</sup> of 14 and 46  $\mu\text{M}$  respectively (Holmes et al., 1974). It is inhibited by XMP, GMP and AMP in a manner competitive with respect to IMP, with  $K_i$  values of 30  $\mu\text{M}$ , 100  $\mu\text{M}$  and 530  $\mu\text{M}$  respectively (Holmes et al., 1974). Inhibitors of IMP-DH have been developed as anti-cancer or anti-viral agents.

The final enzyme in the synthesis of GMP is GMP synthetase, which uses the free energy of pyrophosphate cleavage of ATP to drive the amination of XMP, using glutamine as amino group donor. It's activity may therefore be regulated by the phosphorylation potential of the cell. In an analogous manner, the enzyme adenylosuccinate synthetase, on the pathway from IMP to AMP, is dependent on GTP as co-factor ( $K_m = 18 \mu\text{M}$ ) (Maguire et al., 1972), suggesting reciprocal regulation of ATP and GTP synthesis.

Rates of *de novo* synthesis of adenine nucleotides are about 0.14 nmole/min/g in situ and 0.02 nmole/min/g in isolated perfused rat hearts (Zimmer et al., 1973). These rates increased by about 2-fold and 7-fold respectively during the first hour of recovery from asphyxia or ischaemia (Zimmer et al., 1973), presumably due to the release of negative feedback inhibition of amidophosphoribosyl transferase. There has been little work on the *de novo* synthesis of guanine nucleotides in heart. The amount of recovery of GTP during the 24 hours following ischaemia in

the endocardium of *in vivo* dog hearts, if all due to *de novo* synthesis, represents a rate of about 0.03 nmole/min/g, which increases to 0.06 nmole/min/g in the presence of the purine precursor 5-aminoimidazole-4-carboxamide riboside (Swain et al., 1982b). This is a lower limit, assuming negligible loss of purines from the cells during the 24 hour recovery period. The corresponding figures for ATP were 0.5 and 1.25 nmole/min/g.

### **1.3.2 Synthesis of guanine nucleotides from adenine nucleotides and by salvage pathways**

The other two pathways of guanine nucleotide synthesis, from adenine nucleotides or by salvage of breakdown products, are discussed together as some of the enzymes involved are common to both (see figure 1.1).

The salvage of guanine nucleotides from guanosine and guanine follow pathways analogous to those of inosine and hypoxanthine salvage (figure 1.1). Guanosine kinase is probably absent in heart (Geisbuhler and Rovetto, 1991), so guanosine appears to be converted initially to guanine by purine nucleoside phosphorylase (PNP), the guanine then being converted to GMP by hypoxanthine/guanine phosphoribosyltransferase (HGPRT). This has been demonstrated in isolated rat myocytes (Geisbuhler et al., 1987; Geisbuhler and Rovetto, 1991), whereby incubation in

the presence of labelled guanosine resulted in incorporation of label into the guanine nucleotide pool. This incorporation was stimulated by D-ribose (Geisbuhler and Rovetto, 1991), suggesting that the supply of phosphoribosylpyrophosphate for the HGPRT reaction was the rate-limiting factor, as appears to be the case for hypoxanthine salvage (Harmsen et al., 1984; Brown et al., 1985) (see below).

Synthesis of guanine nucleotides from the existing adenine nucleotide pool or adenine nucleotide breakdown products involves initial conversion to IMP, from where the pathway is common with that of *de novo* synthesis. This has been investigated in both perfused hearts and isolated myocytes.

Incorporation of label into guanine nucleotides occurred in isolated rabbit hearts following perfusion for up to 30 minutes in the presence of [<sup>14</sup>C]inosine (Tsuboi and Buckley, 1965), and in isolated rat hearts perfused with [<sup>14</sup>C]adenosine for up to one hour (Hutchinson et al., 1981). Similarly, rat hearts perfused with 0.02 mM [8-<sup>14</sup>C]hypoxanthine or [<sup>14</sup>C]inosine showed incorporation of label into both ATP and GTP (Harmsen et al., 1984). The rate of incorporation of hypoxanthine into GTP under normoxic conditions was 0.02 nmole/min/g, increasing to 0.05 nmole/min/g in the presence of D-ribose. Following a period of mild ischaemia (70% coronary flow reduction for 20 minutes), incorporation into GTP increased to 0.06 and

0.08 nmole/min/g in the absence and presence of D-ribose respectively (Harmsen et al., 1984). This suggests that the supply of PRPP for the HGPRT reaction is the rate-limiting step in the salvage pathway. The rates of incorporation into GTP were about 25% of the corresponding rates for ATP. Heart GTP content is only about 5% of ATP content (Harmsen et al., 1984), suggesting a relatively faster post-ischaemic recovery of GTP.

Isolated rat myocytes incubated in the presence of 1mM ribose incorporate [<sup>3</sup>H]hypoxanthine into GTP at rates of 0.004 nmole/min/10<sup>6</sup> cells (Brown et al., 1985), or 0.01 nmole/min/10<sup>6</sup> cells (Dow et al., 1987). In contrast, no incorporation into guanine nucleotides was seen following one hour of incubation with [<sup>3</sup>H]adenine (Brown et al., 1985), or following 6 minutes with [<sup>3</sup>H]adenosine (Dow et al., 1987), although low incorporation was reported by Altschuld et al., (1987) after a two hour incubation with [<sup>14</sup>C]adenosine.

The incorporation of adenosine into GTP in perfused hearts but not in isolated myocytes may be due to the compartmentation of purine metabolism between different cell types. Adenosine incorporation into GTP requires initial conversion to IMP, which in theory can occur by three possible routes; via AMP, via inosine, or via inosine and hypoxanthine (fig.1.1). Although adenosine kinase is present in heart (Namm, 1973), AMP-deaminase activity

appears to be low, as shown by the insignificant accumulation of IMP in rat hearts under both normal and ischaemic conditions (Geisbuhler et al., 1984). No inosine kinase activity can be detected in heart (De Jong and Kalkman, 1973). Therefore, the major pathway for adenosine incorporation into GTP would appear to be adenosine → inosine → hypoxanthine → IMP (see figure 1.1). In myocytes some adenosine deaminase activity is present (Nees and Gerlach, 1983), so the finding that hypoxanthine is incorporated into GTP in isolated myocytes, while adenosine is not, suggests that purine nucleoside phosphorylase (PNP) activity is low or absent in myocytes. On the other hand PNP is present in whole heart, and has a  $K_m$  for guanosine of 10-58  $\mu\text{M}$  (Murray et al., 1970). However, the evidence regarding its location is not conclusive. Several earlier studies did suggest that PNP was absent in myocytes but present in endothelial cells and other cells of the vessel wall (Borgers et al., 1972; Rubio et al., 1972; Rubio and Berne, 1980). Also, when isolated rabbit hearts were perfused with labelled guanosine, large quantities of labelled guanine appeared in the effluent, but there was no significant accumulation of labelled guanine in the heart (Tsuboi and Buckley, 1965). This again could suggest that PNP is localised to the endothelial cells. Later, Bowditch et al., (1985) estimated that only 5% of PNP activity was associated with myocytes. However, more recently De Jong et al., (1990) reported PNP activity in isolated adult rat myocytes which did not differ significantly from that found

in whole hearts, suggesting that almost all of the PNP activity was associated with myocytes in the rat. In support of this it has been reported that incubation of isolated rat myocytes in the presence of [<sup>3</sup>H]-guanosine for up to 90 minutes resulted in incorporation of label into the guanine nucleotide pool (Geisbuhler et al., 1987; Geisbuhler and Rovetto, 1991). This was stimulated by D-ribose, suggesting that guanosine salvage involved the pathway guanosine → guanine → GMP. It is however, conceivable that their precursor contained some labelled guanine in addition to the nucleoside. The alternative pathway of guanosine salvage, involving direct phosphorylation of guanosine by a nucleoside kinase, cannot be discounted, although this has not been unequivocally demonstrated in heart; any such activity probably reflecting the combined activities of PNP and HGPRT (Anderson, 1973). However, if PNP activity is located mainly in endothelial cells, this would account for the much greater incorporation of adenosine into guanine nucleotides in whole hearts than in isolated myocytes.

HGPRT is the enzyme responsible for salvage of both guanine and hypoxanthine. It has about equal affinity for both bases, which compete for the active site (Krenitsky et al., 1969; Krenitsky and Papaioannou, 1969). The equilibrium for HGPRT heavily favours the formation of nucleotide (Krenitsky et al., 1969), the  $K_m$  for guanine being 3-11  $\mu M$  (Murray et al., 1970). HGPRT appears to be the rate-

limiting step in both hypoxanthine and guanine salvage as the rate of salvage is increased in the presence of D-ribose (Brown et al., 1985; Geisbuhler and Rovetto, 1991). HGPRT activity has been demonstrated in both myocytes and endothelial cells, with activity in the latter being three-fold greater (Nees et al., 1980). This is similar to the situation for adenine phosphoribosyltransferase (Nees et al., 1980), and suggests that endothelial cells play an important role in purine salvage. Also relevant is the finding of a three-fold greater adenine nucleotide concentration in endothelial cells in guinea-pig hearts compared to myocardium as a whole (Nees and Gerlach, 1983). Such unequal distributions of nucleotides and enzyme activity may result in a disproportionate labelling of the endothelial cells following perfusion with radioactive purine nucleosides or bases.

The uptake by isolated myocytes of [<sup>3</sup>H]-guanosine, [<sup>3</sup>H]-adenosine and [<sup>3</sup>H]-inosine are mutually competitive, suggesting transport by a common carrier (Geisbuhler et al., 1987).

### **1.3.3 GTP synthesis and control of guanine nucleotide ratio**

The conversion of GMP to GTP is a two-step process catalysed by the enzymes nucleoside monophosphate kinase



(GMP + ATP = GDP + ADP) and nucleoside diphosphate kinase (GDP + ATP = GTP + ADP), the latter also being important in the control of the GTP/GDP ratio. Synthesis of GTP is also catalysed by guanosine triphosphate monophosphate kinase (2GDP = GMP + GTP), and guanylate kinase (GDP + ADP = GTP + AMP).

#### **1.3.3.1 Nucleoside monophosphate kinase (EC 2.7.4.8)**

Nucleoside monophosphate kinase catalyses the phosphorylation of GMP to GDP. It is ubiquitous and has been purified and characterised from a number of tissues including rat liver (Buccino and Roth, 1969), human erythrocytes (Miller and Miller, 1980), and bovine retina (Hall and Kuhn, 1986), although the enzyme from heart appears not to have been studied in any detail. Nucleoside monophosphate kinase from both rat liver and bovine retina are 20 kd proteins with a requirement for  $Mg^{2+}$  and specificity for GMP over other nucleoside monophosphates (Buccino and Roth, 1969; Hall and Kuhn, 1986). The enzyme from bovine retina has a  $K_m$  value for GMP of 13  $\mu M$  and for ATP of 430  $\mu M$  (Hall and Kuhn, 1986).

#### **1.3.3.2 Nucleoside diphosphate kinase (EC 2.7.4.6)**

Nucleoside diphosphate kinase (NDP kinase) catalyses the transfer of a phosphate group between ATP and other nucleoside diphosphates (NDP), by a ping-pong mechanism

involving a phosphorylated enzyme intermediate (Mourad and Parks, 1965). The enzyme is ubiquitous and occurs as a number of isozymes (80 - 110 kd), each having different specificities for the various nucleotide tri- and diphosphates. Approximately 80% of the NDP kinase activity of rat heart is cytoplasmic while a minimum of 2.5% is mitochondrial (Jacobus and Evans, 1977), a distribution similar to the beef heart enzyme (Colomb et al., 1969; 1972). The enzyme from beef heart mitochondria has Km value for ATP and ADP of 1.4 and 0.1 mM respectively (Parks and Agarwal, 1973), and appears to prefer free ADP as substrate (Colomb et al., 1969). In contrast, the cytosolic enzyme requires that the substrates ATP and ADP be complexed with  $Mg^{2+}$  (Colomb et al., 1972). Phosphate binding studies suggest that NDP kinase exists in multimeric forms (Parks and Agarwal, 1973). The activity of NDP kinase in most tissues is about 10-100 times greater than that of nucleoside monophosphate kinase (Parks and Agarwal, 1973), and it is thought that under normal conditions the NDP kinase reaction is at or close to equilibrium, ensuring maintenance of a high GTP/GDP ratio. However, there is evidence that NDP kinase can act as a regulatory enzyme and that the reaction may depart from equilibrium under certain conditions. NDP kinase shows conformational changes often associated with regulatory enzymes (Agarwal and Parks, 1971; Goffeau et al., 1967). Purified cytoplasmic NDP kinase from beef heart is strongly inhibited by the substrate MgADP ( $K_i = 20 \mu M$ ,  $K_m = 100 \mu M$ ; Colomb et al.,

1974), which accumulates in the initial stages of ischaemia. The free MgADP concentration in Langendorff perfused rat hearts is estimated as 20  $\mu\text{M}$  under aerobic conditions, rising to about 60  $\mu\text{M}$  during anoxia (Kohn et al., 1977). Therefore during anoxia inhibition of NDP kinase by MgADP may prevent further ATP breakdown by this enzyme. Also, Thompson and Atkinson, (1971) showed that NDP kinase activity from bovine liver decreased with a decrease in the energy charge. Furthermore, cells containing high NDP kinase activity have not always shown a high correlation between the various triphosphate/diphosphate ratios (Brown et al., 1972), and a poor correlation between the ATP/ADP and GTP/GDP ratios has been observed in perfused hearts (Mowbray et al., 1984), although intracellular compartmentation of purine nucleotides could be one explanation of the poor correlation.

Inhibition of nucleoside diphosphate kinase following stress would serve two purposes. Firstly, it would reduce ATP use in transphosphorylation reactions, and secondly, it would allow the GTP/GDP ratio to fall, which may help conserve energy by inhibiting GTP-dependent processes.

There is evidence that nucleoside diphosphate kinase is closely associated with various GTP-binding proteins in cell membranes, and may control the activity of these proteins by regulating the local concentration of GTP or the GTP/GDP ratio. Thus NDP kinase activity has been found

associated with elongation factor (Walton and Gill, 1975), microtubules (Nickerson and Wells, 1984), ras-like p21 GTP-binding protein (Ohtsuki et al., 1986) and the alpha-subunit of Gs (Kimura and Shimada, 1988a, 1988b). The possible role of NDP kinase in regulation of G-protein activity is discussed in section 1.4.1.3.

#### 1.3.4 Guanine nucleotide breakdown

Guanine nucleotide breakdown involves successive dephosphorylation reactions to form guanosine. The breakdown of GTP to GDP and GMP occurs by the numerous GTPase reactions in cells, and also by the nucleoside mono- and diphosphate kinase reactions, which may run in reverse when the ATP/ADP ratio falls. Breakdown of GMP to guanosine is catalysed by 5'-nucleotidase (EC 3.1.3.5), which occurs as soluble and membrane-bound forms. The soluble form from homogenates of guinea-pig heart shows activities with GMP that are about 50% greater than with IMP but only 78% of the activity observed with AMP (Schutz et al., 1981). The membrane-bound form of the enzyme from rat myocardium has about equal capacities for metabolism of GMP and IMP, which are about half that for AMP (Naito and Lowenstein, 1981). The enzyme from rat heart sarcolemma appears to have catalytic sites at both the intra- and extracellular surface (Lamers et al., 1983).

Guanosine can be broken down by PNP to form guanine, which can then be metabolised sequentially to xanthine and uric acid by the enzymes guanine deaminase and xanthine oxidase respectively (Manfredi and Holmes, 1985).

There is no evidence of a myocardial GMP reductase, which would convert GMP to IMP, as shown by the absence of label in IMP or adenine nucleotides following perfusion of isolated rat hearts with [<sup>14</sup>C]-guanosine (Tsuboi and Buckley, 1965), or incubation of isolated rat myocytes with [<sup>3</sup>H]-guanosine (Geisbuhler and Rovetto, 1991).

#### **1.3.5 Effect of ischaemia on guanine nucleotides**

As for adenine nucleotides, depletion of guanine nucleotides has been demonstrated during ischaemia or hypoxia in both whole hearts and isolated myocytes. Decreases in cardiac GTP concentration occurred following the onset of ischaemia in isolated perfused rat hearts (Deuticke et al., 1966). In open-chested dogs, 12 minutes of ischaemia resulted in a fall in GTP and an increase in guanosine content, these changes being partially reversed following 60 minutes of reperfusion (Swain et al., 1982a). In isolated rat myocytes, 45 minutes of anoxia resulted in a fall in GTP content to undetectable levels, while reoxygenation for 15 minutes resulted in partial recovery (Altschuld et al., 1987). Such depletion of GTP during

ischaemia or hypoxia is usually attributed to a fall in the cellular phosphorylation potential, which inhibits resynthesis of GTP from its breakdown products (Thompson and Atkinson, 1971).

Early work on rat hearts showed that adenine and guanine nucleotides decreased in parallel during ischaemia, both ATP and GTP content falling to about 10% of control values after 20 minutes (Deuticke et al., 1966). In open-chested dogs 12 minutes of ischaemia resulted in parallel decreases in the ATP and GTP contents (to 57% and 65% of controls respectively), and after 60 minutes of reperfusion both showed a similar extent of partial recovery (Swain et al., 1982a). Further work on open-chested dogs showed parallel recovery of ATP and GTP after 24 hours of reperfusion, the recovery being partial in control hearts and complete in those treated with the purine precursor 5-aminoimidazole-4-carboxamide riboside (Swain et al., 1982b). GDP content was not measured, so nucleotide ratios could not be compared.

In contrast, other work suggests that adenine and guanine nucleotide content and ratios can be regulated independently under certain conditions. Work in this laboratory on isolated perfused rat hearts has consistently shown post-ischaemic synchronous fluctuations in purine nucleotide content (Bates et al., 1978; Mowbray et al., 1981; 1984). The correlation between the ATP/ADP and GTP/GDP ratios was high in one study (Bates et al., 1978),

but low in another (Mowbray et al., 1984), while another study showed a poor correlation between the total adenine and guanine nucleotide contents (Mowbray et al., 1981). Post-ischaemic reperfusion of rat hearts with [<sup>14</sup>C]-hypoxanthine or inosine showed an incorporation rate into GTP of about 25% of that for ATP (Harmsen et al., 1984). As the GTP content in heart is only about 5% of the ATP content, this indicates a faster recovery of GTP after ischaemia. Also, isolated rat myocytes incubated anaerobically for 45 minutes, followed by 15 minutes of reoxygenation, showed a greater recovery of mean GTP content compared with ATP content (to 57% and 33% of control values respectively) (Altschuld et al., 1987).

Despite considerable differences between these experiments regarding conditions and species, the observations that adenine and guanine nucleotides do not always change in parallel suggest that a mechanism for their independent regulation exists.

#### **1.4 Role of guanine nucleotides in heart**

Apart from being a constituent of DNA and RNA, guanine nucleotides are obligatory for many cellular processes. The free energy of hydrolysis of GTP drives the synthesis of DNA, RNA and protein, membrane fusion and acts as the switch in signal transmission. Guanine nucleotides also act

as enzyme co-factors, while cGMP is a second messenger for certain hormones and neurotransmitters.

Many GTP-dependent processes use the free energy of GTP hydrolysis to drive the cycling of a GTP-binding protein between active (GTP-bound) and inactive (GDP-bound) conformational forms, thus constituting a molecular switch (fig 1.2a). Such GTP-binding proteins include G-proteins which mediate signal transmission, various translational factors and proteins mediating membrane fusion and cell proliferation (see Bourne et al., 1990; Boguski and McCormick, 1993).

Those processes likely to be important in the metabolism of the post-ischaemic heart are described below.

#### **1.4.1 G-proteins and signal transmission**

Changes in cardiac output brought about by muscarinic or  $\alpha$ - or  $\beta$ -adrenergic agonists are mediated by G-proteins.

##### **1.4.1.1 Structure and function of G-proteins**

The G-proteins involved in plasma membrane fast signal transmission are a family of heterotrimeric proteins associated with the plasma membrane, which mediate the effect of the agonist-receptor complex on the effector



protein in a GTP-dependent manner (see Gilman, 1987; Neer and Clapham, 1988). More than a dozen have been identified to date, each consisting of an alpha, beta and gamma subunit in decreasing order of size, the alpha subunit containing a guanine nucleotide binding site (Gilman, 1987). The free energy of GTP hydrolysis is used to drive the cycling of the G-protein between the inactive GDP-bound and the active GTP-bound forms. The rate-limiting step appears to be the dissociation of GDP from the inactive form: this is accelerated by interaction with the agonist/receptor complex, which opens a pocket containing the guanine nucleotide binding site, allowing  $Mg^{2+}$ -dependent exchange of GDP for GTP and activation of the G-protein (Cassel and Selinger, 1977). Deactivation is brought about by the intrinsic GTPase of the  $\alpha$ -subunit, which is promoted by the effector protein, at least in the case of  $G_o$  and  $G_t$  (Bourne and Stryer, 1992). The active form of the G-protein modifies the activity of the effector protein, which may be an enzyme or ion channel. Activation of the G-protein may involve dissociation into  $\alpha$ - and  $\beta\gamma$ -subunits, the  $\alpha$ -subunit being the active part in most cases (Gilman, 1987), although the arguments against dissociation are substantial (Levitzki, 1988).

The pathways by which G-proteins mediate the effects of adrenergic and muscarinic agonists on cardiac output are shown in figure 1.2b, while table 1.4 lists the G-proteins so far identified in heart and their functions (for review

see Robishaw and Foster, 1989).

**Table 1.4**      *G-proteins found in heart*

| G-protein   | Function                                      | Reference                         |
|-------------|---|-----------------------------------|
| Gs          | Stimulation of<br>adenylate cyclase           | Northup et al., (1983)            |
|             | Opening of L-type<br>calcium channels         | Imoto et al., (1988)              |
| Gi          | Inhibition of<br>adenylate cyclase            | Katada et al., (1984)             |
| Gi or<br>Gk | Opening of atrial<br>K <sup>+</sup> -channels | Yatini et al., (1988)             |
| Gp          | Stimulation of<br>phospholipase C             | Cockcroft and Gomperts,<br>(1985) |

**Figure 1.2** *G-proteins and control of cardiac output*

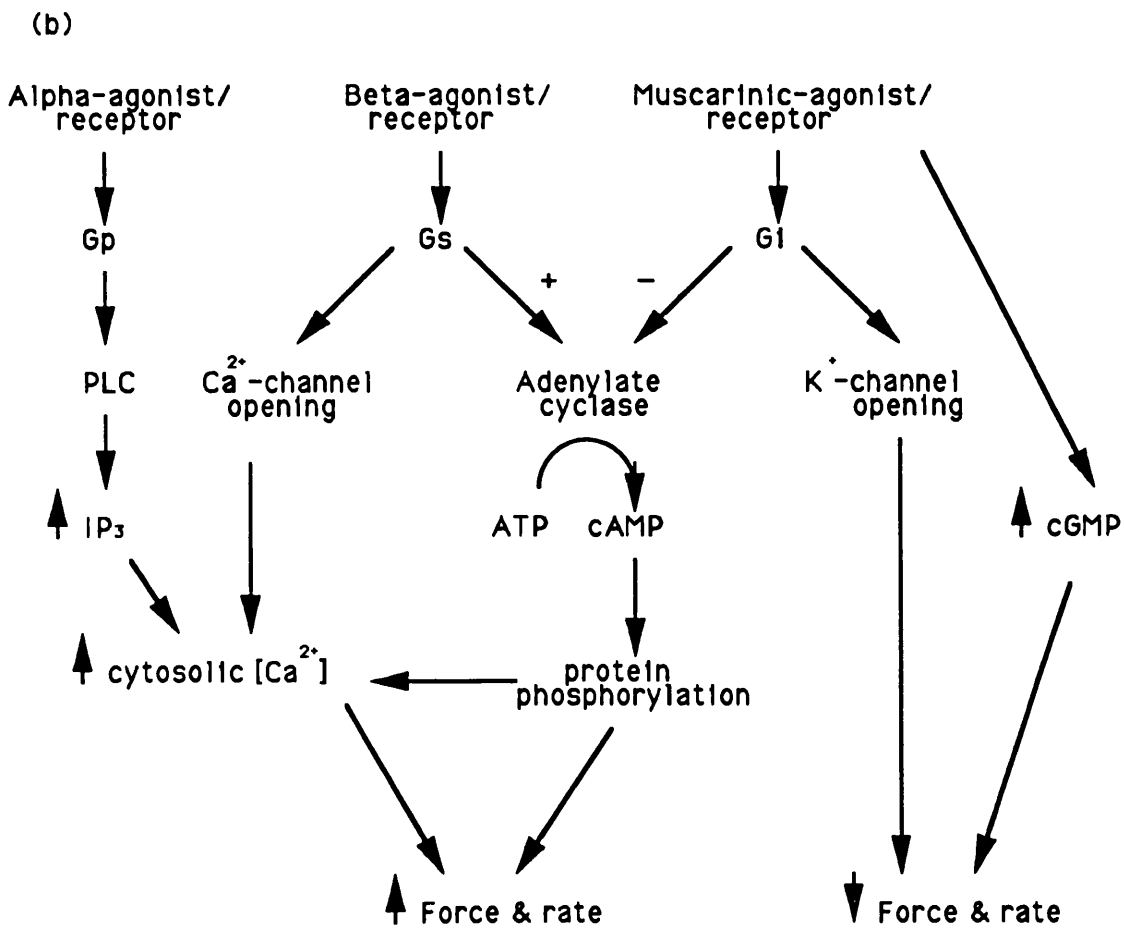
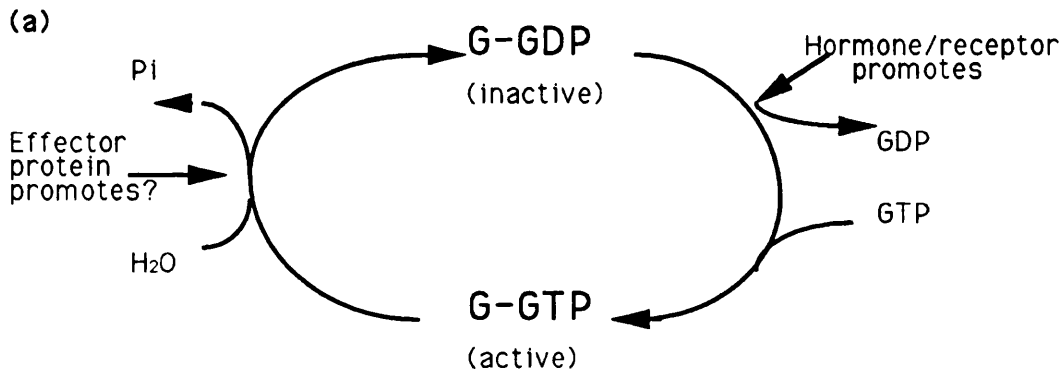

#### 1.4.1.2 Guanine nucleotides and G-protein activity

The effect of GTP concentrations on G-protein activity has been studied in both isolated cells and cell-free systems, and differences in results between the two approaches have shed light on possible compartmentation of guanine nucleotide metabolism.

Although no work appears to have been done on heart cells, work on other cell types has shown that guanine nucleotide depletion, using IMP-dehydrogenase inhibitors, reduces the G-protein response to agonists (Rizzo et al., 1990). In intact Ehrlich ascites tumour cells, reduction of GTP concentrations to 22% of normal (from 1.22 to 0.27 nmoles/10<sup>6</sup> cells), by incubating with mycophenolic acid, resulted in the cAMP concentration after addition of adrenaline being half that of control cells, the basal level of cAMP being unaffected (Smith et al., 1977). In cultured C6 glioma cells depletion of GTP using mycophenolic acid resulted in reduction of the cAMP response to the  $\beta$ -agonist isoprenaline (Franklin and Twose, 1977). This effect was reversed by incubating the cells in the presence of guanine, suggesting that reduced GTP content was the cause, rather than a direct effect of the mycophenolic acid on adenylate cyclase. The adenylate cyclase response to isoprenaline of whole homogenates from C6 cells treated with mycophenolic acid was also reduced, and was restored to normal by the addition of GTP (Franklin and Twose, 1977). Rat kidney cells treated with

mycophenolic acid or ribavirin resulted in reduction of GTP content to 20% of normal, and decreased the ability of prostaglandin E1 or isoprenaline to elevate cAMP levels (four-fold increase in cAMP compared to ten-fold for controls) (Johnson and Mukku, 1979). Basal cAMP levels were unaffected. Addition of guanosine with the inhibitor restored both normal GTP concentrations and the response to prostaglandin E1 and isoprenaline. The response to isoprenaline was also restored within five minutes of removing mycophenolic acid (Johnson and Mukku, 1979), suggesting a rapid synthesis of guanine nucleotides in these cells.

In all of these studies the concentration of GTP remaining after guanine nucleotide depletion was still far higher than the apparent  $K_m$  for the steady-state GTPase activity of G-proteins, which is about  $0.3 \mu M$  when measured in reconstituted membrane vesicles (Brandt and Ross, 1985). A possible reason for this is that reconstitution into membrane vesicles alters the kinetic parameters of the G-protein. Also, compartmentation may mean that measurements of whole cell GTP concentrations do not reflect the concentrations of GTP available to the G-protein (see below).

The kinetics of the effects of GTP and GDP on G-protein activity have been studied extensively in cell-free systems, mostly using reconstituted membrane vesicles (see

Gilman, 1987). There is negative co-operativity of binding of agonist/receptor complex and guanine nucleotide to the G-protein oligomer, the agonist/receptor complex thereby increasing GDP/GTP exchange, supposedly by opening a pocket containing the nucleotide binding site (Gilman, 1987). GTP $\gamma$ S promotes dissociation of the G-protein while GDP inhibits it, and low (nM) levels of Mg<sup>2+</sup> stabilise the G $\alpha$ /GTP $\gamma$ S complex, shifting the equilibrium in favour of dissociation, while high (mM) levels decrease association of GDP with both G $\alpha\beta\gamma$  and G $\alpha$  (Higashijima et al., 1987b). Normal cardiac cytosolic free Mg<sup>2+</sup> concentrations are about 0.5-1.0 mM (Murphy et al., 1991), and it has been suggested that the agonist/receptor complex modulates Gs activity by reducing its Mg<sup>2+</sup> requirement to about this level (Iyengar and Birnbaumer, 1982). The steady state GTPase activity has a K<sub>m</sub> for MgGTP of 0.3  $\mu$ M (Brandt and Ross, 1985). GDP dissociation appears to be the rate-limiting step (Cassel and Selinger, 1977; Higashijima et al., 1987a), with the consequence that during steady-state conditions a majority of the protein exists as the GDP-bound form (Brandt and Ross, 1985). The affinity of GDP for G-proteins is high, ranging from about 0.1 nM in the absence of Mg<sup>2+</sup> to about 10 nM in the presence of 10 mM Mg<sup>2+</sup> (Gilman, 1987).

Given that there is only one guanine nucleotide binding site situated on the  $\alpha$ -subunit, GDP dissociation must occur before GTP can bind, so in the presence of bound GDP, the rate of GTP binding will be independent of GTP

concentration. Although this suggests that GTP concentrations are not important, the agonist/receptor complex stimulates GTPase activity by increasing the rate of dissociation of GDP, allowing replacement by GTP, and under these conditions the GTP concentration may become rate-limiting. *In vitro* studies have shown a  $K_m$  for GTP of  $0.3 \mu\text{M}$  for steady-state GTPase activity (Brandt and Ross, 1985), which is much lower than normal cardiac cytoplasmic GTP concentration of  $300 \mu\text{M}$  (Bates et al., 1978). This suggests that the GTP content is unlikely to become rate-limiting, but this may not reflect the situation *in vivo* (see below). Another important factor may be the GTP/GDP ratio, as GDP has been found to inhibit binding of [ $\alpha$ - $^{32}\text{P}$ ]GTP ( $K_i = 0.24\text{--}0.65 \mu\text{M}$ ) and the steady-state GTPase ( $K_i = 0.5 \mu\text{M}$ ) (Brandt and Ross, 1985), presumably by competing with GTP for the guanine nucleotide binding site on the  $\alpha$ -subunit.

These *in vitro* studies may not accurately reflect the situation occurring *in vivo* for several reasons. Firstly, many of the studies were done using reconstituted membrane vesicles, the membrane composition and architecture of which may be different from that occurring *in vivo*. It is known that membrane bound enzymes are very sensitive to changes in membrane characteristics and detergent and ionic constituents in suspending media (Lefkowitz et al., 1983). Secondly, reconstituted vesicles obtained from whole organs such as heart will be derived from more than one cell type

eg myocyte, vascular smooth muscle, endothelial cell etc., and will therefore result in the loss of information regarding intercellular compartmentation. Thirdly, compartmentation of guanine nucleotides within the cell means that the measured whole cell concentrations may not be typical of the concentrations in the vicinity of the G-proteins. Relevant to this is the finding that putative G-protein-mediated inhibition of  $Ca^{2+}$  channels has been observed in cells infused with nucleotide-free solutions (Marchetti et al., 1986; Tsunoo et al., 1986); one explanation being that intracellular compartmentation ensures that a sufficiently high concentration of GTP is maintained in the vicinity of the G-protein. Also relevant is the finding that NDP kinase appears to be associated with G-proteins in the membrane, and may control G-protein activity by regulating the local concentration of GTP (Kimura and Shimada, 1988a, 1988b) (see section 1.4.1.3.). Finally, much of the GTP may be bound so that the concentration of free GTP is much lower than whole cell measurements would suggest. Using the patch clamp technique, measurement of GTP activity in intact isolated frog atrial cells suggests that the concentration of GTP in the pool accessible to G<sub>k</sub>, the G-protein that couples muscarinic receptors to  $K^+$ -channels, is 25-50  $\mu M$  (Breitweise and Szabo, 1988) This is about 10-fold lower than whole tissue measurements. Also, the activity of acetylcholine-activated  $K^+$ -channel in inside-out patches of atrial membranes suggest a free GTP concentration of about 100  $\mu M$



(Horie and Irisawa, 1989). Furthermore, the half-saturation concentration of GTP for agonist activation of Gk was about 25  $\mu\text{M}$  (Horie and Irisawa, 1989). Therefore, under physiological conditions, the agonist-activated Gk is not fully saturated with GTP, suggesting the GTP content can act as a regulator of Gk activity.

#### 1.4.1.3 Nucleoside diphosphate kinase and G-protein activity

There is increasing evidence that nucleoside diphosphate kinase (NDP kinase) is closely associated with various GTP-binding proteins in cell membranes, and may control the activity of these proteins by regulating the local concentration of GTP or the GTP/GDP ratio (Otero, 1990).

Many studies, apparently successful at demonstrating G-protein-mediated effects using patch pipettes, have used solutions containing ATP but no GTP (Schultz et al. 1990). Also, ATP $\gamma$ S is capable of activating muscarinic K<sup>+</sup>-channels in atrial cells (Otero et al., 1988). The presence of membrane associated NDP kinase could ensure a continuous supply of GTP to the G-protein by the phosphorylation of endogenous GDP. Evidence for this is that membrane associated NDP kinase and Gs appeared to be extractable as a complex from rat liver cell membranes, and this complex formation appeared to be inhibited by GDP and somewhat enhanced by GppNHp, the effects being modified by agonist

(Kimura and Shimada, 1988a, 1988b). This led to the suggestion of a close functional association between NDP kinase and G-proteins, and that the kinase acts as a regulator of adenylate cyclase by controlling the local concentration of GTP and the GTP/GDP ratio. Such regulation would be effective only if the equilibration between the local guanine nucleotide content and that of the bulk cellular fluid was very slow. The demonstration of putative G-protein activity in the presence of nucleotide free solutions in the patch pipettes (Marchetti et al., 1986; Tsunoo et al., 1986) would seem to support this. If such a regulatory system operated in the heart, it would help to conserve ATP during times of stress (ie. low ATP) by inhibiting the positive inotropic and chronotropic effects of  $\beta$ -agonists.

#### **1.4.1.4 G-proteins and cardiac ischaemia**

Studies in other cell types have shown that depletion of guanine nucleotides results in inhibition of G-protein-mediated adenylate cyclase activity (Rizzo et al., 1990). However, there does not appear to be any evidence that changes in G-protein-mediated events following cardiac ischaemia could be due to guanine nucleotide depletion. Workers examining the effects of ischaemia on signal transmission have not measured cellular guanine nucleotide content. There is also the possibility that ischaemia-

induced changes at the level of the receptor, G-protein subunits, effector enzyme, or in ATP concentration will affect signal transmission.

Work has focused on the  $\beta$ -receptor/adenylate cyclase system, as increased cAMP concentrations have been implicated in the pathogenesis of post-ischaemic arrhythmias (Corr et al., 1978). Increases in cAMP concentrations were found in cat hearts after 5 minutes of ischaemia (Corr et al. 1978), and in dog hearts 5 seconds after the onset of global ischaemia, which was followed by a slow decline (Wollenberger et al., 1969). These early rises in cAMP are thought to be due to ischaemia-induced release of endogenous catecholamines, as they are sensitive to  $\beta$ -blockade in both dog (Wollenberger et al., 1969) and rat hearts (Dobson and Mayer, 1973). Longer periods of ischaemia (15 minutes) in isolated rat hearts resulted in abolition of the isoprenaline-induced increase in cAMP and decreases in the response to isoprenaline of the contractile force and phosphorylase activation (Krause and England, 1982). GTP concentrations were not measured, so whether the apparent reduced activity of adenylate cyclase was due to lack of GTP or some other factor(s) was not clear. Other studies on isolated perfused rat hearts have shown ischaemia-induced systematic fluctuations in both cAMP and cGMP concentrations for up to 80 minutes after short periods of ischaemia (Bates et al., 1978; Mowbray et al., 1981; 1984), although it has not been shown that these

are due to changes in GTP content. One study did show a positive correlation between GTP and cAMP concentrations (Bates et al., 1978), but it was not clear whether this was cause and effect or whether both substances were responding to a common controlling mechanism.

Certainly, factors other than the GTP concentration do affect the post-ischaemic response to agonists. Thus in conscious dogs, one hour of myocardial ischaemia resulted in an increase in the number of  $\beta$ -adrenergic receptors but a decrease in the activity of adenylate cyclase (Vatner et al., 1988). *In vitro* assays of adenylate cyclase activity from ischaemic dog heart (in the presence of 20  $\mu$ M GTP) showed a progressive decline in both isoprenaline- and fluoride-stimulated activity following 20 and 60 minutes of ischaemia (Drummond and Sordahl, 1981). Using *in vivo* dog hearts it has been shown that the GTP-stimulated activity of Gs was reduced after one hour of ischaemia (Susanni et al., 1989), and that five minutes of ischaemia reduced the ability of both carbachol and GppNHp to inhibit forskolin-stimulated adenylate cyclase (Niroomand et al., 1992). This latter effect was not accompanied by a reduction in the content of total Gi (as determined by pertussis toxin catalysed ADP-ribosylation of sarcolemmal proteins), suggesting that a functional impairment of Gi was the cause. Therefore, determining the effects of post-ischaemic GTP depletion on signal transmission may be complicated by other effects which are independent of GTP concentration.

#### 1.4.2 cGMP as a second messenger

cGMP acts as a second messenger in many tissues (Tremblay et al., 1988). In heart it is thought to play a part in mediating the negative inotropic and chronotropic effects of muscarinic agonists, and may oppose the action of cAMP by stimulating its breakdown (Hartzell and Fischmeister, 1986). Post-ischaemic increases in cAMP have been associated with arrhythmias (Corr et al., 1978), so the ability of the heart to synthesise cGMP after ischaemia may be important for maintaining normal cardiac rhythm.

##### 1.4.2.1 Synthesis of cGMP

cGMP is synthesised from GTP by guanylate cyclase, of which there are two main types, particulate and soluble, both of them found in heart (Kimura and Murad, 1974). They have an absolute requirement for divalent cation ( $Mg^{2+}$ ,  $Mn^{2+}$ ), and show greater activity (at least five times) with GTP-Mn as substrate than with GTP-Mg (Chrisman et al., 1975). Both enzymes are inhibited by millimolar concentrations of ATP (Kimura and Murad, 1974).

Particulate guanylate cyclase, purified from several sources including bovine and rat lung, is a 150 kD transmembrane glycoprotein activated by hormones such as atrial natriuretic factor (ANF), and has a  $K_m$  for GTP-Mn of

100-150  $\mu\text{M}$  (Tremblay et al., 1988). Solubilisation with detergent increases its activity by about 5- to 10-fold and changes its behaviour from positive cooperative kinetics with respect to both  $\text{Mn}^{2+}$  and GTP to Michaelis-Menten kinetics (Tremblay et al., 1988). Extraction of a tightly coupled functional ANF receptor/guanylate cyclase system using detergents has suggested that the receptor and enzyme are the same molecule (Lowe et al., 1989).

Soluble guanylate cyclase has been purified as a 150 kD heterodimer from a number of tissues, including rat lung (Garbers, 1979) and bovine lung (Gerzer et al., 1981). It contains a haem moiety which is necessary for maximal activation, the loss of the haem resulting in reduced activation by nitric oxide (Gerzer et al., 1982). It displays Michaelis-Menten kinetics with an apparent  $K_m$  for GTP-Mg during basal activity of about 100  $\mu\text{M}$  which is shifted to 10-30  $\mu\text{M}$  in the presence of sodium nitroprusside or nitric oxide (Gerzer et al., 1981). The enzyme is activated by nitric oxide (NO) and by NO producing substances such as sodium nitroprusside, N-nitrosamines, nitrites etc. (Bohme et al., 1984); this probably being the mechanism by which endothelium-derived relaxing factor (EDRF) and nitrovasodilators exert their effect (Furchgott and Vanhoutte, 1989; Ignarro, 1990). The hormonal activation of soluble guanylate cyclase may also be mediated by arachidonic acid or its metabolites (Gerzer et al., 1986).

The relatively high  $K_m$  values for both the soluble and particulate enzymes suggest that intracellular GTP concentrations may play a part in the regulation of their activity. ATP may also be an important regulator of guanylate cyclase activity, both soluble and particulate types being inhibited by ATP at low concentrations (<1 mM) (Kimura and Murad, 1974). However, as heart ATP concentration is normally about 10mM, it would appear that compartmentation of ATP or some other factor such as the ATP/GTP ratio is involved in mitigating this inhibition. Steady-state perfused rat hearts showed inversely related oscillations between cGMP and total adenine nucleotide concentrations (Mowbray et al., 1981), which may be evidence of ATP inhibition of guanylate cyclase. A further study, also on rat hearts, showed inversely related oscillations between cGMP and ADP content after a brief period of ischaemia (Mowbray et al., 1984). It is not clear whether this was due to direct inhibition of guanylate cyclase by ADP, or to reduced availability of divalent cation.

#### 1.4.2.2 Degradation of cGMP

The breakdown of cGMP to GMP is catalysed by various phosphodiesterases, each with particular specificities for cGMP or cAMP. Heart contains three such enzymes, one each specific for cAMP and cGMP and the third able to hydrolyse

both (Terasaki and Appleman, 1975).

The cGMP specific enzyme is a 120 kD dimer, with a  $K_m$  for cGMP of 10  $\mu\text{M}$  (compared with 200  $\mu\text{M}$  for cAMP), and is stimulated by calcium-calmodulin (Beavo et al., 1982). The enzyme that hydrolyses both cyclic nucleotides is thought to be a cGMP-stimulated phosphodiesterase, having a  $K_m$  for cGMP of 10  $\mu\text{M}$  (compared with 30  $\mu\text{M}$  for cAMP), and contains an allosteric binding site for cGMP, the binding of which stimulates the enzyme (Martins et al., 1982). The enzyme purified from bovine heart shows strong positive homotropic cooperativity for both cAMP and cGMP hydrolysis, while binding of cGMP to the allosteric site results in loss of positive cooperativity and an increase in cAMP hydrolysis (Martins et al., 1982). This enzyme may explain the observation that cGMP opposes the effect of cAMP in heart (Hartzell and Fischmeister, 1986).

In the particular case of the vertebrate visual system, the activity of cGMP phosphodiesterase is regulated by the G-protein transducin (Gt) in response to light-activated rhodopsin (Fung et al., 1981). Whether the enzyme in other tissues is also regulated via G-proteins is not clear.

#### 1.4.2.3 Action of cGMP

Acetylcholine causes an approximately three-fold increase



in the concentration of cGMP in perfused rat hearts (George et al., 1970, 1973; Gardner and Allen, 1976); this increase being in parallel to its negative inotropic action (George et al., 1970, 1973), while 8-bromo-cGMP has a negative inotropic effect on rat atria and cat papillary muscle (Nawrath, 1976). These results suggest that cGMP is the second messenger of muscarinic stimulation, although two findings have complicated this. Carbachol has a negative inotropic effect at concentrations lower than those necessary to raise cGMP content (Brooker, 1977), while sodium nitroprusside raises cardiac cGMP content without having any inotropic effect (Diamond et al., 1977). However, the former effect may be due to carbachol acting via cGMP-independent pathways, such as G-protein-mediated inhibition of adenylate cyclase or opening of K<sup>+</sup>-channels, while the latter effect may be due to compartmentation of cGMP or its effector protein between different cell types. Further evidence of compartmentation came from the finding that, in rat hearts, a cGMP-dependent protein kinase was activated following acetylcholine-induced increases in cGMP, but not after increases in cGMP brought about by nitroprusside (Lincoln and Keely, 1981). The nitroprusside effect may be confined to the guanylate cyclase in smooth muscle cells involved in vasodilation.

It appears that cGMP can act via activation of a cGMP-dependent protein kinase, or by either stimulating or inhibiting the hydrolysis of cAMP.

A cGMP-dependent protein kinase has been isolated from bovine heart as a 150 kD dimer, with a  $K_a$  for cGMP of 10-90 nM (Flockerzi et al., 1978). It differs from its cAMP-dependent analogue in being a dimer (rather than a tetramer), and its lack of dissociation into catalytic and regulatory subunits on activation (Takai et al., 1976). A role for the cGMP-dependent protein kinase in mediating the negative inotropic effect of acetylcholine is suggested by the finding that muscarinic-induced rises in cGMP result in both increased cGMP-dependent protein kinase activity (Lincoln and Keely, 1981) and decreased inotropic effect (George et al., 1970), while nitroprusside-induced increases in cGMP do neither (Diamond et al., 1977; Lincoln and Keely, 1981). However, there have been difficulties in demonstrating specific cGMP-dependent phosphorylation in the heart (Brooker, 1977; Lincoln and Corbin, 1983). Evidence that cGMP can act independently of a protein kinase is that in single frog ventricular cells, cGMP reduced the slow inward  $Ca^{2+}$  current, while 8-bromo-cGMP had no effect (Hartzell and Fischmeister, 1986), despite the latter being five times more potent than cGMP in activating the cGMP-dependent protein kinase (Corbin et al., 1986).

Whether cGMP opposes or enhances the action of cAMP in heart is not clear. cGMP may activate the cGMP-stimulated phosphodiesterase, leading to increased cAMP hydrolysis (Beavo et al., 1982). Evidence that this is one way by which cGMP reduces the force and rate of the heart beat is

that cGMP has no effect on the basal level of the slow inward  $\text{Ca}^{2+}$  current in frog ventricular cells, but decreases it after it has been elevated by cAMP or  $\beta$ -agonists (Hartzell and Fischmeister, 1986; Fischmeister and Hartzell, 1987). A similar inhibitory action of cGMP on a catecholamine-induced  $\text{Ca}^{2+}$  current occurred in ventricular myocytes from guinea-pig (Levi et al., 1989) and rat (Mery et al., 1990; 1991). However, cGMP may inhibit cAMP hydrolysis by acting on a cGMP-inhibited phosphodiesterase, which has been isolated from bovine heart (Harrison et al., 1986). In support of this, intracellular dialysis of guinea-pig ventricular myocytes with cGMP has been shown to enhance the activity of both catecholamine-induced  $\text{Ca}^{2+}$  current (Ono and Trautwein, 1990; 1991), and chloride current (Ono et al., 1991; 1992). This action of cGMP was mimicked by milrinone, a selective inhibitor of the cGMP-inhibited phosphodiesterase, suggesting that cGMP was acting by inhibiting cAMP hydrolysis.

As post-ischaemic rises in cAMP have been associated with arrhythmias (Corr et al., 1978), the protective effect of cholinergic agonists or cardiac vagal stimulation could be explained by cGMP opposing the action of cAMP. However, studies designed to show this have not been conclusive. Injections of 8-bromo-cGMP protected against barium chloride-induced arrhythmias in rabbit hearts (Rabkin et al., 1982), but reduced rather than increased the ventricular fibrillation (VF) threshold in isolated rat

hearts (Daughtery and Woodward, 1985). These conflicting results may reflect the different conditions and methods employed (i.e. *in vivo* with chemically induced arrhythmias versus isolated hearts with electrically induced VF respectively). Later work on *in vivo* dog hearts, subjected to coronary occlusion during exercise, showed that infusions of 8-bromo-cGMP or dibutryl-cGMP protected against VF in susceptible animals (Billman, 1990). These studies did not measure the post-ischaemic concentrations of GTP or cGMP, so it was not clear whether the protective effect of cGMP analogues was due to a restoration of cGMP content following GTP depletion.

In smooth muscle cells cGMP is thought to be the second messenger which mediates the effect of EDRF and nitrovasodilators acting on the soluble form of guanylate cyclase (Furchgott and Vanhoutte, 1989), and also ANF acting on the particulate form of the enzyme (Winqvist et al., 1984). Changes in cGMP concentration may therefore be important in the control of the coronary circulation during ischaemia and post-ischaemic recovery.

#### 1.4.3 GTP and membrane fusion

Membrane fusion appears to be mediated by small GTP-binding proteins (Bourne et al., 1990). The availability of GTP may therefore be important in regulating secretion and the endo-

endo- or exocytosis of plasma membrane proteins.

Small GTP-binding proteins are found on secretory vesicle membranes isolated from bovine adrenal chromaffin cells (Burgoyne and Morgan, 1989), and guanine nucleotides appear to be essential for the exocytotic reaction in permeabilised rat mast cells (Lillie and Gomperts, 1992). Also, a GTP-binding protein controls exocytosis in yeast (Burgoyne, 1988).

GTP may be important in regulating the long-term cellular response to hormones, as this is often achieved by varying the numbers of receptors in the plasma membrane via endo- or exo- cytosis. For example, chronic exposure of turkey reticulocytes to  $\beta$ -agonists results in the down-regulation of plasma membrane  $\beta$ -receptors (Harden et al., 1980), while removal of agonist results in their reappearance (Su et al., 1980). The internalisation of insulin receptors following agonist binding is thought to be part of the signal transmission process (Yardin and Ullrich, 1988). Another GTP-dependent process is the exocytosis of the glucose transporter, which occurs in heart in response to insulin (Watanabe et al., 1984).

GTP-dependent membrane fusion may regulate the mobilisation of  $\text{Ca}^{2+}$  from intracellular storage vesicles in some cells. GTP ( $K_m = 5 \mu\text{M}$ ) enhances the  $\text{IP}_3$ -releasable  $\text{Ca}^{2+}$  pool in permeabilised hepatocytes (Thomas, 1988). In neuroblastoma

and smooth muscle cells GTP ( $K_m = 10 \mu\text{M}$ ) appears to regulate the loading of  $\text{Ca}^{2+}$  into the  $\text{IP}_3$ -sensitive  $\text{Ca}^{2+}$  pool (Mullaney et al., 1988). This has led to suggestions that GTP regulates membrane fusion or the opening of channels between  $\text{IP}_3$ -sensitive and  $\text{IP}_3$ -insensitive pools, thus controlling the quantity and/or rate of  $\text{IP}_3$ -mediated  $\text{Ca}^{2+}$  release into the cytosol. It is not clear whether this mechanism is significant in myocytes but its presence in smooth muscle cells may be important in the regulation of the coronary circulation.

#### 1.4.4 GTP and protein synthesis

Some of the energy needed for protein synthesis comes from the free energy of hydrolysis of GTP. This is mediated by the GTP-dependent cycling of various translational factors between active (GTP-bound) and inactive (GDP-bound) conformations, in a manner analogous to that for G-proteins depicted in figure 1.2. This occurs in two stages of protein synthesis; initiation and elongation, and in eukaryotes involves initiation factor 2 and elongation factors 1a and 2.

In the initiation stage, the energy of hydrolysis of GTP is used to drive the formation of a functional 70s ribosome containing bound messenger RNA and the initiating aminoacyl-tRNA. This is achieved by the GTP-dependent

activation of initiation factor 2, which promotes the association of aminoacyl-tRNA with the ribosome complex (Kaziro, 1978). In the elongation stage two GTP molecules are utilised for each amino acid added. Hydrolysis of one GTP is required to place the next aminoacyl-tRNA in the correct position, a process mediated by the activation of elongation factor 1a (Kd for GTP = 0.19  $\mu$ M) (Kaziro, 1978). Hydrolysis of another GTP provides energy for a conformational change that moves the ribosome to the next codon of the mRNA and shifts the peptidyl-tRNA from the A-site to the P-site, leaving the former site open to receive a new aminoacyl-tRNA molecule. This is mediated by the activation of elongation factor 2 (Kd for GTP = 14  $\mu$ M) (Kaziro, 1978).

The turnover rate of many myocardial proteins is several days. However, the levels of proteins such as phosphoenolpyruvate carboxykinase (PEPCK), which has a relatively short half-life (6 hours in rat liver) (Tilgham et al., 1976), may be sensitive to reduced GTP concentrations.

Reduced rates of protein synthesis have been shown to occur in ischaemic myocardium. In isolated rat hearts 30 minutes of anaerobic perfusion resulted in inhibition of protein synthesis (Jefferson et al., 1971), which was not due to inhibition of amino acid uptake. Concentrations of both ATP and GTP fell to about half their control values, although

the GTP content was still 2 or 3 orders of magnitude higher than the apparent  $K_m$  for the GTP-dependent steps. GDP inhibits the GTP-dependent reaction of chain elongation (Lin et al., 1969; Siler and Moldave, 1969), but the GDP content was unchanged in the study by Jefferson et al., suggesting an alternative cause of the inhibition. Although GMP levels increased about 3-fold, this nucleotide appears not to compete with GTP in protein synthesis reactions. A later study concluded that the inhibition of protein synthesis during anoxia was not due to lack of high energy phosphate (Lesch et al., 1976), although this was based only on measurements of adenine nucleotide content; the GTP concentration was not measured.

#### 1.4.5 Other roles of guanine nucleotides

Guanine nucleotides are required as co-factors in various reactions of intermediary metabolism, eg the succinyl-CoA reaction of the citric acid cycle (Sanadi et al., 1956), the phosphoenolpyruvate carboxykinase reaction of gluconeogenesis (Utter, 1951) and the adenylosuccinate synthetase reaction of adenine nucleotide synthesis (Maguire et al., 1972). Also, guanine nucleotides participate in the negative feedback of *de novo* purine synthesis by allosterically inhibiting the enzyme amidophosphoribosyl transferase (section 1.3.1).



## CHAPTER 2 MATERIALS AND METHODS

### 2.1 Materials

#### 2.1.1 Chemicals

Purine bases, nucleosides and nucleotides, Bovine serum albumin (fraction V), streptomycin sulphate, Trypan Blue stain, diphenylamine, Joklik Minimum Essential Medium and calf thymus DNA were obtained from Sigma Chemical Co. Ltd., Poole, Dorset, U.K.

Acetonitrile (HPLC grade) was obtained from Rathburn Chemicals Ltd. Walkerburn, Scotland.

Potassium dihydrogen orthophosphate (Aristar grade) was obtained from BDH Ltd., Poole, Dorset, U.K.

APS-hypersil 5 was purchased from Shandon Southern Products Ltd., Ashmoor, Runcorn, Cheshire, U.K.

All other reagents were Anala R grade except for the HPLC chemicals which were of Aristar grade or HPLC grade.

### 2.1.2 Enzymes

Collagenase (type II, partially purified, lyophilized powder) was obtained from Worthington Biochemical Corporation, Freehold, New Jersey, U.S.A. Hyaluronidase (Type 1-S) was obtained from Sigma Chemical Co. Ltd., Poole, Dorset, U.K.

### 2.1.3 Drugs and Hormones

Adrenaline, carbachol, mycophenolic acid and 6-mercaptopurine-ribonucleotide were obtained from Sigma Chemical Co. Ltd., Poole, Dorset, U.K. Ribavirin was kindly donated by Dr. N. Snell of Britannia Pharmaceuticals U.K. Redhill, Surrey, U.K.

### 2.1.4 Animals

Albino male rats, from an original Sprague-Dawley strain, were either purchased from Charles Rivers and Co., U.K. Ltd., Margate, Kent, or bred and maintained in the Biochemistry Department, Joint Animal House, University College London and were allowed food (RM3 S.D.S. diet, Special Diets Services, Wickham, Essex, U.K.) and water *ad libitum*. Rats were deprived of food but not water overnight before sacrifice. The weight of the rats when used was 200-

250g.

#### 2.1.5 Other Materials

Pressurised gases (95%O<sub>2</sub>/5%CO<sub>2</sub>; O<sub>2</sub>-free nitrogen) were supplied by British Oxygen Co. Ltd., London, U.K. Millipore filters, type GS 0.22um pore size were obtained from Millipore Corporation, Bedford, Massachusetts, U.S.A.

#### 2.2 Statistical analysis

The probability (p) that two samples were part of the same population was determined using Student's t-test, incorporating Bessel's correction for small populations. The samples were initially assumed to be drawn from populations identical with respect to mean and variance (the null hypothesis), but if p was less than 0.05 then the samples were considered unlikely to be part of the same population, i.e. they were significantly different. Values of t were calculated as shown on the following page.

$$t = \frac{\bar{x}_1 - \bar{x}_2}{\left[ \frac{n_1 s_1^2 + n_2 s_2^2}{n_1 + n_2 - 2} \cdot \left( \frac{1}{n_1} + \frac{1}{n_2} \right) \right]^{1/2}}$$

where  $n_1$  and  $n_2$  are the number of observations used to determine the standard deviations  $s_1$  and  $s_2$  of the samples with means  $\bar{x}_1$  and  $\bar{x}_2$  respectively.

The stochastic dependence of two random variables  $x$  and  $y$  was assessed by calculating the best estimate of the correlation coefficient ( $r$ ) from the following expression:-

$$r = \frac{\sum xy - \bar{x} \cdot \bar{y} \cdot n}{s_x \cdot s_y \cdot (n-1)}$$

where  $\bar{x}$  and  $\bar{y}$  are the means, and  $s_x$  and  $s_y$  the standard deviations, of the variables  $x$  and  $y$  respectively determined from  $n$  observations of the sample. To test whether the value of  $r$  was significantly different from zero, the significant limits of  $r$  were found from a published table based on Student's  $t$ -test.

## 2.3 Heart perfusions

Rat hearts were perfused by the Langendorff technique with blood-free bicarbonate medium, using the method of Mowbray (1969).

### 2.3.1 Media

(a) Perfusion medium. This was the Ringer-bicarbonate buffer of Krebs and Henseleit (1932), except that it contained only half the recommended concentrations of calcium and magnesium. This more closely approximates to the situation in whole blood, in which 35-45% of these ions are bound to plasma proteins (Green and Power, 1931). The composition of the perfusion medium was as follows:-

120 mM NaCl, 4.8 mM KCl, 1.2 mM  $\text{KH}_2\text{PO}_4$ , 0.6 mM  $\text{MgSO}_4$ , 1.3 mM  $\text{CaCl}_2$ , 25.3 mM  $\text{NaHCO}_3$  and 5.5 mM D-glucose.

Concentrated solutions of each of the components were stored at 4°C and mixed together and diluted on the day of perfusion. Streptomycin sulphate (0.1 gram/litre) was also added to inhibit the growth of bacteria. The perfusion medium was equilibrated with 95% $\text{O}_2$ /5% $\text{CO}_2$  and had a pH of 7.4 at 37°C.

(b) Cooling medium. This had the same ionic composition as perfusion medium except that the  $\text{NaHCO}_3$  concentration was reduced to one-third, so that it had a pH of 7.4 without

O<sub>2</sub>/CO<sub>2</sub> gassing. Cooling medium contained 55 mM D-glucose and was cooled to 4-6°C before use.

(c) Cleaning fluid. The perfusion apparatus was cleaned regularly with a solution containing 165g NaCl and 10 ml sodium hypochlorite solution (10-14% w/v available chlorine) per litre of distilled water. The solution was stored in the dark.

### 2.3.2 Perfusion apparatus

The apparatus consisted essentially of a system for delivering oxygenated medium at 37°C from a reservoir to the isolated heart at a constant perfusion pressure and reoxygenation of the effluent perfusate before its return to the reservoir. The system is represented diagrammatically in figure 2.1., to which the following description refers.

The reservoir (A) contains perfusion medium in equilibrium with O<sub>2</sub>/CO<sub>2</sub> (95%:5%) and allows sampling of both phases through the side-arms (B) which are sealed with suba-seal injection mouldings (A. Gallenkamp and Co. Ltd., London, U.K.). The magnetic stirrer (C) ensures continuous mixing of the contents and constant temperature is maintained by a water jacket. The medium is taken from the bottom of the reservoir through tygon autoanalyser tubing of 0.065 inches

internal diameter (Technicon Instrument Co. Ltd., Basingstoke, Hants, U.K.) by a Masterflex peristaltic pump (D) (Cole-Palmer Instrument Co., Bishops Stortford, Herts, U.K.). It is pumped through a perspex filter housing (E) which contains a 20 mm diameter porosity 3 scintered glass disc (Jobling Laboratory Division, Stone, Staffs., U.K.) to remove small particles from the medium which might cause coronary embolism (Bleehen and Fisher, 1954).

The flow beyond the filter is split into two parts at the junction (F), one proceeding to the pressure diaphragm (G) and the other to the cannula (H), to which the aorta of the heart is attached. The cannula is provided with a bubble trap (I) to ensure that the medium entering the heart is free of gas bubbles.

The pressure diaphragm (G) consists of a perspex housing through the front of which input and output tubes pass to terminate flush with the inside face. Across this face is stretched a piece of rubber balloon which acts as a diaphragm. The back of the housing has an opening leading via vinyl tubing to a manometer system. Air is pumped into this system to exert a known pressure on the diaphragm. To pass from the input to the output side the perfusion medium must attain a flow pressure slightly in excess of the pressure exerted on the diaphragm by the air in the manometer. This will be approximately equal to the pressure exerted at the aorta of the heart.

Legend to figure 2.1

|   |                         |
|---|-------------------------|
| A | Gas/perfusate reservoir |
| B | Sampling sidearms       |
| C | Magnetic stirrer        |
| D | Peristaltic pump        |
| E | Filter housing          |
| F | Junction                |
| G | Pressure diaphragm      |
| H | Cannula                 |
| I | Bubble trap             |
| J | Heart chamber           |
| K | Junction                |
| L | Junction                |
| M | Diagonal tube           |

The arrows represent the water-jacket inlets and outlets.



Figure 2.1 Diagrammatic representation of the perfusion apparatus

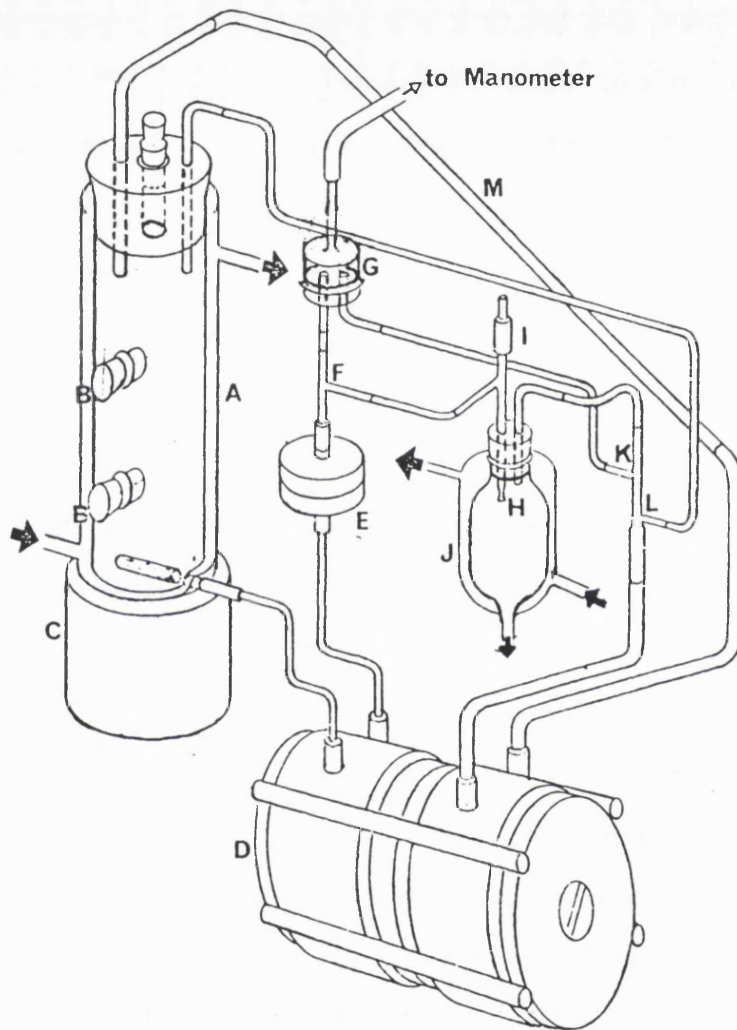

Medium leaving the heart fills the water-jacketed heart chamber (J), thus bathing the heart and overflows into the output tube joining with the pressure diaphragm outflow at junction (K). The medium proceeds to junction (L) from where it is pumped through tygon autoanalyser tubing of increased i.d. (0.110 inches) by the second channel of the pump. The larger capacity of this tubing is accommodated by gas drawn in at junction (L) from the upper part of the reservoir (A), so that the perfusion medium is interspersed with bubbles of gas.

As the gas-liquid mixture flows up the diagonal glass tube (M) back to the reservoir, continuous relayering of the medium occurs along the tube exposing a larger surface area to the gas phase, resulting in rapid reoxygenation of the medium. This system can equilibrate air saturated perfusate with 95% O<sub>2</sub> in 13 minutes, when the total flow rate is 50 ml/min (Mowbray, 1969). With a heart in the perfusion system the oxygen tension of the medium entering the heart, measured with an oxygen electrode in the input line (see section 2.5), was constant at  $0.906 \pm 0.005$  mM after 20 minutes of perfusion.

### 2.3.3 Perfusion procedure

#### 2.3.3.1 Conditions

The water jackets of the reservoir and heart chamber were supplied with continuously circulating water from a Braun Thermomix II water heater/pump (F.T. Scientific Instruments Ltd., Camberley, Surrey U.K.) at a temperature which ensured that the medium leaving the reservoir was at 37°C. The reservoir was primed with perfusion medium, which was gassed with premoistened O<sub>2</sub>/CO<sub>2</sub> (95%:5%) through a hypodermic needle inserted into the lower sampling side-arm of the reservoir. The gas pressure was adjusted so that the small glass stopper in the top of the vessel floated in the escaping gas stream. The peristaltic pump speed was adjusted so that the overall flow rate through the system was 50 ml/min and the perfusion pressure was chosen to be 70 cm H<sub>2</sub>O (except where otherwise stated), as discussed by Mowbray (1969).

#### 2.3.3.2 Heart cannulation and perfusion

Sprague-Dawley rats were starved overnight and brought to the laboratory at least one hour before the experiment was begun. Each rat was lightly anaesthetised in an ether/air atmosphere, the heart rapidly excised from the thoracic cavity and plunged into about 50 ml of cooling medium in an

evaporating basin. The heart was squeezed gently two or three times and agitated to disperse the extruded blood. When the heart had stopped beating (3-5 seconds after excision) it was transferred to fresh cooling medium and trimmed free of adhering fat pad and pericardium. The aorta was trimmed to just below its first branch and inspected to ensure that the semilunar valve was intact and that it was free of blood clots. The atria were left intact. The heart was blotted to remove most of the medium and weighed by dropping it into a preweighed beaker of cooling medium.

The flow of perfusion medium from the cannula was reduced to a trickle by clamping the input line and the cannula tied into the aortal stump so that it did not penetrate far enough to occlude the coronary arteries. The clamp was released and the heart perfused without recirculation for 10 minutes, in order to wash out blood (the preperfusion period). This period of preperfusion is also sufficient to wash out endogenous hormones, although some endogenous substrates, such as free fatty acids, will still be present (Mowbray, 1969). The presumed effect of endogenous insulin on glucose utilisation is markedly reduced if perfusion is preceded by a 10-15 minute period of non-recirculating preperfusion, or if the heart is taken from a fasted rat (Fisher and O'Brien, 1972). The combination of overnight fasting and 10 minute washout period should therefore result in insignificant levels of endogenous insulin. Likewise, the washout period removes the endogenous

catecholamines from the heart (Fisher and Williamson, 1961).

The heart began to beat spontaneously at the onset of preperfusion and had usually settled to a steady regular beat after 5 minutes. If the beat remained unsteady or undispersed blood clots could be observed (discoloured areas of tissue) then the heart was discarded.

At the end of the preperfusion period the flow of the medium into the cannula was interrupted and the cannula assembly rapidly transferred to a second perfusion apparatus where the flow was immediately restored. This operation took less than 5 seconds. The medium leaving the heart was now recirculated and the moment of flow restoration was denoted as zero perfusion time. The recirculating system initially contained 50 ml of perfusion medium with appropriate additions, but this would be diluted by about 1.5 ml by medium carried over during the transfer of the cannula and heart (Mowbray, 1969).

Hearts were then perfused according to the various protocols described in chapter 3 to test the effects of ischaemia on purine nucleotide concentrations and the effect of GTP concentration changes on mechanical performance and response to drugs and hormones.

#### **2.3.3.3 Introducing ischaemia**

Hearts were recirculation perfused for 20 minutes to allow them to settle down to a steady state. Global no-flow ischaemia was then applied for set periods of time by clamping the tube leading to the cannula. Hearts stopped beating within 1-2 minutes of the onset of ischaemia and usually resumed beating 2-3 minutes after the start of reperfusion.

#### **2.3.3.4 Application of drugs and hormones**

Concentrated solutions were made up in a suitable vehicle and injected through the lower side-arm of the reservoir into the bulk of the perfusion medium to give the appropriate final concentration as indicated in chapter 3 section 3.6.

#### **2.3.3.5 Electrical pacing**

The endogenous cardiac pacemaker was removed by cutting off the atria. Hearts were then paced at 250 mV, 4 cycles per second, by inserting electrodes into the apex of the heart immediately following cannulation.

#### 2.4 Measurement of heart beat rate and amplitude

The beat rate and amplitude of perfused hearts were measured by connecting the heart to a Statham pressure transducer situated above the heart chamber. A modified heart cannula assembly was designed to allow a length of thread from the pressure transducer to be connected to the apex of the heart, so that movements of the heart were transmitted to the transducer, whilst the perfusion system remained sealed. A diagram of the modified cannula assembly is shown in figure 2.2. The signal from the transducer was displayed on a chart recorder with a fast response time (Grass model 5D polygraph, Grass Instruments Co., Quincy, Massachusetts, USA).

The perfusion procedure was as described previously (section 2.3.3.) except that a length of thread was attached to the apex of the heart before it was mounted on the cannula. At the end of the preperfusion period, the cannula assembly was transferred to a second perfusion apparatus as before and the thread attached to the pressure transducer. The rubber balloon, B (fig 2.2), was tied so that it sealed around the thread and the transducer was elevated on a rack and pinion mounting until the lowest point of the pen deflection was at zero on the pen recorder scale. The range control was adjusted so that the deflection of the pen covered approximately one-third of the scale. This procedure was completed within about 4

minutes and thus the first reading was taken after 5 minutes of perfusion. The position of the transducer and the settings of the pen recorder controls were not altered again during the perfusion, except by a known factor (i.e. by adjustment of the offset and range controls).

Readings were taken according to the protocols described in the results chapter (section 3.6). Heart rate was calculated by counting the number of strokes of the pen recorder over a 20 or 30 second period. The amplitude of the heart beat was measured from the average deflection of several strokes of the pen using the recorder at a speed of 6 mm/sec. Since the initial positioning of the pressure transducer was somewhat arbitrary and the actual tension depended on heart shape and the position of the ligature and thus varied from one perfusion to the next, the true amplitude of the heart beat was not found. The response to drugs was therefore expressed as the percentage change in the average pen deflection between pre- and post-drug steady states, typical traces being shown in figure 2.3.



Legend to figure 2.2

|   |                               |
|---|-------------------------------|
| A | Thread to pressure transducer |
| B | Rubber balloon                |
| C | Bubble trap                   |
| D | Outlet tube                   |
| E | Rubber stopper                |
| F | Position of heart             |
| G | Cannula                       |

The arrows represent the direction of flow of medium.

**Figure 2.2** Diagrammatic representation of the modified cannula assembly

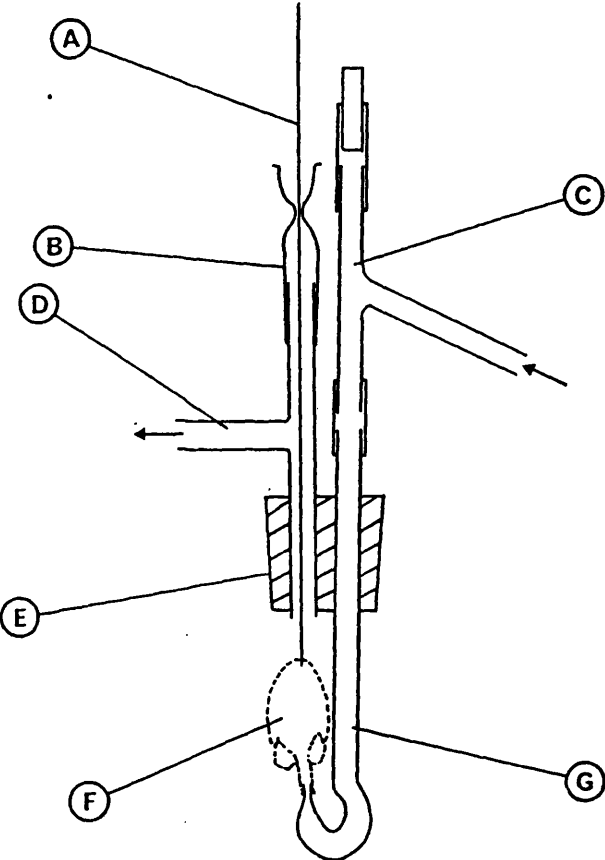

### Legend to figure 2.3

The figure shows the pen recorder trace of the output from the pressure transducer, which had been connected to a perfused heart as described in section 2.4. The pen recorder speed was set at 6 mm/sec. At time  $t=0$ , adrenaline ( $10^{-7}$  M) was added to the medium perfusing the heart. The 30 second time lag before a response was seen was mostly due to the time taken for the adrenaline to circulate from the reservoir to the heart.

Figure 2.3 Heart beat record of perfused heart treated with  $10^{-7}M$  adrenaline

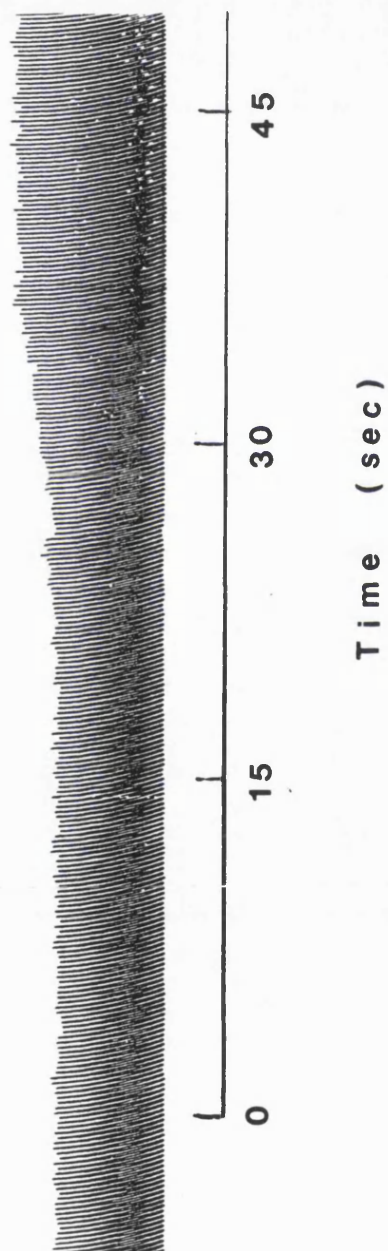

## 2.5 Measurement of oxygen consumption by perfused heart

Oxygen consumption by perfused rat hearts was measured by placing oxygen electrodes in the perfusion system immediately before and after the heart cannula assembly (see fig 2.1). Each electrode consisted of a YS1 5331 oxygen probe (Yellow Springs Instrument Co., Ohio, USA) set in a perspex flow-through unit as described by Mowbray (1969). The output voltages of the electrodes were displayed on a 10 mV two channel pen recorder (Elektronik 15 recorder, Honeywell Controls Ltd., London, UK) after suitable amplification and the scale calibrated using the difference between the output voltage obtained in the presence of buffer at 37°C equilibrated with O<sub>2</sub>/CO<sub>2</sub> (95%/5%), pH 7.4 and that obtained after adding 10 mg of sodium dithionite. From Henry's law the concentration of O<sub>2</sub> under these conditions (in the absence of dithionite) is 1.012 mM.

The flow rate of medium through the heart was determined from the time taken for a gas bubble to traverse a known length of standard bore tygon autoanalyser tubing, incorporated into the perfusion system after the second oxygen electrode but before junction K (fig 2.1), as described by Mowbray (1969). The rate of oxygen consumption by the heart could then be calculated from the drop in oxygen concentration of the perfusion medium between the two electrodes and the flow rate.

A typical pen recorder trace of the oxygen electrode output voltages during the first 30 minutes of a heart perfusion is shown in figure 2.4.

## 2.6 Homogenisation and extraction of tissue

At the end of perfusion hearts were rapidly frozen by clamping between aluminium plates cooled to the temperature of liquid nitrogen ( $-196^{\circ}\text{C}$ ) (Wollenberger et al., 1960), and then homogenised at  $-10^{\circ}\text{C}$  (on an ice/salt mixture) in 2 ml of an aqueous solution of 10% (w/v) trichloroacetic acid (TCA) and 25% (v/v) methanol with an Ultra-Turex homogeniser (model TP 18-10 Janke and Kunkel, Staufen i.b. Germany). The homogeniser was washed with another 2 ml TCA-methanol at  $-10^{\circ}\text{C}$ . An homogenous mixture of tissue and extraction medium was obtained at the sub-zero temperature by using methanol, thus ensuring that enzymes remain inactive prior to denaturation with the acid. The methanol may also serve to inactivate creatine kinase and adenylate kinase, which are not denatured by acid treatment alone (Williamson and Corkey, 1969).

The homogenate was centrifuged in a Sorvall high speed refrigerated centrifuge (Sorvall RC 5B Du Pont Instruments), at 17,000 r.p.m. (SM 24 rotor 9,000 x g) for 5 minutes at  $4^{\circ}\text{C}$  to pellet the denatured protein. The volume of the supernatant was recorded and it was freed of TCA and methanol by extraction with 3 x 4 vol. water saturated

#### Legend to figure 2.4

The figure shows a typical pen recorder trace during perfusion of the output voltages from the two oxygen electrodes situated in the perfusion system on each side of the cannula assembly (see section 2.5). The left-hand trace is from the second electrode which is situated after the heart and the difference between the two traces represents the oxygen consumption by the heart. Following the addition of adrenaline ( $10^{-7}$  M) to the perfusate (at time  $t=0$ ) the oxygen consumption by the heart increases, as can be seen by the reduction in the output voltage of the second electrode.

Figure 2.4 Oxygen electrode trace during a heart perfusion

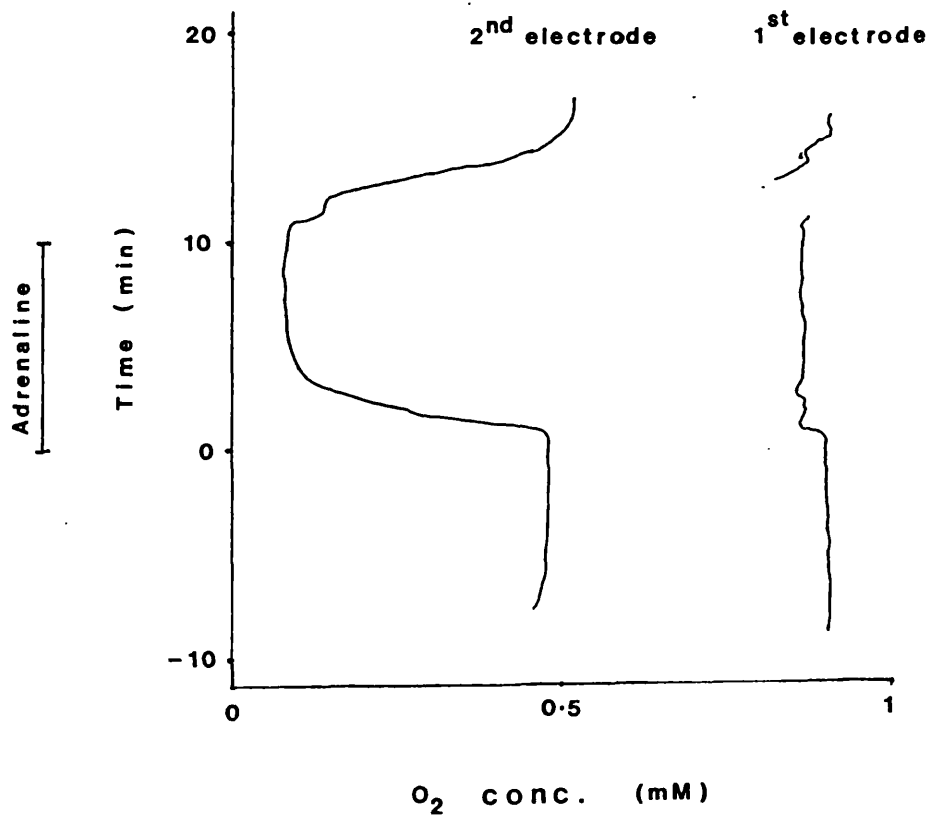



diethylether and the pH adjusted to 6.5-7.0 using Tris-base crystals. The neutralised extract was then stored at -70°C for up to 2 months before analysis. Purine nucleotides in similar extracts of rat heart are stable for at least 3 months at -20°C (Bates, 1978). Samples of perfusate were also retained for analysis of purine nucleotide degradation products and stored at -70°C.

## **2.7 Measurement of purine nucleotides, nucleosides and bases using high pressure liquid chromatography (HPLC)**

### **2.7.1 Anion-exchange HPLC**

Neutralised heart extracts were analysed by anion-exchange HPLC to determine their purine nucleotide and nucleoside content. This was done using a 15 cm x 4 mm column packed with APS-Hypersil 5 (weak anion-exchanger) and a Gilson 303 system (supplied by Anachem, Luton, Beds., UK.). The system was provided with a guard column (4 cm x 4 mm) packed with the same material. 20-100  $\mu$ l samples were applied to the column equilibrated at room temperature with 1 mM  $\text{KH}_2\text{PO}_4$ , pH 3 (buffer A) and developed at 1.5 ml/min (200 Bar pressure) with a gradient rising to 400 mM  $\text{KH}_2\text{PO}_4$ , pH 3 (buffer B) after about 15-20 minutes. The actual gradient profile used was varied from time to time to improve the resolution of closely spaced peaks or to compensate for decreases in

retention times which occurred with increasing use of the column. A particular problem was the difficulty in separating AMP from NAD<sup>+</sup> and adenosine from inosine and other nucleosides. This was overcome in most cases by applying a shallow gradient for the first 10 minutes and then increasing the gradient so that the maximum salt concentration (400 mM) was obtained after 20 minutes. A typical gradient profile used was as follows:

| Time (min) | % buffer B (400 mM KH <sub>2</sub> PO <sub>4</sub> ) |
|------------|--|
| 0          | 0  |
| 10         | 25   |
| 20         | 100  |
| 22         | 100  |
| 24         | 0  |

The buffers were filtered through a 0.22  $\mu$ M Millipore filter type GS and degassed under vacuum (25 mm Hg, Millipore pump) before use. The eluate was monitored at 259 nm with a Gilson HM Holochrome UV detector equipped with an 11  $\mu$ l flow cell. The detector response was recorded on a Hewlett-Packard recorder (Hewlett-Packard, Avondale, PA. U.S.A.) and the peaks integrated on a Gilson Datamaster 620 integrator. A standard containing 10 nmole of each nucleotide was run under the same conditions each time, and the elution peaks of the extracts were identified by comparison of their retention times with those of the

standards. The concentration of each nucleotide was determined by comparing the area under its elution peak with that of the corresponding standard. Figure 2.5 shows the profile of a typical nucleotide standard and figure 2.6 shows the profile of typical samples from a control heart and a heart subjected to 20 minutes of global no-flow ischaemia.

### 2.7.2 Reverse-phase HPLC

Following some initial problems in obtaining good resolution of the peaks for nucleosides and other breakdown products such as hypoxanthine, it was decided to use a reverse phase column to obtain better separation of these substances. This was of particular use when analysing the nucleotide breakdown products in myocyte incubations (see section 2.8), where the concentrations in the tissue extracts were considerably lower than in the extracts from whole hearts. The column measured 25 cm x 4.6 mm and was packed with APEX ODS II 5U (Jones Chromatography, Mid Glamorgan, U.K.). The guard column measured 5 cm x 4.6 mm and was packed with similar material. The pumps, UV detector and integrator were the same as those used for the anion-exchange column described above. 20-100  $\mu$ l samples were applied to the column equilibrated at room temperature with 0.5 M succinate, 50 mM  $\text{KH}_2\text{PO}_4$  and 1% v/v  $\text{CH}_3\text{CN}$ , pH 4 (buffer A) and developed at 1.5 ml/min (200 Bar pump

pressure) by increasing the concentration of CH<sub>3</sub>CN to 4% v/v (buffer B) over a period of 8 minutes, the gradient profile being as follows:-

| Time (min) | % buffer B (4% v/v CH <sub>3</sub> CN) |
|------------|--|
| 0          | 0                                      |
| 4          | 0                                      |
| 12         | 100                                    |
| 17         | 100                                    |
| 19         | 0                                      |

Buffers were filtered and degassed as described above. The eluate was monitored at 259 nm and the nucleotide breakdown products identified and quantified by comparison with known standards as described above for the anion-exchange column. A typical sample profile is shown in figure 2.7.

## Legend to figures 2.5 and 2.6

Figure 2.5 shows the separation of nucleotide standards by anion-exchange HPLC. 10 nmole of each standard was injected onto an APS-Hypersil anion-exchange column and eluted at a flow of 1.5 ml/min with 400 mM phosphate buffer, pH 3.0 and the absorbance recorded at 259 nm, as described in section 2.7.

Figure 2.6 shows the separation of nucleotides and nucleosides following application of 100  $\mu$ l of neutralised soluble heart extract to the column under the conditions described above. The upper trace is from a control heart and the lower trace is from a heart that had been subjected to 20 minutes of global no-flow ischaemia.

On both figures the dotted line shows the change in % of buffer B with time.

Figure 2.5 Anion-exchange HPLC profile of purine nucleotide standards

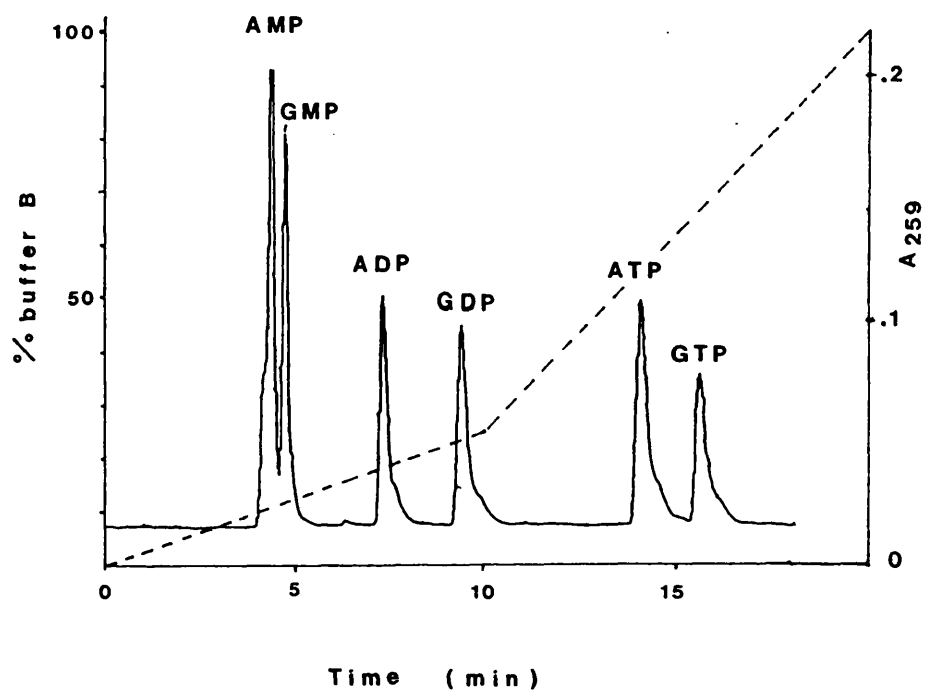
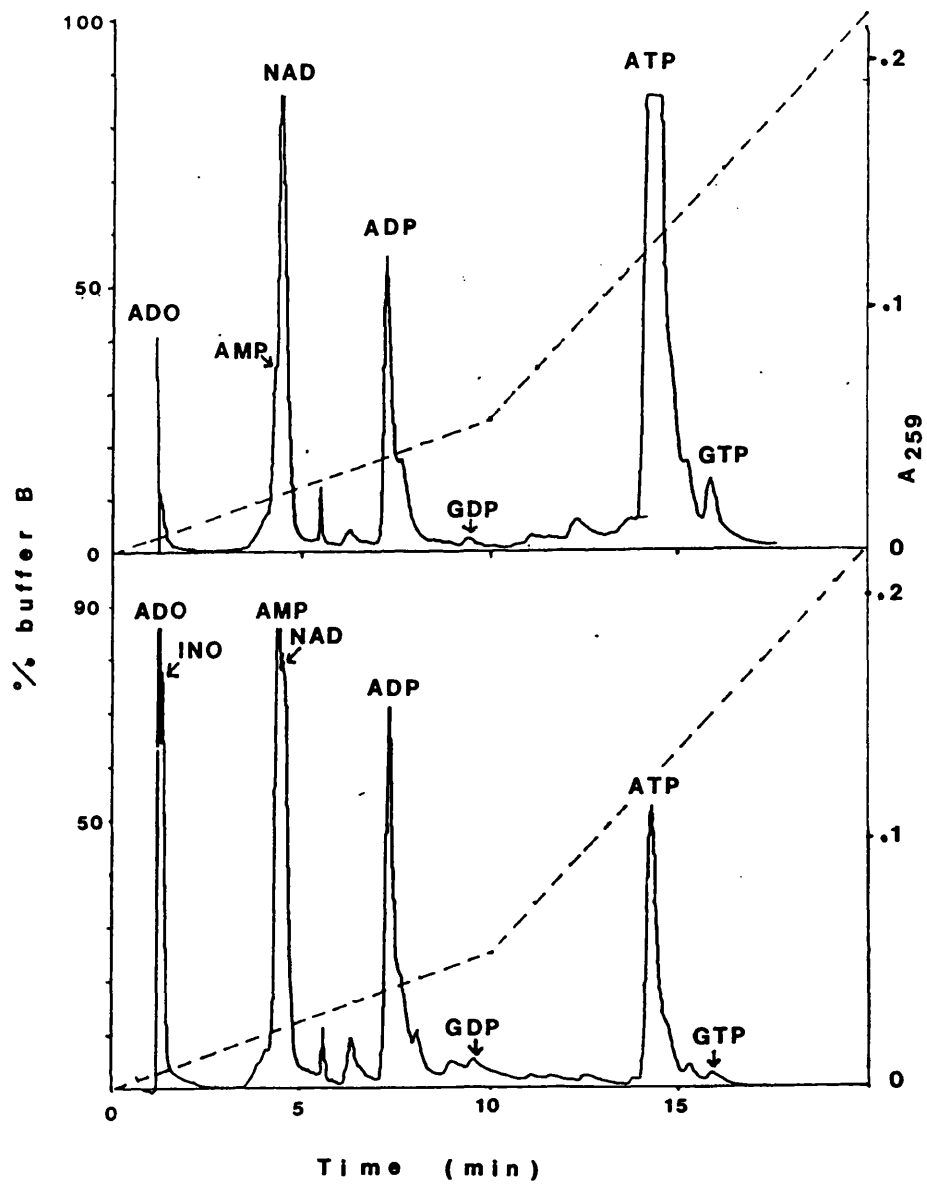

Figure 2.6 Anion-exchange HPLC profiles of TCA-soluble extract of perfused rat hearts



Legend to figure 2.7

100  $\mu$ l of neutralised soluble myocyte extract was applied to an APEX ODS II 5U reverse-phase column and eluted at a flow of 1.5 ml/min with 0.5 M succinate/50 mM phosphate buffer, pH 4.0, with acetonitrile rising from 1% to 4% v/v and the absorbance recorded at 259 nm, as described in section 2.7. The trace shown is from a control heart. The dotted line shows the % change in buffer B with time.



Figure 2.7 Reverse-phase HPLC profile of TCA-soluble extract of perfused rat heart

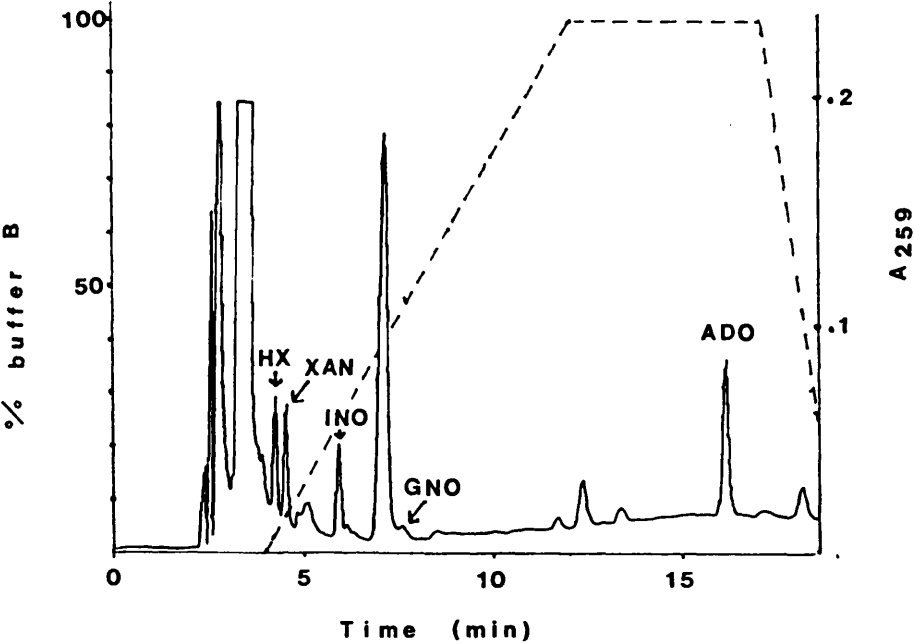

## 2.8 Measurement of cyclic GMP by radioimmunoassay

The assay is based on competition between unlabelled cGMP and a fixed quantity of the tritium labelled compound for binding to an antiserum which has a high specificity and affinity for cGMP. In the Amersham RIA kit the amounts of other nucleotides required to cause the same inhibition of cyclic[ $^3\text{H}$ ]GMP binding to the antiserum as 0.8 pmol of cGMP are: 25 000 pmol GMP, GDP or GTP; 120 000 pmol cAMP; and greater than  $10^6$  pmol AMP, ADP or ATP (manufacturer's specifications). The detection limit is given as 0.04 pmol per incubation (two standard deviations at zero dose), and the assay is free from interference by a number of salts, metal ions, phosphodiesterase inhibitors and other materials likely to be present in biological samples.

Freeze dried heart extracts were redissolved in 0.5 ml of 50 mM Tris-HCl buffer pH 7.5 containing 4 mM EDTA, and 100  $\mu\text{l}$  duplicate samples assayed for cGMP content using the Amersham RIA kit as directed. This essentially involved incubating samples with cyclic[ $^3\text{H}$ ]GMP and an antiserum to cGMP, and determining the amount of radioactively labelled cGMP bound to the antibody after its precipitation with ammonium sulphate. The precipitated antibody was dissolved in 1 ml distilled water and assayed for radioactivity in 10 ml scintillant B using a Packard Tri-Carb 1900CA analyser (Canberra Packard, Pangbourne, Berks., UK.). Scintillant B had the following composition (Patterson and Greene, 1965):

0.4% (w/v) BBOT in Triton X-100:toluene (1:2 v/v).

All samples were counted in low potassium glass vials and all analyses were performed in duplicate.

The blank reading, due to the free cyclic[ $^3\text{H}$ ]GMP unbound by antibody, was subtracted from all the other data. The counts per minute (cpm) bound in the absence of unlabelled cGMP (zero-dose binding) was designate  $C_0$ , and the cpm bound in the presence of unlabelled cGMP (standard or unknown sample) was designated  $C_x$ . The ratio  $C_0/C_x$  was calculated for all samples, and the amount of cGMP in the unknowns determined by interpolation of a calibration curve of  $C_0/C_x$  versus the amount of unlabelled cGMP (fig 2.8).

Counting efficiency was determined by quench correction using the external standard Barium source ( $^{133}\text{Ba}$ ) of the analyser. Scintillation fluid containing n- $^3\text{H}$ hexadecane of known specific radioactivity was quenched by the sequential addition of 0.1 ml aliquots of chloroform, and counted against the external standard (A.E.S.) after each addition. The counting efficiency calculated from the count rate (c.p.m.) and the dpm of the radioactive n-hexadecane was plotted against the A.E.S. printed by the counter to obtain a quench correction curve. This curve was used to determine the counting efficiency of unknown samples in the scintillant. Counting efficiency for  $^3\text{H}$ -labelled samples was 22%.

The freedom of the assay from interference by substances in the heart extracts was tested against the following criteria, which have been used by various authors in the assessment of assays for cyclic nucleotides using binding proteins (Gilman, 1970; Brown et al. 1971; Tovey et al. 1974):

- (1) complete recovery of internal standards added to extract samples;
- (2) linearity of the amount of nucleotide measured with increasing sample volume; and
- (3) proof of zero interference by cyclic nucleotide free extracts (i.e. phosphodiesterase treated).

The recovery of known amounts of cGMP added to heart extracts was complete (figure 2.9a). The values for cGMP recovered were obtained by subtracting the amount of cGMP in the sample alone from that measured in the presence of added cGMP. The cGMP content measured in heart extracts after subtraction of the phosphodiesterase blank value was linearly related to the volume of the sample up to 100  $\mu$ l (figure 2.9b). Finally, heart extract samples were incubated with phosphodiesterase for 30 minutes at 37°C and were then assayed for cGMP after denaturation of the phosphodiesterase by heating to 100°C. This treatment was completely effective in hydrolysing standard cGMP in both the absence and presence of heart extract. Samples freed of cGMP in this way apparently contained material which

interfered with the assay. For each set of perfusions three extracts were selected at random and assayed after phosphodiesterase treatment, and their mean value (phosphodiesterase blank value) was subtracted from the cGMP measured in the experimental samples. This value was usually about 25% (15% to 45%) of the sample value, which ranged from 1 pmol to 3 pmol cGMP per assay.

Legend to figures 2.8 and 2.9

Figure 2.8 shows a standard curve obtained by carrying out the cGMP assay procedure, as described in the text, in the presence of varying amounts of non-radioactive cGMP of known concentration.

$C_0$  = counts per minute bound in the absence of unlabelled cGMP.

$C_x$  = counts per minute bound in the presence of unlabelled cGMP standard.

Figure 2.9 (a) shows the cGMP content of 100  $\mu$ l samples of a heart extract to which increasing amounts of standard cGMP had been added.

Figure 2.9 (b) shows the cGMP content in varying volumes of two different heart extracts.

Figure 2.8 Standard curve for cGMP radioimmunoassay

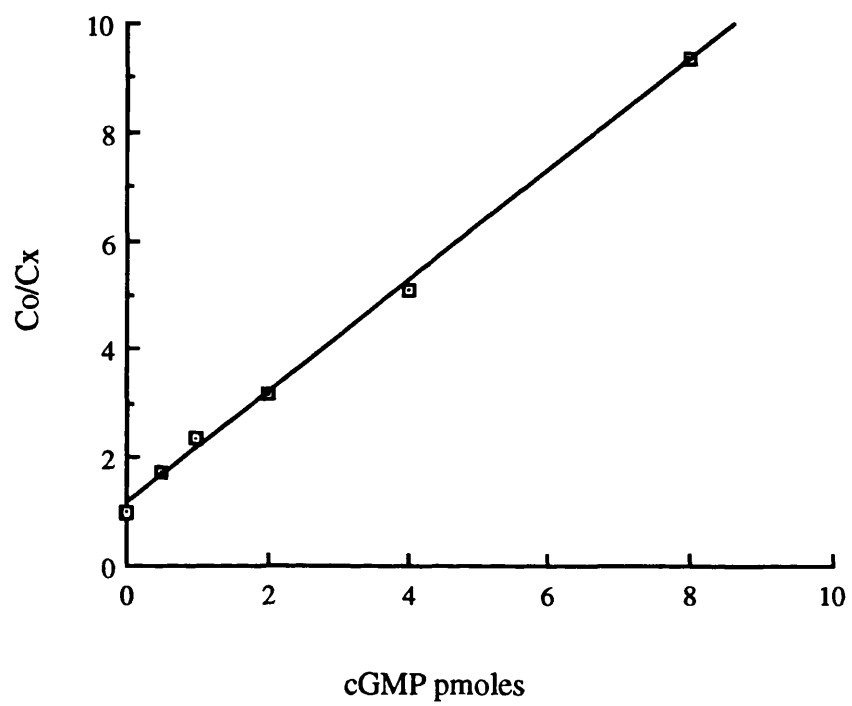
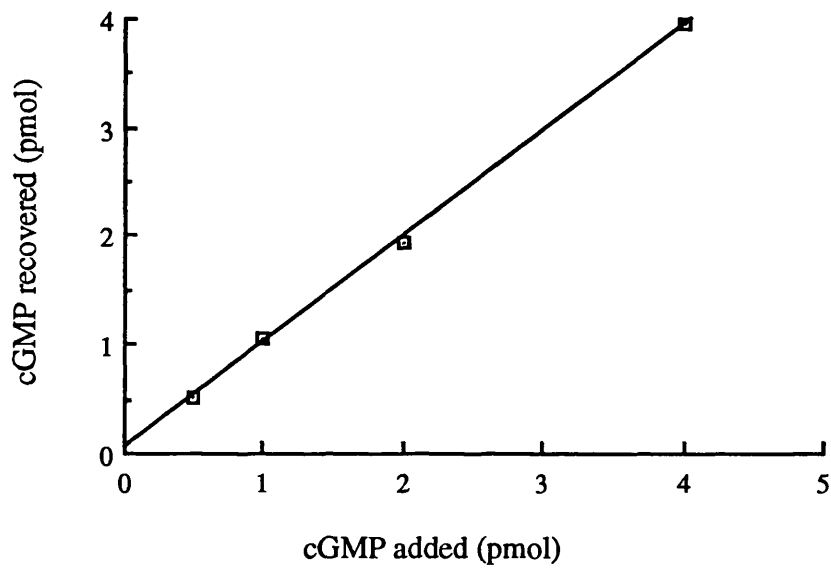
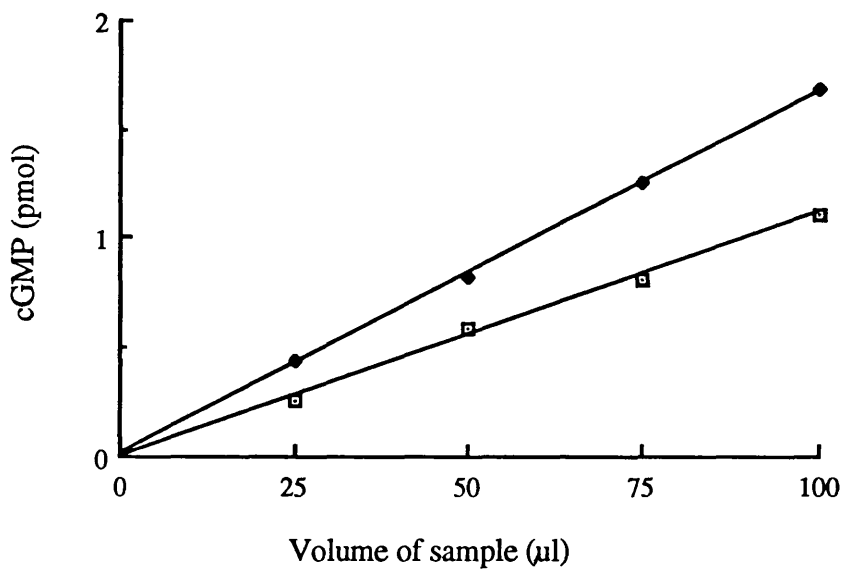

Figure 2.9 Measurement of cGMP in heart extracts by the radioimmunoassay

(a)



(b)





## 2.9 Experiments on isolated myocytes

### 2.9.1 Isolation of myocytes

To investigate the role played by various cell types in cardiac guanine nucleotide metabolism, it was considered necessary to isolate viable calcium-tolerant ventricular myocytes from adult rats. For these experiments the following requirements needed to be met:-

(i) The myocyte preparation should be free of other cell types such as endothelial cells.

(ii) The cells should be metabolically viable (as determined by indicators such as the ATP/ADP ratio and morphological characteristics).

(iii) There should be a high enough yield (both as number of cells per ml and viable cells as % of total cells) to obtain accurate measurements of the content of guanine nucleotides and breakdown products.

(iv) Metabolic viability should be stable for a reasonable period of time (at least 2 hours) so that the effects of hypoxia or drugs could be assessed.

A successful technique for the isolation of calcium-

tolerant adult rat ventricular myocytes was first described by Powell and Twist (1976) and subsequently many groups have reported similar successes based on this method or modifications of it (eg see Dow et al., 1981; Piper et al., 1982). The basis of the method is to perfuse hearts in calcium-free bicarbonate buffer for 4-5 minutes followed by perfusion in the presence of collagenase and micromolar quantities of calcium, which acts as a co-factor for collagenase. Physiological (millimolar) concentrations of calcium are then re-introduced gradually. It is thought that during the initial calcium-free perfusion the cells part at their intercalated disc region and that subsequently the collagenase breaks down the intercellular connective tissue thus releasing the cells (Powell and Twist, 1976). The endothelial cells are thought to be washed out of the heart during this process. The presence of micromolar concentrations of calcium during perfusion with collagenase, followed by the gradual re-introduction of physiological concentrations of calcium, appear to avoid the so called 'calcium paradox' (Haworth et al., 1989). This is the rapid loss of ordered structure and loss of contractile activity which are seen following the sudden re-introduction of physiological concentrations of calcium after perfusion in calcium-free media (Zimmerman, et al., 1967), and is thought to be due to the need for a minimal calcium concentration to heal small sarcolemmal disruptions to the intercalated discs which occur during cell separation (Berry et al., 1970).

Various methods and protocols based on the above principles were tested before one was found which produced reasonably consistent results. This was a modified form of the method used by Dr M Crompton and co-workers of the department of biochemistry and molecular biology UCL, which itself was based on a method described by Haworth et al., (1989), in which calcium is re-introduced to the circulating perfusate 15 minutes after addition of collagenase. The main modification adopted for this thesis was that Joklik minimum essential medium (MEM) rather than Krebs-Henseleit buffer was used during cell purification and for the experimental incubations. This was found to result in greater long-term cell viability (as indicated by maintenance of the ATP concentration and ATP/ADP ratio over 2 hours) than when Krebs-Henseleit solution was used. The method is described in detail below. Another method tested was that described by De Young et al., (1989), which uses Joklik MEM throughout the perfusion and isolation procedure as well as for the experimental incubations; in our hands this gave very low cell yields.

Another important factor is the variability in yields obtained using different batches of collagenase. From early attempts to isolate viable myocytes it has been found that purified collagenase is not very effective (Glick et al., 1974) and that the presence of proteinases in 'crude' collagenase is probably necessary for successful results. Four batches of collagenase (type II) were tested under

identical conditions before one was found which gave consistently satisfactory yields. This batch was then ordered as several 1 gram aliquots and stored at 4°C.

#### **2.9.1.1 Media**

Cooling and perfusion media were as described for heart perfusions in section 2.3.1. except that calcium chloride was omitted from the perfusion medium to render it nominally calcium-free. Joklik minimum essential medium (MEM) (with L-glutamate and without sodium bicarbonate) was obtained from Sigma in powder form. It was dissolved in the appropriate quantity of glass distilled water. Calcium chloride was added to give a final concentration of 1.25 mM. The solution was buffered with 10 mM NaHEPES and the pH adjusted to 7.2 using NaOH or HCl. 100 ml aliquots were stored at -20°C; in this form the medium is stable for several weeks. On the day of the experiment a suitable number of aliquots were thawed and defatted BSA (1% w/v) was added. The media was brought to a temperature of 37°C and the pH checked before use.

#### **2.9.1.2 Perfusion and cell dissociation**

Hearts from male Sprague-Dawley rats that had been starved overnight were removed, weighed and cannulated as described

in section 2.3.3. The hearts were perfused with nominally calcium-free Krebs-Ringer bicarbonate buffer (composition as described in section 2.3.1. except that calcium chloride was omitted) equilibrated with O<sub>2</sub>/CO<sub>2</sub> (95%/5%) at 37°C. The hearts were first perfused without recirculation for 5 minutes to wash out blood and calcium. They were then recirculation perfused in the presence of 20 μM CaCl<sub>2</sub>, 70mg/100ml collagenase and 30mg/100ml hyaluronidase, the final volume of perfusion medium being 50ml. After 15 minutes calcium was gradually reintroduced into the perfusion medium. This was done by adding calcium chloride from a stock solution so that the concentration in the perfusion medium increased in a step-wise manner to 0.6 mM in 5 equal stages over 5 minutes (ie a concentration rise of 0.12 mM per minute). After a further 10 minutes of perfusion (ie 30 minutes after addition of collagenase), the heart was removed from the cannula and placed in a plastic culture dish along with the perfusion medium. The atria were removed and the ventricles cut into small pieces using scissors. The pieces of ventricle were then placed in a closed plastic container along with the 50 ml of perfusion medium containing collagenase, equilibrated with O<sub>2</sub>/CO<sub>2</sub> (95%/5%) through a tube inserted into the top of the container and incubated at 37°C in a shaking water bath for 45-60 minutes. The exact incubation time depended on the extent of digestion of the tissue which was estimated when the heart was removed from the cannula. If the heart felt very soft to the touch the tissue was well digested and was

therefore given no more than 45 minutes incubation in order to avoid over-digestion. To obtain a high yield of cells it was usually necessary to perfuse two hearts simultaneously and pool the resulting cell suspensions prior to the 37°C incubation.

#### **2.9.1.3 Cell purification**

The resulting cell suspension was titrated gently 5-6 times using a 5 ml Gilson pipette and filtered through a double layer of 250  $\mu$ m butter muslin into 50 ml Sorvall polypropylene centrifuge tubes. The suspension was then centrifuged at 22 x g for 2 minutes using a bench top swinging bucket centrifuge (MSE minor S) and the supernatant, which contained collagenase, dead cells and other tissue debris, was discarded. The cells were then washed two or three times by resuspending the pellet in 5 ml of bicarbonate-free Joklik MEM and then centrifuging at 22 x g for 2 minutes and discarding the supernatant. The cells were finally resuspended in 2 ml of Joklik MEM and examined for yield and viability.

#### **2.9.1.4 Determination of yield and viability**

Cells were first examined morphologically under a microscope using a haemocytometer and viable cells

identified by the dye exclusion technique. A 10  $\mu$ l aliquot of the cell suspension was mixed with 5  $\mu$ l of 0.4% Trypan Blue solution and allowed to stand for two minutes. A sample of the mixture was then examined under a microscope at x 400 magnification. Three types of cell morphology could be identified. Calcium-tolerant viable cells appeared elongated with striations clearly visible and were not stained by the dye. These cells tended to clump together in groups. Dead cells appeared spherical in shape and were blue, having lost membrane integrity and therefore taken up the dye. A third morphology represented an intermediate state, appearing spherical but clear of dye. These were cells that were dying, having contracted but not yet become permeable to the dye. The number of cells in each category were counted and the cell yield expressed both as the number of viable (rod-shaped) cells per ml of suspension and as a percentage of the total number of cells. If the cell yield was lower than 60% the washing procedure was repeated once or twice in an attempt to remove dead cells. If a yield of 60% or more could not be obtained or if the number of viable cells per ml was too low (less than about 150,000) the suspension was discarded. Cells were then resuspended to give a final count of about 200,000 cells/ml. Viability of cells was also assessed biochemically by measuring the adenine nucleotide content and ATP/ADP ratio. This was done as part of each experiment by incubating time control aliquots of the cell suspension as described in section 2.9.2. If the ATP/ADP ratio of the

time-controls was less than 4.0, or if the ATP content decreased by more than 25% during the course of the experiment, the results were discarded.

### 2.9.2 Incubation of myocytes

The cell suspension was divided into equal aliquots of 400-600  $\mu$ l depending on the original volume and the number of aliquots required. Each aliquot was placed in a 20 ml glass vial that had been siliconised with Repelcote to prevent the cells sticking to the glass, and incubated at 37°C in a shaking water bath. The time controls were incubated aerobically for the appropriate period before the incubation was stopped and the tissue extracted as described in section 2.9.3. Anoxia was induced by closing the jar with a rubber stopper and gassing with O<sub>2</sub>-free nitrogen through a needle inserted through the stopper. Reoxygenation was achieved by removing the stopper so that the cells were once again exposed to the air. Drugs or other substances were added from a concentrated solution made up in Joklik MEM, the volume added being kept to a minimum to avoid diluting the cells too much, although to compensate for this a control aliquot had a similar amount of Joklik MEM, without drug, added at the same time.



### 2.9.3 Extraction of tissue and measurement of purines

At the end of its incubation period, each aliquot was quickly cooled to well below freezing by placing the bottom of the jar in liquid nitrogen for five seconds. An aqueous solution of 20% w/v trichloroacetic acid (TCA) and 50% v/v methanol (cooled to -10°C) was then added in a volume equal to that of the original aliquot to give a final concentration of 10% TCA and 25% methanol. The tissue suspension was then homogenised at -10°C using a glass rod and by shaking and the soluble and insoluble fractions separated by centrifugation in a Sorvall refrigerated centrifuge (Sorvall RC 5B Du Pont Instruments), at 17,000 (SM 24 rotor 9,000 x g ) for 5 minutes at 4°C. The supernatant was then treated to an ether wash as described in section 2.6. and the neutralised extract stored at -70°C before being analysed for purine nucleotides and metabolites using HPLC as described in section 2.7. This method of extraction results in the mixing of the intra- and extracellular contents because the addition of the TCA/methanol disrupts the cell membrane. However, it has been shown that under these conditions all the nucleotides measured can be assumed to have been present in the cells as these substances cannot easily cross the cell membrane and any that are released from dying cells would be quickly hydrolysed (Piper et al., 1982).

## CHAPTER 3 HEART PERFUSIONS - RESULTS AND DISCUSSION

Rat hearts were perfused by the Langendorff technique with the objective of firstly, studying and comparing the effect of ischaemia and reperfusion on adenine and guanine nucleotides and secondly, establishing conditions under which GTP concentrations were consistently changed so that the effect of these changes on GTP-dependent processes could be investigated.

### 3.1 Conditions of perfusion and normalisation of data

Hearts were perfused as described in section 2.3., subjected to various periods of global no-flow ischaemia and reperfusion and then freeze-clamped, homogenised and extracted (section 2.6), and the soluble extract assayed for purine nucleotides and nucleosides (sections 2.7 and 2.8). The data have been expressed per gram wet tissue in order to normalise the data from hearts of different size. Hearts were weighed before perfusion so that any apparent changes in the nucleotide content per g wet tissue cannot have resulted from changes in the water content of the heart during perfusion (Opie, 1965).

Each day of perfusions or extractions involved the same

number of hearts from each protocol where possible, so that any unaccounted for day to day variations in conditions would be less likely to bias the results.

Seasonal variations in the absolute content of nucleotides from perfused rat hearts have been observed (Bates, 1978), and may reflect variations in conditions in the animal house during the year (eg temperature, number of animals per cage), or may be related to changes in photo-period. It was therefore ensured that, for each particular experiment (ie series of perfusions), all hearts were from the same batch of rats and all were perfused within a few days of each other. Also, where the data have been combined from more than one series of perfusions, each value is expressed as a percentage of the corresponding control value to compensate for any seasonal or inter-batch variations.

### **3.2 Effect of ischaemia on purine nucleotides (series 1)**

Hearts were perfused at a pressure of 70 cm H<sub>2</sub>O and subjected to either 10 or 20 minutes of global no-flow ischaemia followed, in some cases, by a 10 minute period of reperfusion, using the method described in section 2.3.3. The results are shown in tables 3.1 to 3.4 and figures 3.1 to 3.3.

### 3.2.1 Effect of ischaemia on adenine nucleotides and breakdown products

The effect of ischaemia and reperfusion on adenine nucleotides was examined first to see whether the response of these hearts was consistent with previous studies. Table 3.1 and figure 3.1. show the effect of ischaemia and reperfusion on adenine nucleotide concentrations. The pre-ischaemic (control) concentration of ATP of 2.2  $\mu\text{mole/g}$  wet wt was lower than comparable previous studies, which show typical values of 2.5-3.5  $\mu\text{mole/g}$  wet wt (Bates et al., 1978; Mowbray et al., 1984), and was equivalent to an intracellular concentration of about 4.5 mM, using a conversion factor of 0.506 ml  $\text{H}_2\text{O/g}$  wet weight of tissue (Mowbray and Ottaway, 1973). In this first series of perfusions incorrect blotting technique and/or not removing all the excess fatty tissue before weighing the heart may have artificially increased its weight, thereby apparently decreasing concentrations. However, discrepancies in ATP concentrations of this kind between different batches of hearts perfused at different times of year, but under otherwise identical experimental conditions, have been noticed before (Bates, 1978), (see section 3.1.), and are also evident in results presented in section 3.3.

Following 20 minutes of ischaemia the ATP concentration fell significantly to about 38% of its pre-ischaemic (control) value ( $P < 0.0025$ ), and then returned to the

control value after a subsequent 10 minutes of reperfusion. ADP concentrations showed a rise during ischaemia such that after both 10 and 20 minutes, concentrations were about 2-fold higher than controls ( $P < 0.005$ ). Following reperfusion for 10 minutes in each case concentrations returned to control values. AMP showed a significant rise after 20 minutes of ischaemia ( $P < 0.05$ ), and returned to control values after 10 minutes of reperfusion. There was no significant change in the total adenine nucleotide concentration during the experiment. The recovery of ATP concentration on reperfusing for 10 minutes after 20 minutes of ischaemia was accounted for by corresponding decreases in the concentrations of ADP and AMP.

There is an apparent discrepancy in the adenine nucleotide changes during the first 10 minutes of ischaemia, because the rise in ADP occurred before there was any significant breakdown of ATP. However, because the absolute amount of ADP was small compared to ATP, the change in total adenine nucleotide content over this period was not statistically significant. Discrepancies in the content of total adenine nucleotides and breakdown products during and after ischaemia have been noted before and have led to the discovery of oligophosphoglyceroly-ATP, which may act as store or buffer to help regulate adenine nucleotide or free phosphate content and/or ratios at times of stress (Mowbray and Patel, 1991).

Legend to tables 3.1 and 3.2 and figures 3.1 and 3.2.  
(series 1)

All hearts were perfused at a pressure of 70 cm H<sub>2</sub>O with recirculation for 20 minutes. At the end of this period (designated t = 0), control hearts were freeze-clamped while experimental hearts were subjected to 10 or 20 minutes of global no-flow ischaemia (shown as solid line in figures) followed, in some cases, by 10 minutes of reperfusion (shown as broken line in figures) before being freeze-clamped.

Data shown as mean ± standard error of 4 or 5 hearts except where indicated.

Test of significance was by t-test.

\* = significantly different from control (zero-time)  
value p < 0.05.

# = significantly different from corresponding ischaemic  
value p < 0.05.

$$\text{Energy charge} = \frac{([\text{ATP}] + 1/2[\text{ADP}])}{([\text{ATP}] + [\text{ADP}] + [\text{AMP}])} \quad (\text{Atkinson, 1971})$$

**Table 3.1** *Effect of ischaemia and reperfusion on adenine nucleotides in isolated perfused rat hearts (series 1)*

nmole/g wet wt.

| <u>Protocol</u>            | ATP           | ADP          | AMP               | Total AN     | ATP/ADP       | Energy charge         |
|----------------------------|---------------|--------------|-------------------|--------------|---------------|-----------------------|
| control                    | 2169<br>±217  | 497<br>±57   | 143<br>±10        | 2809<br>±278 | 4.4<br>±0.2   | 0.86<br>-             |
| 10 min isch                | 1905<br>±204  | 1030*<br>±37 | 246<br>±58<br>n=3 | 3181<br>±244 | 1.6*<br>±0.2  | 0.76*<br>±0.03<br>n=3 |
| 10 min isch<br>+10 min rep | 1688<br>±188  | 491#<br>±37  | 247<br>±58        | 2426<br>±254 | 3.4*#<br>±0.2 | 0.80*<br>±0.01        |
| 20 min isch                | 836*<br>±129  | 897*<br>±55  | 649*<br>±131      | 2383<br>±211 | 0.9*<br>±0.1  | 0.55*<br>±0.04        |
| 20 min isch<br>+10 min rep | 1955#<br>±157 | 465#<br>±31  | 148<br>±28<br>n=2 | 2569<br>±186 | 4.2#<br>±0.2  | 0.85#<br>±0.01<br>n=2 |

**Table 3.2** *Effect of ischaemia and reperfusion on IMP, adenosine and inosine in isolated perfused rat hearts (series 1)*

nmole/g wet wt.

| <u>Protocol</u>            | IMP      | ADO         | INO                | Total AN +<br>IMP+ADO+INO |
|----------------------------|----------|-------------|--------------------|---------------------------|
| control                    | 27<br>±1 | 51<br>±6    | 43<br>±21          | 2929<br>±266              |
| 10 min isch                | 30<br>±3 | 102<br>±24  | 157*<br>±34<br>n=3 | 3470<br>±253              |
| 10 min isch<br>+10 min rep | 30<br>±4 | 94<br>±19   | 106*<br>±6         | 2655<br>±269              |
| 20 min isch                | 32<br>±3 | 244*<br>±38 | 379*<br>±13        | 3037<br>±241              |
| 20 min isch<br>+10 min rep | 32<br>±2 | 52#<br>±10  | 58#<br>±13<br>n=3  | 2710<br>±197              |



Figure 3.1 *Effect of ischaemia and reperfusion on adenine nucleotides in isolated perfused rat hearts (series 1)*

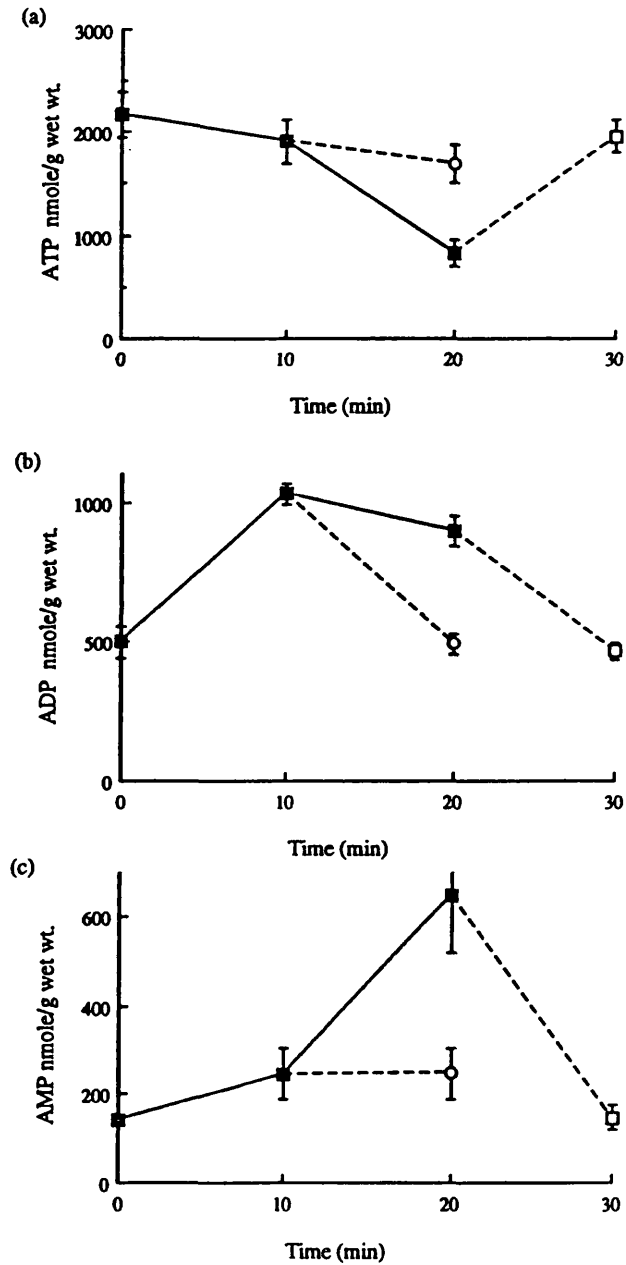

**Figure 3.2** *Effect of ischaemia and reperfusion on total adenine nucleotides and ATP/ADP ratio in isolated perfused rat hearts (series 1)*

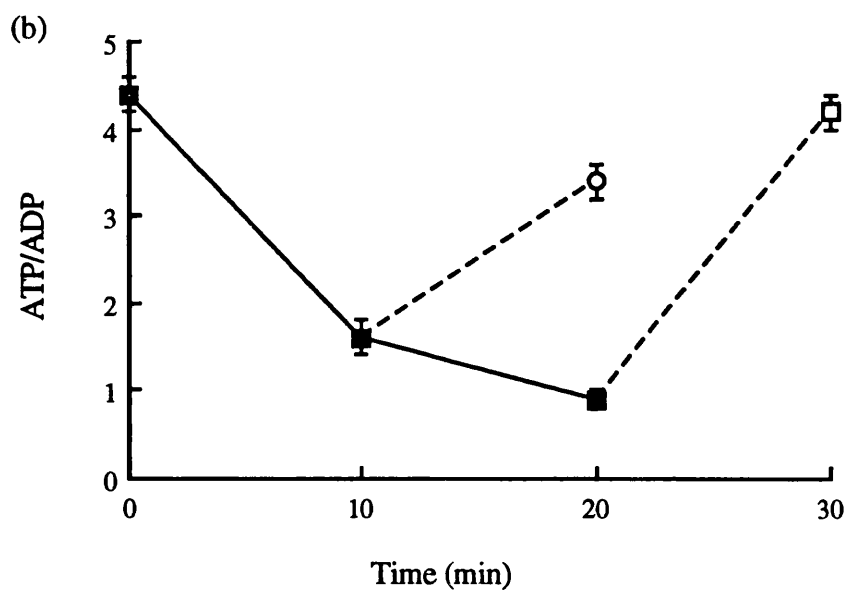
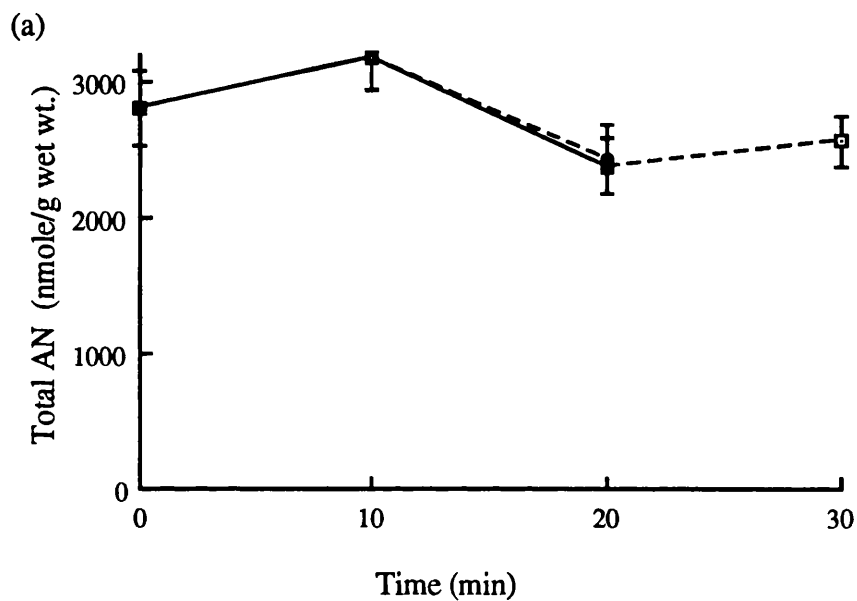

The ATP/ADP ratio and energy charge showed a significant fall after 10 and 20 minutes of ischaemia ( $P < 0.001$ ). The fall in the ATP/ADP ratio at 10 minutes was due to the rise in ADP, while that at 20 minutes was due to both increased ADP and reduced ATP concentrations. Reperfusion for 10 minutes following 20 minutes of ischaemia resulted in a recovery of both the ATP/ADP ratio and the energy charge to control values. However, reperfusion for 10 minutes after only 10 minutes of ischaemia resulted in only partial recovery of the ratio and energy charge ( $P < 0.05$ ). The control ratio of ATP/ADP of 4.4 is too low to act as a driving force for the unidirectional flow of metabolism (Atkinson, 1971), suggesting that much of the ADP is bound. The concentration of total ADP in these hearts was about 1.0mM. The concentration of free ADP in aerobic Langendorff perfused rat hearts has been calculated from n.m.r. studies using the creatine kinase equilibrium method to be about 20 $\mu$ M (eg. Kohn et al., 1977; Veech et al., 1979), or more recently in dog hearts *in vivo* as 55 $\mu$ M (Katz et al., 1989) suggesting that the actual free ATP/ADP ratio is about 20 to 50-fold higher.

The ischaemia-induced fall in ATP and rise in ADP and AMP seen here are broadly consistent with results by other workers (see Jennings and Steenbergen, 1985), although the full recovery of ATP on reperfusion is less commonly seen and appears to be more sensitive to the experimental conditions. Langendorff perfused rat hearts subjected to

global no-flow ischaemia for 30 minutes showed a 50 % fall in ATP concentration and a two-fold rise in AMP concentration, while a subsequent 30 minutes of reperfusion resulted in only partial recovery of the ATP concentration, although AMP concentrations returned to normal (Van Bilsen et al., 1989). Similar ischaemia-induced changes have been shown in the open-chested dog, where 12 minutes of regional ischaemia resulted in a fall in ATP concentration to 57% of the control value, while the concentrations of ADP and AMP both increased (Swain et al., 1982a).

The fall in ATP and rise in ADP and AMP concentrations during ischaemia are due to impaired oxidative phosphorylation of ADP, and although the utilisation of ATP falls as the hearts stop beating, other vital ATP-dependent processes such as maintenance of the plasma membrane ionic gradients continue to operate, resulting in gradual depletion of ATP and accumulation of breakdown products (Vary et al., 1979). Some synthesis of ATP occurs by anaerobic glycolysis but the rate is less than 10% of the rate of oxidative phosphorylation necessary to sustain cardiac function (Kobayashi and Neely, 1979; Vary et al., 1981), and results in the buildup of lactate which has a damaging effect (Katz and Hecht, 1969). The initial rise in ADP during ischaemia is followed by a rise in AMP owing to conversion of ADP to ATP and AMP by adenylate kinase (Reimer and Jennings, 1981).

Hearts stopped beating within two minutes of the onset of ischaemia, whereas ATP concentrations had not fallen significantly even after 10 minutes of ischaemia. Work on isolated rat hearts has shown that the cessation of mechanical function following ischaemia precedes any significant fall in whole cell ATP concentration (Neely et al., 1973), and is therefore due to other factors. Possible candidates have included compartmentation of ATP (Gudbjarnason et al., 1971;), reduced pH (Katz and Hecht, 1969), increased inorganic phosphate (Kammermeier et al., 1982) or buildup of extracellular potassium (Weiss and Shine, 1981; Kleber, 1983). Latest evidence suggests that a rise in inorganic phosphate is the most likely initial cause, as the time course for the other changes are too slow to account for the rapid deterioration of mechanical function during ischaemia (Allen and Orchard, 1987).

The effect of ischaemia and reperfusion on the adenine nucleotide breakdown products IMP, adenosine and inosine is shown in table 3.2. IMP concentrations remained constant at about 30 nmole/g wet wt under all conditions. Adenosine concentrations showed a significant rise after 20 minutes of ischaemia ( $P < 0.005$ ), and a return to control value after a subsequent 10 minutes of reperfusion. The values for adenosine after 10 minutes of ischaemia and after a subsequent 10 minutes of reperfusion were not significantly different from controls. Inosine concentrations showed a significant progressive rise during ischaemia reaching a

value of about 9-fold greater than controls after 20 minutes ( $P < 0.001$ ). Reperfusion for 10 minutes after 20 minutes of ischaemia resulted in a return to control values, while reperfusion for 10 minutes after only 10 minutes of ischaemia resulted in values still significantly higher than controls ( $P < 0.05$ ), despite the fact that the concentration of inosine at the start of this reperfusion was considerably lower than after 20 minutes of ischaemia. The reason for this is not clear. It may be that during reperfusion after 10 minutes of ischaemia, greater functional recovery occurs than after 20 minutes ischaemia and this results in continuing breakdown of adenine nucleotides to inosine. Also, the large fall in ADP during this reperfusion period is not accounted for by corresponding increases in either ATP or AMP (fig 3.1), and it may be that it is breaking down, via AMP, to inosine.

The rise in content of adenosine and inosine during ischaemia, while that of IMP remained unchanged, supports previous work which suggests that the major pathway of AMP breakdown in heart is initial dephosphorylation by 5'-nucleotidase to form adenosine, followed by deamination by adenosine deaminase, rather than the alternative pathway via IMP (Berne et al., 1971; Swain et al., 1982a) (see figure 1.1).

The large fall in ATP concentration after 20 minutes of ischaemia was balanced by the rises in concentration of

ADP, AMP, adenosine and inosine. The recovery of ATP on reperfusion could be accounted for by decreases in ADP, AMP and adenosine. The decrease in inosine content was probably mostly due to it being washed out of the heart rather than reincorporated into the adenine nucleotide pool, as the rate of washout has been shown to exceed the rate of reincorporation (Liu and Feinberg, 1971).

A comparison of the effect of different periods of ischaemia on the subsequent perfusion-induced recovery of adenine nucleotides is interesting. It seems that, contrary to what might be expected, both the extent and rate of recovery was greater after 20 minutes of ischaemia than after only 10 minutes. It can be seen from tables 3.1 and 3.2 that, although hearts after 20 minutes of ischaemia were in a "worse" position (as indicated by the ATP/ADP ratio, energy charge and the content of ATP and inosine) than those at 10 minutes of ischaemia, reperfusion resulted in a full recovery of the ATP/ADP ratio in the former hearts but only partial recovery in the latter. It is well known that the extent of post-ischaemic myocardial functional recovery is related to the duration of ischaemia (Humphrey et al., 1985). Therefore, one explanation for the apparent greater reperfusion-induced recovery of the ATP/ADP ratio after 20 minutes of ischaemia is that while some recovery of oxidative phosphorylation occurs in both cases, a greater impairment of functional recovery after 20 minutes of ischaemia results in a lower rate of ATP usage

than after 10 minutes of ischaemia. Although hearts were observed to resume beating within 2-3 minutes of reperfusion in each case, their actual mechanical performance was not measured, so it was not possible to establish whether such a difference in functional recovery had occurred.

### 3.2.2 Effect of ischaemia on guanine nucleotides

The effect of ischaemia and reperfusion on GTP and GDP concentrations is shown in table 3.3 and figure 3.3 (GMP was below the level of detection). The pre-ischaemic (control) concentration of GTP of about 150 nmole/g wet wt agrees with previous published results (Bates et al., 1978; Harmsen et al., 1984), and is equivalent to an intracellular concentration of approximately 300  $\mu$ M (using a conversion factor of 0.506ml H<sub>2</sub>O/g wet wt) (Mowbray and Ottaway, 1973). The concentration of GTP showed no significant change after 10 minutes of ischaemia, nor following a subsequent 10 minutes of reperfusion. However, following 20 minutes of ischaemia, the GTP concentration fell significantly to about 32% of the control value ( $P < 0.0005$ ), and returned to the control value after a subsequent 10 minutes of reperfusion. GDP concentrations showed no significant changes during the experiment, except that the concentrations on reperfusion following 10 minutes ischaemia were significantly lower than controls ( $P <$



0.05). Total guanine nucleotides showed a similar pattern of change as GTP.

These results show that the percentage changes to GTP during both ischaemia and the subsequent reperfusion are similar to those of ATP. However, the behaviour of guanine nucleotides differed from that of adenine nucleotides in two respects. Firstly, GDP (unlike ADP) showed no rise to coincide with the breakdown of GTP after 20 minutes of ischaemia. Secondly, further guanine nucleotide breakdown products (GMP, guanosine and guanine) were not detected under any of the conditions studied. Nor was there any buildup of XMP, which could be formed by deamination of GMP. If the constant value for GDP was due to it breaking down at the same rate as it was being formed by GTP hydrolysis, a buildup of GMP and/or guanosine would be expected to occur. Of course guanosine, like adenosine and inosine, is non-phosphorylated and therefore easily diffuses across the cell membrane, and would therefore be washed out of the heart on reperfusion. However, this would not explain the lack of evidence of any detectable accumulation of guanosine after 20 minutes of ischaemia, before any such washout could occur. Therefore the fall in GTP concentration after 20 minutes of ischaemia and its recovery on subsequent reperfusion could not be balanced by corresponding changes to its breakdown products.

Legend to tables 3.3 and 3.4 and figure 3.3 (series 1)

All hearts were perfused at a pressure of 70 cm H<sub>2</sub>O with recirculation for 20 minutes. At the end of this period (designated t = 0), control hearts were freeze-clamped while experimental hearts were subjected to 10 or 20 minutes of global no-flow ischaemia (shown as solid line in figures) followed, in some cases, by 10 minutes of reperfusion (shown as broken line in figures) before being freeze-clamped.

Data shown as mean  $\pm$  standard error of 4 or 5 hearts except where indicated.

Test of significance was by t-test.

In table 3.3:-

\* = significantly different from control (zero-time)  
value p < 0.05.

# = significantly different from corresponding ischaemic  
value p < 0.05.

Data in table 3.4 is the correlation coefficient calculated as described in section 2.2.

\* = significant correlation p < 0.05.

**Table 3.3** *Effect of ischaemia and reperfusion on guanine nucleotides in isolated perfused rat hearts (series 1)*

nmoles/g wet wt.

| <u>Protocol</u>            | GTP         | GDP       | Total GN    | GTP/GDP      |
|----------------------------|-------------|-----------|-------------|--------------|
| control                    | 154<br>±15  | 30<br>±1  | 184<br>±15  | 5.2<br>±0.6  |
| 10 min isch                | 112<br>±26  | 22<br>±4  | 134<br>±27  | 5.4<br>±1.6  |
| 10 min isch<br>+10 min rep | 120<br>±16  | 16*<br>±5 | 136<br>±16  | 10.0<br>±2.7 |
| 20 min isch                | 50*<br>±7   | 33<br>±4  | 83*<br>±5   | 1.6*<br>±0.3 |
| 20 min isch<br>+10 min rep | 126#<br>±26 | 31<br>±3  | 157#<br>±28 | 4.4#<br>±0.7 |

**Table 3.4** *Correlation between ATP and GTP concentrations and nucleotide ratios in isolated perfused rat hearts (series 1)*

| <u>Protocol</u>            | ATP & GTP | ATP/ADP & GTP/GDP |
|----------------------------|-----------|-------------------|
| control                    | 0.763     | -0.693            |
| 10 min isch                | 0.624     | -0.194            |
| 10 min isch<br>+10 min rep | 0.855     | 0.142             |
| 20 min isch                | 0.054     | 0.138             |
| 20 min isch<br>+10 min rep | 0.978*    | 0.346             |

Figure 3.3 *Effect of ischaemia and reperfusion on guanine nucleotides in isolated perfused rat hearts (series 1)*

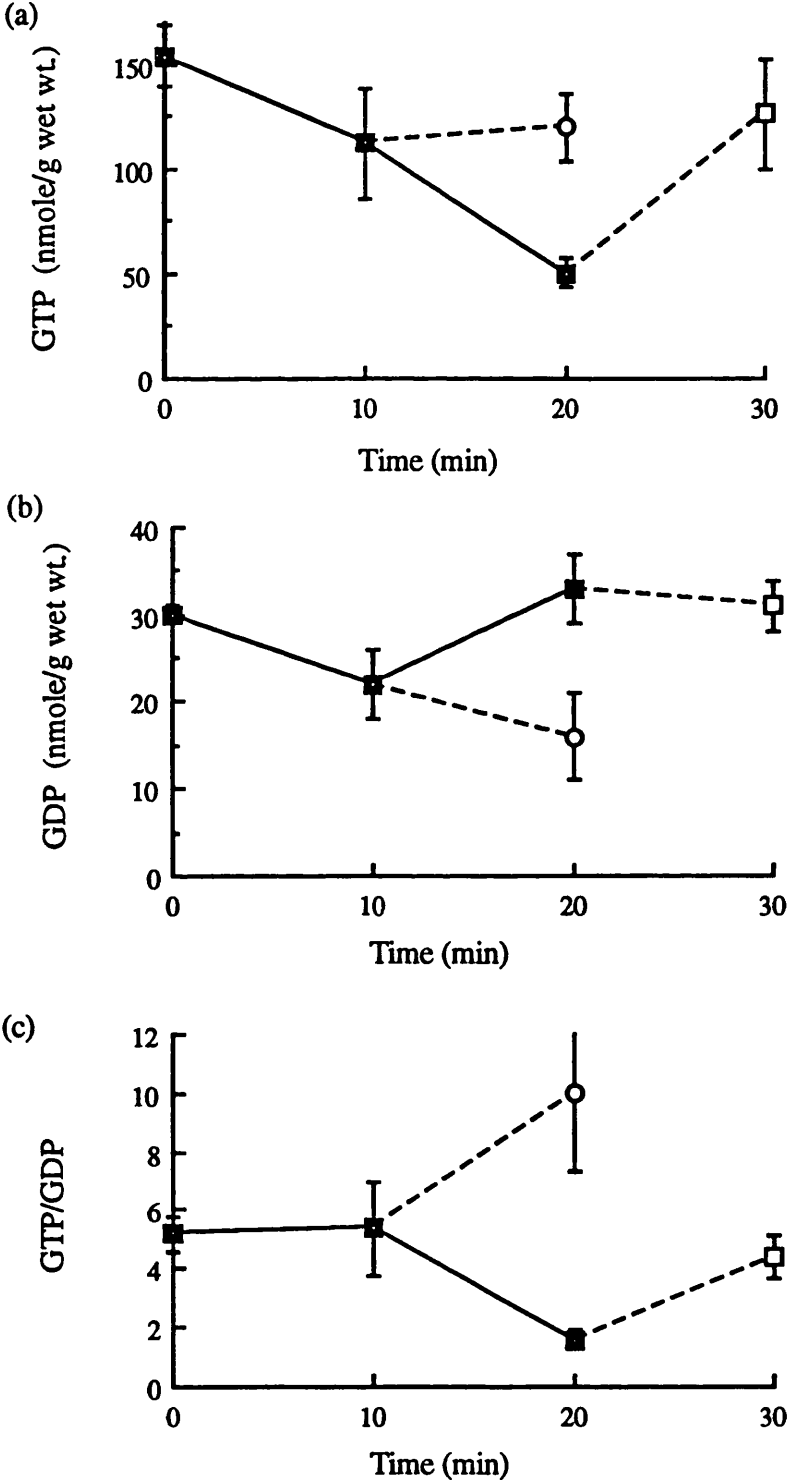

It is true that the measurement of guanine nucleotide breakdown products using HPLC is less accurate than measuring the corresponding adenine nucleotide products due to their much lower (15-20 fold) concentration and the fact that background noise will therefore have a proportionately greater effect. However, the system used (see section 2.7.1.) could detect concentrations down to about 5 nmole/g wet wt. reasonably accurately. Therefore, even if the breakdown products were present at just below this level, they would not account for the changes seen in GTP concentrations, which amounted to 75-100 nmole/g wet wt. It could be that any guanosine or guanine formed was metabolised to xanthine during the period of ischaemia. However, this would still not explain the source of the GTP recovery as the production of xanthine is an essentially irreversible step. One possibility for the source of GTP recovery on post-ischaemic reperfusion is synthesis from the existing adenine nucleotide pool via IMP and XMP (see figure 1.1 and section 1.3), and this was investigated in later experiments (see section 3.6).

In the case of hearts subjected to 20 minutes ischaemia and also those given subsequent reperfusion, the GTP/GDP ratio broadly matched the ATP/ADP ratio, showing a significant fall during ischaemia ( $P < 0.005$ ) and a recovery on reperfusion. Hearts subjected to only 10 minutes of ischaemia showed no change in the GTP/GDP ratio. On subsequent reperfusion a fall in the GDP concentration

caused an apparent rise in the ratio, although this was found not to be statistically significant.

The correlation coefficients between ATP and GTP concentrations and ATP/ADP and GTP/GDP ratios for each subset of hearts are shown in table 3.4. The positive correlation between the ATP and GTP concentrations was significant only in the case of 20 minutes ischaemia plus reperfusion, indicating that those hearts which showed a lower than average ATP recovery also showed a lower than average GTP recovery.

Correlation between the ATP/ADP and GTP/GDP ratios within each subset of hearts was low. Coupling between the ATP/ADP and GTP/GDP ratios is mediated by nucleoside diphosphate kinase, so that at equilibrium the GTP/GDP ratio will be proportional to the ATP/ADP ratio, and decoupling will occur if the reaction departs from equilibrium following inhibition of the enzyme. The low correlation between the ATP/ADP and GTP/GDP ratios in these hearts suggests that the nucleoside diphosphate kinase reaction may not be at equilibrium, although much of the ADP (and possibly GDP) is bound (Kohn et al., 1977), so the ratios measured will not reflect the ratio of free nucleotides in the cell. However, as discussed in section 1.3.3.2., previous studies on perfused rat hearts in this laboratory (Mowbray et al., 1984) suggest that under certain conditions this reaction is not at equilibrium and therefore the state of

phosphorylation of adenine and guanine nucleotide pools can be regulated independently. If this is the case following ischaemia, it might be that the reperfusion-induced recovery of the GTP/GDP ratio could lag behind the recovery of the ATP/ADP ratio, and this was examined in later experiments (see sections 3.3 and 3.4).

### 3.3 Effect of ischaemia and increased workload on purine nucleotides (series 2)

The results in the previous section showed that, in Langendorff perfused rat hearts, the magnitude and timecourse of ischaemia-induced changes in GTP concentration mirrored those of ATP, and 10 minutes of reperfusion following 20 minutes of global no-flow ischaemia was sufficient to restore the GTP concentration to its pre-ischaemic value. In an attempt to find conditions under which the guanine nucleotide content or ratio was consistently reduced relative to that of adenine nucleotides, it was decided to subject hearts to increased stress by increasing their workload. Hearts (with atria removed) were therefore perfused at an increased pressure (130 cm H<sub>2</sub>O), and were paced at 4 cycles per second, 250 mV, by inserting electrodes into the apex of the heart, as described in section 2.3.3. The tissue was then extracted and analysed as described in sections 2.6 and 2.7.

The set of hearts perfused in this way (series 2) were subjected to 20 minutes of global no-flow ischaemia followed by 10 minutes of reperfusion, so that the results could be directly compared to the corresponding times for the non-working hearts described above (series 1). The results for series 2 are shown in tables 3.5 to 3.8 and figures 3.4 and 3.5. As discussed above, seasonal and inter-batch variations mean that it is not possible to compare the absolute content of nucleotides with that of the series 1 hearts, although it is noticeable that the pre-ischaemic content of all purine nucleotides and nucleosides was considerably higher in series 2 hearts.

### **3.3.1 Effect of ischaemia and workload on adenine nucleotides and breakdown products**

The effect of ischaemia and reperfusion on adenine nucleotides is shown in table 3.5 and figure 3.4. The pre-ischaemic (control) concentration of ATP was 3.5  $\mu\text{mole/g}$  wet wt., (about 7 mM). Following 20 minutes of ischaemia the ATP concentration fell significantly to about 31% of its control value ( $P < 0.0005$ ), which was a slightly greater fall than that observed in the series 1 hearts (38%). On reperfusion for 10 minutes the ATP showed a significant rise ( $P < 0.02$ ), but was still significantly lower than the control ( $P < 0.025$ ). Therefore, in contrast to series 1 hearts, 10 minutes of reperfusion was not



sufficient to restore ATP concentrations to control values. Concentrations of ADP after 20 minutes of ischaemia and after reperfusion were not significantly different from control, although there may have been a transient rise in the early stages of ischaemia. The concentration of AMP showed a significant rise after 20 minutes of ischaemia ( $P < 0.005$ ), and a return to the control value on reperfusion. The almost five-fold rise in AMP was similar to that seen after 20 minutes ischaemia in series 1 hearts. Total adenine nucleotides showed a significant fall after 20 minutes of ischaemia ( $P < 0.05$ ), and on reperfusion no further change occurred. There was thus a net loss of adenine nucleotides over the course of the experiment of about 30%, which was not seen in the series 1 hearts. The loss in adenine nucleotides after 20 minutes ischaemia was balanced by rises in adenosine and inosine (Table 3.6), while the partial recovery of ATP on reperfusion was accounted for by a fall in the AMP content. Table 3.6 also shows that IMP did not appear to change ( $n=2$ ) throughout the regime.

Changes to the ATP/ADP ratio and the energy charge were similar to those seen in series 1 hearts; falling significantly after 20 minutes of ischaemia ( $P < 0.001$ ), and returning to the control value after 10 minutes of reperfusion. This recovery occurred despite the fact that ATP concentrations showed only partial recovery, and was due to lower (but not statistically significant) ADP and

AMP content after reperfusion.

These results are consistent with previous studies on hearts from both rats and other species. Similar falls in ATP and rises in AMP have been reported in isolated working rat hearts subjected to 20 minutes of low-flow ischaemia (50% reduction in flow) (Neely et al., 1973), and in dog hearts subjected to severe ischaemia *in vivo* for 15 minutes (Jennings et al., 1981). Other studies with rat hearts have showed a less rapid depletion of ATP, but this may be because the hearts were subjected to less workload (Van Bilsen et al., 1989), or to low-flow ischaemia rather than no-flow ischaemia (Harmsen et al., 1984). The partial recovery of ATP on reperfusion and the net depletion of adenine nucleotides following ischaemia have been shown in perfused rat hearts (Harmsen et al., 1984; Van Bilsen et al., 1989), and following brief ischaemia in the open-chested dog (Swain et al., 1982a), and are thought to contribute to the long-term functional impairment seen after ischaemia. The use of non-aqueous tissue fractionation studies suggest that the reduced post-ischaemic ATP concentration is mostly due to a reduction in the cytosolic concentration. Thus, 15 minutes of reperfusion following 20 minutes of ischaemia in perfused working rat hearts resulted in complete recovery of mitochondrial ATP concentrations, while the cytosolic concentration was only about one-half of its pre-ischaemic value (Humphrey et al., 1990).

Legend to tables 3.5 and 3.6 and figure 3.4 (series 2).

All hearts had their atria removed and were perfused at a pressure of 130 cm H<sub>2</sub>O and electrically paced at 250 mv, 4 cycles per second. Hearts were initially perfused with recirculation for 20 minutes. At the end of this period (designated t = 0), control hearts were freeze-clamped while experimental hearts were subjected to 20 minutes of global no-flow ischaemia followed, in some cases, by 10 minutes of reperfusion before freeze-clamping.

Data shown as mean ± standard error of 4 or 5 hearts except where indicated.

Test of significance was by t-test.

\* = significantly different from control (zero-time)  
value p < 0.05.

# = significantly different from ischaemic value  
p < 0.05.

**Table 3.5** *Effect of ischaemia and reperfusion with increased workload on adenine nucleotides in isolated perfused rat hearts (series 2)*

nmole/g wet wt.

| <u>Protocol</u>            | ATP                   | ADP               | AMP                 | Total AN             | ATP/ADP             | Energy charge         |
|----------------------------|-----------------------|-------------------|---------------------|----------------------|---------------------|-----------------------|
| control                    | 3439<br>±211          | 702<br>±22        | 384<br>±166<br>n=3  | 4526<br>±157         | 4.9<br>±0.3         | 0.83<br>±0.05<br>n=3  |
| 20 min isch                | 1058*<br>±201         | 617<br>±52        | 1869*<br>±116       | 3544*<br>±270        | 1.7*<br>±0.3        | 0.38*<br>±0.04        |
| 20 min isch<br>+10 min rep | 2337*#<br>±201<br>n=3 | 509<br>±43<br>n=3 | 294#<br>±232<br>n=3 | 3141*<br>±258<br>n=3 | 4.6#<br>±0.5<br>n=3 | 0.83#<br>±0.07<br>n=3 |

**Table 3.6** *Effect of ischaemia and reperfusion with increased workload on IMP, adenosine and inosine in isolated perfused rat hearts (series 2)*

nmole/g wet wt.

| <u>Protocol</u>            | IMP              | ADO               | INO                | Total AN +<br>IMP+ADO+INO |
|----------------------------|------------------|-------------------|--------------------|---------------------------|
| control                    | 70<br>±13        | 130<br>±22        | 198<br>±73         | 4931<br>±132              |
| 20 min isch                | 111<br>±8<br>n=2 | 317*<br>±35       | 805*<br>±46        | 4834<br>±320              |
| 20 min isch<br>+10 min rep | 67<br>±18<br>n=2 | 142<br>±55<br>n=3 | 225#<br>±83<br>n=3 | 3637*<br>±308<br>n=3      |

**Figure 3.4** *Effect of ischaemia and reperfusion with increased workload on adenine nucleotides in isolated perfused rat hearts (series 2)*

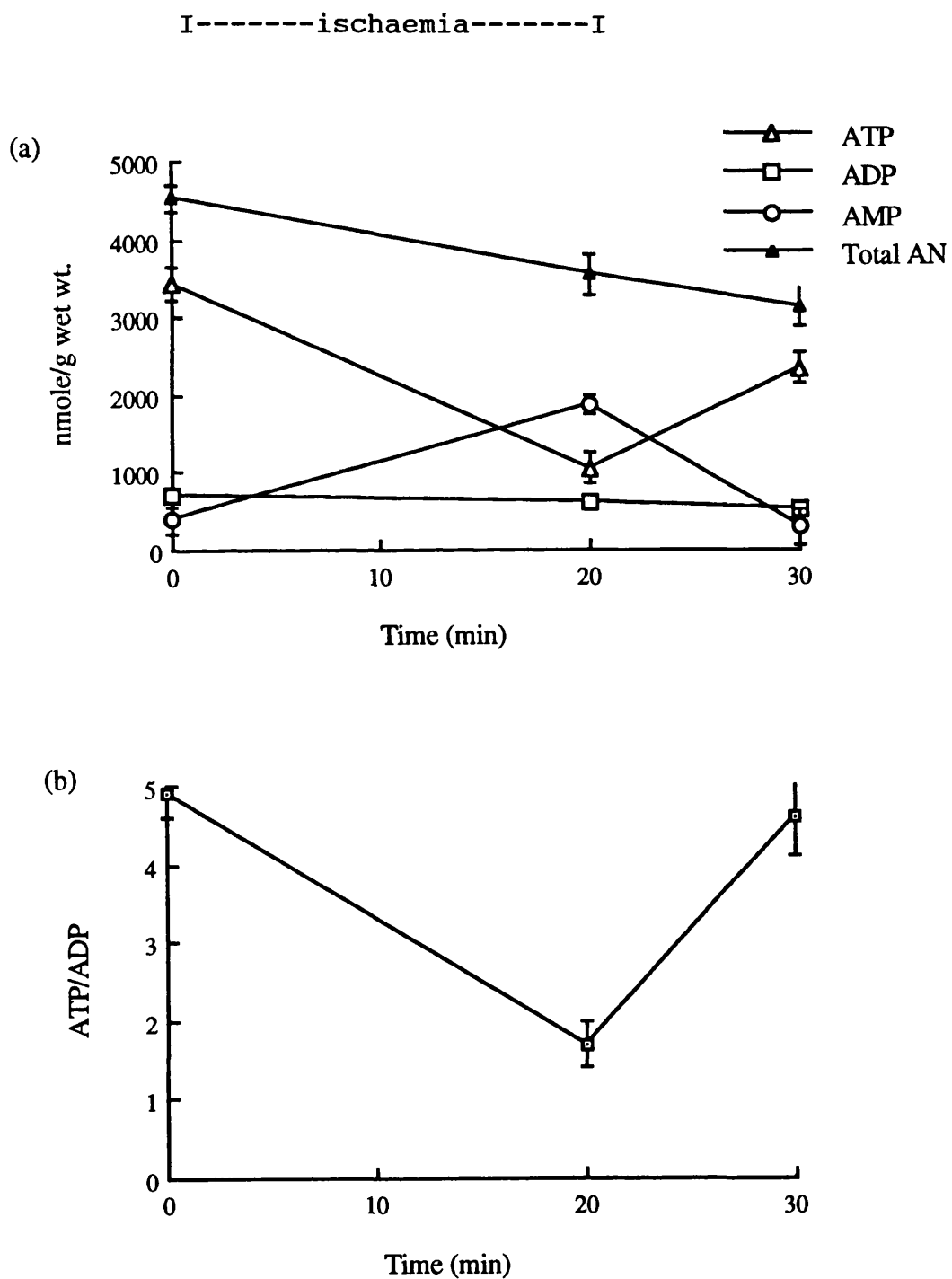

### 3.3.2 Effect of ischaemia and workload on guanine nucleotides

The effect of ischaemia and reperfusion on guanine nucleotides is shown in table 3.7 and figure 3.5. The mean control value for GTP was 275 nmole/g wet wt., (about 550  $\mu$ M). Ischaemia for 20 minutes resulted in a significant fall of GTP to 41% of the control value ( $P < 0.01$ ), while reperfusion for 10 minutes resulted in complete recovery. This is in contrast to the behaviour of ATP which showed only partial recovery on reperfusion. Concentrations of GDP showed no significant changes. As in the previous set of hearts neither GMP nor guanosine were detected, so the changes to GTP were not balanced by corresponding changes to its breakdown products. Although total guanine nucleotides (GTP + GDP) showed a significant fall after 20 minutes ischaemia ( $P < 0.01$ ), full recovery occurred on reperfusion. Therefore, unlike adenine nucleotides, no net depletion of guanine nucleotides had occurred by the end of the reperfusion period.

Previous work on the effects of ischaemia on GTP suggests that there is a long-term depletion of guanine nucleotides similar to that seen for adenine nucleotides. Reperfusion following 12 minutes of regional cardiac ischaemia in open-chested dogs resulted in some recovery of ATP and GTP but full recovery had still not occurred 24 hours after the onset of reperfusion, unless the hearts were treated with

a purine precursor (Swain et al., 1982b); although the conditions in that study were considerably different from those of the isolated rat heart. However, measurements of the rates of incorporation of [<sup>14</sup>C]-labelled hypoxanthine into ATP and GTP in working perfused rat hearts following ischaemia, suggest that the post-ischaemic recovery of GTP is faster than that of ATP (Harmsen et al., 1984). This would agree with the results of the series 2 perfusions, in which the post-ischaemic recovery of GTP was complete while that of ATP was partial.

The GTP/GDP ratio closely resembled the ATP/ADP ratio, showing a significant fall after 20 minutes ischaemia ( $P < 0.01$ ), and a return to the control value on reperfusion (figure 3.5); a pattern similar to that seen in the series 1 hearts. It therefore appears that the recovery of the GTP/GDP ratio parallels that of the ATP/ADP ratio, suggesting that the nucleoside diphosphate kinase reaction is close to equilibrium. This is further supported by the positive correlation seen between these ratios within each subset of hearts (Table 3.8), although these are not statistically significant due to the small n values.

Legend to tables 3.7 and 3.8 and figure 3.5 (series 2).

All hearts had their atria removed and were perfused at a pressure of 130 cm H<sub>2</sub>O and electrically paced at 250 mv, 4 cycles per second. Hearts were initially perfused with recirculation for 20 minutes. At the end of this period (designated t = 0), control hearts were freeze-clamped while experimental hearts were subjected to 20 minutes of global no-flow ischaemia followed, in some cases, by 10 minutes of reperfusion before freeze-clamping.

Data shown as mean  $\pm$  standard error of 4 or 5 hearts except where indicated.

Test of significance was by t-test.

\* = significantly different from control (zero-time)  
value  $p < 0.05$ .

# = significantly different from ischaemic value  
 $p < 0.05$ .

Data in table 3.8 is the correlation coefficient calculated as described in section 2.2.



**Table 3.7** *Effect of ischaemia and reperfusion with increased workload on guanine nucleotides in isolated perfused rat hearts (series 2)*

nmoles/g wet wt.

| <u>Protocol</u>            | GTP                | GDP              | Total GN          | GTP/GDP             |
|----------------------------|--------------------|------------------|-------------------|---------------------|
| control                    | 275<br>±20         | 60<br>±3         | 335<br>±19        | 4.7<br>±0.5         |
| 20 min isch                | 113*<br>±7         | 77<br>±4         | 190*<br>±5        | 1.6*<br>±0.3        |
| 20 min isch<br>+10 min rep | 229#<br>±37<br>n=3 | 47<br>±14<br>n=3 | 276<br>±50<br>n=3 | 5.3#<br>±1.0<br>n=3 |

**Table 3.8** *Correlation between ATP and GTP concentrations and nucleotide ratios in isolated perfused rat hearts subjected to increased workload (series 2)*

| <u>Protocol</u>            | ATP & GTP    | ATP/ADP & GTP/GDP |
|----------------------------|--------------|-------------------|
| control                    | -0.251       | 0.636             |
| 20 min isch                | 0.584        | 0.778             |
| 20 min isch<br>+10 min rep | 0.514<br>n=3 | 0.871<br>n=3      |

**Figure 3.5** *Effect of ischaemia and reperfusion with increased workload on guanine nucleotides in isolated perfused rat hearts (series 2)*

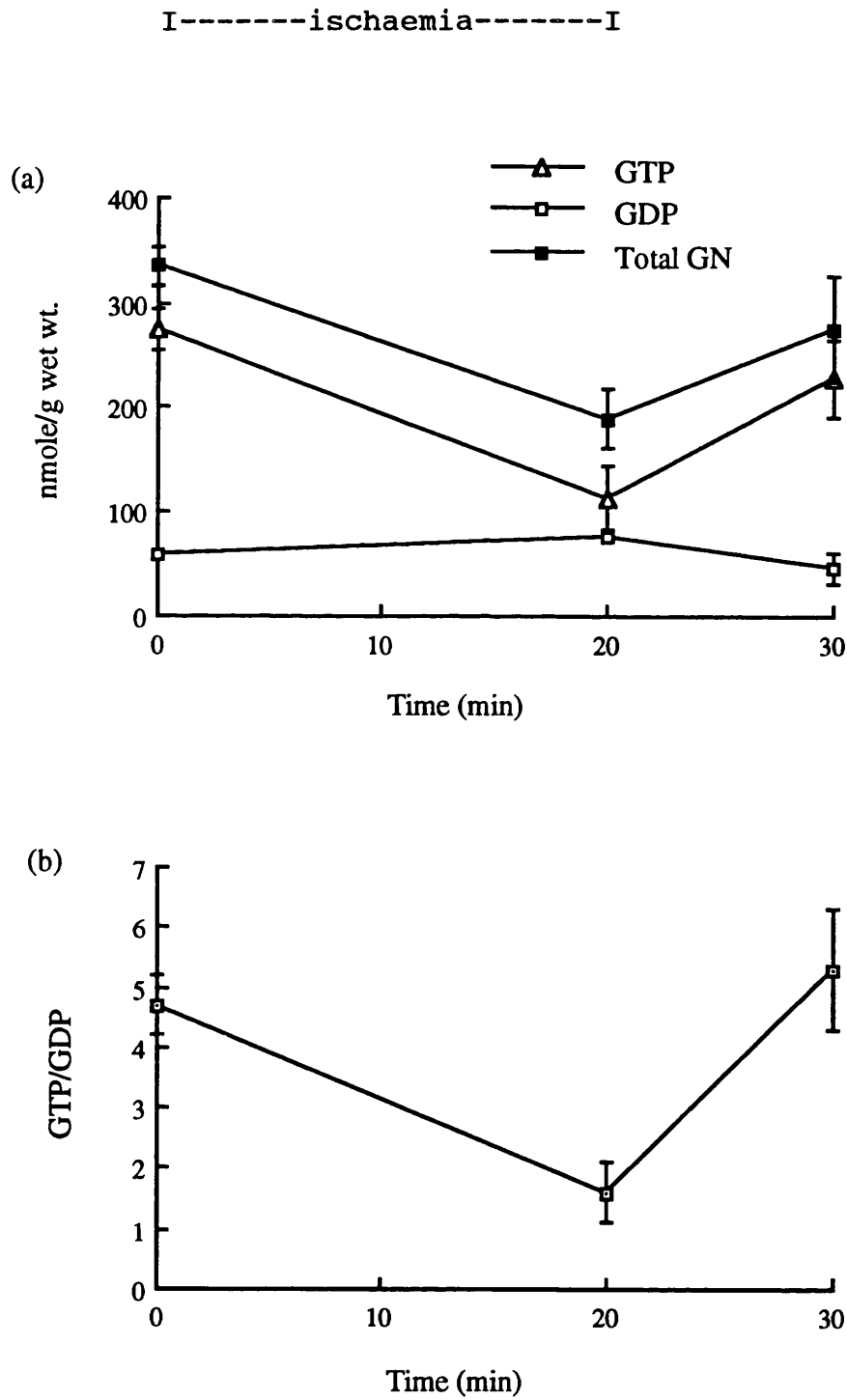

### **3.4 Effect of longer-term ischaemia and reperfusion on purine nucleotides (series 3, 4 and 5)**

It was decided to perform a series of time course experiments on working hearts to determine firstly, the effect of longer periods of ischaemia on guanine nucleotide concentrations and secondly, whether longer periods of reperfusion following 20 minutes of ischaemia would result in greater recovery of ATP and whether the apparent full recovery of GTP shown by series 2 would be sustained. All hearts were perfused at a pressure of 130 cm H<sub>2</sub>O and paced at 4 cycles per second, 250 mV, as before. In series 3, hearts were subjected to 20 minutes of global no-flow ischaemia and then reperfused for various periods up to 40 minutes. In series 4 and 5, hearts were subjected to increased periods of ischaemia up to 70 minutes, with those in series 5 being reperfused for 20 minutes.

#### **3.4.1 Effect of longer-term ischaemia on ATP, GTP and nucleotide ratios**

Figures 3.6. and 3.7. show a summary of all the time series data for ATP, GTP and the nucleotide ratios. Because this involved combining data from three series of perfusions, all figures are shown as a percentage of the corresponding control value. During the first 30 minutes of ischaemia there was a rapid fall in ATP concentration to about 10% of

the control value (figure 3.6a.). The rate of decrease then levelled off, so that by 70 minutes of ischaemia the concentration was about 5% of the control. At 45 minutes of ischaemia the ATP concentration was about 9% of the control, which compares with 35% reported by Van Bilsen et al., (1989), although the working conditions imposed in the latter study were less harsh. The extent of recovery on reperfusion became progressively lower the longer the period of ischaemia, so that in hearts subjected to 20 minutes ischaemia, complete recovery of ATP occurred after only 10 minutes of reperfusion, while after 70 minutes ischaemia only slight recovery occurred following 20 minutes reperfusion. These results agree with the results of Van Bilsen et al., (1989) in showing a successive reduction in perfusion-induced recovery of ATP after increasing periods of global no-flow ischaemia.

The changes to GTP concentrations (figure 3.7a) showed a similar pattern to those of ATP. There was a rapid fall during the first 30 minutes of ischaemia to a value about 20% that of the control, after which the rate of decrease levelled off. Like ATP, the extent of reperfusion-induced recovery of GTP showed progressive deterioration with increasing periods of ischaemia; complete recovery occurred on reperfusion for 10 minutes after 20 minutes of ischaemia, while there was very little recovery on reperfusion after 70 minutes ischaemia.

Legend to figures 3.6 and 3.7 (series 3, 4 and 5)

All hearts had their atria removed and were perfused at a pressure of 130 cm H<sub>2</sub>O and electrically paced at 250 mV, 4 cycles per second. Hearts were initially perfused with recirculation for 20 minutes. At the end of this period (designated t = 0), control hearts were freeze-clamped while experimental hearts were subjected to various periods of global no-flow ischaemia (solid line) followed, in some cases, by periods of reperfusion (broken lines) before freeze-clamping.

Each data point represents a single heart, except for the case of 20 minutes ischaemia with or without reperfusion, which represent an average of 3 or more hearts. Because the data were taken from three separate series of perfusions, all values are expressed as a percentage of the corresponding control value.

For series 3 the mean ATP and GTP content for control hearts was 2494 and 229 nmole/g wet wt. respectively.

**Figure 3.6** *Effect of various periods of ischaemia and reperfusion with increased workload on ATP content and ATP/ADP ratio in isolated perfused rat hearts (series 3, 4 and 5)*

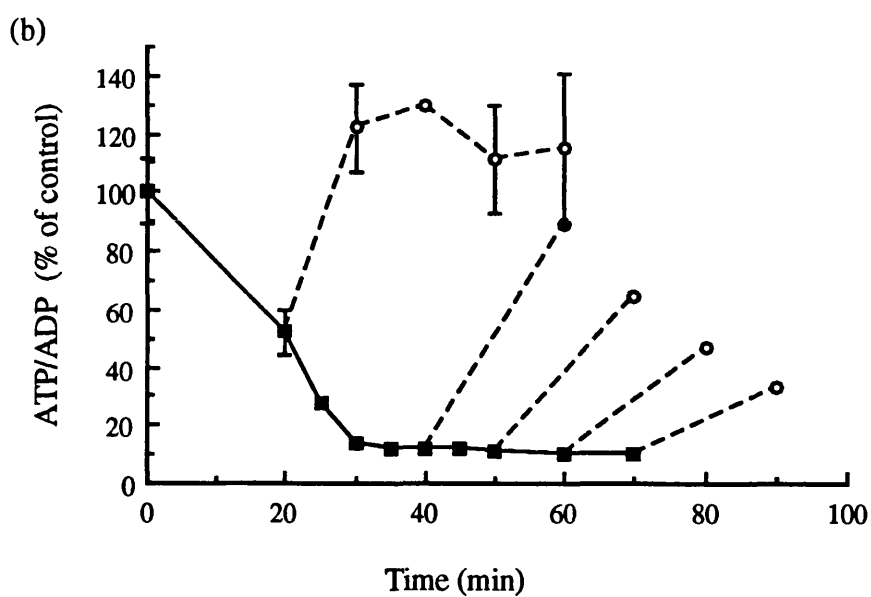
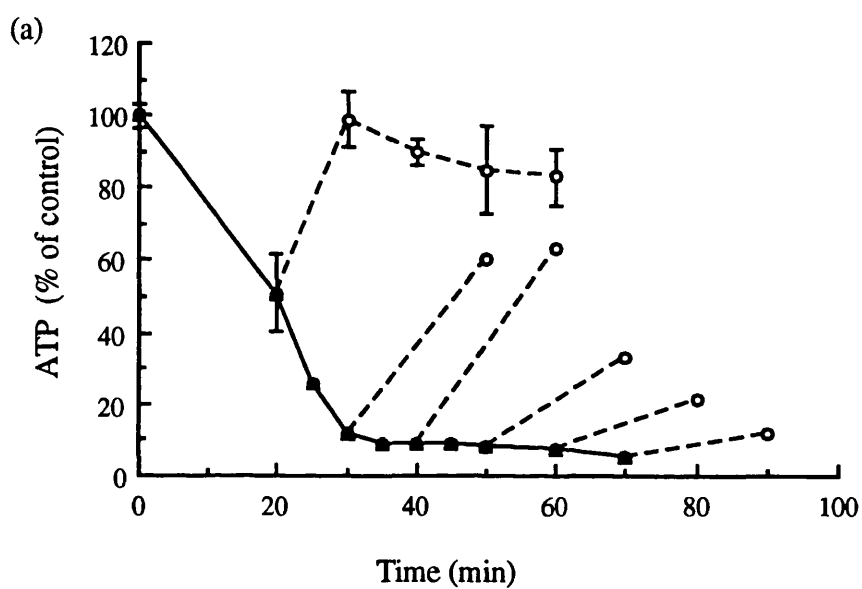

**Figure 3.7** *Effect of various periods of ischaemia and reperfusion with increased workload on GTP content and GTP/GDP ratio in isolated perfused rat hearts (series 3, 4 and 5)*

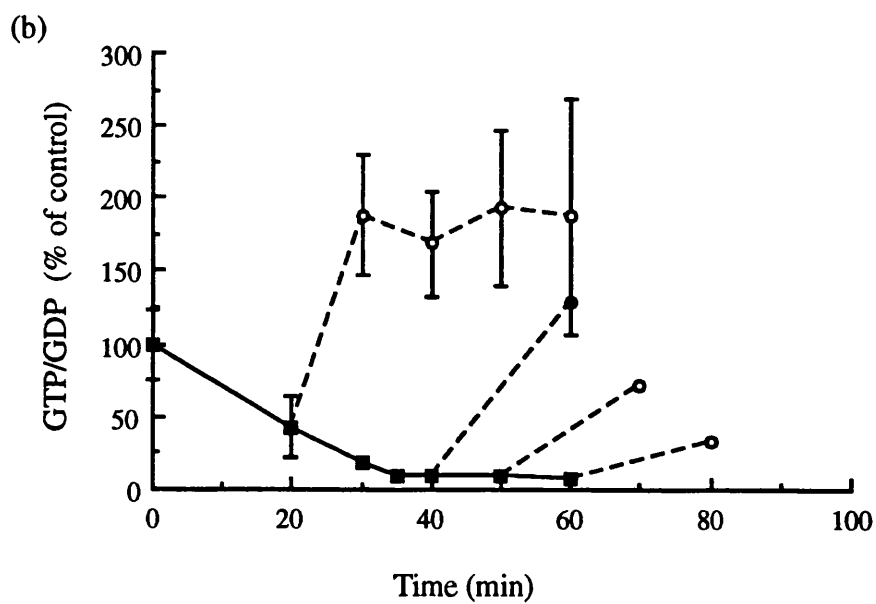
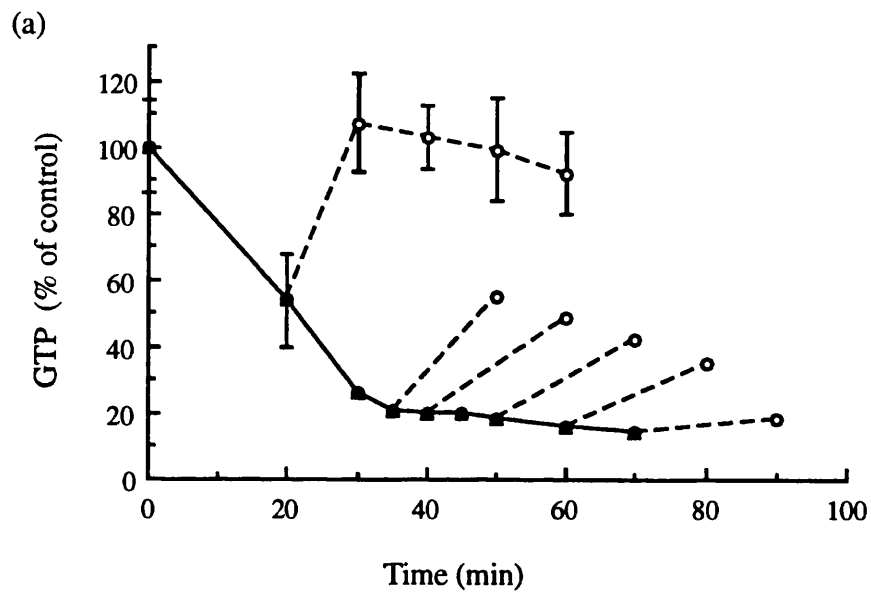

The changes to the ATP/ADP ratio (figure 3.6b) followed a similar pattern to that for ATP itself, showing a rapid fall to about 10% of the control value after 30 minutes of ischaemia and a progressive deterioration of reperfusion-induced recovery with increasing periods of ischaemia. However, a greater degree of recovery of the ATP/ADP ratio occurred compared with the ATP recovery for the same timepoint. This was due to a greater recovery of ATP relative to ADP for each timepoint. The effect of ischaemia on the GTP/GDP ratio was similar to that on the ATP/ADP ratio, with a rapid fall to about 10% of the control value by 30 minutes of ischaemia before levelling off (figure 3.7b). Like the ATP/ADP ratio, the reperfusion-induced recovery of the GTP/GDP ratio became progressively less with increasing periods of ischaemia. After shorter periods of ischaemia (20-40 minutes), percentage recovery was higher than for the ATP/ADP ratio, due to a fall in the concentration of GDP on reperfusion. This caused an apparent rebound effect, with the ratio recovering to more than 100% of the control value, although due to the small n values this was not statistically significant. There was no evidence of any significant post-ischaemic inhibition of the nucleoside diphosphate kinase reaction.



### 3.4.2 Effect of longer periods of reperfusion on adenine nucleotides and breakdown products (series 3)

The complete data for the hearts subjected to 20 minutes ischaemia and various periods of reperfusion (series 3) are shown in tables 3.9 to 3.13. Part of the protocol for this series was identical to that for series 2 but there are a number of differences in the results. Firstly, the control value for ATP of 2.5  $\mu\text{mole/g}$  wet wt (about 5 mM) was significantly lower ( $P < 0.02$ ) than that for series 2 (3.4  $\mu\text{mole/g}$  wet wt). Secondly, the control ATP/ADP ratio of 2.7 was also significantly lower ( $P < 0.05$ ) than that for series 2, which was 4.9. Thirdly, 10 minutes of reperfusion following 20 minutes of ischaemia resulted in full recovery of ATP values in series 3, while only partial recovery occurred in series 2. The only way that the experiment for these two series differed was that series 2 were perfused over a two-week period in June 1990, while series 3 were perfused over a two-week period in September 1990 using, of course, a different batch of rats. The reason for the differences could therefore be seasonal or inter-batch variations as discussed in section 3.1. Another explanation is that the apparent temporal positions of the maxima and minima of the post-ischaemic synchronous fluctuations previously observed in this laboratory tend to vary a little from one batch of perfusions to another (Bates et al., 1978), so that the ATP content measured in series 2

may have occurred near a maximum while that for series 3 occurred near a minimum.

The ATP concentration fell significantly to about 50% of the control value after 20 minutes of ischaemia ( $P < 0.005$ ), this being less of a drop than for series 2. Reperfusion for 10 minutes resulted in complete recovery and no significant change occurred during the remaining 30 minutes of reperfusion (fig. 3.6a). The shape of the curve for ATP hints at a small decline with increasing reperfusion period, but none of the values are significantly different from the control. Concentrations of ADP at the various timepoints were not significantly different from control values, although the possibility that ADP concentrations increased transiently in the early stages of ischaemia cannot be excluded. Unlike series 2 there was no significant rise in AMP concentration after 20 minutes of ischaemia although, like ADP, a transient rise earlier in the ischaemic period could not be excluded. The concentration of AMP on reperfusion was not significantly different from the control value. The value following both 20 and 30 minutes of reperfusion was, however, significantly lower than that at 20 minutes of ischaemia ( $P < 0.05$ ). Total adenine nucleotides showed a significant fall ( $P < 0.05$ ) after 20 minutes of ischaemia, a result similar to that seen in series 2. The value following 20 minutes of reperfusion was also significantly lower than the control ( $P < 0.05$ ). Inosine concentrations showed a

Legend to tables 3.9 to 3.11 (series 3)

All hearts had their atria removed and were perfused at a pressure of 130 cm H<sub>2</sub>O and electrically paced at 250 mV, 4 cycles per second. Hearts were initially perfused with recirculation for 20 minutes. At the end of this period (designated t = 0), control hearts were freeze-clamped while experimental hearts were subjected to 20 minutes of global no-flow ischaemia followed, in some cases, by periods of reperfusion before freeze-clamping.

Data is expressed as mean  $\pm$  standard error of 3 or 4 hearts except where stated.

Test of significance was by t-test.

\* = significantly different from control (zero-time)  
value  $p < 0.05$ .

# = significantly different from ischaemic value  
 $p < 0.05$ .

**Table 3.9** *Effect of ischaemia and various periods of reperfusion with increased workload on adenine nucleotides in isolated perfused rat hearts (series 3)*

nmole/g wet wt.

| <u>Protocol</u>         | ATP                  | ADP                 | AMP                | Total AN              | ATP/ADP              | Energy charge          |
|-------------------------|----------------------|---------------------|--------------------|-----------------------|----------------------|------------------------|
| control                 | 2494<br>±82          | 930<br>±99          | 239<br>±105        | 3925<br>±239          | 2.7<br>±0.3          | 0.76<br>±0.02          |
| 20 min isch             | 1270*<br>±266        | 881<br>±126         | 762<br>±151<br>n=3 | 2856*<br>±450         | 1.4*<br>±0.2         | 0.61*<br>±0.05<br>n=3  |
| +10 min rep             | 2460#<br>±194        | 738<br>±40          | 261<br>±64         | 3459<br>±120          | 3.3#<br>±0.4         | 0.82#<br>±0.03         |
| +20 min rep             | 2251#<br>±90         | 654<br>±22          | 177#<br>±42        | 3080<br>±121          | 3.5#<br>-            | 0.84*<br>±0.01#        |
| +30 min rep             | 2117<br>±296         | 725<br>±95          | 177<br>±65<br>n=2  | 3020<br>±308          | 3.0#<br>±0.5         | 0.82#<br>±0.04<br>n=3  |
| +40 min rep             | 2081<br>±197         | 698<br>±111         | -                  | -                     | 3.1<br>±0.7          | -                      |
| Mean of all reperfusion | 2229#<br>±83<br>n=13 | 700*<br>±28<br>n=13 | 205#<br>±29<br>n=9 | 3176*<br>±107<br>n=10 | 3.2#<br>±0.2<br>n=13 | 0.82*<br>±0.01#<br>n=9 |

**Table 3.10** *Effect of ischaemia and various periods of reperfusion with increased workload on IMP, adenosine and inosine in isolated perfused rat hearts (series 3)*

nmole/g wet wt.

| <u>Protocol</u>            | IMP             | ADO                  | INO                  | Total AN<br>+IMP+ADO+INO |
|----------------------------|-----------------|----------------------|----------------------|--------------------------|
| control                    | 110<br>±31      | 287<br>±59           | 434<br>±41           | 4755<br>±233             |
| 20 min isch                | 109<br>-<br>n=1 | 379<br>±96           | 679*<br>±58          | 4023<br>±451             |
| +10 min rep                | 97<br>-<br>n=1  | 197<br>±79           | 313<br>±158          | 4066<br>±122             |
| +20 min rep                | 70<br>-<br>n=1  | 122<br>±21           | 184#<br>±75          | 3457<br>±189             |
| +30 min rep                | 63<br>-<br>n=1  | 113<br>±17           | 152*#<br>±34         | 3348<br>±273             |
| +40 min rep                | 87<br>-<br>n=1  | 124<br>±33<br>n=2    | 184#<br>±105<br>n=2  | -                        |
| Mean of all<br>reperfusion | 79<br>±9<br>n=4 | 139*#<br>±19<br>n=12 | 208*#<br>±42<br>n=12 | 3607*<br>±141<br>n=10    |

Table 3.11 Amount of inosine in the perfusate from rat hearts subjected to ischaemia and increased workload (series 3)

|  | nmoles/g wet wt. |
|--|------------------|
| pre-ischaemic (control)                        | 1879             |
| 20 mins ischaemia                              | 2792             |
| 20 min ischaemia +<br>reperfusion for:- 10 min | 2415             |
| 20 min   | 2796             |
| 30 min   | 1612             |
| 40 min   | 3493             |

Each figure represents the perfusate from one heart.

significant rise after 20 minutes of ischaemia ( $P < 0.05$ ) and on reperfusion returned to control values, except for the value after 30 minutes of reperfusion, which was significantly lower than the control ( $P < 0.02$ ). There were no significant changes to adenosine or IMP content during the regime. While the decrease in total adenine nucleotides following ischaemia was not balanced by a corresponding rise in breakdown products, the recovery of ATP during the first 10 minutes of reperfusion was balanced by decreases in the content of AMP and nucleosides.

The net loss of adenine nucleotides plus nucleosides after both 20 and 30 minutes of reperfusion compared with the control value ( $P < 0.01$  and  $0.025$  respectively) was probably due to the washout of nucleosides from the heart during reperfusion. Measurement of breakdown products in the perfusate confirmed that such a washout had occurred (see table 3.11.). Only inosine appeared to be present, and the average amount in the perfusate following reperfusion (about  $2.5 \mu\text{mole/g wet wt.}$ ) was a substantial fraction (about one-third) of the total purines present in the hearts. Even the control figure was high, one explanation being that the insertion of electrodes and the electrical pacing had caused some tissue damage, resulting in leakage and subsequent hydrolysis of purine nucleotides.

Both the ATP/ADP ratio and the energy charge showed significant falls following 20 minutes of ischaemia ( $P <$

0.025) and recovered after 10 minutes of reperfusion (table 3.9). Longer periods of reperfusion had no further effect on either except that the energy charge following 20 minutes of reperfusion was significantly higher than the control ( $p < 0.05$ ).

#### 3.4.3 Effect of longer periods of reperfusion on guanine nucleotides

The effect of longer periods of reperfusion on guanine nucleotides is shown in table 3.12 and figure 3.7. The control GTP concentration of 230 nmole/g wet wt (about 450  $\mu\text{M}$ ), was slightly less than that for series 2 (275 nmole/g wet wt.). The significant fall in GTP concentration after 20 minutes of ischaemia ( $P < 0.05$ ), and the recovery after 10 minutes reperfusion, were similar to the result for series 2. Longer periods of reperfusion had no significant effect on the GTP concentration, although like ATP there was a hint of a steady decline with time (figure 3.7a). GDP concentrations showed no significant difference from the control value. Owing to the large standard deviations, the fall in the GTP/GDP ratio after 20 minutes of ischaemia was not statistically significant. Likewise, the ratios following reperfusion were not significantly different from the control. However, the ratios after 10 and 20 minutes of reperfusion were significantly higher than the value after 20 minutes of ischaemia ( $P < 0.05$  in both cases). As for



**Table 3.12** *Effect of ischaemia and various periods of reperfusion with increased workload on guanine nucleotides in isolated perfused rat hearts (series 3)*

nmole/g wet wt.

| <u>Protocol</u>                 | GTP         | GDP        | Total GN    | GTP/GDP       |
|---------------------------------|-------------|------------|-------------|---------------|
| control                         | 229<br>±32  | 47<br>±15  | 275<br>±35  | 5.8<br>±1.4   |
| 20 min isch                     | 124*<br>±32 | 64<br>±21  | 188<br>±35  | 2.5<br>±1.2   |
| +10 min rep                     | 244<br>±34  | 23<br>±3   | 267<br>±33  | 10.9<br>±2.4  |
| +20 min rep                     | 236#<br>±22 | 26<br>±4   | 262<br>±19  | 9.8<br>±2.1   |
| +30 min rep                     | 226<br>±35  | 22<br>±6   | 248<br>±34  | 11.2<br>±3.1  |
| +40 min rep                     | 210<br>±28  | 24<br>±9   | 235<br>±19  | 10.9<br>±4.7  |
| Mean of all reperfusion<br>n=13 | 230#<br>±11 | 24*#<br>±2 | 254#<br>±10 | 10.6#<br>±1.2 |

Legend to tables 3.12 and 3.13 (series 3)

All hearts had their atria removed and were perfused at a pressure of 130 cm H<sub>2</sub>O and electrically paced at 250 mV, 4 cycles per second. Hearts were initially perfused with recirculation for 20 minutes. At the end of this period (designated t = 0), control hearts were freeze-clamped while experimental hearts were subjected to 20 minutes of global no-flow ischaemia followed, in some cases, by periods of reperfusion before freeze-clamping.

Data is expressed as mean ± standard error of 3 or 4 hearts except where stated.

Test of significance was by t-test.

In table 3.12:-

\* = significantly different from control (zero-time) value p < 0.05.

# = significantly different from ischaemic value p < 0.05.

Data in table 3.13 is the correlation coefficient calculated as described in section 2.2.

\* = significant correlation (p<0.05).

**Table 3.13** *Correlation between ATP and GTP concentrations and nucleotide ratios in isolated perfused rat hearts subjected to increased workload (series 3)*

| <u>Protocol</u>        | ATP & GTP | ATP/ADP & GTP/GDP |
|------------------------|-----------|-------------------|
| control                | 0.933     | -0.050            |
| 20 min ischaemia       | 0.122     | 0.612             |
| +10 min rep.           | 0.712     | -0.156            |
| +20 min rep.           | 0.788     | -0.276            |
| +30 min rep.           | 0.992     | 0.987             |
| +40 min rep.           | 0.949     | 0.991             |
| All 13<br>reperfusions | 0.840*    | 0.596*            |

previous series the changes to GTP concentrations were not balanced by corresponding changes to its breakdown products.

The correlation between ATP and GTP contents and the nucleotide ratios are shown in table 3.13. Because of the small n values, none of the correlations for individual subsets of hearts are statistically significant. However, because the means and standard deviations for the different periods of reperfusion were not significantly different from each other, correlations were calculated for all 13 reperfused hearts taken together. For these there was a statistically significant positive correlation for both the concentrations and ratios, suggesting that the nucleoside diphosphate kinase reaction was at or close to equilibrium.

Because some of the hearts in series 3 underwent the same protocol as those in series 2 (20 minutes ischaemia with or without 10 minutes reperfusion), it was decided to examine the correlations between adenine and guanine nucleotide content and ratios for these hearts in series 2 and 3 combined. The data are shown in table 3.14 and figures 3.8 and 3.9 and are expressed as a percentage of the control mean for each series, owing to a significant difference in the mean content of ATP and the ATP/ADP ratio between the two series (see section 3.4.2). None of the correlation coefficients were statistically significant at the 5% confidence level. However, it is interesting that the

Legend to table 3.14 and figures 3.8 and 3.9.

All hearts had their atria removed and were perfused at a pressure of 130 cm H<sub>2</sub>O and electrically paced at 250 mV, 4 cycles per second. Hearts were initially perfused with recirculation for 20 minutes. At the end of this period (designated t = 0), control hearts were freeze-clamped while experimental hearts were subjected to 20 minutes of global no-flow ischaemia followed, in some cases, by 10 minutes of reperfusion before freeze-clamping.

Each point represents data from one heart.

As the data are from two sets of perfusions, they are expressed as a percentage of the corresponding control mean.

Data in table 3.14 is the correlation coefficient calculated as described in section 2.2.

**Table 3.14** *Correlation between ATP and GTP concentrations and nucleotide ratios in isolated perfused rat hearts subjected to increased workload (series 2 and 3)*

| <u>Protocol</u>                  | ATP & GTP | ATP/ADP & GTP/GDP |
|----------------------------------|-----------|-------------------|
| control (n=9)                    | 0.1514    | 0.1471            |
| 20 min isch (n=8)                | 0.3917    | 0.5966            |
| 20 min isch<br>+10 min rep (n=6) | 0.7485    | 0.5514            |

**Figure 3.8** *Correlation of post-ischaemic ATP and GTP content of isolated perfused rat hearts subjected to increased workload (series 2 and 3)*

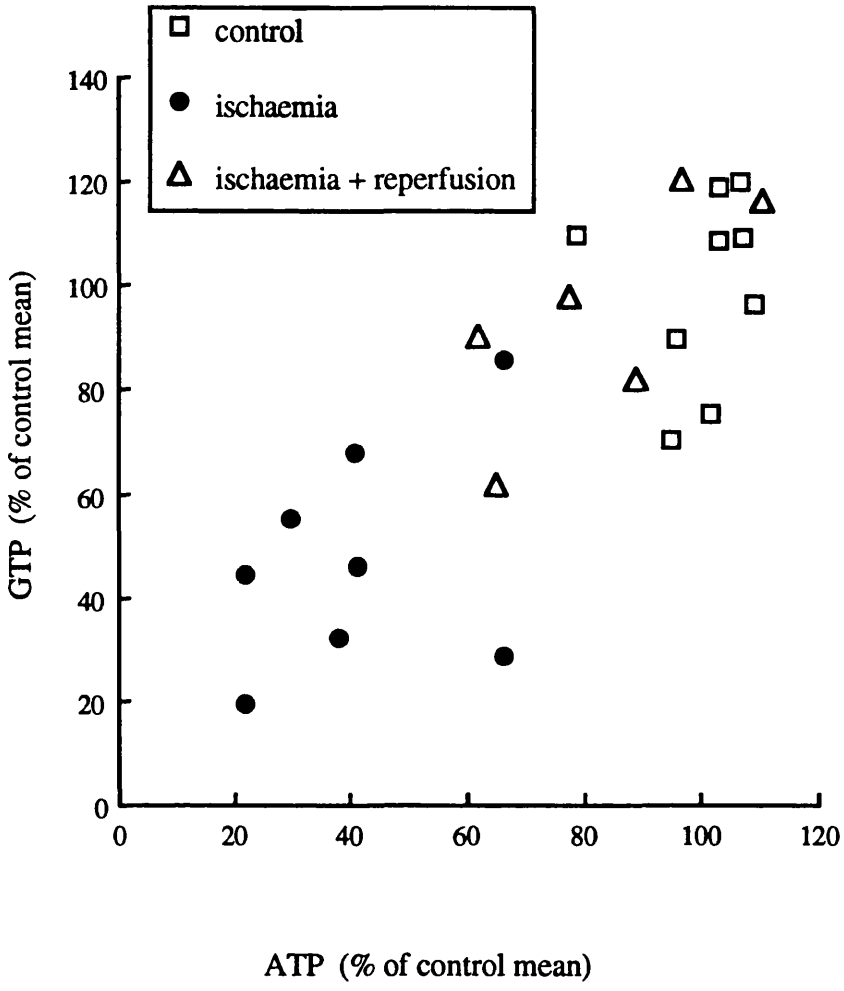

Figure 3.9 Correlation of post-ischaemic ATP/ADP and GTP/GDP ratio of isolated perfused rat hearts subjected to increased workload (series 2 and 3)

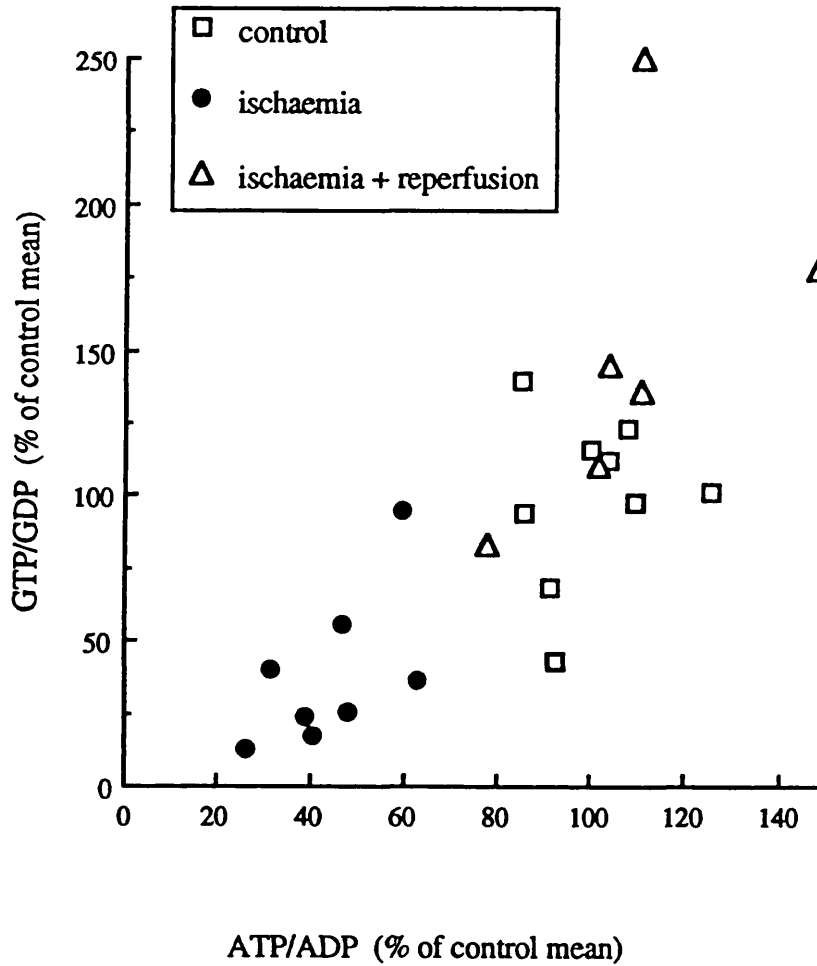

figure for the correlation between ATP and GTP following reperfusion was just below significance, hinting that the nucleoside diphosphate kinase reaction was at or close to equilibrium. This would agree with the results obtained when all 13 of the series 3 reperfusions were taken together (table 3.13).

#### **3.4.4 Summary of the effects of increased periods of ischaemia and reperfusion**

During longer periods of ischaemia changes in the concentrations of guanine nucleotides paralleled those of adenine nucleotides. For series 3 hearts, the reperfusion-induced recovery of both adenine and guanine nucleotide concentrations and ratios occurred within the first 10 minutes of reperfusion and longer periods of reperfusion (up to 40 minutes) did not result in any further significant changes. There was no evidence of guanine and adenine nucleotide concentrations being regulated independently. Nor was there any evidence of the synchronous post-ischaemic fluctuations in nucleotide content observed previously in this laboratory (Bates et al., 1978; Mowbray et al., 1981; 1984), although this may have been due to the different experimental conditions employed in the present study; ie increased workload and a longer period of ischaemia.

### 3.5 The source of post-ischaemic guanine nucleotide recovery

There are three known pathways by which the post-ischaemic recovery of guanine nucleotides could occur:-

1. Salvage of guanine nucleotide breakdown products.
2. *De novo* synthesis.
3. Synthesis from existing adenine nucleotide pool or salvage from adenine nucleotide breakdown products eg adenosine.

The above results suggest that salvage from guanosine or guanine is unlikely to play a major role in the recovery, as these compounds were not detected and were therefore not present in sufficient quantity at the start of the reperfusion period to account for the recovery of GTP. Furthermore, these substances, like adenosine and inosine, are likely to be washed out of the heart on reperfusion much faster than their rate of reincorporation into the guanine nucleotide pool. *De novo* synthesis is also an unlikely source as its rate is probably much too low. The post-ischaemic recovery of GTP in both series 2 and series 3 was about 80 nmole/g wet wt during 10 minutes of reperfusion; ie an average rate of 8 nmole/g wet wt/min. Although the rate of *de novo* synthesis of guanine nucleotides in heart has not been directly measured, the rate of *de novo* synthesis of adenine nucleotides in perfused rat heart during post-ischaemic recovery is about



0.15 nmole/min/g (Zimmer et al., 1973). Therefore, to account for GTP recovery, the *de novo* synthesis of guanine nucleotides would need to be some 50-fold higher than that for adenine nucleotides. This is not very plausible given that guanine nucleotides are present at a concentration some 15 to 20-fold lower than adenine nucleotides and that both types of nucleotide share a common *de novo* synthesis pathway up to IMP. The third possibility, synthesis from the adenine nucleotide pool or salvage from breakdown products such as adenosine, inosine or hypoxanthine, has some evidence to support it (see section 1.3.2). Working rat hearts subjected to low-flow ischaemia (70% reduction) and reperfused in the presence of 0.02mM [8-<sup>14</sup>C] hypoxanthine and 0.5 mM ribose showed an incorporation rate into GTP of 0.08 nmole/min/g (Harmsen et al., 1984). This is still far too low to account for the GTP recovery seen in series 2 and 3, although the conditions employed by Harmsen et al. may not have been suitable for inducing a high rate of guanine nucleotide synthesis.

All pathways of guanine nucleotide synthesis, apart from salvage of guanosine and guanine, involve the conversion of IMP to XMP by the enzyme IMP-dehydrogenase (see figure 1.1). IMP-dehydrogenase inhibitors were therefore used in an attempt to determine the extent to which this pathway contributes to post-ischaemic guanine nucleotide recovery.

### 3.6 Effect of IMP-dehydrogenase inhibitors on post-ischaemic recovery of guanine nucleotides (series 6, 7 and 8)

Working hearts were perfused as described in section 2.3.3., subjected to 20 minutes ischaemia and reperfusion in the presence or absence of various IMP-dehydrogenase inhibitors. The soluble extract was assayed for adenine and guanine nucleotides as described in sections 2.6 and 2.7. Three inhibitors were tested; mycophenolic acid, 6-mercaptopurine ribonucleotide and ribavirin.

#### 3.6.1 Mycophenolic acid (series 6)

Mycophenolic acid is an antibiotic substance produced by *Penicillium brevi-compactum*, *P. stoloniferum* and related species, and has been shown to almost completely inhibit GMP synthesis in human lymphoblasts at a concentration of 10  $\mu\text{M}$  (Willis and Seegmiller, 1979). Because it is only sparingly soluble in water, mycophenolic acid was administered as a solution in ethanol to give final concentrations of 100 or 400  $\mu\text{M}$ . The results of two experiments are shown in figure 3.10. In the case where 400  $\mu\text{M}$  inhibitor was used, BSA (1% w/v) was added to the perfusion medium to act as a carrier and enhance the delivery of the drug to the tissue. It can be seen that there was no significant difference to the post-reperfusion

total guanine nucleotide concentration, nor to the individual concentrations of GTP and GDP between those hearts receiving the drug and the controls. The concentrations of adenine nucleotides were also measured, lest any reduction in GTP concentration was a result of a reduction in ATP, rather than a direct effect of the drug. However, as expected there was no significant difference in adenine nucleotide concentrations between hearts receiving the drug and the controls. The lower concentrations of all nucleotides seen in the 400  $\mu$ M experiment can be attributed to the much higher concentration of ethanol used (1% v/v), or possibly to the presence of BSA, which caused frothing of the perfusion medium.

### 3.6.2 6-mercaptapurine ribonucleotide (6-MPR) (series 7)

This compound is an analogue of AMP and IMP. Being phosphorylated it is readily soluble in water but cannot cross cell membranes by diffusion. To enter the cell it would therefore need to be dephosphorylated by membrane bound exo-nucleotidases, or taken up by an active or facilitative transport mechanism. Its use as an anti-neoplastic agent suggests that such a mechanism for crossing the cell membrane exists. The results of two experiments using 6-MPR are shown in figure 3.11. There was no significant difference in total guanine nucleotide or

Legend to figure 3.10 (series 6)

All hearts had their atria removed and were perfused at a pressure of 130 cm H<sub>2</sub>O and electrically paced at 250 mV, 4 cycles per second. Hearts were initially perfused with recirculation for 20 minutes and were then subjected to 20 minutes of global no-flow ischaemia followed by 20 minutes of reperfusion. Mycophenolic acid (MPA) (dissolved in ethanol) was added to the perfusion medium 15 minutes before the onset of ischaemia. Control hearts received ethanol only. Concentration of ethanol was 0.1% v/v for 100  $\mu$ M MPA and 1% v/v for 400  $\mu$ M MPA. In addition, medium for the 400  $\mu$ M MPA experiment included BSA 1% w/v.

Data shown as mean  $\pm$  standard error of 5 and 3 hearts for the 100  $\mu$ M and 400  $\mu$ M experiment respectively.

Statistical analysis was by t-test.

Figure 3.10 Effect of mycophenolic acid on the post-ischaemic recovery of guanine nucleotides in isolated perfused rat hearts (series 6)

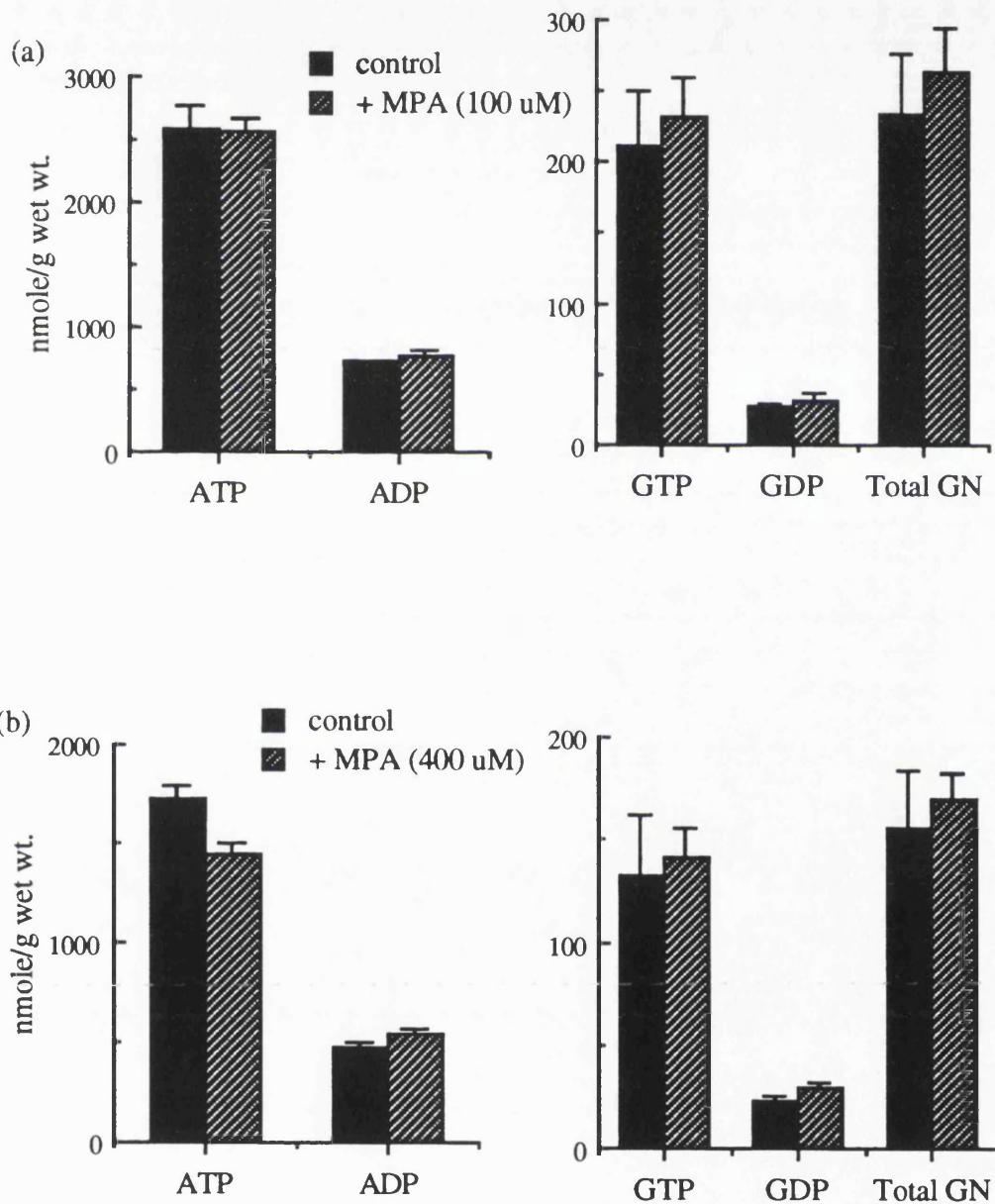

Legend to figure 3.11 (series 7)

All hearts had their atria removed and were perfused at a pressure of 130 cm H<sub>2</sub>O and electrically paced at 250 mV, 4 cycles per second. Hearts were initially perfused with recirculation for 20 minutes and were then subjected to 20 minutes of global no-flow ischaemia followed by 20 minutes of reperfusion. 6-mercaptopurine ribonucleotide (6-MPR) was added to the perfusion medium 15 minutes before the onset of ischaemia.

Data shown as mean  $\pm$  standard error of 4 or 5 hearts.

Statistical analysis was by t-test. \* = P < 0.05.

**Figure 3.11** *Effect of 6-mercaptapurineribonucleotide on the post-ischaemic recovery of guanine nucleotides in isolated perfused rat hearts (series 7)*

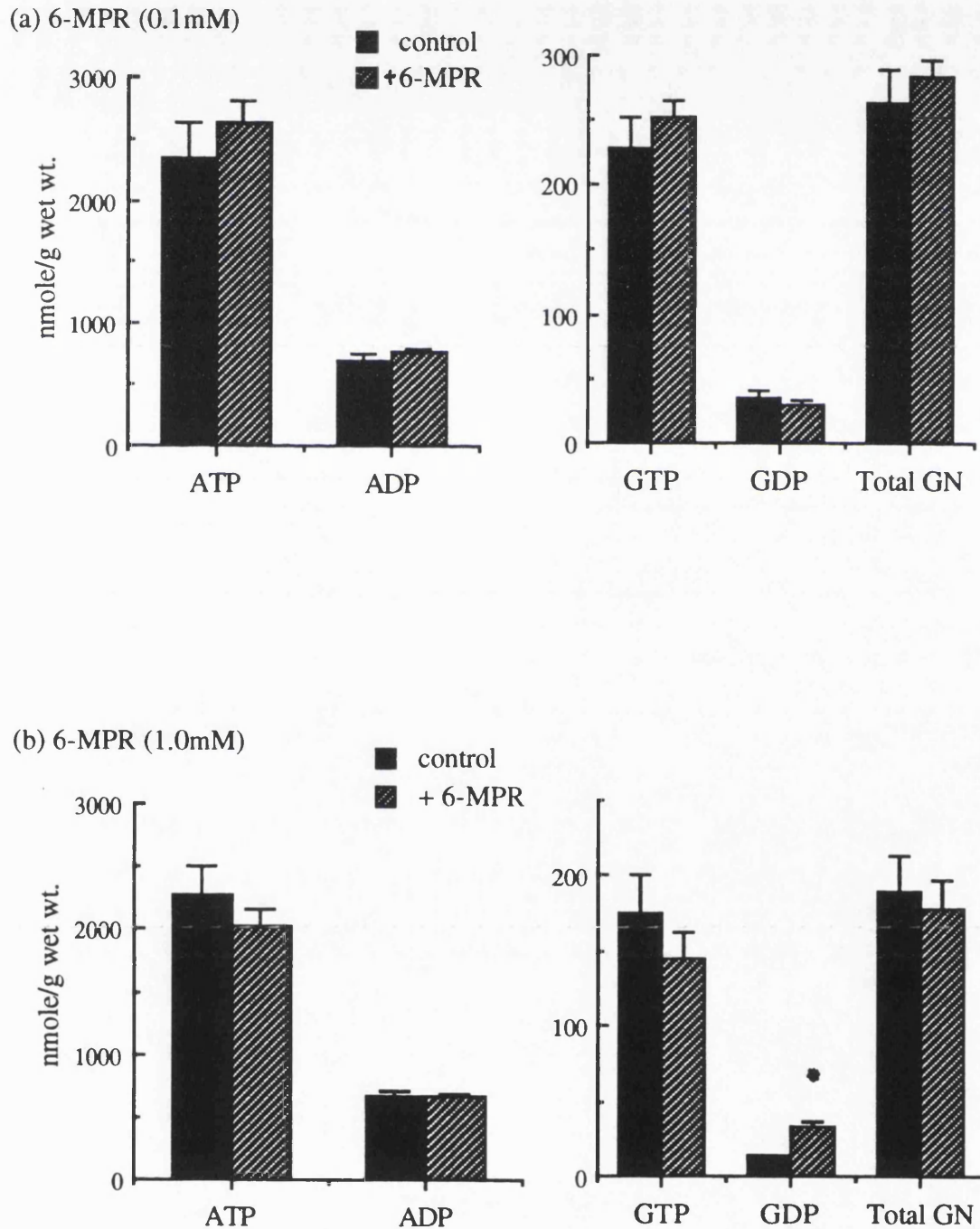

GTP concentrations between hearts that received 6-MPR and controls. Likewise, there was no significant difference in GDP concentrations in the first experiment (0.1 mM 6-MPR), but in the experiment using 1.0 mM 6-MPR the concentration of GDP in the control hearts was significantly lower than in the drug treated hearts. The reason for the somewhat lower concentrations of guanine nucleotides seen when 1 mM inhibitor was used (both in controls and drug treated) is not clear but cannot be due to the effect of any vehicle as 6-MPR is freely soluble in perfusion medium.

### 3.6.3 Ribavirin (series 8)

Ribavirin (1-β-ribofuranosyl-1,2,4-triazole-3-carboxamide) (also known as virazol) is an anti-viral agent which acts as a nucleotide analogue (Gilbert and Knight, 1986). Its 5'-monophosphate derivative is a potent inhibitor of IMP dehydrogenase (Streeter et al., 1973), and is produced by the action of adenosine kinase on ribavirin (Willis et al., 1978). Maximum inhibition of IMP dehydrogenase occurs at a concentration of 25 μM (Gilbert and Knight, 1986).

Ribavirin has the advantage of being both water soluble and non-phosphorylated and will therefore more easily cross the cell membrane. The addition of the drug 15 minutes before the onset of ischaemia should have allowed time for it to be activated by phosphorylation. The final concentration of



ribavirin in the perfusate was 2 mM. The results are shown in figure 3.12. Again, there was no significant difference in the concentrations of guanine or adenine nucleotides between drug treated and control hearts. One consequence of IMP-dehydrogenase inhibition may be an increase in the concentration of IMP. However, there was no significant difference in IMP concentration between control and ribavirin treated hearts (figure 3.12), nor for the hearts treated with the other drugs (data not shown).

#### 3.6.4 Conclusions

These results suggest that the synthesis of guanine nucleotides from the existing adenine nucleotide pool via the IMP-dehydrogenase pathway does not contribute significantly to the post-ischaemic recovery of guanine nucleotides. It could be that the drugs were not getting to their site of action in sufficient quantity to have an effect, due to their being metabolised or absorbed by endothelial cells before they could reach the myocytes. However, this would seem unlikely given the concentrations and variety of drug types used. Also, experiments performed later using isolated myocytes, which should overcome any such problems, showed essentially the same results (see chapter 4).

Legend to figure 3.12 (series 8)

All hearts had their atria removed and were perfused at a pressure of 130 cm H<sub>2</sub>O and electrically paced at 250 mV, 4 cycles per second. Hearts were initially perfused with recirculation for 20 minutes and were then subjected to 20 minutes of global no-flow ischaemia followed by 20 minutes of reperfusion. Ribavirin (2 mM) was added to the perfusion medium 15 minutes before the onset of ischaemia.

Data shown as mean ± standard error of 5 hearts.

Statistical analysis was by t-test.

**Figure 3.12** *Effect of ribavirin on the post-ischaemic recovery of guanine nucleotides in isolated perfused rat hearts (series 8)*

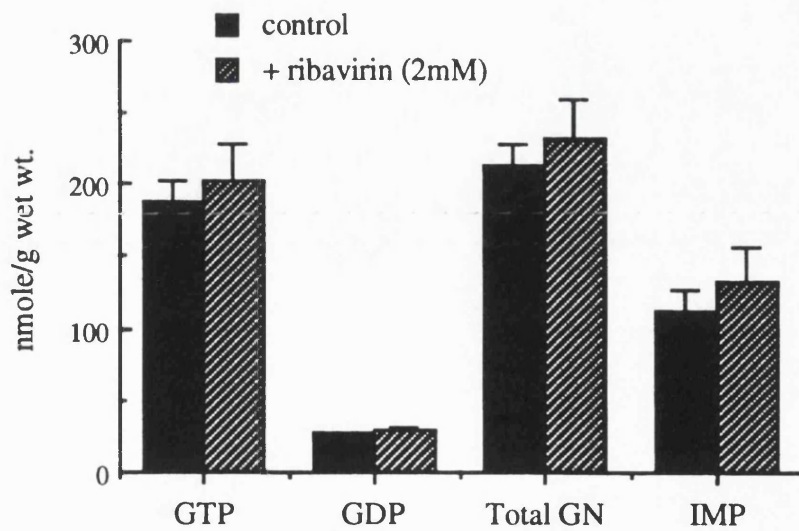
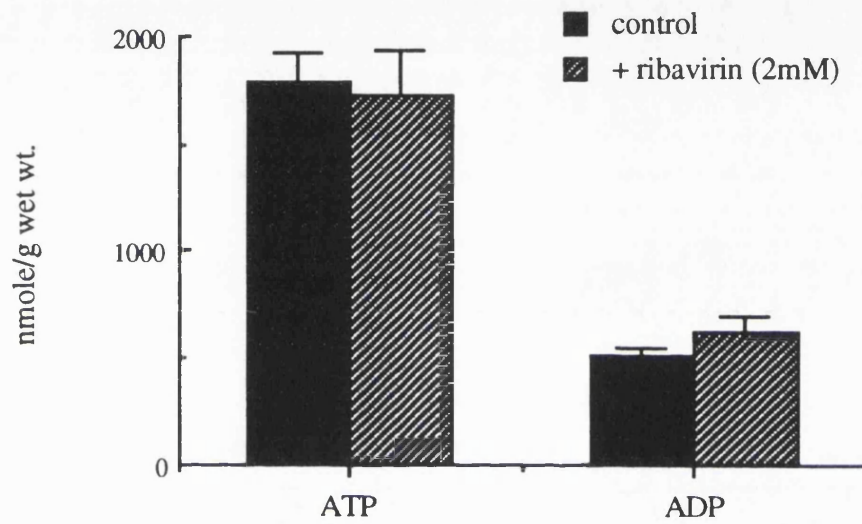

This leaves unanswered the question of the source of post-ischaemic guanine nucleotide recovery. It was decided that the best way to address this further might be to examine guanine nucleotide metabolism in isolated myocytes. This would have the advantage of overcoming complications arising from the compartmentation of metabolism between different cell types (see chapter 1), and would also avoid the possibility of drugs being taken up and metabolised by the endothelial cell barrier before they are able to enter the myocytes. These further studies on this problem are reported in chapter 4.

### **3.7 Effect of post-ischaemic changes in GTP content on GTP-dependent response to drugs (series 9-12)**

No conditions were found under which whole tissue total guanine nucleotide concentrations were consistently reduced relative to adenine nucleotide concentrations. However, it was evident that there may be enough variation in post-ischaemic recovery of guanine nucleotides between hearts to test whether there was any correlation between the GTP concentration or GTP/GDP ratio and the response of the heart to drugs and hormones that require GTP for their action.

### 3.7.1 Effect of GTP content on post-ischaemic response to adrenaline

Perfused hearts had their mechanical performance measured as described in section 2.4 and the oxygen consumption measured as described in section 2.5. The response to a standard dose of adrenaline ( $10^{-7}\text{M}$ ) under steady-state conditions was recorded both before and after a period of 20 minutes global no-flow ischaemia and the heart freeze-clamped and assayed for nucleotides as described in sections 2.6 and 2.7. The post-ischaemic response to adrenaline and the difference between the pre- and post-ischaemic response was calculated for each heart and compared with the GTP concentration and GTP/GDP ratio to see if there was any correlation. The difference between the pre- and post-ischaemic response was used to control as far as possible for any intrinsic variation in sensitivity to adrenaline between hearts. It would have been useful to have a measurement of the pre-ischaemic concentration of GTP for each heart as well as the value at freeze-clamping, to compare any change between the pre- and post-ischaemic response with changes in GTP content. However, this would require a non-invasive technique, of which none exist for GTP. The significance of any difference between the pre- and post-ischaemic response was determined using Student's paired t-test.

### 3.7.1.1 GTP content and metabolic response to adrenaline (series 9)

The results are shown in tables 3.15-3.17 and figures 3.13-3.15. On average there was no significant difference between the pre- and post-ischaemic response; the difference for some hearts being positive and for some negative. There was no significant correlation between the nucleotide content or ratios and either the post-ischaemic response or the difference between the pre- and post-ischaemic response for any of the parameters measured. Figures 3.13 to 3.15 show that this lack of correlation was evident over all ranges of GTP content, even for those with low levels of GTP where any rate-limiting effect of the GTP concentration may be more apparent.

One feature of figure 3.13 was that those hearts showing poor post-ischaemic recovery of GTP (ie <150 nmole/g wet wt.), showed a greater variability in the difference between the pre- and post-ischaemic inotropic response to adrenaline. However, a similar pattern was not evident for the chronotropic response or oxygen consumption.

Legend to tables 3.15-3.17 and figures 3.13 to 3.15

Hearts were recirculation perfused at a pressure of 70 cm H<sub>2</sub>O for at least 10 minutes to enable them to reach a steady-state, as determined by their force and rate of contraction and oxygen consumption. Adrenaline (10<sup>-7</sup>M) was then added and the resulting new steady-state performance recorded. The drug was then washed out of the heart with fresh perfusion medium until the performance had returned to previous values. Hearts were then subjected to 20 minutes of global no-flow ischaemia followed by reperfusion. When performance had resumed a new steady-state, addition of adrenaline was repeated and the resulting performance recorded. Hearts were then freeze-clamped and assayed for nucleotides as described in sections 2.6 and 2.7.

The difference between pre- and post-ischaemic response to adrenaline was calculated for each heart by subtracting the % increase in response seen before ischaemia (the control response) from the % increase in response seen after ischaemia.

Table 3.15 shows a summary of the data as mean ± standard error of 11 hearts.

Statistical analysis was by t-test.

\* = statistically significant P < 0.05

Data in tables 3.16 and 3.17 is the correlation coefficient calculated as described in section 2.2.

Figures 3.13-3.15 show the post-ischaemic response plotted against GTP content for each heart. The key to the symbols indicates the time in minutes following the start of reperfusion at which adrenaline was added (the first number in the key) and the time at which the heart was freeze-clamped (the second number in the key). This varied depending on how quickly the performance of the heart resumed a steady-state.

**Table 3.15** *Effect of ischaemia on metabolic response to adrenaline (summary of all 11 hearts of series 9)*

| <u>Protocol</u>      | Force<br>(arbitrary<br>units) | Heart rate<br>(beats/min) | Oxygen<br>consumption<br>( $\mu$ mole/min/<br>g wet wt.) |
|----------------------|-------------------------------|---------------------------|--|
| pre-<br>ischaemic:-  |                               |                           |  |
| basal                | 23.5<br>$\pm$ 1.7             | 247<br>$\pm$ 9            | 4.34<br>$\pm$ 0.16                                       |
| + adrenaline         | 31.4<br>$\pm$ 2.3             | 282<br>$\pm$ 8            | 6.73<br>$\pm$ 0.1  |
| % change             | +33.9<br>$\pm$ 5.3            | +14.9<br>$\pm$ 2          | +57.7<br>$\pm$ 7   |
| post-<br>ischaemic:- |                               |                           |  |
| basal                | 14.9<br>$\pm$ 0.6             | 241<br>$\pm$ 8            | 4.02<br>$\pm$ 0.18                                       |
| + adrenaline         | 21.4<br>$\pm$ 1               | 280<br>$\pm$ 9            | 5.96<br>$\pm$ 0.26                                       |
| % change             | +44.9<br>$\pm$ 7.5            | +16.1<br>$\pm$ 2          | 49.1<br>$\pm$ 4.8  |

Mean ATP content =  $2486 \pm 166$  nmole/g wet wt.

Mean GTP content =  $183 \pm 19$  nmole/g wet wt.

Mean ATP/ADP ratio =  $4.4 \pm 0.2$

Mean GTP/GDP ratio =  $8.5 \pm 0.9$



**Table 3.16** *Correlation between nucleotide content or ratio and post-ischaemic response to adrenaline (series 9)*

|                 | GTP     | GTP/GDP | ATP     | ATP/ADP |
|-----------------|---------|---------|---------|---------|
| force           | -0.4504 | -0.3299 | -0.3336 | 0.0966  |
| heart rate      | 0.0581  | -0.0665 | -0.0177 | -0.3061 |
| oxygen consump. | -0.1343 | -0.0033 | 0.1596  | -0.0132 |

**Table 3.17** *Correlation between nucleotide content or ratio and difference between pre- and post-ischaemic response to adrenaline (series 9)*

|                 | GTP     | GTP/GDP | ATP     | ATP/ADP |
|-----------------|---------|---------|---------|---------|
| force           | -0.0540 | 0.0069  | 0.0564  | 0.4827  |
| heart rate      | 0.3438  | -0.1914 | 0.4825  | 0.0039  |
| oxygen consump. | -0.5358 | -0.3103 | -0.2527 | -0.2841 |

Figure 3.13 Correlation of post-ischaemic GTP content and inotropic response to adrenaline of isolated perfused rat hearts (series 9)

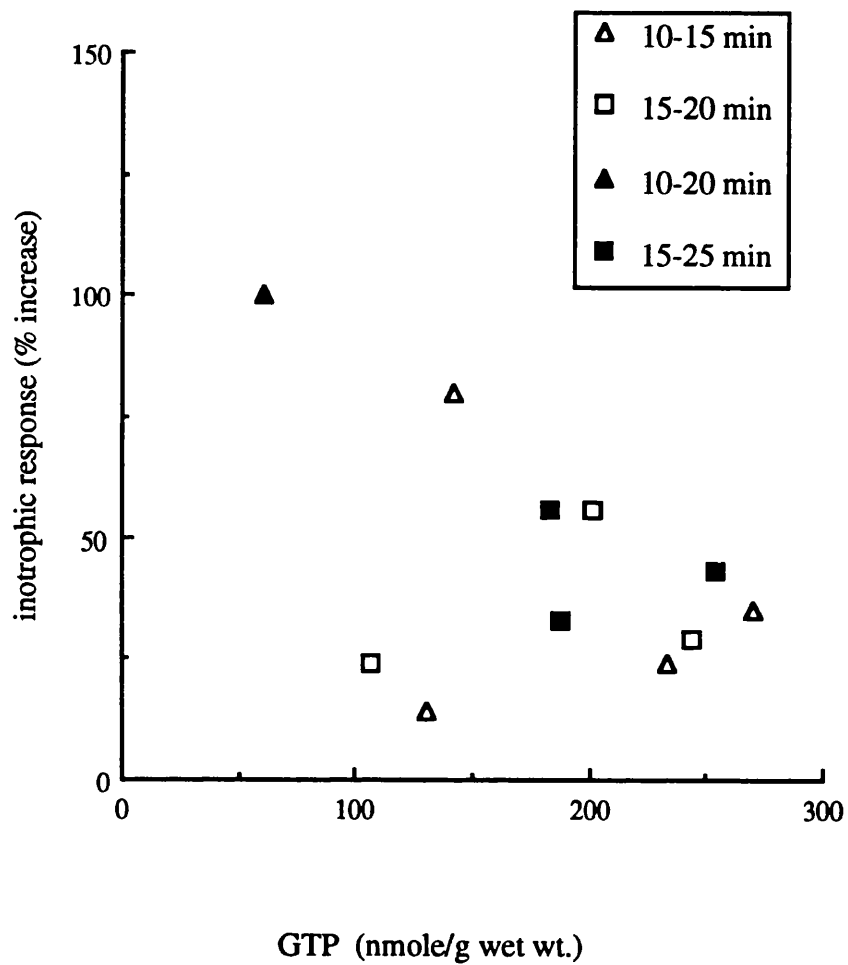

**Figure 3.14** *Correlation of post-ischaemic GTP content and chronotropic response to adrenaline of isolated perfused rat hearts (series 9)*

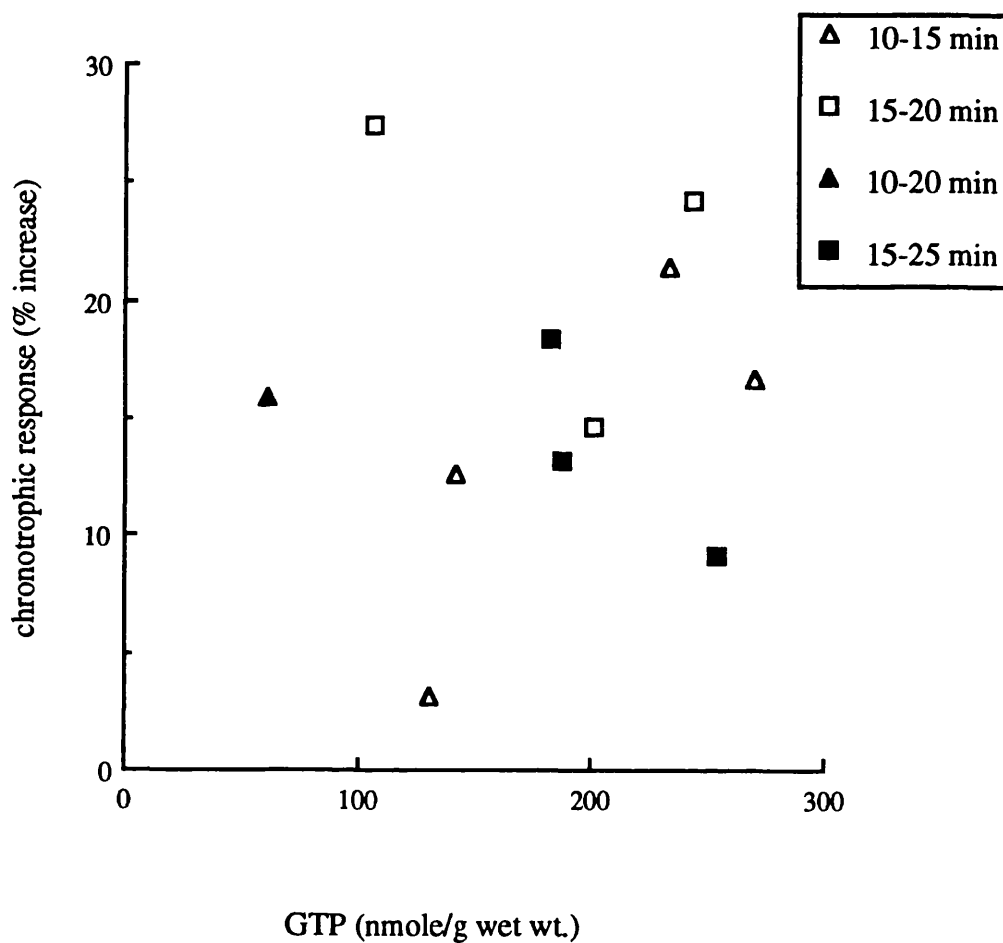

**Figure 3.15** *Correlation of post-ischaemic GTP content and changes in oxygen consumption to adrenaline of isolated perfused rat hearts (series 9)*

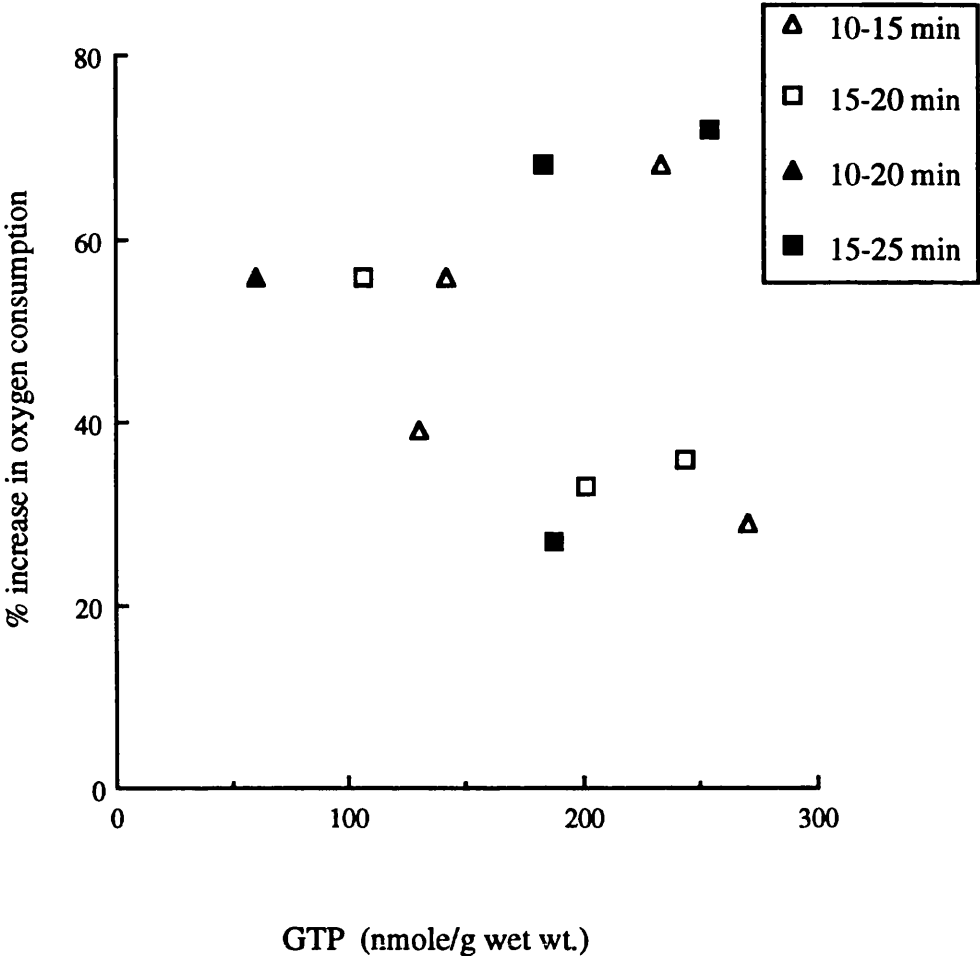

### 3.7.1.2 GTP content and mechanical response to adrenaline at increased workload (series 10)

Hearts were perfused as described in the previous section except that the workload was increased by perfusing at a pressure of 130 cm H<sub>2</sub>O, in the expectation that this may result in greater variation in GTP content. (The oxygen consumption was not measured). The results are shown in tables 3.18-3.20 and figures 3.16 and 3.17. The post-ischaemic inotropic response to adrenaline was significantly lower than the pre-ischaemic response; all except one heart showed a reduction in inotropic response to adrenaline after ischaemia.

Similarly, all except one heart showed a reduced chronotropic post-ischaemic response to adrenaline compared with the pre-ischaemic response; (this was not however the same heart which showed the anomalous inotropic response mentioned above). However, taking the average of all 7 hearts there was no significant reduction in chronotropic response after ischaemia. Although most of the correlation coefficients were positive, these were not statistically significant except for the positive correlation between the ATP content and the difference in the pre- and post-ischaemic heart-rate response ( $P < 0.05$ ). Consistent with the earlier results, those hearts with lower than average GTP concentrations also had lower than average ATP concentrations.

Legend to tables 3.18-3.20 and figures 3.16 and 3.17

Hearts were recirculation perfused at a pressure of 130 cm H<sub>2</sub>O for at least 10 minutes to enable them to reach a steady-state, as determined by their force and rate of contraction. Adrenaline (10<sup>-7</sup>M) was then added and the resulting new steady-state performance recorded. The drug was then washed out of the heart with fresh perfusion medium until the performance had returned to previous values. Hearts were then subjected to 20 minutes of global no-flow ischaemia followed by reperfusion. When performance had resumed a new steady-state, addition of adrenaline was repeated and the resulting performance recorded. Hearts were then freeze-clamped and assayed for nucleotides as described in sections 2.6 and 2.7.

The difference between pre- and post-ischaemic response to adrenaline was calculated for each heart by subtracting the % increase in response seen before ischaemia (the control response) from the % increase in response seen after ischaemia.

Table 3.18 shows a summary of the data as mean ± standard error of 7 hearts.

Data in tables 3.19 and 3.20 is the correlation coefficient calculated as described in section 2.2.

Statistical analysis was by t-test.

\* = statistically significant correlation 'P < 0.05

Figures 3.16-3.17 show the post-ischaemic response plotted against GTP content for each heart. The key to the symbols indicates the time in minutes following the start of reperfusion at which adrenaline was added (the first number in the key) and the time at which the heart was freeze-clamped (the second number in the key). This varied depending on how quickly the performance of the heart resumed a steady-state.

**Table 3.19** *Correlation between nucleotide content or ratio and post-ischaemic mechanical response to adrenaline at increased workload (series 10)*

|            | GTP    | GTP/GDP | ATP     | ATP/ADP |
|------------|--------|---------|---------|---------|
| force      | 0.2576 | 0.0790  | 0.4861  | 0.3824  |
| heart rate | 0.4774 | 0.4068  | 0.7892* | 0.7285  |

**Table 3.18** *Effect of ischaemia on mechanical response to adrenaline at increased workload (summary of 7 hearts of series 10)*

| <u>Protocol</u>      | Force<br>(arbitrary<br>units) | Heart rate<br>(beats/min) |
|----------------------|-------------------------------|---------------------------|
| pre-<br>ischaemic:-  |                               |                           |
| basal                | 10.0<br>±2.1                  | 236<br>±8                 |
| + adrenaline         | 15.6<br>±3.7                  | 265<br>±16                |
| % change             | +49.7<br>±8.8                 | +12.5<br>±5.2             |
| post-<br>ischaemic:- |                               |                           |
| basal                | 6.0<br>±0.5                   | 231<br>±8                 |
| + adrenaline         | 7.3<br>±0.6                   | 243<br>±13                |
| % change             | +23.0<br>±9.7                 | +5.2<br>±2                |

Mean ATP content = 1957 ± 212 nmole/g wet wt.

Mean GTP content = 148 ± 13 nmole/g wet wt.

Mean ATP/ADP ratio = 3.8 ± 0.2

Mean GTP/GDP ratio = 5.5 ± 0.5

**Table 3.20** *Correlation between nucleotide content or ratio and difference between pre- and post-ischaemic mechanical response to adrenaline at increased workload (series 10)*

|               | GTP    | GTP/GDP | ATP     | ATP/ADP |
|---------------|--------|---------|---------|---------|
| force         | 0.7402 | 0.6384  | 0.1504  | 0.2393  |
| heart<br>rate | 0.3945 | 0.4367  | -0.2576 | 0.0690  |

**Figure 3.16** *Correlation of post-ischaemic GTP content and inotropic response to adrenaline of isolated perfused rat hearts subjected to increased workload (series 10)*

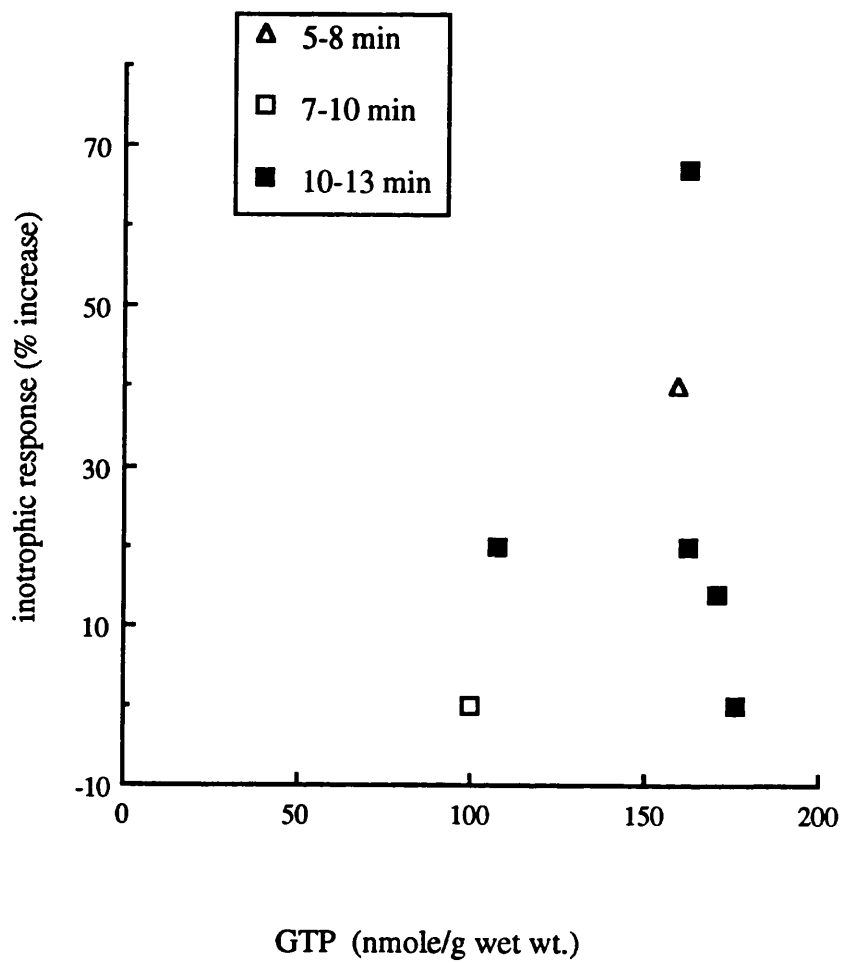



**Figure 3.17** *Correlation of post-ischaemic GTP content and chronotropic response to adrenaline of isolated perfused rat hearts subjected to increased workload (series 10)*

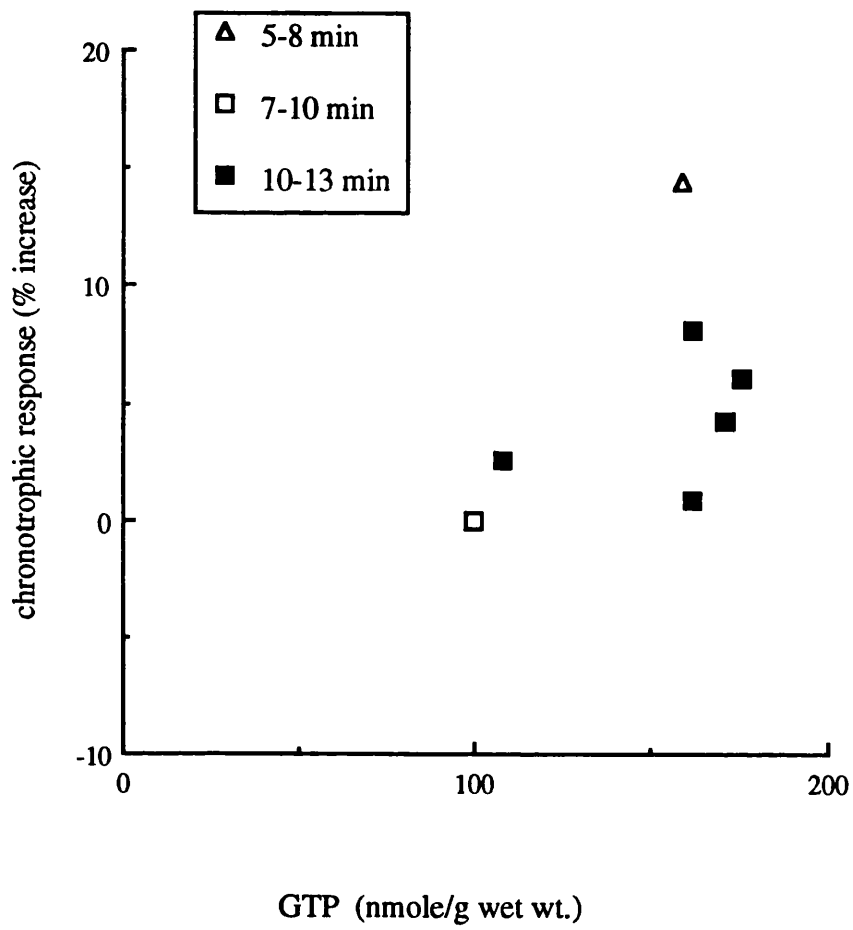

Bearing in mind that these hearts were from a different batch of rats, it was noticeable that the average concentration of both ATP and GTP in these hearts (1957 and 148 nmole/g wet wt respectively) was less than that of the previous series, presumably because the increased workload resulted in a greater rate of consumption of ATP.

### 3.7.1.3 Conclusions

The absence of any correlation between the whole heart guanine nucleotide content or ratio and the post-ischaemic response to adrenaline could be due to the low  $K_m$  value for binding of GTP to G-proteins ( $0.3 \mu\text{M}$ ) (Brandt and Ross, 1985), so that the GTP content or GTP/GDP ratio never fell low enough to become the rate-limiting factor in G-protein action. Also, the supply of GTP to G-proteins may be controlled locally by membrane associated nucleoside diphosphate kinase (Kimura and Shimada, 1988), making whole cell GTP content a poor indicator of GTP availability to the G-protein (see section 1.4.1.3). Another problem is that to measure post-ischaemic responses to agonists, it was necessary to wait until the mechanical performance and oxygen consumption had returned to steady-state values, which usually took about 10-15 minutes, by which time the GTP content had fully or almost fully recovered in most of the hearts. The spread of GTP values may therefore not have been great enough to significantly affect the response of

the heart to adrenaline. Also, in order to determine the effect of GTP concentration or GTP/GDP ratio on the response to adrenaline, it is necessary to obtain conditions under which the GTP content varies while all other conditions likely to affect the response, such as ATP concentration, show minimal variation. However, results from these hearts and the earlier sets of perfusions suggest that changes in GTP content tend to parallel those of ATP, making it difficult to determine the effect of changes in GTP concentration alone.

### 3.7.2 Effect of ischaemia on response to carbachol (series 11 and 12)

Because of the relatively high  $K_m$  of both soluble and particulate guanylate cyclase for GTP (10-100  $\mu M$ ) (Tremblay et al., 1988), it was decided to test whether GTP availability after ischaemia is a rate-limiting factor in the signal transmission process for muscarinic stimulation. Hearts were therefore subjected to periods of ischaemia and reperfusion and the response to carbachol determined by measuring the cGMP content as explained in section 2.8. The results are shown in tables 3.21-3.23 and figures 3.18 and 3.19.

Reperfusion following 20 and 30 minutes of ischaemia resulted in ATP concentrations of about 70% and 50%

respectively of their pre-ischaemic (control) value (table 3.21). There was no significant difference between hearts that were reperfused for 5 minutes or 10 minutes. ADP concentrations were significantly lower than the control only on reperfusion after 20 minutes ischaemia (not after 30 minutes ischaemia), while the ATP/ADP ratio was significantly lower than controls only on reperfusion after 30 minutes ischaemia. Again, there was no difference between hearts reperfused for 5 or 10 minutes. The GTP concentration in hearts reperfused for either 5 or 10 minutes following 30 minutes of ischaemia was about 50% of the control value (table 3.21), thus resembling the changes to ATP. However, following 20 minutes of ischaemia the GTP content was significantly lower than the control only in those hearts reperfused for 5 minutes. There were no significant changes to the GDP content or the GTP/GDP ratio in any of the hearts.

There was a significant difference ( $P < 0.05$ ) in the control concentration of GTP between the two series of perfusions. Both perfusions were carried out under identical conditions but about two months apart (June and August). The reason for this is unclear and may be a further manifestation of seasonal changes or inter-batch variations discussed in section 3.1 and observed in series 2 and 3. The large difference in GTP content is particularly interesting given the similar control ATP content of the two series.

Legend to tables 3.21-3.23 and figures 3.18 and 3.19

All hearts were perfused at a pressure of 130 cm H<sub>2</sub>O. Control hearts were freeze-clamped after 20 minutes of recirculation only, while experimental hearts were additionally subjected to 20 minutes (series 11) or 30 minutes (series 12) of global no-flow ischaemia, followed by 5 or 10 minutes of reperfusion before freeze-clamping. All hearts received carbachol (10<sup>-6</sup>M), which was injected into the reservoir of the perfusion apparatus three minutes before freeze-clamping. Heart tissue was then extracted and analysed for purine nucleotides as described in sections 2.6, 2.7 and 2.8.

I = ischaemia  
R = reperfusion

Data in table 3.21 shown as mean ± standard error for 7 or 8 hearts except were stated. \* = significantly different from control value P < 0.05.

Data in tables 3.22 and 3.23 are the correlation coefficients calculated as described in section 2.2.  
\* = statistically significant correlation p < 0.05.

Statistical analysis was by t-test.

Figures 3.18 and 3.19 show plots of GTP versus cGMP, each point representing data from one heart.

**Table 3.21** *Effect of carbachol on cGMP concentration following ischaemia and increased workload in isolated perfused rat hearts (series 11 and 12)*

nmole/g wet wt. except cGMP = pmol/g wet wt.

|                      | ATP           | ADP         | ATP/<br>ADP  | GTP         | GDP       | GTP/<br>GDP | cGMP      |
|----------------------|---------------|-------------|--------------|-------------|-----------|-------------|-----------|
| series<br>11         |               |             |              |             |           |             |           |
| control              | 3314<br>±232  | 817<br>±40  | 4.1<br>±0.3  | 214<br>±17  | 36<br>±4  | 6.3<br>±0.8 | 35<br>±4  |
| 20 min I<br>5 min R  | 2268*<br>±135 | 669*<br>±30 | 3.4<br>±0.2  | 157*<br>±17 | 29<br>±2  | 5.5<br>±0.7 | 34<br>±3  |
| 20 min I<br>10 min R | 2351*<br>±150 | 689*<br>±19 | 3.4<br>±0.2  | 165<br>±13  | 30<br>±2  | 5.6<br>±0.5 | 42<br>±3  |
| series<br>12         |               |             |              |             |           |             |           |
| control<br>(n=3)     | 2904<br>±317  | 780<br>±114 | 3.8<br>±0.3  | 300<br>±31  | 74<br>±15 | 4.2<br>±0.6 | 29<br>-   |
| 30 min I<br>5 min R  | 1422*<br>±120 | 617<br>±30  | 2.3*<br>±0.2 | 141*<br>±12 | 48<br>±2  | 2.9<br>±0.2 | 24*<br>±1 |
| 30 min I<br>10 min R | 1497*<br>±104 | 626<br>±32  | 2.4*<br>±0.2 | 143*<br>±6  | 45<br>±4  | 3.4<br>±0.4 | 28<br>±3  |

**Table 3.22** *Correlation between post-ischaemic content of cGMP and other purine nucleotides and ratios after perfusion of rat hearts with carbachol (series 11 and 12)*

Correlation coefficient between cGMP and:-

|                      | ATP     | ADP     | ATP/ADP |
|----------------------|---------|---------|---------|
| series 11            |         |         |         |
| control              | 0.2093  | 0.1288  | 0.1161  |
| 20 min I<br>5 min R  | 0.4931  | 0.2103  | 0.3861  |
| 20 min I<br>10 min R | 0.4086  | 0.3709  | 0.2873  |
| series 12            |         |         |         |
| control<br>(n=3)     | -       | -       | -       |
| 30 min I<br>5 min R  | -0.2337 | 0.0939  | -0.2964 |
| 30 min I<br>10 min R | 0.0349  | -0.2344 | 0.2224  |

|                      | GTP     | GDP    | GTP/GDP | ATP/GTP |
|----------------------|---------|--------|---------|---------|
| series 11            |         |        |         |         |
| control              | 0.3901  | 0.1404 | 0.1033  | -0.2559 |
| 20 min I<br>5 min R  | 0.2743  | 0.3277 | 0.0824  | -0.1250 |
| 20 min I<br>10 min R | 0.6355  | 0.1088 | 0.5094  | -0.5511 |
| series 12            |         |        |         |         |
| control<br>(n=3)     | -       | -      | -       | -       |
| 30 min I<br>5 min R  | -0.2599 | 0.1470 | -0.4072 | -0.0374 |
| 30 min I<br>10 min R | 0.1396  | 0.3878 | -0.3813 | -0.0638 |

**Table 3.23** *Correlation between post-ischaemic ATP and GTP and between nucleotide ratios after perfusion of rat hearts with carbachol (series 11 and 12)*

correlation coefficient between:-

|                      | ATP & GTP | ATP/ADP & GTP/GDP |
|----------------------|-----------|-------------------|
| series 11            |           |                   |
| control              | 0.6499    | 0.8494*           |
| 20 min I<br>5 min R  | 0.8878*   | 0.4966            |
| 20 min I<br>10 min R | 0.7624*   | 0.6872            |
| series 12            |           |                   |
| control<br>(n=3)     | 0.5241    | -0.3343           |
| 30 min I<br>5 min R  | 0.9602*   | 0.9307*           |
| 30 min I<br>10 min R | 0.9174*   | 0.3669            |



**Figure 3.18** *Correlation of post-ischaemic GTP and cGMP content in response to carbachol in isolated perfused rat hearts subjected to increased workload (series 11)*

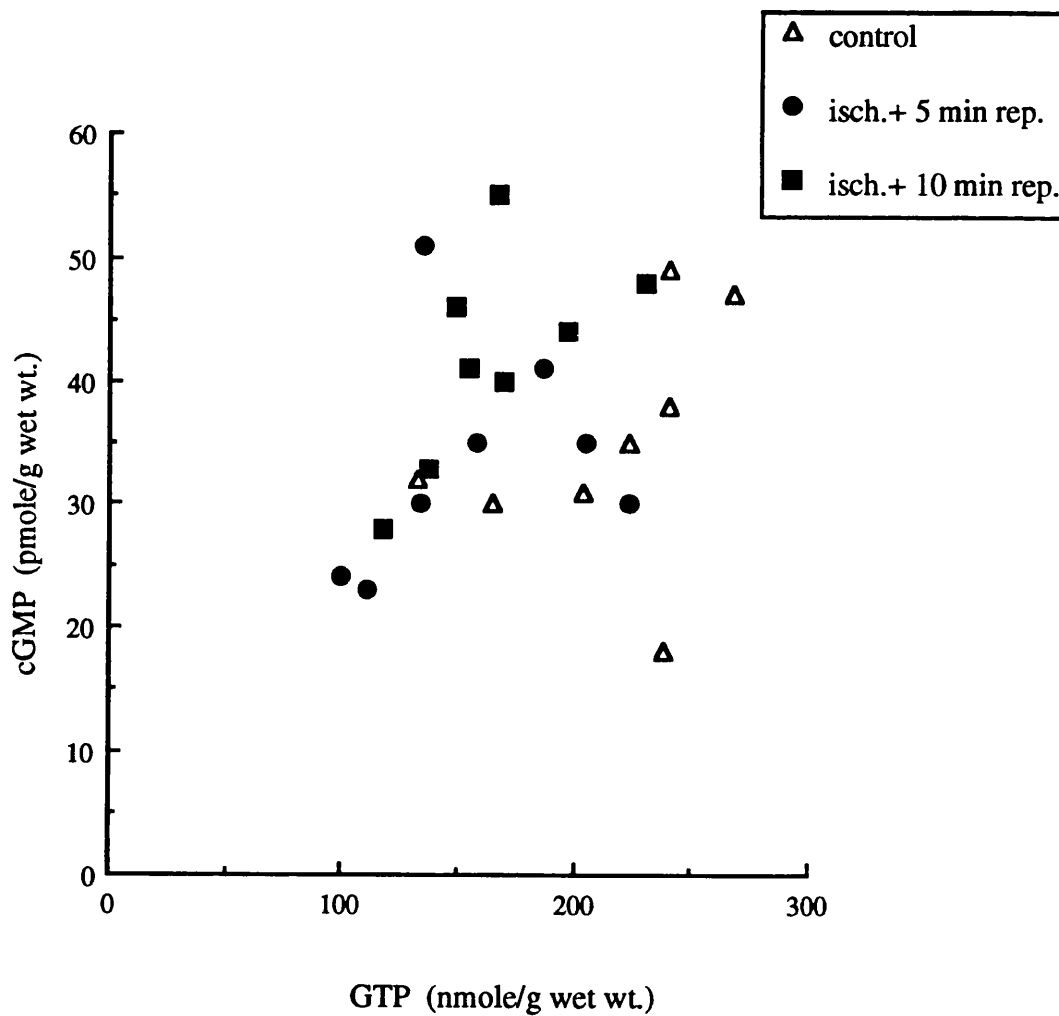
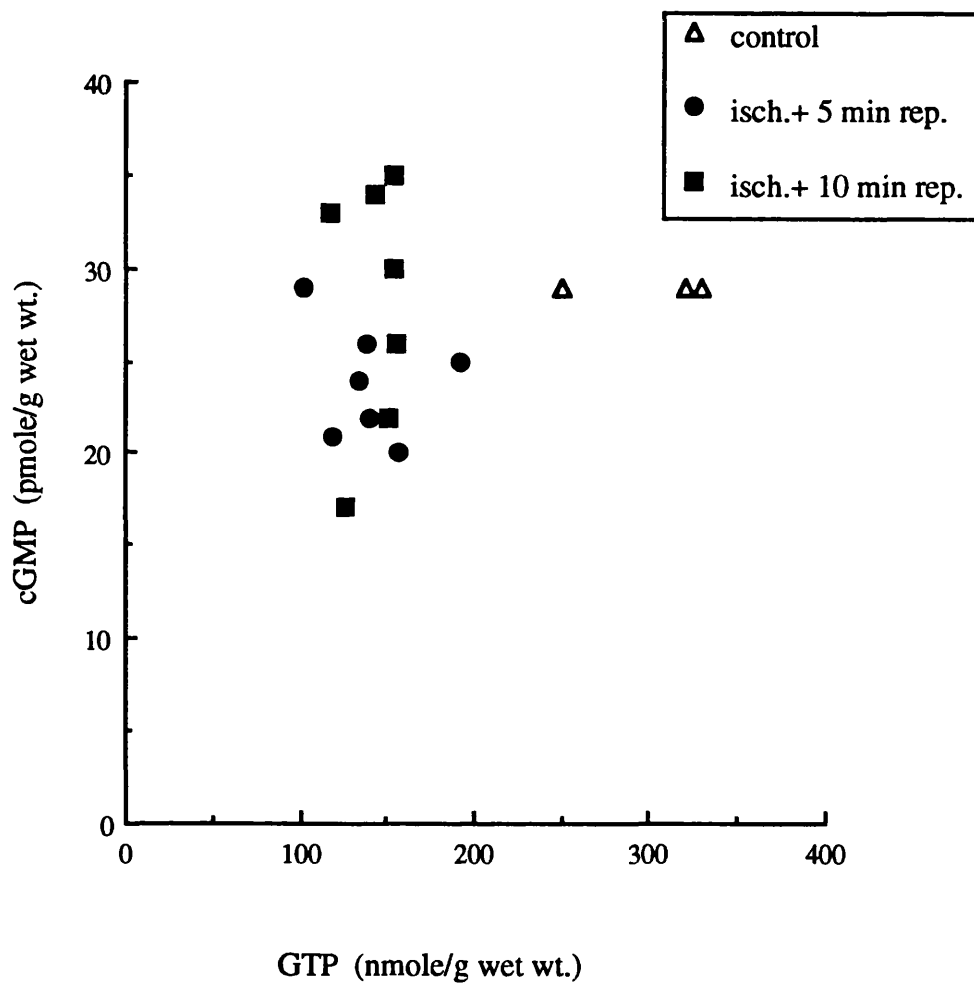

Figure 3.19 Correlation of post-ischaemic GTP and cGMP content in response to carbachol in isolated perfused rat hearts subjected to increased workload (series 12)



The pre-ischaemic cGMP content in the presence of carbachol was about 30-35 pmole/g wet wt., which showed no significant change during the experiment except for the hearts subjected to 30 minutes of ischaemia and 5 minutes of reperfusion, where the concentration was about 80% of the control value. Gardner and Allen (1976) measured basal concentrations of cGMP in perfused rat heart of about 18 pmole/g wet wt., which increased about three-fold to 50-55 pmole/g wet wt one minute after perfusion with 1  $\mu$ M acetylcholine and then declined slowly to about 40 pmole/g wet wt. after 6 minutes. George et al., (1970) obtained basal values of about 120 pmole/g wet wt., increasing about 2.5-fold following administration of acetylcholine. These differences and the lower cGMP content following muscarinic stimulation in the present study may be due to the different experimental conditions; Gardner and Allen electrically paced the hearts while in the present study the hearts were not paced but subjected to increased workload by perfusing at a pressure of 130 cm H<sub>2</sub>O. Carbachol was used because it has a similar potency to acetylcholine at muscarinic receptors but has a longer period of action as it resists hydrolysis by acetylcholinesterases (Rang and Dale, 1987).

There was no significant correlation between the cGMP concentration and that of GTP, GDP, ATP, ADP, or the nucleotide ratios (table 3.22 and figures 3.18 and 3.19). The absence of significant changes in the cGMP content in

most cases, coupled with the lack of correlation, suggests that neither the GTP content nor the GTP/GDP ratio fell low enough to become the rate-limiting factor in guanylate cyclase activity. In the case of 30 minutes ischaemia plus 5 minutes reperfusion, the cGMP content was significantly lower than the control. However, this was evidently not due to reduced GTP content as hearts subjected to 30 minutes ischaemia plus 10 minutes of reperfusion had a similar GTP concentration but a cGMP concentration that was not significantly different from the control. Indeed, the lowest GTP concentration seen in individual hearts was about 100 nmole/g wet wt., representing a concentration of about 200  $\mu$ M, still considerably higher than the  $K_m$  for guanylate cyclase of 10-100  $\mu$ M (Tremblay et al., 1988). There was also no evidence for the inhibition of guanylate cyclase by ATP or ADP, as a negative correlation between these nucleotides and cGMP would be expected if this was the case. Finally, to test the possibility that the effect of reduced GTP content on guanylate cyclase was being cancelled out by an equal and opposite effect of reduced ATP concentration, the correlation between the cGMP content and the ATP/GTP ratio was calculated. A negative correlation would be expected, and although the correlation coefficient in each case was actually negative, none of the values were statistically significant.

The content of cGMP also depends on the activity of cGMP-phosphodiesterases, and it is possible that a reduction in

the activity of these after ischaemia could mask any reduction in guanylate cyclase activity.

One limitation of these results is that the nucleotide measurements relate to the whole heart and take no account of possible compartmentation between different cell types or between different regions of the heart. Therefore any possible correlation between GTP and cGMP content in a subset of cells, such as the atria, would probably be masked by the contribution from the rest of the heart.

Table 3.23 shows that there was a significant positive correlation between ATP and GTP concentrations for hearts subjected to ischaemia and reperfusion but not for pre-ischaemic (control) hearts. This was in agreement with the results of series 3 hearts which were subjected to various periods of reperfusion following 20 minutes of ischaemia (section 3.4). The significant positive correlation between the ATP/ADP and GTP/GDP ratios in only two sets of hearts, while the others showed no significant correlation, has no obvious explanation but may be due to the measured nucleotide concentrations not reflecting the content of free metabolically active nucleotide.

## CHAPTER 4 MYOCYTES - RESULTS AND DISCUSSION

Adult rat myocytes were isolated and incubated to investigate (i) the pathway of guanine nucleotide recovery following periods of anoxia and (ii) the compartmentation of these pathways between different cell types.

### 4.1 Development of method for isolation of viable rat cardiac myocytes (series 1 and 2)

The viability of the cells was determined both morphologically and by measuring the ATP content and ATP/ADP ratio. Viable cells have clearly visible striations, a length:width ratio of more than five, which indicates that they are not hypoxic, and they exclude Trypan Blue showing that their membranes are still intact (Piper et al., 1982).

The results are shown in tables 4.1 to 4.4. As explained in section 2.9, the method of De Young et al. (1989), involving perfusion with Joklik medium, was initially tested but consistently poor yields were obtained (<10% viable cells) so the purine content was not measured. The method based on Haworth et al., (1989), involving perfusion with modified Krebs-Henseleit buffer was then tried (series

1). Subsequent purification and incubation in Krebs-Henseleit buffer (+ HEPES) resulted in better yields of viable cells (56%), but the long-term viability of the cells was poor; both the ATP content and ATP/ADP ratio falling considerably over a period of 30 minutes in two out of three preparations. Addition of BSA (1%) to the Krebs-Henseleit buffer before the purification stage resulted in some improvement in ATP content, although longer-term viability was still poor. Finally, when cells were purified and incubated in Joklik MEM (+ 1% BSA + HEPES) the number of viable cells increased to about 66% and in most of the preparations there was a considerable improvement in both the initial value and long-term maintenance of the ATP content and ATP/ADP ratio (series 2). This method was therefore used for all subsequent experiments (see section 2.9).

The yield of viable cells in series 2 of 66% compares with 73% (De Young et al. 1989), 72% (Altschuld et al., 1987) and 85% (Geisbuhler et al. 1984).

The purine content was calculated as nmoles per million cells as described in section 2.9. Many previous workers have expressed cell nucleotide content as per mg of protein (Geisbuhler et al., 1984), but the presence of 1% BSA in the incubation medium in the present study would render such measurements inaccurate. The initial concentration of ATP in series 2 of about 300 nmoles/10<sup>6</sup> cells compares

favourably with that of previous studies. De Young et al., (1989), using Joklik medium for both isolation and incubation of calcium-tolerant myocytes, obtained ATP concentrations of 300-400 nmole/ $10^6$  cells, while Altschuld et al. (1987), using Krebs-Henseleit medium for both isolation and incubation, obtained ATP concentrations of about 150 nmole/ $10^6$  cells. On the other hand, the initial ATP/ADP ratio of approximately 7.0 is lower than the figure of 10 obtained by Piper et al., (1982) and by De Young et al., (1989), but is comparable to the value of 6.3-7.5 obtained by Altschuld et al. (1987).

The differences in ATP content and adenine nucleotide ratios probably reflect both the different percentages of viable cells obtained and also the different methods employed for the isolation, incubation and extraction of the cells. Non-viable cells retain ADP bound to actin (about 2 nmole ADP/200,000 cells) (Altschuld et al., 1985), so a high proportion of these in the preparation will depress the ATP/ADP ratio. Also, previous studies have used perchloric acid for nucleotide extraction (rather than a TCA/methanol mixture), and this may not inactivate creatine kinase or adenylate kinase (Williamson and Corkey, 1969) resulting in reduced ATP content.



Legend to tables 4.1 to 4.4. (series 1 and 2).

Adult rat ventricular myocytes were isolated by perfusing rat hearts with Krebs-Henseleit buffer containing collagenase as described in section 2.9.1.2. The cells were then purified as described in section 2.9.1.3, except that the first four preparations (series 1) were resuspended in Krebs-Henseleit buffer containing HEPES (with or without BSA). The cells were incubated at 37°C for various time periods as described in section 2.9.2. in either Krebs-Henseleit buffer (series 1) or Joklik MEM (series 2) and then extracted and analysed for purine compounds as described in section 2.9.3.

**Table 4.1** *Yield of rod-shaped viable rat myocytes isolated using different resuspension buffers*

| series no. | Resuspension buffer   | % viable cells |
|------------|-----------------------|----------------|
| 1 (n=3)    | Krebs-Henseleit       | 56.0 ±10       |
| 1 (n=1)    | Krebs-Henseleit + BSA | 57.0           |
| 2 (n=7)    | Joklik MEM + BSA      | 66.4 ±1.6      |

**Table 4.2** *Concentration of ATP in isolated rat myocytes incubated in different buffers*

nmole/10<sup>6</sup> cells

Incubation time (min)

| Buffer                       | 0                 | 30                | 45                | 60                 |
|------------------------------|-------------------|-------------------|-------------------|--------------------|
| Krebs-Henseleit<br>n=3       | -                 | 118<br>±27        | -                 | 61<br>±22          |
| Krebs-Henseleit<br>+ BSA n=1 | -                 | 209               | -                 | 112                |
| Joklik MEM + BSA             | 309<br>±34<br>n=5 | 327<br>±42<br>n=5 | 334<br>±11<br>n=2 | 320<br>±160<br>n=2 |

**Table 4.3** *ATP/ADP ratio in isolated rat myocytes incubated in different buffers*

nmole/10<sup>6</sup> cells

Incubation time (min)

| Buffer                       | 0                  | 30                 | 45                 | 60                 |
|------------------------------|--------------------|--------------------|--------------------|--------------------|
| Krebs-Henseleit<br>n=3       | -                  | 4.6<br>±0.6        | -                  | 2.8<br>±1.3        |
| Krebs-Henseleit<br>+ BSA n=1 | -                  | 4.2                | -                  | 2.4                |
| Joklik MEM + BSA             | 7.2<br>±0.2<br>n=5 | 8.0<br>±0.7<br>n=5 | 7.4<br>±0.2<br>n=2 | 7.0<br>±0.4<br>n=2 |

**Table 4.4** *Concentration of GTP in isolated rat myocytes incubated in different buffers*

nmole/10<sup>6</sup> cells

Incubation time (min)

| Buffer                       | 0                   | 30                  | 45                  | 60                  |
|------------------------------|---------------------|---------------------|---------------------|---------------------|
| Krebs-Henseleit<br>n=3       | -                   | 4.3<br>±0.6         | -                   | 2.7<br>±0.1         |
| Krebs-Henseleit<br>+ BSA n=1 | -                   | 8.6                 | -                   | 3.1                 |
| Joklik MEM + BSA             | 12.6<br>±2.3<br>n=5 | 13.0<br>±2.3<br>n=5 | 15.3<br>±2.0<br>n=2 | 11.0<br>±6.2<br>n=2 |

The concentration of GTP in these preparations is shown in table 4.4. Cells incubated in Krebs-Henseleit buffer had low concentrations of GTP which decreased further during incubation. Cells incubated in Joklik MEM had much higher concentrations of GTP (about 10-15 nmoles/ $10^6$  cells), which showed little change during incubation for up to 45 minutes in five out of the seven preparations. This was in contrast to some earlier studies which have shown lower values and some deterioration with time. Geisbuhler et al. (1984) reported concentrations of GTP in rat ventricular myocytes of only 2.2 nmole/ $10^6$  cells, which fell to undetectable levels after 30 minutes of aerobic incubation; and a GTP/GDP ratio of only 0.8, the latter due to about 50% of the guanine nucleotide being GDP. Geisbuhler et al. also detected small amounts of GMP (0.4 nmole/ $10^6$  cells). Altschuld et al. (1987), also using rat ventricular myocytes, reported a GTP content of 3.0 nmole/ $10^6$  cells which was, however, maintained during 60 minutes of aerobic incubation. The reason for the low values obtained previously is not clear but was not due to de-energisation of the cells as both these earlier studies obtained an ATP/ADP ratio of about 6.0 and an energy charge of about 0.90. The fact that Geisbuhler et al. also obtained a low GTP content and GTP/GDP ratio from fresh rat heart ventricle suggests that their extraction procedure resulted in considerable hydrolysis of GTP. Both these earlier works obtained ATP and GTP levels that were respectively about one-third and about one-fifth of those of series 2 in the

present study, suggesting lower preservation of GTP compared to ATP.

The ratio of total adenine to guanine nucleotides in rat myocytes in the present study was about 20, which was similar to that obtained by Geisbuhler et al. (1984). This is higher than the ratio of 12-15 obtained in the isolated perfused rat hearts (chapter 3). This could be due to differences in purine nucleotide content between myocytes and other cell types in the heart or to the rapid beating of the perfused hearts resulting in a greater rate of ATP usage than in isolated myocytes. It may also be that only those myocytes with a high ATP content survive the isolation procedure, or that the isolation procedure causes preferential loss of guanine nucleotides. Evidence of compartmentation of nucleotides between various cell types in the heart came from the finding that endothelial cells in guinea pig hearts contained about three times the adenine nucleotide concentration than whole hearts (Nees and Gerlach, 1983). However, given that endothelial cells account for only 2-4% of myocardial weight (Manfredi and Holmes, 1985), their adenine/guanine nucleotide ratio would need to be much lower than that of whole hearts to explain the differences observed.

#### 4.2 Effect of anoxia and ribavirin on purine nucleotides in isolated rat myocytes (series 3)

Myocytes were isolated and checked for viability, as described in section 2.9.1. The myocyte preparation was divided into six equal volume aliquots (each 0.4-0.6 ml) and subjected to an initial 10 minutes of aerobic incubation at 37°C. Ribavirin was added to the appropriate aliquots at the start of this period to allow time for uptake by the cells and activation by phosphorylation. Time-control aliquots were then incubated aerobically for a further 0, 30 and 45 minutes. Experimental aliquots were subjected to 30 minutes anoxia (by gassing with N<sub>2</sub> in a sealed jar as described in section 2.9.2.) with or without a further 15 minutes of aerobic incubation. Glucose (5.5 mM) was present throughout the experiment. Aliquots were then extracted and analysed for purine compounds as described in section 2.9.3.

The results are summarised in tables 4.5 to 4.7. The time-control aliquots showed that there was no significant change in the ATP content or ATP/ADP ratio during the course of the experiment. Furthermore, examination of cell morphology showed an initial value of 66.4% ±1.92 (mean ± SE, n = 5) viable cells and this did not change significantly in either the control or experimental aliquots during the course of the experiment. Therefore any change observed in the experimental incubates was not due

to deterioration of the myocyte preparation. The time-controls also showed that there were no significant changes to any of the other purine compounds during the course of the experiment, with the exception of AMP which showed an almost two-fold rise after 30 minutes of aerobic incubation, followed by a return to the initial value after a further 15 minutes. The reason for this was not clear but may have been due to death of a small number of susceptible cells during the first 30 minutes of the incubation, resulting in hydrolysis of ATP and ADP. Death of about 2-3% of the cells would be enough to account for the rise in AMP, without causing a significant change to ATP or ADP content or to cell morphology. This increase in AMP also contributes to the small but significant drop in the energy charge seen during the first 30 minutes of incubation. The presence of nucleosides and bases from the start of incubation is also probably due to release and hydrolysis of nucleotides from dead and dying cells, which were not completely removed by the washing procedure.

The control concentration of ATP of about 300 nmoles/10<sup>6</sup> cells and the ATP/ADP ratio of 5.8-6.9 are similar to those of series 2 above and compare reasonably well with the results of previous workers as discussed in section 4.1. Also, the energy charge (Atkinson, 1971) of about 0.90 is similar to that obtained by Piper et al., (1982), Geisbuhler et al., (1984), Altschuld et al., (1987), and also to De Young et al. (1989) using Krebs-Henseleit

buffer; although using Joklik medium De Young and colleagues obtained a somewhat higher value of 0.94.

#### **4.2.1 Effect of anoxia on adenine nucleotides and breakdown products**

The effect of anoxia on adenine nucleotides and breakdown products is shown in tables 4.5 and 4.6 with the data for adenine nucleotides also shown in figures 4.1 and 4.2.

Following 30 minutes of anoxia the ATP concentration fell significantly to about 40% of the corresponding time control value, and showed a partial recovery to about 60% of the control value following a subsequent 15 minutes of aerobic incubation (fig 4.1). Anoxia for 30 minutes did not significantly affect the ADP concentration. However, subsequent aerobic incubation for 15 minutes resulted in a significant fall. The concentration of AMP was three-fold higher than the time control after 30 minutes of anoxia, while a subsequent 15 minutes of aerobic incubation resulted in a return to control values. Total adenine nucleotides showed a significant fall to about 65% of the control value following 30 minutes of anoxia, while a subsequent 15 minutes of aerobic incubation resulted in no further change. The fall in adenine nucleotide content during anoxia was balanced by increases in breakdown products, while the partial recovery of ATP following 15

minutes of reoxygenation was accounted for by decreases in ADP and AMP, no net resynthesis of adenine nucleotides occurring. The ATP/ADP ratio fell significantly after 30 minutes of anoxia to about one-third of the control value and following a subsequent 15 minutes of reoxygenation showed partial recovery to about 75% of the control value. The energy charge dropped from about 0.90 to 0.65 following 30 minutes of anoxia while on reoxygenation for 15 minutes it showed an almost complete recovery to 0.86, although this was still significantly lower than the control. The decrease in adenine nucleotides following 30 minutes of anoxia was accounted for mainly by a five-fold increase in the concentration of inosine. The concentration of IMP was two-fold higher than the control, while the increase in mean adenosine concentration, although large, was not statistically significant. On reoxygenation for 15 minutes the IMP concentration returned to the control value while the concentrations of adenosine and inosine showed no further significant changes. There was no significant change in the concentration of hypoxanthine except that following 15 minutes reoxygenation in the presence of ribavirin, it was significantly higher than after anoxia alone or the corresponding time-control. Xanthine content did not change except for a significant increase upon reoxygenation following 30 minutes of anoxia (in the absence of ribavirin). The total concentration of adenine nucleotides plus breakdown products did not change significantly during the experiment.



Legend to tables 4.5 to 4.8 and figures 4.1 to 4.4  
(series 3)

Adult rat ventricular myocytes were isolated as described in section 2.9.1. Each preparation was divided into six equal volume aliquots and subjected to an initial 10 minutes of aerobic incubation at 37°C in a shaking water bath. Ribavirin (7.5 mM) was added at the start of this period. Time control aliquots were then incubated aerobically for 0, 30 and 45 minutes, while other aliquots were subjected to 30 minutes of anoxic incubation with or without a subsequent 15 minutes of aerobic incubation, by the method described in section 2.9.2. At the end of each incubation period aliquots were extracted and analysed for purine compounds as described in section 2.9.3.

Data shown as mean  $\pm$  standard error of five preparations unless stated.

Test of statistical significance was by paired t-test, each aliquot being paired with the appropriate control aliquot from the same myocyte preparation.

\*\* significantly different from t = 0 (p < 0.05)

\* significantly different from corresponding time-control (p < 0.05)

# significantly different from 30 minutes of anoxic incubation (p < 0.05)

**Table 4.5** *Effect of anoxia and ribavirin on adenine nucleotides in isolated rat cardiac myocytes*

nmoles/10<sup>6</sup> cells

| <u>Protocol</u>                          | ATP          | ADP       | AMP        | Tot.<br>AN  | ATP/<br>ADP   | Energy<br>charge |
|--|--------------|-----------|------------|-------------|---------------|------------------|
| 0 min<br>control                         | 313<br>±32   | 46<br>±4  | 9<br>±2    | 368<br>±36  | 6.9<br>±0.5   | 0.91<br>±0.01    |
| 30 min<br>control                        | 306<br>±30   | 54<br>±12 | 17**<br>±2 | 376<br>±41  | 6.1<br>±0.7   | 0.89**<br>±0.01  |
| 45 min<br>control                        | 278<br>±31   | 49<br>±8  | 11<br>±3   | 338<br>±39  | 5.8<br>±0.6   | 0.89<br>±0.01    |
| 30 min anox                              | 129*<br>±21  | 58<br>±7  | 52*<br>±8  | 239*<br>±21 | 2.2*<br>±0.1  | 0.65*<br>±0.04   |
| 30 min anox<br>15 min reox               | 169*<br>±14  | 39#<br>±4 | 10#<br>±1  | 218*<br>±17 | 4.4*#<br>±0.4 | 0.86*#<br>±0.01  |
| 30 min anox<br>15 min reox<br>+ribavirin | 195*#<br>±23 | 43#<br>±7 | 12#<br>±2  | 250*<br>±30 | 4.7*#<br>±0.4 | 0.87*#<br>-      |

**Table 4.6** *Effect of anoxia and ribavirin on adenine nucleotide breakdown products in isolated rat cardiac myocytes*

nmoles/10<sup>6</sup> cells

| <u>Protocol</u>                          | IMP       | ADO              | INO               | HX                | XAN              | Tot. AN<br>+break<br>-down<br>product |
|--|-----------|------------------|-------------------|-------------------|------------------|---------------------------------------|
| 0 min<br>control                         | 3<br>±1   | 12<br>±7<br>n=4  | 14<br>±4<br>n=3   | 35<br>±17<br>n=3  | 24<br>±6<br>n=3  | 456<br>±44                            |
| 30 min<br>control                        | 7<br>±6   | 10<br>±4         | 17<br>±8<br>n=4   | 54<br>±7<br>n=4   | 36<br>±3<br>n=4  | 500<br>±40                            |
| 45 min<br>control                        | 6<br>±3   | 9<br>±5<br>n=4   | 25<br>±13<br>n=3  | 70<br>±5<br>n=3   | 32<br>±7<br>n=3  | 480<br>±43                            |
| 30 min anox                              | 15*<br>±7 | 50<br>±24<br>n=4 | 77*<br>±14<br>n=3 | 72<br>±12<br>n=3  | 29<br>±2<br>n=3  | 482<br>±30                            |
| 30 min anox<br>15 min reox               | 5<br>±3   | 37<br>±30<br>n=4 | 118<br>±45<br>n=3 | 110<br>±15<br>n=3 | 47#<br>±1<br>n=3 | 535<br>±45                            |
| 30 min anox<br>15 min reox<br>+ribavirin | 9#<br>±5  | 40<br>±23<br>n=4 | 114<br>±37<br>n=3 | 93*<br>±1<br>n=3  | 35<br>±9<br>n=3  | 541<br>±47                            |

**Table 4.7** *Effect of anoxia and ribavirin on guanine nucleotides and guanosine in isolated rat cardiac myocytes*

nmoles/10<sup>6</sup> cells

| <u>Protocol</u>                          | GTP            | GDP         | GMP      | GNO                | Total          | GTP/<br>GDP  |
|--|----------------|-------------|----------|--------------------|----------------|--------------|
| 0 min control                            | 15.1<br>±0.9   | 3.0<br>±0.7 | 0.3<br>- | 0.5<br>-<br>n=3    | 18.9<br>±0.9   | 5.7<br>±1.1  |
| 30 min control                           | 14.2<br>±1.2   | 2.9<br>±0.2 | 0.3<br>- | 1.0<br>±0.6<br>n=4 | 18.4<br>±0.9   | 4.9<br>±0.6  |
| 45 min control                           | 14.3<br>±1.7   | 2.4<br>±0.3 | 0.1<br>- | 0.6<br>±0.4<br>n=3 | 17.4<br>±1.2   | 6.5<br>±1.7  |
| 30 min anox                              | 6.2*<br>±0.8   | 3.1<br>±0.2 | 0.5<br>- | 0.7<br>-<br>n=3    | 10.8*<br>±0.9  | 1.9*<br>±0.2 |
| 30 min anox<br>15 min reox               | 9.3*#<br>±0.5  | 2.6<br>±0.2 | 0.2<br>- | 1.7<br>±1.2<br>n=3 | 13.8<br>±0.5   | 3.7#<br>±0.3 |
| 30 min anox<br>15 min reox<br>+ribavirin | 10.2*#<br>±0.8 | 2.1<br>±0.2 | 0.2<br>- | 0.7<br>±0.5<br>n=3 | 13.1*#<br>±0.8 | 4.9#<br>±0.5 |

**Table 4.8** *Correlation between ATP and GTP and nucleotide ratios in isolated rat cardiac myocytes*

correlation between:-

|                               | ATP & GTP | ATP/ADP & GTP/GDP |
|-------------------------------|-----------|-------------------|
| 0 min control                 | 0.6052    | -0.4983           |
| 30 min anoxia                 | 0.7924    | 0.5929            |
| + 15 min reox.                | 0.8355    | 0.1718            |
| + 15 min reox.<br>+ ribavirin | 0.8328    | -0.3627           |

Figure 4.1 *Effect of anoxia and ribavirin on adenine nucleotides in isolated rat cardiac myocytes*

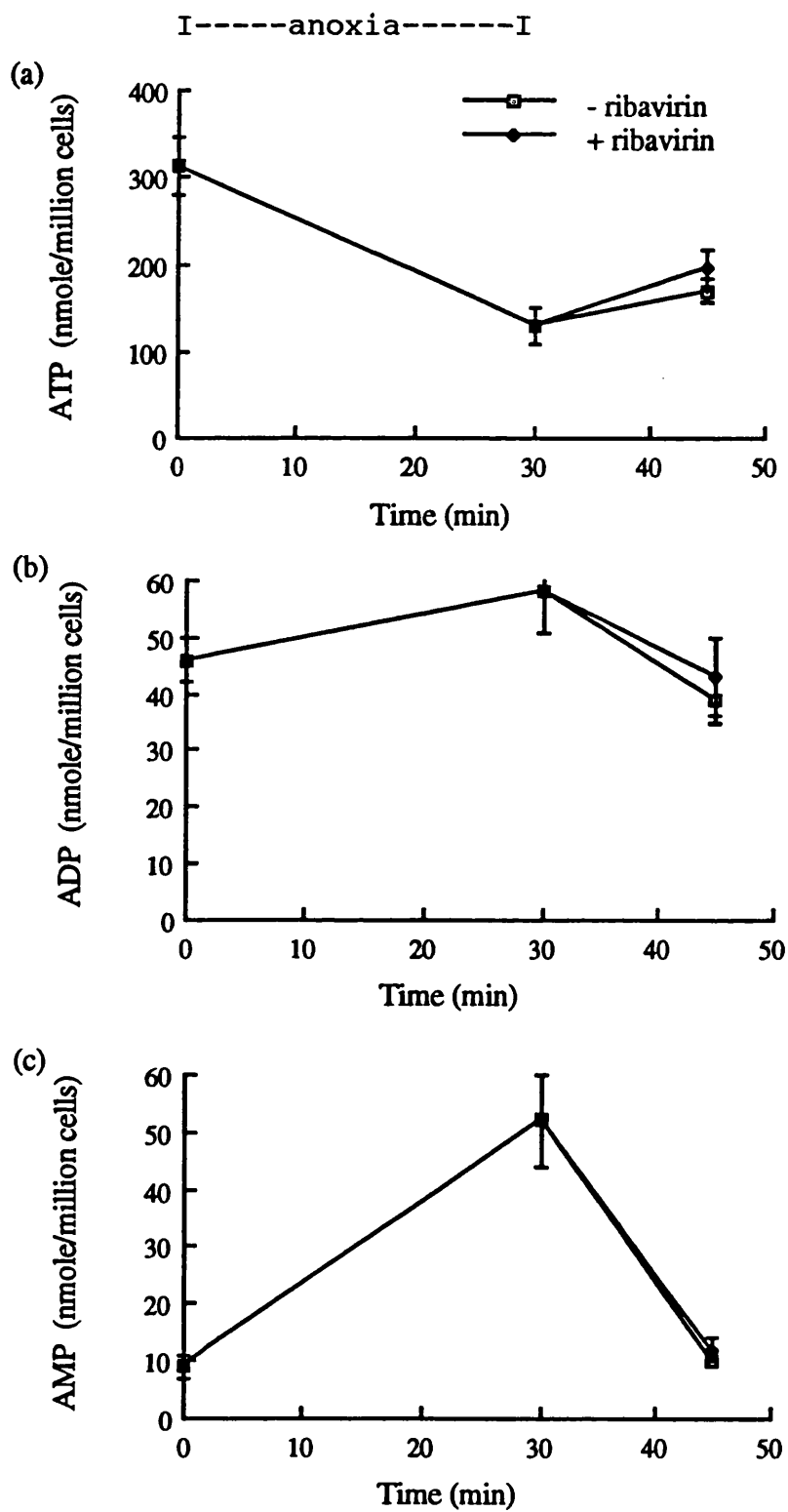

Figure 4.2 Effect of anoxia and ribavirin on total adenine nucleotides and ATP/ADP ratio in isolated rat cardiac myocytes

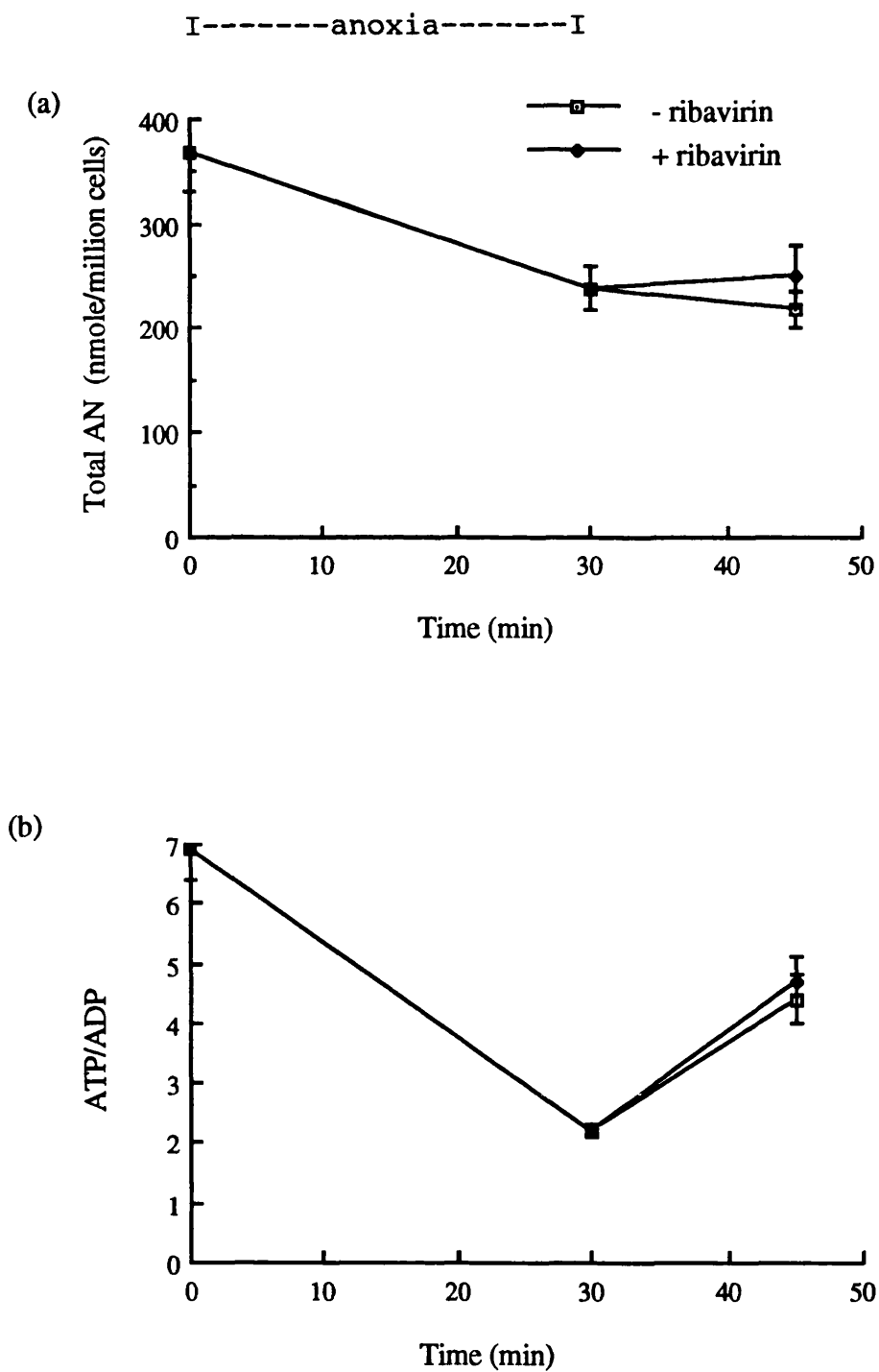
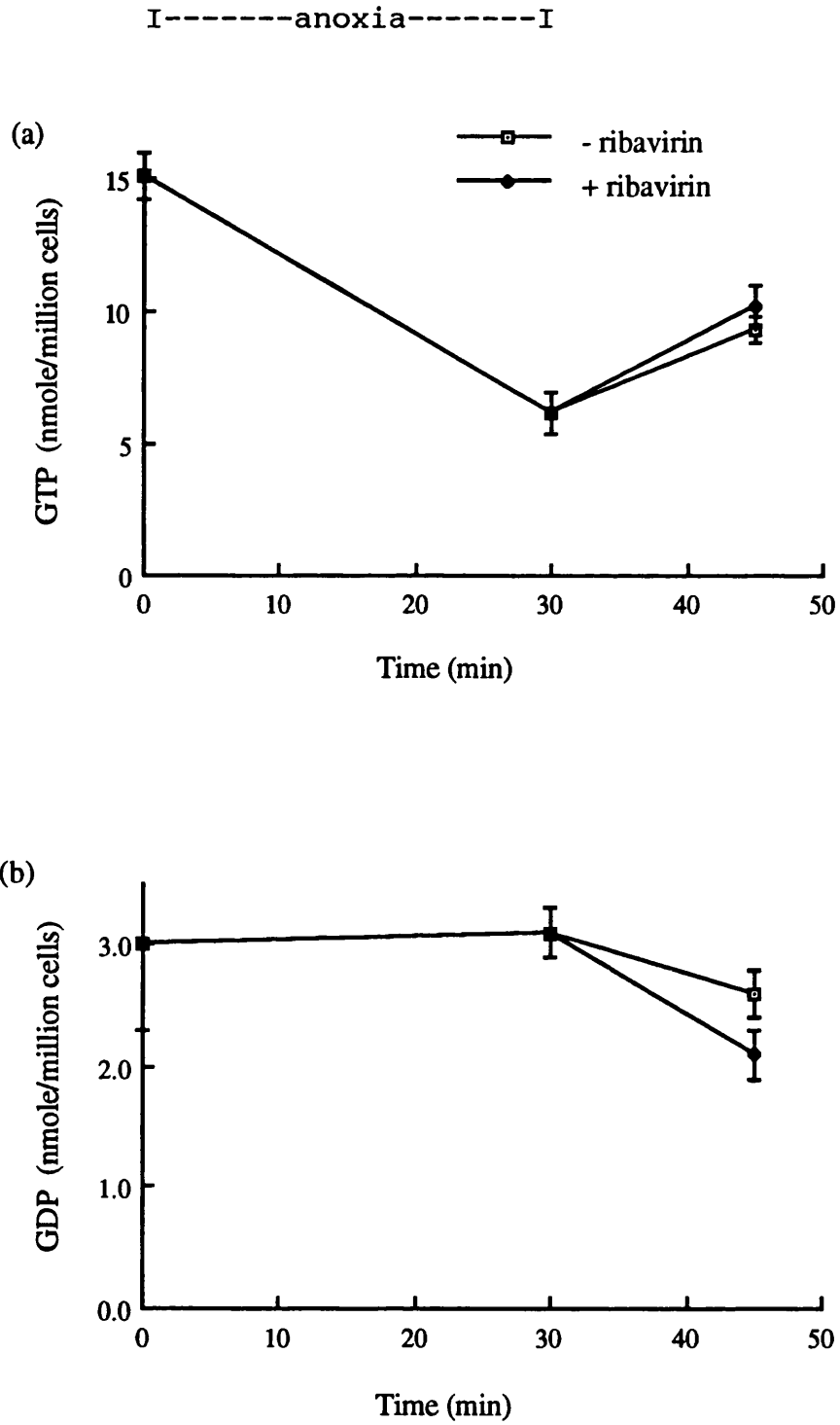
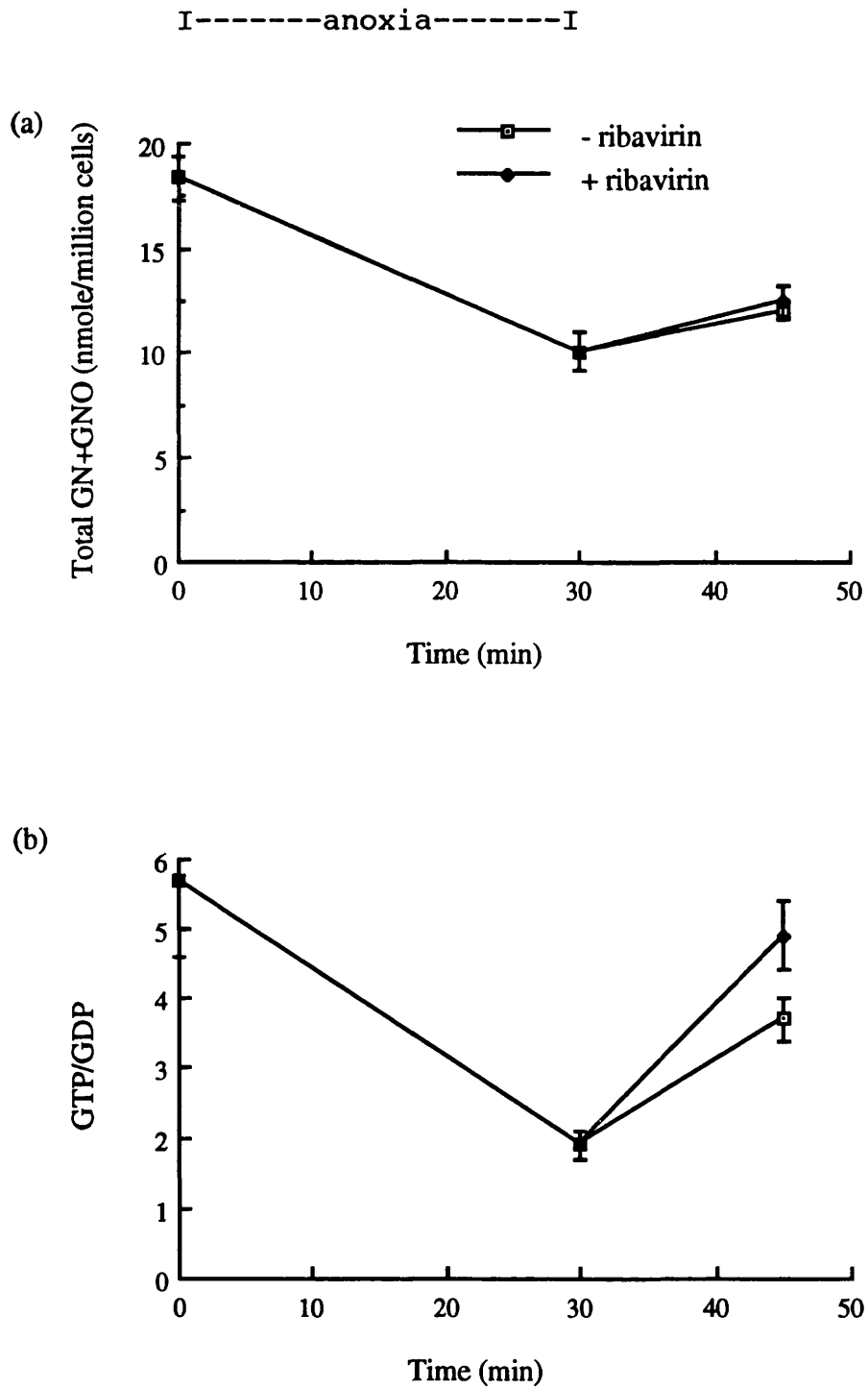

Figure 4.3 Effect of anoxia and ribavirin on guanine nucleotides in isolated rat cardiac myocytes



**Figure 4.4** *Effect of anoxia and ribavirin on total guanine nucleotides plus guanosine and the GTP/GDP ratio in isolated rat cardiac myocytes*





The fall in adenine nucleotide concentration and a corresponding rise in breakdown products has been demonstrated before in isolated myocytes made anoxic for periods up to 45 minutes in the absence of glucose (Hohl et al, 1982; Geisbuhler et al., 1984; Altschuld et al., 1987). However, the loss in adenine nucleotides in these previous studies was much higher, probably because of the absence of glucose which limited the production of ATP by glycolysis. The absence of any net resynthesis of adenine nucleotides in the present study agrees with the previous findings of Dow and colleagues, who showed that rat myocytes appear to have little adenylosuccinate activity (Brown et al., 1985; Dow et al., 1987). However, a net resynthesis of adenine nucleotides following reoxygenation was observed by Geisbuhler et al., (1984) and Altschuld et al., (1987). This was attributed to the utilisation of IMP by the purine nucleotide cycle, as myocytes appear to have limited capacity to re-utilise adenosine via adenosine kinase (Altschuld et al., 1987). As in the present study, earlier studies showed a large drop in energy charge during anoxia, which fully or almost fully recovered following reoxygenation (Hohl et al., 1982; Altschuld et al., 1987).

#### **4.2.2 Effect of anoxia on guanine nucleotides and guanosine**

The effect of anoxia and reoxygenation on guanine

nucleotides and guanosine is shown in table 4.7 and figures 4.3 and 4.4.

The concentration of GTP of 15 nmole/10<sup>6</sup> cells and the GTP/GDP ratio of approximately 6 were maintained during 45 minutes of aerobic incubation. The effect of anoxia on GTP was similar to that on ATP, the concentration of GTP falling to about 45% of the control value after 30 minutes of anoxia and showing a partial recovery to about 65% of the control value after 15 minutes of reoxygenation. The concentration of GDP did not differ significantly from the control value. The GTP/GDP ratio broadly paralleled that of the ATP/ADP ratio, falling to about 40% of the control value after 30 minutes of anoxia and then showing partial recovery to about 60% of the control value after 15 minutes of reoxygenation. Small amounts of GMP (up to 2.5 nmole/10<sup>6</sup> cell) were detected in the HPLC trace of one myocyte preparation. In the other four preparations GMP content was below the level of detection (< 0.5 nmole/10<sup>6</sup> cells), the peaks being absent or too small to quantify. Some GMP (0.4 nmole/10<sup>6</sup> cells) was detected in myocytes by Geisbuhler et al., (1984), but comparison with the present study is difficult as the myocytes isolated by Geisbuhler et al. showed very poor retention of GTP (2.2 nmole/10<sup>6</sup> cells) and 50% of the guanine nucleotide pool was GDP.

Small amounts of guanosine (up to 3.6 nmole/10<sup>6</sup> cell) were detected in some of the preparations, but the data were

insufficient to show any statistically significant changes. Guanine was not detected in any of the preparations.

As for perfused hearts, discrepancies in the content of total guanine compounds were noted. Firstly, the fall in GTP content following 30 minutes of anoxia was not balanced by corresponding increases in breakdown products, resulting in a net decrease in total guanine compounds to about 60% of the control value. However, this could have been due to complete breakdown of guanine compounds to xanthine or uric acid. Secondly, the post-anoxic recovery of GTP, which occurred at a rate of about  $0.2-0.25 \text{ nmole min}^{-1}/10^6 \text{ cells}$ , was not balanced by corresponding decreases in breakdown products. This resulted in an apparent net increase in guanine compounds following 15 minutes of reoxygenation amounting to about  $0.2 \text{ nmole min}^{-1}/10^6 \text{ cells}$ , although curiously this was statistically significant only for the aliquots incubated in the presence of ribavirin.

The correlation between ATP and GTP and the nucleotide ratios is shown in table 4.8. None of the figures were statistically significant, although it is interesting that the highest positive figures were between ATP and GTP following reoxygenation, which is similar to the results for whole hearts where the highest correlation coefficients occurred in reperfused hearts.

#### 4.2.3 Effect of ribavirin on post-anoxic recovery of guanine nucleotides in isolated rat myocytes

The presence of the IMP-dehydrogenase inhibitor ribavirin (7.5 mM) had no effect on the post-anoxic recovery of GTP or on the content of other guanine compounds (figs 4.3 and 4.4 and table 4.7). This was consistent with the earlier results from perfused rat hearts and suggests that synthesis from the adenine nucleotide pool makes no significant contribution to guanine nucleotide recovery following anoxia/ischaemia. Previous work has shown that myocytes, in the presence of 1 mM ribose, incorporate [<sup>3</sup>H]-hypoxanthine into GTP at rates of 0.004 nmole min<sup>-1</sup>/10<sup>6</sup> cells (Brown et al., 1985), or 0.01 nmole min<sup>-1</sup>/10<sup>6</sup> cells (Dow et al., 1987). These rates are only 5% or less of the rate necessary to account for the recovery of GTP in the present study. The rate may be subject to stimulation following anoxia, but the presence of ribavirin (7.5mM) at a concentration far higher than the K<sub>i</sub> for IMP-dehydrogenase made no difference to the GTP recovery, suggesting that this pathway does not make any significant contribution.

As would be expected, ribavirin had no effect on the content of adenine nucleotides or breakdown products following anoxia and reoxygenation (figs 4.1 and 4.2 and tables 4.5 and 4.6).

### 4.3 Conclusions

(1) In isolated myocytes the response to anoxia of guanine nucleotides parallels that of adenine nucleotides as for perfused hearts.

(2) There is an apparent discrepancy in total guanine compounds during anoxia and reoxygenation.

(3) The synthesis of guanine nucleotides from the existing adenine nucleotide pool or by the *de novo* pathway appears not to contribute significantly to the post-anoxic recovery of GTP, by pathways currently known.

(4) The source of post-anoxic guanine nucleotide recovery remains to be identified.

## CHAPTER 5 CONCLUSIONS AND GENERAL DISCUSSION

### 5.1 Conclusions

(1) Following ischaemia in perfused hearts and anoxia in isolated myocytes, changes in concentrations of guanine nucleotides appeared to parallel those of adenine nucleotides under all conditions tested.

(2) Post-ischaemic/anoxic recovery of GTP showed a positive correlation with that of ATP in most cases, although there was not always a concomitant positive correlation between the ATP/ADP and GTP/GDP ratios.

(3) There was a discrepancy in total guanine compounds such that loss and recovery of GTP was apparently not balanced by corresponding changes in breakdown products.

(4) Post-ischaemic/anoxic recovery of guanine nucleotides was unaffected by IMP-dehydrogenase inhibitors, suggesting that neither the existing adenine nucleotide pool and breakdown products nor *de novo* synthesis contributed significantly to this recovery.

(5) Consequent on (3) and (4) above, the source of the post-ischaemic/anoxic guanine nucleotide recovery remains to be identified.

(6) There was no significant correlation between GTP content or GTP/GDP ratio and post-ischaemic response of perfused hearts to adrenaline or carbachol, suggesting that neither the GTP content nor GTP/GDP ratio was a rate-limiting factor in these signal transmission pathways under the conditions imposed.

## 5.2 Guanine nucleotides and ischaemia

In isolated perfused rat hearts, 20 minutes of global no-flow ischaemia resulted in ATP and GTP concentrations falling to about one-third to one-half of their pre-ischaemic (control) value. Complete recovery usually occurred following 10 minutes of reperfusion, the one exception being ATP in series 2. Longer periods of ischaemia, up to 70 minutes, resulted in greater decreases in ATP and GTP content and a progressively lower rate or extent of recovery on reperfusion. Similar parallel changes occurred to the ATP/ADP and GTP/GDP ratios.

The significant positive correlation seen between ATP and GTP content for the reperfused hearts in series 1 and 3 and in the carbachol treated hearts (series 11 and 12) suggests that the extent of post-ischaemic recovery of GTP could be linked to that of ATP via the nucleoside diphosphate kinase reaction. In support of this, a significant positive correlation was seen between the ATP/ADP and GTP/GDP ratios

for series 3 and some of the carbachol treated hearts. However, other perfusions (eg. series 1 and 2) showed no such correlation. This may perhaps have been due to the relatively large errors in measuring the small quantities of GDP ( $\pm 30\%$ ), or due to much of the ADP (and possibly GDP) being bound, so that the measured amounts were not representative of the true free concentration.

There were insufficient breakdown products present at the end of the ischaemic/anoxic period to account for the fall in GTP content, or to act as a source of GTP recovery on reperfusion/reoxygenation. Following 20 minutes of ischaemia in perfused hearts, GDP content showed no significant change from control values, while GMP, guanosine and guanine were not detected in any of the perfusions. Measurement of the perfusate from series 3 hearts showed only inosine to be present. In myocytes, 30 minutes of anoxia resulted in no significant change to GDP, GMP or guanosine content, while guanine was not detected. The GTP could have been metabolised to xanthine or uric acid. However, neither of these latter metabolites could act as a source of GTP recovery. HGPRT has an affinity for xanthine nearly 1000-fold less than for hypoxanthine or guanine (Kelly et al., 1967; Krenitsky et al., 1969), while uric acid is not salvaged by heart (Manfredi and Holmes, 1985). Heart also appears to lack any GMP-deaminase activity, by which GMP could be converted to XMP (Manfredi and Holmes, 1985) and furthermore, no XMP was detected in



the heart extracts.

The lack of effect of IMP-dehydrogenase inhibitors on GTP resynthesis appear to rule out the IMP→XMP→GMP pathway as a route of recovery. Studies with labelled precursors have shown that there is a flux from the existing adenine nucleotide pool or its breakdown products to the guanine nucleotide pool; incorporation of label into guanine nucleotides occurred in rabbit hearts perfused with [<sup>14</sup>C]inosine (Tsuboi and Buckley, 1965), rat hearts perfused with [<sup>14</sup>C]adenosine (Hutchinson et al., 1981), [<sup>14</sup>C]-inosine or hypoxanthine (Harmsen et al., 1984). Similarly, isolated myocytes incubated with [<sup>14</sup>C]hypoxanthine show incorporation of label into GTP (Brown et al., 1985; Dow et al., 1987). However, the flux would be insufficient to account for the post-ischaemic increase in GTP (Harmsen et al., 1984), raising the question as to whether an alternative, as yet unrecognised, pathway is operating.

Previous observations of discrepancies in total adenine nucleotide content have led to the discovery of a novel high energy phosphate derivative oligo-phosphoglyceroyl-ATP (o-PG-ATP) in the TCA-insoluble fraction, which may function as a store or buffer of adenine nucleotides and/or phosphate (Mowbray and Patel, 1991). Given the close parallel between the metabolism of adenine and guanine nucleotides, a guanine nucleotide analogue of o-PG-ATP may exist, which is synthesised in response to ischaemia and

which could account for the discrepancies. As yet there is no evidence of this. As the concentration of guanine nucleotides is only about 5% that of adenine nucleotides, such a compound would presumably have a different role to that of o-PG-ATP, and detecting it would be more of a problem. An experiment to investigate this would be to label the heart or myocyte guanine nucleotide pool by incubating with labelled guanine or guanosine, then introduce ischaemia/anoxia and analyse both the TCA-insoluble and soluble fractions for incorporation of label.

### 5.3 Guanine nucleotides and metabolic regulation

Why should some processes be driven by hydrolysis of GTP instead of ATP? One possible explanation is that GTP drives processes that are not required to operate continuously, so the selective inhibition of GTPases during times of stress would save energy without compromising the short-term survival of the cell. In principle this could be achieved in a number of ways:-

(i) By the independent regulation of adenine and guanine nucleotide concentrations, allowing GTP content to fall while maintaining ATP content.

No evidence of independent regulation of adenine and guanine nucleotides was found in the present study,

although the conditions employed may not have been right for establishing this. Global no-flow ischaemia for a few minutes is probably not a good model for the simulation of heart disease, as it represents a terminal event resulting in sudden death. Regional and/or low-flow ischaemia for a prolonged period might be more relevant to the situation *in vivo* (eg. atherosclerosis), and it would be interesting to see if independent regulation occurs under these conditions. However, the apparent independent regulation of adenine and guanine nucleotides observed previously in this laboratory (Mowbray et al., 1981; 1984), were out of phase oscillations which followed the brief (about 2 minutes) ischaemia occurring during removal and cannulation of the heart.

The nucleoside diphosphate kinase reaction can be inhibited by the substrate MgADP ( $K_i = 20 \mu\text{M}$ ,  $K_m = 100 \mu\text{M}$ ; Colomb et al., 1974), which accumulates in the initial stages of ischaemia. This would prevent any further degradation of ATP via this route, and could explain the rather poor correlation between ATP and GTP content seen in those hearts subjected to ischaemia alone. On reperfusion, the ADP content quickly returned to normal, thus relieving any inhibition and reestablishing the positive correlation between ATP and GTP content seen in the reperfused hearts.

(ii) By having the  $K_m$  for ATPases and GTPases close to the normal intracellular GTP concentration (200-300  $\mu\text{M}$ ), so

that during stress the GTP concentration would fall below this level quickly, thereby inhibiting GTPases, while ATPases continued to function.

All studies to date suggest that the  $K_m$  values for GTPases are much lower than the cellular GTP concentration and are of the order of 1-10  $\mu\text{M}$  (Brandt and Ross, 1985; Thomas, 1988; Mullaney et al., 1988;), making it difficult to see how changes in GTP concentration can affect GTPase activity. Of course, the  $K_m$  values measured *in vitro* do not necessarily reflect the true values *in vivo*, and many GTPases are membrane-bound enzymes which are very sensitive to the experimental conditions (Lefkowitz et al., 1983). However, the absence of any significant correlation between GTP content and post-ischaemic response to drugs reported in section 3.7 suggests that GTP content was not a rate-limiting factor in signal transmission under the conditions employed. Similarly, there was no evidence that the GTP/GDP ratio was a rate-limiting factor in the response to these drugs.

(iii) compartmentation of adenine and guanine nucleotides.

Compartmentation of nucleotides both within cells, and between different cell types within the same organ, may also be important in regulation of GTPase activity. The close association between nucleoside diphosphate kinase and various GTP-binding proteins in cell membranes (Otero,

1990) suggests that the activity of the latter is determined more by the local GTP concentration than whole cell content, as discussed in section 1.4.1.3. Furthermore, the actual free GTP concentration available to the GTPases may be much lower than whole cell measurements suggest, due to binding or compartmentation of GTP (Otero, 1990). The ATP/GTP ratio in myocytes was about 20, while in perfused hearts it was about 10-15, suggesting that myocytes contain relatively less GTP than other cell types in heart. The higher ATP/GTP ratio in myocytes could be an artifact of the myocyte preparation process, whereby only those cells with high ATP content survive the extraction process intact. However, as endothelial cells appear to contain about three times the ATP content of myocytes (Nees and Gerlach, 1983), the present results suggest that GTP is also more highly concentrated in endothelial cells than in myocytes.

(iv) Production or mobilisation of endogenous inhibitors of GTPases during stress.

Various proteins have been isolated which modify the GTPase activity of the Ras superfamily, and are of three main types (Boguski and McCormick, 1993); GTPase activating proteins (GAPs), guanine nucleotide dissociation stimulators (GDSs), and guanine nucleotide dissociation inhibitors (GDIs). The GDIs inhibit GTP/GDP exchange and may also block the action of GAPs (Boguski and McCormick,

1993), but there is no evidence that they are produced or mobilised during stress to inhibit GTPases. It is more likely that they are involved in the integration and crosstalk between different signal transmission pathways.

#### 5.4 Clinical relevance

Following ischaemia, the main problem for cells is the restoration of ATP content, as a reduced ATP concentration is associated with impaired functional recovery and poor long-term survival (Jennings and Steenbergen, 1985). If depletion of GTP results in reduced energy demand by inhibiting non-essential activities, such as signal transmission, then in theory interventions to hasten this depletion (eg. by inhibiting nucleoside diphosphate kinase) may be of benefit. However, against this is the finding that cGMP may have a protective effect against arrhythmias (Billman, 1990). The study reported here does not provide any evidence for such a down-regulation of signal transmission by allowing the GTP content to fall. Furthermore, as the adenine and guanine nucleotide contents vary in parallel, depletion of ATP may mask any effect of GTP reduction.

Previous work has suggested that post-ischaemic rises in cAMP contribute to cardiac arrhythmia (Corr et al., 1978), while cGMP may have a protective effect (Billman, 1990). As

both these second messengers depend on GTP for their production, post-ischaemic decreases in GTP content could either predispose to or protect against arrhythmias, depending on the relative susceptibility of the cyclic nucleotides to GTP content. Based on  $K_m$  values for GTP, it would seem that guanylate cyclase activity ( $K_m$  about 10-100  $\mu\text{M}$ ; Gerzer, et al., 1981) would be more sensitive to reduced GTP content than would G-proteins ( $K_m$  about 0.3  $\mu\text{M}$ ; Brandt and Ross, 1985). However, the data in section 3.7.2 suggests that under the conditions tested, the GTP content does not remain low enough after ischaemia to significantly inhibit cGMP production. Of course, the cGMP content will also depend on the activity of the cGMP-phosphodiesterases, and it is possible that a reduction of guanylate cyclase activity due to a low GTP content could be masked by a corresponding fall in phosphodiesterase activity. Also, the picture is complicated by other factors which may affect G-protein activity after ischaemia (see section 1.4.1.4), and by whether the  $K_m$  values measured *in vitro* bear any relation to the situation *in vivo*.

Of the antidysrhythmic agents in current use, only muscarinic agonists would be susceptible to changes in guanine nucleotide content. Other agents act downstream of second messenger systems by a direct action on ion-channel proteins to bring about a change in the electrical activity of the cell membrane (eg. sodium or calcium-channel blockers, potassium-channel activators). Therefore, based

on the present state of knowledge, it would seem that interventions designed to alter selectively the cellular guanine nucleotide content may not offer any advantage over current treatments for post-ischaemic dysrhythmias.



## References

- Agarwal, R.P. and Parks, R.E. Jr. (1971) *J. Biol. Chem.* 246, 2258-
- Altschuld, R.A., Gamelin, L.M., Kelley, R.E., Lambert, M.R., Apel, L.E. and Brierley, G.P. (1987) *J. Biol. Chem.* 262, 13527-13533.
- Altschuld, R.A., Wenger, W.C., Lamka, K.G., Kindig, O.R., Capen, C.C., Mizuhira, V., Van der Heide, R.S. and Brierley, G.P. (1985) *J. Biol. Chem.* 260, 14325-14334.
- Allen, D.G. and Orchard, C.H. (1987) *Circ. Res.* 60, 153-168.
- Anderson, E.P. (1973) in *The Enzymes* (Boyer, P.D. ed) Vol.9, pp.49-96 Academic Press, New York.
- Atkinson, D.E. (1971) in *Metabolic Pathways Vol.V, Metabolic Regulation* (Vogel, H.J. ed.) pp.1-21, Academic Press, New York.
- Bates, D.J. (1978) PhD. Thesis, Univ. of London.
- Bates, D.J., Perret, D. and Mowbray, J. (1978) *Biochem. J.* 176, 485-493.
- Beavo, J.A., Hansen, R.S., Harrison, S.A., Hurwitz, R.L., Martins, T.J. and Mamby, M.C. (1982) *Mol. Cell. Endocrinol.* 28, 387-410.
- Berne, R.M., Rubio, R., Dobson, J.G. Jr., Curnish, R.R. (1971) *Circ. Res.* 28, (Suppl. I) I115-I119.
- Berry, M.N., Friend, D.S. and Scheuer, J. (1970) *Circ. Res.* 26, 679-687.
- Billman, G.E. (1990) *FASEB J.* 4, 1668-1673.
- Bleehen, N.M. and Fisher, R.B. (1954) *J. Physiol. (Lond.)* 123, 260-276.
- Boguski, M.S. and McCormick, F. (1993) *Nature*, 366, 643-654.
- Bohme, E., Grossman, G., Herz, J., Mulsch, A., Spies, C. and Schultz, G. (1984) *Adv. Cycl. Nucl. & Protein Phos. Res.* 17, 259-266.
- Borgers, M., Schaper, J. and Schaper, W. (1972) *J. Histochem. Cytochem.* 20, 1041-1048.
- Bourne, H.R. and Stryer, L. (1992) *Nature (Lond.)* 358, 541-543.
- Bourne, H.R., Sanders, D.A. and McCormick, F. (1990) *Nature*

(Lond.) 348, 125-132.

Bowditch, J., Brown, A.K., and Dow, J.W. (1985) *Biochim. Biophys. Acta* 844, 119-128.

Brandt, D.R. and Ross, E.M. (1985) *J. Biol. Chem.* 260, 266-272.

Breitweiser, G.E. and Szabo, G. (1988) *J Gen. Physiol.* 91, 469-493.

Brooker, G. (1977) *J. Cyclic Nucl. Res.* 3, 407-413.

Brown, A.K., Raeside, D.L., Bowditch, J. and Dow, J.W. (1985) *Biochem. Biophys. Acta* 845, 469-476.

Brown, B.L., Albano, J.D.M., Ekins, R.P., Sgherzi, A.M. and Tampion, W. (1971) *Biochem. J.* 121, 561-562.

Brown, P.R., Agarwal, R.P., Gell, J., and Parks, R.E. Jr. (1972) *Comp. Biochem. Physiol.* 43B, 891-904.

Buccino, R.J. and Roth, J.S. (1969) *Arch. Biochem. Biophys.* 132, 49-61.

Burgoyne, R.D. (1988) *TIBS* 13, 241-242.

Burgoyne, R.D. and Morgan, A. (1989) *FEBS Lett.* 245, 122-126.

Burton, K. (1956) *Biochem. J.* 62, 315-323.

Cassel, D. and Selinger, Z. (1977) *J. Cycl. Nucl. Res.* 3, 11-22.

Chrismen, T.D., Garbers, D.L., Parks, M.A. and Hardman, J.G. (1975) *J. Biol. Chem.* 250, 374-381.

Cockcroft, S. and Gomperts, B.D. (1985) *Nature (Lond.)* 314, 534-536.

Colomb, M.G., Cheruy, A. and Vignais, P.V. (1969) *Biochemistry* 8, 1926-1939.

Colomb, M.G., Cheruy, A. and Vignais, P.V. (1972) *Biochemistry* 11, 3370-3378.

Colomb, M.G., Cheruy, A. and Vignais, P.V. (1974) *Biochemistry* 13, 2269-2277.

Cook, N.J. and Kaupp, V.B. (1966) *Photobiochem. Photobiophys.* 13, 331-343.

Corbin, J.D., OGREID, O., Miller, J.P., Suva, R.H., Jastorff, B. and Doskeland, S.O. (1986) *J. Biol. Chem.* 261, 1208-1214.

Corr, P.B., Witkowski, F.X. and Sobel, B.E. (1978) *J. Clin. Invest.* 61, 109-119.

- Daughtery, A. and Woodward, B. (1985) *Br. J. Pharmacol.* 85, 621-627.
- De Jong, J.W. and Kalkman, C. (1973) *Biochim. Biophys. Acta* 320, 388-396.
- De Jong, J.W., Keijzer, E., Huizer, T. and Schoutsen, B. (1990) *J. Mol. Cell. Cardiol.* 22, 1065-1070.
- Deuticke, B., Gerlach, E. and Dierkesmann, R. (1966) *Pflugers Arch. Ges. Physiol.* 292, 239-254.
- De Young, M.B., Giannattasis, B. and Scarpa, A. (1989) *Methods in Enzymology* 173, 662-676.
- Diamond, J., Eick, R.E.T. and Trapani, A.J. (1977) *Biochem. Biophys. Res. Comm.* 79, 912-918.
- Dobson, J.G. Jr. and Mayer, S.E. (1973) *Circ. Res.* 23, 412-420.
- Dow, J.W., Bowditch, J., Nigdikar, S.V. and Brown, A.K. (1987) *Cardiovasc. Res.* 21, 188-196.
- Dow, J.W., Harding, N.G.L. and Powell, T. (1981) *Cardiovasc. Res.* 15, 483-514.
- Drummond, R.W. and Sordahl, L.A. (1981) *J. Mol. Cell. Cardiol.* 13, 323-330.
- Fischmeister, R. and Hartzell, H.C. (1987) *J. Physiol. (Lond.)* 387, 453-472.
- Fisher, R.B. and O'Brien, J.A. (1972) *Q. J. Exp. Physiol.* 57, 176-191.
- Fisher, R.B. and Williamson, J.R. (1961) *J. Physiol. (Lond.)* 158, 86-101.
- Flockerzi, V., Speichermann, N. and Hofmann, F. (1978) *J. Biol. Chem.* 253, 3395-3399.
- Franklin, T.J. and Twose, P.A. (1977) *Eur. J. Biochem.* 77, 113-117.
- Fung, B., Hurley, K.K., and Stryer, J.B. (1981) *Proc. Natl. Acad. Sci. U.S.A.* 78, 152-156.
- Furchgott, R.F. and Vanhoutte, P.M. (1989) *FASEB J.* 3, 2007-2018.
- Garbers, D.L. (1979) *J. Biol. Chem.* 254, 240-243.
- Gardner, R.M. and Allen, D.O. (1976) *J. Cycl. Nucl. Res.* 2, 171-178.
- Geisbuhler, T.P., Altschuld, R.A., Trewyn, R.W., Ansel, A.Z., Lamka, K. and Brierley, G.P. (1984) *Circ. Res.* 54, 536-546.

- Geisbuhler, T.P., Johnson, D.A. and Rovetto, M.J. (1987) *Am. J. Physiol.* 253, C645-C651.
- Geisbuhler, T.P., and Rovetto, M.J. (1991) *Pflugers Arch.* 419, 160-165.
- George, W.J., Polson, J.B., O'Toole, A.G. and Goldberg, N.D. (1970) *Proc. Natl. Acad. Sci. U.S.A.* 66, 398-403.
- George, W.J., Wilkerson, R.D. and Kadowitz, P.J. (1973) *J. Pharmacol. Exp. Ther.* 184, 228-235.
- Gerlach, E. and Zimmer, H-G. (1976) *Recent Advances and Studies in Cardiac Structure and Metabolism*, (Harris, P., Bing, R.J. and Fleckenstein, A., eds.) Vol. 7, pp. 121-130, Univ. Park Press, Baltimore.
- Gerzer, R., Brash, A.R. and Hardman, J.G. (1986) *Biochim. Biophys. Acta* 886, 383-389.
- Gerzer, R., Hoffman, F. and Schultz, G. (1981) *Eur. J. Biochem.* 116, 479-486.
- Gerzer, R., Radany, W. and Garbers, D.L. (1982) *Biochem. Biophys. Res. Comm.* 108, 678-686.
- Gilbert, B.E. and Knight, V. (1986) *Antimicrobial Agents and Chemotherapy* 30, 201-205.
- Gilman, A.G. (1970) *Proc. Natl. Acad. Sci. U.S.A.* 67, 305-312.
- Gilman, A.G. (1987) *Ann. Rev. Biochem.* 56, 615-649.
- Glick, M.R., Burus, A.H. and Reddy, W.J. (1974) *Anal. Biochem.* 61, 32-42.
- Goffeau, A., Pedersen, P.L. and Lehninger, A.L. (1967) *J. Biol. Chem.* 242, 1845-1853.
- Green, C.H. and Power, M.H. (1931) *J. Biol. Chem.* 91, 183-202.
- Gudbjarnason, S., Mathes, P. and Ravens, K.G. (1971) *J. Mol. Cell. Cardiol.* 1, 325-339.
- Gudbjarnason, S., Puri, P.S. and Mathes, P. (1971) *J. Mol. Cell. Cardiol.* 2, 253-276.
- Hall, S.W. and Kuhn, H. (1986) *Eur. J. Biochem.* 161, 551-556.
- Harden, T.K., Cotton, C.V., Waldo, G.L., Lutton, J.K. and Perkins, J.P. (1980) *Science* 210, 441-443.
- Harmsen, E., De Tombe, P.P., De Jong, J.W. and Achterberg, P.W. (1984) *Am. J. Physiol.* 246, H37-H43.
- Harrison, S.A., Reifsnnyder, D.H., Gallis, B., Chad, G.G. and

- Beavo, J.A. (1986) *Mol. Pharmacol.* 25, 506-514.
- Hartzell, H.C. and Fischmeister, R. (1986) *Nature (Lond.)* 323, 273-275.
- Haworth, R.A., Goknur, A.B., Warner, T.F. and Berkoff, H.A. (1989) *Cell Calcium* 10, 57-62.
- Higashijima, T., Ferguson, K.M., Smigel, M.D. and Gilman, A.G. (1987a) *J. Biol. Chem.* 262, 757-761.
- Higashijima, T., Ferguson, K.M., Sternweis, P.C., Smigel, M.D. and Gilman, A.G. (1987b) *J. Biol. Chem.* 262, 762-766.
- Hohl, C.M., Ansel, A., Altschuld, R.A. and Brierley, G.P. (1982) *Am. J. Physiol.* 242, H1022-H1030.
- Holmes, E.W., Pehlke, D.M. and Kelley, W.N. (1974) *Biochim. Biophys. Acta* 364, 209-217.
- Horie, M. and Irisawa, H. (1989) *J Physiol. (Lond.)* 408, 313-332.
- Humphrey, S.M., Buckman, J.E. and Holliss, D.G. (1990) *Eur. J. Biochem.* 191, 755-759.
- Humphrey, S.M., Hollis, D.G. and Seelye, R.N. (1985) *Am. J. Physiol.* 248, H644-H651.
- Hutchinson, W.L., Bates, D.J., Perrett, D. and Mowbray, J. (1981) *Biosci. Rep.* 1, 857-863.
- Imoto, Y., Yatini, A., Reeves, J.P., Codina, J., Birnbaumer, L. and Brown, A. (1988) *Am. J. Physiol.* 255, H722-H728.
- Ignarro, L.J. (1990) *Pharmacol. Toxicol.* 67, 1-7.
- Iyengar, R. and Birnbaumer, L. (1982) *Proc. Natl. Acad. Sci. U.S.A.* 79, 5179-5183.
- Jacobus, W.E. and Evans, J.J. (1977) *J. Biol. Chem.* 252, 4232-4241.
- Jefferson, L.S., Wolpert, E.B., Giger, K.E. and Morgan, H.E. (1971) *J. Biol. Chem.* 246, 2171-2178.
- Jennings, R.B., Reimer, K.A., Hill, M.L. and Mayer, S.E. (1981) *Circ. Res.* 49, 892-900.
- Jennings, R.B. and Steenbergen, C. (1985) *Am. J. Physiol.* 47, 727-749.
- Johnson, G.S. and Mukku, V.R. (1979) *J. Biol. Chem.* 254, 95-100.
- Kammermeier, H., Schmidt, P. and Jungling, E. (1982) *J. Mol. Cell. Cardiol.* 14, 267-277.

- Katada, T., Northup, J.K., Bokoch, G.M., Ui, M. and Gilman, A.G. (1984) *J. Biol. Chem.* 259, 3578-3585.
- Katz, A.M. and Hecht, H.H. (1969) *Am. J. Med.* 47, 497-502.
- Katz, L.A., Swain, J.A., Portman, M.A. and Balaban, R.S. (1989) *Am. J. Physiol.* 256, H265-H274.
- Kaziro, Y. (1978) *Biochim. Biophys. Acta* 505, 95-127.
- Kelly, W.N., Rosenbloom, F.M., Henderson, F.J. and Seegmiller, J.E. (1967) *Biochem. Biophys. Res. Comm.* 28, 340-345.
- Kim, D., Lewto, D.L., Graziadei, L., Neer, E.J. and Bar-Sagi, D. (1989) *Nature (Lond.)* 337, 557-560.
- Kimura, H. and Murad, F. (1974) *J. Biol. Chem.* 249, 6910-6916.
- Kimura, H. and Shimada, N. (1988a) *Biochem. Biophys. Res. Comm.* 151, 248-256.
- Kimura, H. and Shimada, N. (1988b) *J. Biol. Chem.* 263, 4647-4653.
- Kleber, A.G. (1983) *Circ. Res.* 52, 442-450.
- Kobayashi, K. and Neely, J.R. (1979) *Circ. Res.* 44, 166-175.
- Kohn, M.C., Achs, M.J. and Garfinkel, D. (1977) *Am. J. Physiol.* 232, R158-R163.
- Krause, E.G. and England, P.J. (1982) *J. Mol. Cell. Cardiol.* 14, 611-613.
- Krebs, H.A. and Henseleit, K. (1932) *Hoppe Seyler's Z. Physiol. Chem.* 210, 33-66.
- Krenitsky, T.A., Papaioannou, R. and Elion, G.B. (1969) *J. Biol. Chem.* 244, 1263-1270.
- Krenitsky, T.A. and Papaioannou, R. (1969) *J. Biol. Chem.* 244, 1271-1277.
- Lamers, J.M.J., Heyliger, C.E., Panagia, V. and Dhalla, N.S. (1983) *Biochim. Biophys. Acta* 742, 568-575.
- Lefkowitz, R.J., Stadel, J.M. and Caron, M.G. (1983) *Ann. Rev. Biochem.* 52, 159-186.
- Lesch, M., Taegtmeyer, H., Peterson, M.B. and Vernick, R. (1976) *Am. J. Physiol.* 230, 120-126.
- Levi, R.C., Alloati, G. and Fischmeister, R. (1989) *Pflugers Archiv.* 413, 685-687.
- Levitzki, A. (1988) *Science* 241, 800-806.

- Lillie, H.W. and Gomperts, B.D. (1992) *Biochem. J.* 288, 181-187.
- Lincoln, T.M. and Corbin, J.D. (1983) *Adv. Cycl. Nucl. Res.* 15, 139-192.
- Lincoln, T.M. and Keely, S.L. (1981) *Biochim. Biophys. Acta* 676, 230-244.
- Lin, S-Y., McKeehan, W.L., Culp, W. and Hardesty, B. (1969) *J. Biol. Chem.* 244, 4340-4350.
- Liu, M.S. and Feinberg, H. (1971) *Am. J. Physiol.* 220, 1242-1248.
- Lowe, D.G., Chang, M.S., Hellmiss, R., Chen, E., Singh, S., Garbers, D.L. and Goeddel, D.V. (1989) *EMBO J.* 8, 1377-1384.
- Maguire, M.H., Lukao, M.C. and Rettie, J.F. (1972) *Biochim. Biophys. Acta* 262, 108-115.
- Manfredi, J.P. and Holmes, E.W. (1985) *Ann. Rev. Physiol.* 47, 691-705.
- Marchetti, C., Carbone, E. and Lux, H.D. (1986) *Pflugers Arch.* 406, 104-111.
- Martins, T.J., Mumby, M.C. and Beavo, J.A. (1982) *J. Biol. Chem.* 257, 1973-1979.
- Mery, P-F., Lohmann, S.M. and Fischmeister, R. (1990) *J. Physiol. (Lond.)* 426, 19P.
- Mery, P-F., Lohmann, S.M., Walter, U. and Fischmeister, R. (1991) *Proc. Natl. Acad. Sci. USA.* 88, 1187-1201.
- Miller, W.H. and Miller, R.L. (1980) *J. Biol. Chem.* 255, 7204-7207.
- Mourad, N. and Parks, R.E. Jr. (1965) *Biochem. Biophys. Res. Comm.* 19, 312-316.
- Mowbray, J. (1969) PhD Thesis, Univ. Edinburgh
- Mowbray, J., Bates, D.J. and Perret, D. (1981) *FEBS. Lett.* 131, 55-59.
- Mowbray, J., Davies, J.A., Bates, D.J. and Jones, C.J. (1975) *Biochem J.* 152, 583-592.
- Mowbray, J. and Ottaway, J.H. (1973) *Eur. J. Biochem.* 36, 362-368.
- Mowbray, J. and Patel, B. (1991) *Biochem. Cell. Biol.* 69, 583-585.
- Mowbray, J., Perret, D. and Bates, D.J. (1984) *Int. J. Biochem.* 16, 889-894.

- Mullaney, J.M., Yu, M., Ghosh, T.K. and Gill, D.L. (1988) Proc. Natl. Acad. Sci. U.S.A. 85, 2499-2503.
- Murphy, E., Freudenrich, C.C. and Lieberman, M. (1991) Ann. Rev. Physiol. 53, 273-287.
- Murray, A.W., Elliot, D.C. and Atkinson, M.R. (1970) Prog. Nucleic Acid Res. Mol. Biol. 10, 87-119.
- Naito, Y. and Lowenstein, J.M. (1981) Biochem. 20, S188-S194.
- Namm, D.H. (1973) Circ. Res. 33, 686-695.
- Nawrath, H. (1976) Nature (Lond.) 262, 509-511.
- Neely, J.R., Rovetto, M.J., Whitmer, J.T. and Morgan, H.E. (1973) Am. J. Physiol. 225, 651-658.
- Neer, E.J. and Clapham, D.E. (1988) Nature (Lond.) 333, 129-134.
- Nees, S., Gerbes, A.L., Willershausen-Zonnchen, B. and Gerlach, E. (1980) in Purine Metabolism in Man III, Biochemical Immunological and Cancer Research (Rapads, A., Watts, R.W.E. and DeBruyn, C.H.M.M. eds.) pp. 25-30 New York Plenum.
- Nees, S. and Gerlach, E. (1983) in Regulatory Function of Adenosine (Berne, R.M., Rall, T.W. and Rubio, R. eds.) pp.347-355, Martinus Nijhoff, The Hague.
- Nickerson, J.A. and Wells, W.W. (1984) J. Biol. Chem. 259, 11297-11304.
- Niroomand, F., Bangert, M., Beyer, T. and Rauch, B. (1992) J. Mol. Cell. Cardiol. 24, 471-475.
- Northup, J.K., Sigel, M.D., Sternweis, P.C. and Gilman, A.G. (1983) J. Biol. Chem. 258, 11369-11376.
- Ohtsuki, K., Ikeuchi, T. and Yakoyama, M. (1986) Biochim. Biophys. Acta 882, 322-330.
- Ono, K., Tareen, F.M., Yoshida, A., Noma, A. and Trautwein, W. (1991) J. Physiol. (Lond.) 446, 150P.
- Ono, K., Tareen, F.M., Yoshida, A. and Noma, A. (1992) J. Physiol. (Lond.) 453, 647-661.
- Ono, K. and Trautwein, W. (1990) Pflugers Archive. 415, suppl. 1 R49.
- Ono, K. and Trautwein, W. (1991) J. Physiol. (Lond.) 443, 387-404.
- Opie, L.H. (1965) J. Physiol. (Lond.) 180, 529-541.
- Otero, A. de S. (1990) Biochem. Pharmacol. 39, 1399-1404.



- Otero, A. de S., Breitweiser, G.E. and Szabo, G. (1988) *Science* 242, 443-445.
- Parks, R.E. Jr. and Agarwal, R.P. (1973) in *The Enzymes* (Boyer, P.D. ed.) Vol 8, pp.307-333, Academic Press, New York.
- Patterson, M.S. and Greene, R.C. (1965) *Anal. Chem.* 37, 854-857.
- Piper, H.M., Probst, I., Schwartz, P., Hutter, F.J. and Spieckermann, P.G. (1982) *J. Mol. Cell. Cardiol.* 14, 397-412.
- Powell, T. and Twist, V.W. (1976) *Biochem. Biophys. Res. Comm.* 72, 327-333.
- Rabkin, S.W., Ohmae, M. and Klass, D.J. (1982) *Arch. Int. Pharmacodyn.* 257, 225-228.
- Rang, H.P. and Dale, M.M. (1987) in *Pharmacology*, pp.119, Churchill Livingstone, London.
- Rahim, Z.H.A., Perrett, D. and Griffiths, J.R. (1976) *FEBS Lett.* 69, 203-206.
- Reimer, K.A. and Jennings, R.B. (1981) *Acta Med. Scand.* 651, 19-27.
- Rizzo, M.T., Tricol, G., Hoffman, R., Jayaram, H.N., Weber, G., Garcia, J.G.N. and English, D. (1990) *Cell. Signal.* 2, 509-519.
- Robishaw, J.D. and Foster, K.A. (1989) *Ann Rev Physiol.* 51, 229-244.
- Rubio, R. and Berne, R.M. (1980) *Am. J. Physiol.* 239, H721-H730.
- Rubio, R., Weidemeier, V.T. and Berne, R.M. (1972) *Am. J. Physiol.* 222, 550-555.
- Sanadi, D.R., Gibson, D.M., Ayengue, P. and Jacob, M. (1956) *J. Biol. Chem.* 218, 505-520.
- Schultz, G., Rosenthal, W. and Heacheler, J. (1990) *Ann. Rev. Physiol.* 52, 275-292.
- Schutz, W., Schrader, J. and Gerlach, E. (1981) *Am. J. Physiol.* 240, H963-H970.
- Siler, J. and Moldave, K. (1969) *Biochim. Biophys. Acta* 195, 138-144.
- Smith, C.M., Henderson, J.F. and Baer, H.P. (1977) *J. Cycl. Nucl. Res.* 3, 347-354.
- Streeter D.G., Witkowski, J.T. Khare, G.P., Sidwell, R.W., Bauer, R.J., Robins, R.K. and Simon, L.N. (1973) *Proc. Natl. Acad. Sci. U.S.A.* 70, 1174-1178.

- Su, Y-F., Harden, T.K. and Perkins, J.P. (1980) *J. Biol. Chem.* 255, 7410-7419.
- Susanni, E.E., Manders, W.T., Knight, D.R., Vatner, D.E., Vatner, S.F. and Homcy, C.J. (1989) *Circ. Res.* 65, 1145-1150.
- Swain, J.L., Hines, J.J., Sabina, R.L. and Holmes, E.W. (1982b) *Circ. Res.* 51, 102-105.
- Swain, J.L., Sabina, R.L., McHale, P.A., Greenfield, J.C. Jr. and Holmes, E.W. (1982a) *Am. J. Physiol.* 242, H818-H826.
- Takai, Y., Nakaya, S., Inoue, M., Kishimata, A., Nishiyama, K., Yamamura, H. and Nishizuka, Y. (1976) *J. Biol. Chem.* 251, 1481-1487.
- Terasaki, W.L. and Appleman, M.M. (1975) *Metabolism* 24, 311-319.
- Thomas, A.P. (1988) *J. Biol. Chem.* 263, 2704-2711.
- Thompson, F.M. and Atkinson, D.E. (1971) *Biochem. Biophys. Res. Comm.* 45, 1581-1585.
- Tilgham, S.M., Hanson, R.W. and Ballard, F.J. (1976) in *Gluconeogenesis: Its Regulation in Mammalian Species*, (Hanson, R.W. and Mehlman, M.A. eds.) pp.47-91, Wiley-Interscience, New York.
- Tovey, K.C., Oldham, K.G. and Whelan, J.A.M. (1974) *Clin. Chim. Acta* 56, 221-234.
- Tremblay, J., Gerzer, R. and Haet, P. (1988) *Adv. Sec. Mess. Phosphoprotein Res.* 22, 319-383.
- Tsuboi, K.K. and Buckley, N.M. (1965) *Circ. Res.* 16, 343-352.
- Tsunoo, A., Yoshii, M. and Narahashi, T. (1986) *Proc. Natl. Acad. Sci. U.S.A.* 83, 9832-9836.
- Utter, M.F. (1951) *J. Biol. Chem.* 188, 847-863.
- Van Bilsen, M., Van der Vusse, G.T., Coumans, W.A., De Groot, M.J.M., Willemsen, P.H.M. and Reneman, R.S. (1989) *Am. J. Physiol.* 257 (1), H47-H54.
- Vary, T.C., Reibel, D.K. and Neely, J.R. (1981) *Ann. Rev. Physiol.* 43, 419-430.
- Vary, T.C., Angelakos, E.T. and Schaffer, S.W. (1979) *Circ. Res.* 45, 218-225.
- Vatner, D.E., Knight, D.R., Shen, Y.T., Thomas, J.X.J., Homcy, C.J. and Vatner, S.F. (1988) *J. Mol. Cell. Cardiol.* 20, 75-82.
- Veech, R.L., Lawson, J.W.R., Cornell, N.W. and Krebs, H.A. (1979) *J. Biol. Chem.* 254, 6538-6547.

- Walton, G. and Gill, G. (1975) *Biochim. Biophys. Acta* 310, 231-245.
- Watanabe, A.M. (1984) Cellular Mechanisms of Muscarinic Regulation of Cardiac Function: in *Nervous Control of Cardiac Function* (Randall, W. ed.) pp. 130-164, New York, Oxford Univ. Press.
- Watanabe, T., Smith, M.M., Robinson, F.W. and Kono, T. (1984) *J. Biol. Chem.* 259, 13117-13122.
- Weiss, J. and Shine, K.I. (1981) *J. Mol. Cell. Cardiol.* 13, 699-704.
- Williamson, J.R. and Corkey, B.E. (1969) in *Methods in Enzymology* (Lowenstein, J.M. ed.) Vol. 13, pp 434-513, Acad. Press, New York.
- Willis, R.C., Carson, D.A. and Seegmiller, J.E. (1978) *Proc. Natl. Acad. Sci. U.S.A.* 75, 3042-3044.
- Willis, R.C. and Seegmiller, J.E. (1979) *Adv. Exp. Med. Biol.* 122B, 237-241.
- Winqvist, R.M., Faison, E.P., Waldan, S.A., Schwartz, K. and Murad, F. (1984) *Proc. Natl. Acad. Sci. U.S.A.* 81, 7661-7664.
- Wollengberger, A., Kraus, E-G. and Heier, G. (1969) *Biochem. Biophys. Res. Comm.* 3, 664-670.
- Wollenberger, A., Ristau, O. and Schoffa, G. (1960) *Pflugers Arch.* 270, 399-412.
- Wyngaarden, J.B. and Ashton, D.M. (1959) *J. Biol. Chem.* 234, 1492-1496.
- Yardin, Y. and Ullrich, A. (1988) *Ann. Rev. Biochem.* 57, 443-478.
- Yatini, A., Hamm, H.E., Codina, J., Mazzoni, M.R., Birnbaumer, L. and Brown, A.M. (1988) *Science* 241, 828-831.
- Zimmer, H-G., Trandelenburg, C., Kammermeier, H. and Gerlach, E. (1973) *Circ. Res.* 32, 635-640.
- Zimmerman, A.N.E., Daems, W., Hulsmann, W.C., Snyder, J., Wisse, W. and Durrer, D. (1967) *Cardiovasc. Res.* 1, 201-209.