

**MOVEMENT AND FEATURE-CHECKING IN KOREAN:  
RELATIVE CLAUSES, TOPICALIZATION, AND CASE-  
MARKING**

Thesis submitted in partial fulfilment  
of the requirements for the degree of

**Doctor of Philosophy**

in The University of London

by

**YOUNG KOOK KIM**

University College London

September, 1997

ProQuest Number: 10055882

All rights reserved

INFORMATION TO ALL USERS

The quality of this reproduction is dependent upon the quality of the copy submitted.

In the unlikely event that the author did not send a complete manuscript and there are missing pages, these will be noted. Also, if material had to be removed, a note will indicate the deletion.

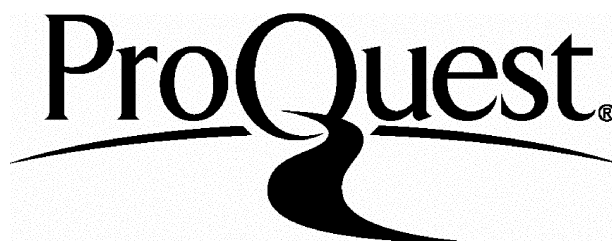

ProQuest 10055882

Published by ProQuest LLC(2016). Copyright of the Dissertation is held by the Author.

All rights reserved.

This work is protected against unauthorized copying under Title 17, United States Code.  
Microform Edition © ProQuest LLC.

ProQuest LLC  
789 East Eisenhower Parkway  
P.O. Box 1346  
Ann Arbor, MI 48106-1346

TO GOD MY FATHER,  
AND MY LOVING PARENTS.

The fear of the Lord is the beginning of wisdom,  
and knowledge of the Holy One is understanding.

(Proverbs 9:10)

## ABSTRACT

The purpose of this thesis is to consider the following phenomena in Korean, within the framework of the minimalist program (Chomsky 1995): (i) the movement of non-restrictive adnominal modifiers, (ii) topicalization, and (iii) Double Nominative Constructions (DNCs).

First of all, following in essence Cinque (1992), I propose that there is a functional category, Agreement Phrase (AgrP) whose specifier position is occupied by the pre-nominal modifiers. I argue for the existence of non-restrictive adnominal modifiers (Relative Clauses (RCs) and pre-nominal adjectives) which move overtly out of the scope of the Determiner in head-final languages like Korean. I claim that the RC or the attributive adjective is base-generated in [Spec,AgrP] due to agreement features (honorific and plural in the case of Korean and Japanese). A restrictive adnominal modifier remains in [Spec,AgrP] due to a FOCUS feature. A non-restrictive modifier, having a NON-FOCUS feature moves to [Spec,DP] whose head  $D^0$  has a NON-FOCUS feature, to check its NON-FOCUS feature.

Secondly, I attempt to unify two contradictory accounts (non-movement or movement) in topicalization in Korean within the minimalist program (Chomsky 1995).

Thirdly, it is my argument that, following much of the literature on this topic, there are three kinds of DNCs in Korean and that the three types of double nominative constructions are derived from a single underlying construction, i.e. the locative construction. The first NP marked Nominative moves to [Spec,Agr<sub>S</sub>P], to check its Case feature by the corresponding Case feature in the head of Agr<sub>S</sub>, while the second NP in DNCs, which originates as the object of the verb, remains inside

VP and has its inherent case feature checked by the verb without moving. In addition, I show that the derivation in the DNCs is the same as that found in English Genitive, Existential and Locative sentences. In connection with DNCs, I claim that in Double Accusative Constructions (DACs) the first NP and the second NP are base-generated independently in different positions from each other, just like in DNCs, but that the second NP in DACs is structurally case-marked in [Spec,Agr<sub>O</sub>P], unlike the second NP in DNCs.

## ACKNOWLEDGEMENTS

First of all, I would like to give many thanks from the bottom of my heart to my supervisor Rita Manzini for her wonderful supervision, constant encouragement, valuable suggestions, and in particular, patience. She has read every word of my thesis thoroughly and patiently. Without her supervision, this thesis could not have been born. She has always given me insightful comments, whenever needed. It has been a true blessing for me to have her as my supervisor. She taught me how to be careful in writing a thesis and organising it.

I wish to express my deep and sincere gratitude to Professor Neil Smith for reading my thesis and commenting on it. The thesis has improved significantly from his insightful comments. In addition, he has been my kind tutor during my study at UCL. I will never forget the understanding and hospitality that he has shown to me. I am also very grateful to Misi Brody for reading an earlier draft of my thesis and commenting on it.

Other teachers in the Linguistics Department have influenced and helped me, both directly and indirectly. I owe much to Professor Richard Hudson and Dr. Hans van de Koot for the academically stimulating atmosphere in Department seminars.

I am especially grateful to my teachers in Hankuk University of Foreign Studies in Seoul. Prof. Yang In-Seok taught me elementary English linguistics, which led me to

enter the linguistic world, and finally, to study for my Ph.D. Prof. Lee Sun-Woo taught me GB syntax. His exciting lectures plunged me into the GB world, and enabled me to meet Andrew Radford and Rita Manzini. Prof. Chung Kuk taught me phonology, which broadened my understanding of 'sound'. I also thank Bob Borsley at University College of North Wales and Andrew Radford at University of Essex. When I studied at Bangor for my M.A., they helped me to deepen my insight in linguistics.

Thanks go to my friends at the Department: Noh Eun-Ju, Kang Hye-Kyung, Kim Kyung-Hee, Ana Madeira, Anne Teng, Stefanie Anyadi, Tanmoy Bhattacharya, Jonathan White, and Maya Arad for their friendship and encouragement. I also deeply appreciate the friendship of my Korean friends at UCL: Kim Young-Soo, Lee Dong-Il, Kim Jin-Il, Choi Hong-Joon, Chung Han-Sung, and Kim Seung-Bum. My special thanks go to Chung Hyunsong for his help in editing my thesis.

Outside UCL, I would like to give my sincerest thanks to Mr. and Mrs. Bae Joong-Myun for their friendship and love, and all the wonderful memories that we have from when we lived together in Nansen Village for three years. I should like to thank Yeon Jae-Hoon and Shin Ji-Young at SOAS, Kim Ye-Jeong at QMWC, and Lee Hye-Kyung at Cambridge. They encouraged and helped me to overcome the emotional frustrations that I experienced living in London. In addition, through seminars, they gave me a lot of comments and ideas. I am also very much indebted to my Korean friends at Korean Calvary Church: Mr. and Mrs. Kim Young-Hoon, Mr. and Mrs. Lee Il-Kwon, Mr. and Mrs. Kwon Oh-Kun, Mr. and Mrs. Yoon Wang-

Guen, Mr. and Mrs. Kim Han-Soo, Mr. and Mrs. Kim Sang-Wook, Mr. and Mrs. Han Dong-Seop, and Mr. and Mrs. Kang Seung-Han. I thank them for the dinners and the spiritual fellowship. Pastor Rhee Seung-Jang, and his family, Samonim, Joseph and Samuel deserve my special gratitude for their loving friendship and concern for my family. I must also say a big thank you to Mr. and Mrs. Shin Dong-Hoon and Mr. and Mrs. Yang Ho-Soon for showing me such hospitality and friendship and, in particular, for taking care of my loving daughter Ji-Yeon while I went to college. I thank Deacon Kim Soo-Hyun for her sincere prayers for my studies. I also thank Rev. Lee Jong-Tae and his wife for their prayers for my thesis and their help in every respect. Mr. and Mrs. Yoo Yeon-Sang deserve my special thanks for their sincere prayers and fellowship. I would like to express my deep thanks to Mr. and Mrs. Kwon Yon-Kyung for their love and prayers. My deep and sincere thanks from my heart go to Mr. Park Hyung-Dong and his wife Yoon Sung-Hye for their love and prayers. I wish to thank Choi Seung-Joon for his proof-reading of my thesis.

I cannot express my thanks to my parents with words. They sacrificed their whole lives for myself and my brothers. They provided us with everything my bothers and I needed while we studied in Seoul, away from our hometown, and encouraged me to pursue my Ph.D. They always supported my decision. My mother has devoted herself to her children's welfare and education. I would simply like to say "Thank you mother and father. I love you".

I thank God for my three brothers, Young-Shik, Young-Chun, and Young-Mo. They supported my studies in London in all aspects. They helped me financially and



spiritually, especially Young-Shik and his wife who deserve my special thanks. They helped my parents and younger brothers on my behalf. Without their help, I could not have finished my studies here in London.

I would also thank my parents-in-law for their love and prayers. They always pray for me and my family. My mother-in-law raised my daughter for six months at Mokpo when my wife and I had difficulties. I am grateful to her for it. My brother-in-law Cho Yang-Yeon also deserves my thanks for his help. Many thanks must go to my uncle and aunt Shin Woo-Seok and Suh Kwee-Rye for their love and prayers. They looked after me for two years during my university life in Seoul. I take this opportunity to express my deepest gratitude for their love. Without their help, I could not have studied in Seoul.

Finally, I have to express my special thanks to two very special persons, my wife, Cho Hyeon-Mi and my daughter, Ji-Yeon. Throughout my research for a Ph.D., my wife supported me spiritually and materially. My wife has worked in a bank for two years. I thank her for her love, perseverance and support. My daughter Ji-Yeon gave and gives me so much joy. The presence of my daughter is my pleasure and encouragement. Once again, I thank my wife and daughter.

Above all, however, God is the One who has my ultimate gratitude. Without His love and mercy, my thesis and I would not exist. I praise God the Father, the Son, and the Holy Spirit for all the blessings bestowed on me and my family.

<b>ABSTRACT</b> -----	3
<b>ACKNOWLEDGEMENTS</b> -----	5
<b>TABLE OF CONTENTS</b> -----	9
<b>ABBREVIATIONS</b> -----	13
<b>CHAPTER 1. INTRODUCTION</b> -----	14
1.1. Outline of the Thesis-----	14
1.2. The Minimalist Program-----	17
1.2.1. Background-----	17
1.2.2. Elimination of D- and S-Structure-----	18
1.2.2.1. Elimination of D-Structure-----	18
1.2.2.2. Elimination of S-Structure-----	19
1.2.3. Economy Principle-----	24
1.2.3.1. Full Interpretation-----	24
1.2.3.2. Greed and Last Resort -----	25
1.2.3.3. Shortest Link, Fewest Steps, and Procrastinate-----	26
1.2.4. Definition of Checking Configuration-----	31
1.2.5. Numeration and Select-----	36
1.2.6. Merge-----	37
1.2.7. Move-----	38
1.2.7.1. Movement and Uniformity Condition-----	39
1.2.7.2. Attract-F-----	39
1.2.7.3. Interpretability of Features-----	42
1.2.7.4. MLC and Attract- $\alpha$ -----	42
1.2.8. Bare Phrase Structure-----	44
1.2.8.1. Elimination of Agr-----	49
1.2.9. Feature-Checking and Case-Marking-----	52
1.2.10. Feature-Driven Movement and Word Order-----	53
1.2.10.1. Word Order and Kayne's LCA-----	54
1.2.11. Summary-----	56
<b>CHAPTER 2. AGREEMENT PHRASE IN DP</b> -----	59
2.1. The DP-Hypothesis and the Fundamental Structure of the Clause-----	59
2.1.1. Parallel Structure of DP and IP-----	60
2.1.2. Clause Structure in Korean-----	61
2.1.3. The Topic and Focus Positions in a Clause-----	63

2.1.4.	The Topic and Focus positions in the DP-Structure-----	67
2.1.5.	Functional Categories between DP and NP-----	69
2.2.	Functional Categories in Noun Phrases in Korean-----	70
2.2.1.	Honorific and Plural Agreement in Clauses-----	72
2.2.2.	Honorific and Plural Agreement in Noun Phrases-----	74
2.3.	The Position of Adnominal Modifiers-----	77
2.3.1.	The Nature of Pre-nominal Adjectives and RCs-----	77
2.3.2.	The Nature of AM Markers-----	79
2.3.2.1.	Aspect-----	80
2.3.2.2.	The Totality View of Perfectivity-----	81
2.3.2.3.	Aspect in RCs and Pre-nominal Adjectives-----	82
2.3.3.	The Structure of Pre-nominal Adjectives and RCs-----	84
2.4.	The Movement of the External Genitive Argument-----	85
2.5.	The Movement of N <sup>0</sup> in Num-CI Constructions-----	87
2.5.1.	The Movement of the Head Noun in Korean Num-CI Constructions-----	87

**CHAPTER 3. THE MOVEMENT OF NON-RESTRICTIVE  
ADNOMINAL MODIFIERS-----95**

3.1.	The Notion of Restrictiveness-----	96
3.1.1.	The Distinction between an RRC and an NRC in English-----	97
3.1.2.	The Distinction between an RRC and an NRC in Korean-----	100
3.1.3.	The Contrast between an RA and an NA in Korean-----	103
3.1.4.	The Contrast between an RA and an NA in English-----	107
3.2.	The Movement of the NAM to the Pre-Determiner Position-----	108
3.3.	The Structure of Relative Clauses-----	109
3.3.1.	Previous Analyses-----	109
3.3.2.	Kayne's (1994) Analysis-----	114
3.3.2.1.	The [D <sup>0</sup> CP] Structure-----	114
3.3.2.1.1.	Relative Pronouns as Determiners--	116
3.3.2.2.	N-Final Relative Clauses-----	120
3.3.2.3.	Structural Difference between RRCs and NRCs-----	120
3.3.2.4.	The Structure of NRCs-----	121
3.3.3.	Some Problems with Kayne's [D <sup>0</sup> CP] Structure-----	122
3.3.4.	The Structure of RCs in an N-Final Language-----	123
3.4.	Focus and Non-Focus Features in Adnominal Modifiers-----	125

3.5.	IHRCs-----	129
3.5.1.	The Structure of IHRCs-----	131
3.5.2.	The Position of 'kes' in IHRCs-----	134
3.5.2.1.	'Kes' as a Pro-Form in IHRCs-----	135
3.5.3.	IHRCs as Non-restrictive Relative Clauses-----	139
 <b>CHAPTER 4. TOPICALIZATION-----</b>		<b>142</b>
4.1.	Identification of Topic in Korean-----	144
4.1.1.	The Notion of Topics with Reference to Relatives-----	145
4.1.2.	Contrast between Topic Subject and Nominative Subject-----	146
4.1.3.	Topic and Contrastive Focus-----	148
4.2.	Previous Analyses in GB Framework-----	149
4.2.1.	Topicalization in English-----	149
4.2.2.	Topicalization in Korean-----	151
4.2.2.1.	Movement Analysis-----	151
4.2.2.2.	Base-Generation Analysis-----	152
4.2.2.3.	Saturation or Licensing Analysis-----	157
4.3.	Topicalization within the Framework of the Minimalist Program-----	159
4.3.1.	Topic Constructions within the Feature-Checking Theory-----	159
4.3.2.	The Position of Topic Phrases-----	160
4.4.	Why Not a topic in an RC ?-----	166
4.4.1.	No Double Topics in a Clause-----	166
4.4.2.	No Topic in a Relative Clause-----	167
 <b>CHAPTER 5. CASE-MARKING IN DOUBLE NOMINATIVE CONSTRUCTIONS-----</b>		<b>170</b>
5.1.	Double Nominative Constructions-----	170
5.2.	The Analysis of Verbs Allowing Double Nominative-----	172
5.2.1.	The Notion of Intransitive Verbs-----	172
5.2.2.	Korean Data-----	173
5.3.	Case-Checking-----	176
5.3.1.	Direct Case-Checking or Indirect Case-Checking ?-----	176
5.3.2.	A Problem for the Indirect Case-Assignment Hypothesis-----	176
5.3.3.	Evidence for the Direct Case-Assignment Hypothesis-----	179

5.3.4. The Analysis of Locative Existentials and Ergative Constructions-----	181
5.3.5. Case Theory for Double Nominative Constructions-----	187
5.3.5.1. Inherent Case-----	188
5.3.5.2. The Nature of Inherent Case Marked NPs-----	189
5.3.5.3. Word Order in DNCs-----	192
5.3.6. The Analysis of Experiencer Constructions-----	193
5.3.7. The Analysis of Possessive Constructions-----	195
5.3.7.1 Evidence from Honorification-----	197
5.4. Double Accusative Constructions (DACs)-----	199

<b>BIBLIOGRAPHY-----</b>	<b>205</b>
--------------------------	------------

## ABBREVIATIONS

The following abbreviations are used in the glosses of the language data.

Acc	Accusative
Adj	Adjective
AM	Adnominal Modifying / Adnominal modifying Marker
App	Apparent
Cl	Classifier
Co	Copular
Comp	Complementizer
Dat	Dative
Det	Determiner
Dec	Declarative
Dem	Demonstrative
Fem	Feminine
Fut	Future
Gen	Genitive
Hon	Honorific
Imp	Imperative
Impf	Imperfective
Loc	Locative
Masc	Masculine
Mod	Modal
Neg	Negative
Nom	Nominative
Num	Numeral
Numb	Number
Obl	Oblique
Perf	Perfective
Pl	Plural
Prog	Progressive
Prst	Present
Pst	Past
Psv	Passive
Q	Question
Rep	Reportive
Sg	Singular
Sus	Suspicion
Top	Topic

# CHAPTER 1

## INTRODUCTION

### 1.1. Outline of the Thesis

My purpose in this thesis is to explore movements within DP, topicalization, and case-marking in Double Nominative Constructions (DNCs) in Korean, in terms of feature-checking within the framework of the minimalist program (Chomsky 1995).

The general assumption in the thesis is that movement should obey Last Resort. First of all, it is my contention that the external subject (genitive) argument in nominal constructions moves to the pre-determiner position, [Spec,DP], to check its genitive case feature. Furthermore the head  $N^0$  itself in Numeral-Classifier (Num-Cl) constructions moves to  $D^0$  due to its specific feature.

Secondly, I argue that there exists a distinction in word order and interpretation between the Restrictive Adnominal Modifier (RAM) and the Non-restrictive Adnominal Modifier (NAM) in both English and Korean. The NAM in both languages has the same underlying word order as the RAM, but only the NAM gets out of its original position and moves to the pre-determiner position. The movement of the NAM to the pre-determiner position is done in overt syntax in Korean but in LF in English.

Thirdly, I propose that the RAM has a FOCUS feature while the NAM has a NON-FOCUS feature, and that the movement of the NAM to the pre-determiner position is due to the NON-FOCUS feature.

Fourthly, I claim that a topic in Korean may be inserted into [Spec,MP] directly from the lexicon by 'Merge', or be moved from its base-generated position inside VP to [Spec,MP] by 'Move'.

Finally, it is my argument that there are three kinds of DNCs in Korean, and that the three types of DNCs are derived from a single underlying construction, i.e. the locative construction. The first NP marked Nominative moves to [Spec,Agr<sub>S</sub>P], to check its case feature by a corresponding case feature borne by the verb adjoined to the head of Agr<sub>S</sub>P (in Korean the verb is covertly adjoined to Agr<sub>S</sub> through Agr<sub>O</sub>). The second NP in DNCs originates as the object of the verb, remaining inside VP, and due to its inherent case feature does not move. In addition, I show that the derivation in the DNCs is the same as that found in English Genitive, Existential and Locative sentences.

The thesis is organised as follows. The rest of this chapter reviews the theoretical background, namely, the minimalist program of Chomsky (1995). In Chapter 2, I discuss the structure of the Korean DP and the movements within it. In Sections 2.1 and 2.2, I adopt the idea that there is an intermediate functional category called AgrP (or AGRP) between DP and NP. I argue that the honorific and plural feature agreement between adnominal modifiers (such as pre-nominal adjectives and RCs) and their head nominal takes place in AgrP. The modifiers appear in [Spec,AgrP], checking their agreement features against the corresponding



features borne by the noun head adjoined to the head of AgrP. Sections 2.3 and 2.4 are concerned with the movements within DP.

Chapter 3 is devoted to some discussions of RRCs and NRCs, including Internally Headed Relative Clauses (IHRCs). Based on Jaggar's (1997) claim that the restrictive RC has a FOCUS form of INFL and the non-restrictive RC has a NON-FOCUS form in Hausa, an Afroasiatic language, I suggest that the RRC has a FOCUS feature, and the NRC has a NON-FOCUS feature, respectively. I propose that the movement of the NRC to the pre-determiner position from its original position is due to the NON-FOCUS feature. The movement of the NRC to [Spec,DP] takes place in overt syntax in Korean and in LF in English. This movement is accounted for in terms of the feature-checking assumed in Chomsky (1995).

Chapter 4 examines topicalization with reference to English topicalization in terms of Move and Merge (feature-checking).

Chapter 5 is concerned with the Double Nominative Constructions (DNCs) in Korean. In this Chapter, I argue that these DNCs are derived from the locative construction, showing that the derivation in Korean DNCs is the same as that found in English Genitive, Existential and Locative sentences. With respect to case-marking in DNCs, I propose that the first NP marked nominative derives from the locative position and moves into [Spec,Agr<sub>3</sub>P] to check its nominative case feature, and the second NP marked nominative remains within VP due to its inherent Case.

## 1.2. The Minimalist Program

### 1.2.1. Background

In this Section, I discuss the theoretical background to my thesis, the minimalist program (MP) (Chomsky 1995)

In Government-Binding (GB) theories (Chomsky 1981, 1986a and references cited there), operations such as Move- $\alpha$  can apply freely. Ungrammatical derivations are ruled out by conditions that apply at D- and S-Structure and at LF and PF. Two of the major changes in the minimalist program (Chomsky 1995) are these: (i) constituents do not move freely but move only under Last Resort, and (ii) the minimalist program recognises only two interface levels of representation- LF and PF.

These changes lead to simplification of the grammar by eliminating D- and S-Structure and the principles that might have applied at these levels. Indeed, the four levels of representation are reduced to two interface levels, LF and PF, which are linked to grammar-external systems, Conceptual-Intentional (C-I) and Articulatory-Perceptual (A-P), respectively. The computational system projects lexical items from the lexicon onto X-bar trees in compliance with the X-bar theory, and carries out the operation, Move- $\alpha$ , until SPELL-OUT, from which the derivations of the PF and LF- representations diverge. This means that the interface levels LF and PF are derivationally<sup>1</sup> derived. SPELL-OUT is not a syntactic level of representation, and the operation, Move- $\alpha$ , may continue after SPELL-OUT, as illustrated in (1).

---

<sup>1</sup> Contrary to Chomsky (1995), Brody (1995, pp. 20-21) argues that the interface level LF is not derivational but representational, and Johnson and Lappin (1997) have reservations about Chomsky (1995), arguing that the economy-based model of the MP can be replaced with a local model like constraint-based grammar.

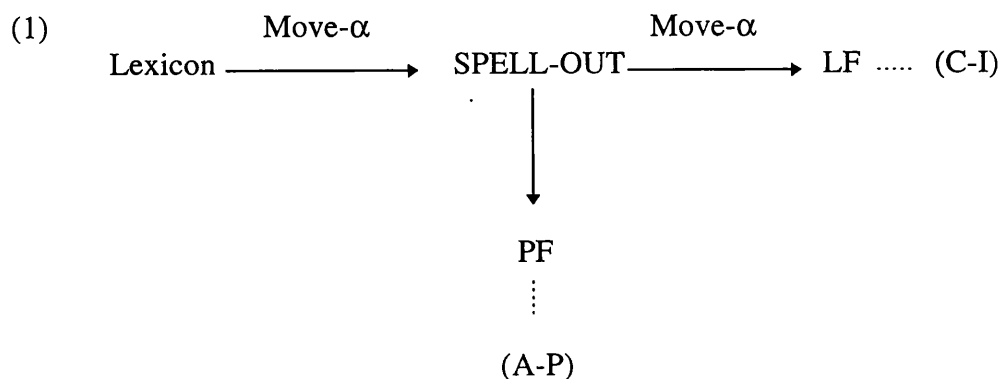

## 1.2.2. Elimination of D- and S- Structure

### 1.2.2.1. Elimination of D-Structure

Some principles of UG such as the Projection Principle and the Theta-Criterion apply at D-Structure. Some other principles of UG, like Binding theory, Case theory, etc., apply at S-Structure. If D-Structure and S-Structure are eliminated from UG, all the principles applying at these two levels must be captured at the two interface levels LF and PF or in other ways. Let us turn to how those effects and explanations applying at the two internal interface levels can be accommodated into the minimalist program.

Chomsky (1995) raises some questions concerning the postulation of D-Structure by presenting an adjectival construction like (2). The example in (2) is reproduced from Chomsky (1995, p. 188).

- (2) a. \_\_\_\_ is easy to please ----- D-Structure
- b. John is easy [<sub>CP</sub> Op<sub>i</sub> [<sub>IP</sub> PRO to please t<sub>i</sub>]] ----- S-Structure

The problem is that John in (2b) must be inserted after D-Structure. According to the Theta-Criterion, the matrix subject position in (2) is a non-theta position and therefore no argument can be inserted into the subject position at D-Structure. As Chomsky (1981) proposes, the only possible way is that John is inserted during the course of the derivation and assigned its theta-role only at LF. However, this proposal violates the idea that all lexical items must be inserted at D-Structure by definition. Since the assumption of D-Structure does not explain examples like (2), Chomsky (1995) is led to do away with D-Structure.

#### 1.2.2.2. Elimination of S-Structure

In the GB framework, Case theory<sup>2</sup> and Binding theory are assumed to apply at S-Structure. However, in the minimalist program, which dispenses with S-Structure as well as D-Structure, Case theory and Binding theory hold at LF.

Consider the example in (3), from Chomsky (1995, p. 205).

(3) John wondered [which picture of himself]<sub>i</sub> Bill saw t<sub>i</sub>

If the Binding theory applies at D-Structure, we cannot explain why John can be the antecedent of the reflexive himself, since the antecedent Bill is closer, as illustrated in (4):

(4) John wondered [Bill saw which picture of himself]

---

<sup>2</sup> See Section 1.2.9. for how Case theory can be accounted for in terms of feature-checking at LF.

This supports the view that the Binding Theory must apply at S-Structure.

Let us then turn to the assumption that the binding conditions apply at LF. The LF representation of (5) will be (6). In multiple wh-questions the wh-phrase remaining in situ must move into [Spec,CP] in LF (e.g. which picture of himself in (5) adjoins to who at LF as in (6)). The examples in (5) and (6) are reproduced from Chomsky (1995, p. 205).

(5) John wondered who saw which picture of himself ----- S-Structure

(6) John wondered [[which picture of himself]<sub>i</sub> who<sub>j</sub> [<sub>t<sub>j</sub></sub> saw t<sub>i</sub>]] ----- LF

In (5) himself is bound by who. However, if the binding theory holds at LF, the reflexive himself is incorrectly predicted to be bound by John, the subject of the matrix clause. To avoid the unwanted result, we have to say once again that the Binding Theory must apply at S-Structure.

However, the following example poses a problem for the argument that the Binding Theory must apply at S-Structure. The example in (7) comes from Cook and Newson (1997).

(7) [which picture of himself]<sub>i</sub> did Jane say Peter lost t<sub>i</sub> ----- S-Structure

The antecedent of himself is Peter the subject of the embedded clause. However, at S-Structure we cannot explain how the reflexive himself can be bound by Peter which does not c-command it. The example in (7) seems to be a counter example to

the argument that Binding Theory must hold at S-Structure. The postulation of reconstruction resolves this situation. The notion of reconstruction should be understood within the Copying Theory of Movement assumed in Chomsky (1995). In the minimalist theory, movement is explained in terms of copying theory. If an element moves somewhere, it leaves behind an identical copy, as illustrated in (8) (example from Chomsky (1995, p.202)).

- (8) a. Did John live [in which house]  
b. [ in which house ] did John live [in which house ]

The copied element in the original position in which house is deleted (or invisible) in PF but visible in LF.

Let us consider how the theory of reconstruction<sup>3</sup> works in the minimalist program (Chomsky 1995, 202-212). In a pied-piping wh-construction like (8), for convergence at LF, only the wh-material can appear in [Spec,CP]; the remaining non-wh-material should therefore be present in its original position. In other words, under the copying theory, non-wh-material in [Spec,CP] is deleted and only the wh-element remains; non-wh-material appears in the original position where the wh-phrase deletes. Chomsky (1995, p.202) argues that then the LF structure for (8b) is as in (9).

---

<sup>3</sup> Traditional reconstruction without the copying theory of movement requires the whole wh-phrase to be put back in its original position and only the wh-word to move again to a wh-position (Spec,CP) at LF; whence the name of 'reconstruction'.

(9) [<sub>CP</sub> [ wh-X ] did [<sub>IP</sub> John live [in X house ]]]

Let us extend reconstruction to the sentence in (10) (from Chomsky 1995, p. 206), whose structure is (11) under the copying theory.

(10) John<sub>i</sub> wondered [which picture of himself<sub>i/j</sub> ]<sub>k</sub> [Bill<sub>j</sub> took t<sub>k</sub> ] ?

(11) John wondered [which picture of himself] Bill took [which picture of himself]

If the LF structure for (10) is (12), Bill and himself are coreferential.

(12) John wondered [<sub>CP</sub> [wh-X] [<sub>IP</sub> Bill<sub>i</sub> took [ X picture of himself<sub>i</sub>]]]

In contrast, if the LF structure is (13), John and himself are coreferential.

(13) John wondered [<sub>CP</sub> [wh-X, X= picture of himself] [<sub>IP</sub> Bill took X]]]

Given the copying theory of movement and reconstruction which are assumed in Chomsky (1995, p.200-212), the LF structure for (7) will then be as in (14) below:

(14) [which x [Jane said Peter lost [x picture of himself]]]

Peter in the embedded clause can bind its reflexive himself, as desired. This LF reconstruction operation together with the copying theory of movement therefore

rescues an example like (7) for Binding Theory. If Binding Theory applies at S-Structure as in the case of (7), we cannot account for why Peter can be the antecedent for the reflexive himself. This implies that Binding Theory applies at LF. A contradiction now arises: an example like (5) supports the conclusion that Binding Theory must apply at S-Structure while an example like (7) suggests that Binding Theory must apply at LF. As a way out of this dilemma, Chomsky (1995) assumes a different LF structure for (5): the legitimate LF structure for (5) is not the one given in (6) but the following in (15) (example from Cook and Newson (1997)).

(15) John wondered [which<sub>i</sub> [who<sub>j</sub> [t<sub>j</sub> liked [t<sub>i</sub> picture of himself]]]]

This analysis is possible under the view of reconstruction discussed above, requiring only wh-elements like which and not the whole wh-phrase like which picture of himself to be present in [Spec,CP]; the rest of the wh-phrase, i.e. the non-wh material picture of himself is in its original position, as illustrated in (15). The LF structure assumed in (15) shows that the reflexive himself cannot be bound, as wanted, by John.

If this analysis is adopted, Binding Theory can hold at LF and the argument that Binding Theory must apply at S-Structure can be eliminated.

In summary, D-Structure and S-Structure can be eliminated from the grammar in accordance with the proposals of minimalism.



### **1.2.3. Economy Principle**

In GB theory, a lot of theories or principles such as Case Theory, Binding Theory, Government Theory, Theta theory, Control Theory, Empty Category Principle (ECP), Extended Projection Principle (EPP), etc. are introduced to account for the observed data. However, the Minimalist Program (Chomsky 1995) attempts to reduce most principles to a Principle of Economy, which requires the operation of grammar to be as economical as possible. This Economy Principle applies to both representation and derivation (Chomsky 1995, p.27).

For representations, the Economy Principle reduces to Full Interpretation, which states that there can be no superfluous symbols in representations. For derivation, it is interpreted essentially in terms of Last Resort which states that there can be no superfluous steps in derivations (Chomsky 1995, p. 27-28).

#### **1.2.3.1. Full Interpretation**

Full Interpretation (FI) applies at the interface levels LF and PF. According to FI (Chomsky 1995), the interface representations may contain no symbol that is not interpretable for the C-I and A-P systems at LF and PF respectively. Morphosyntactic features such as “Case-”(Nom, Acc,...) are not externally interpretable symbols, and hence they cannot appear in well-formed interface representations by the FI principle.

#### (16) Full Interpretation

Every element at LF and PF must be a legitimate object for interpretation and properly interpreted.

Let us consider how the economy principle FI works in a sentence like (17)<sup>4</sup>.

(17) \* There seems to [a strange lady] that it is raining outside

In (17) a strange lady has its case properties satisfied internally to PP; so it is not permitted to raise. At LF the case feature on the matrix I, which cannot be checked by there, still remains, violating the FI and resulting in an ungrammatical representation.

### 1.2.3.2. Greed and Last Resort

From the viewpoint of an element  $\alpha$  which is to move, Last Resort can be stated in the form of Greed (Chomsky 1995, p. 261), as in (18):

(18) Move- $\alpha$  applies to an element  $\beta$  only if morphological properties of  $\beta$  itself are not otherwise satisfied in the derivation.

In other words,  $\alpha$  moves only to satisfy its own morphological needs, and in this sense the movement is a last resort; the movement should not therefore be done for the benefit of the target K. Let us consider how Greed works.

(19) \* Seems to [a strange lady] that it is raining outside<sup>5</sup>

---

<sup>4</sup> This example comes from Manzini's 1995-1996 Winter lecture, at UCL.

<sup>5</sup> The example in (19) comes from Manzini 1995-1996 Winter lecture, at UCL.

In (19) the matrix I has a DP-feature (Case) to check, but a strange lady whose case feature is checked by that of the preposition P cannot raise to [Spec,IP] to satisfy the Case feature of I because movement of a strange lady would satisfy the needs of I but not of the DP itself, violating Greed.

In contrast, from the viewpoint of a target K, which Chomsky (1995, Chapter 4) takes, Last Resort is expressed in terms of the feature-checking of a target K rather than Greed of an element  $\alpha$ : movement of an element  $\alpha$  takes place because of the feature-checking needs not of an element  $\alpha$  but of its target K. A target K attracts an element  $\alpha$  to check off the morphological features of K with the corresponding features of  $\alpha$ . For instance, the sentence (19) results in an ungrammatical derivation since the Case feature of the target I in (19) above remains unchecked.

### 1.2.3.3. Shortest Link, Fewest Steps, and Procrastinate



Intuitively, the basic Principle of Economy amounts to saying that human beings want to achieve a maximum of effects at a minimum of effort. Thus, movement is allowed only when the derivation would otherwise crash. Any derivation involving unnecessary or superfluous movements violates the Economy Principle. According to M.-G. Yoon (1996), the same general notion of derivational Economy also encompasses the following subprinciples:

#### (20) Economy

- a. Shortest Link: A derivation with a longer link is blocked.

- b. Fewest Steps: A derivation with more than the minimal steps is blocked.
- c. Procrastinate: Wait as long as possible. LF-movement is cheaper than overt movement.

The principle of Shortest Link (which equals Minimal Link Condition (MLC)) explains some examples which are accounted for in terms of Rizzi's (1990) Relativized Minimality or theories such as the Head Movement Constraint<sup>6</sup> (HMC), and the Superiority condition. The following example is one showing Head Movement.

- (21) a. [CP Should<sub>i</sub> [IP John [VP t<sub>i</sub> [VP have [VP done it ?]]]]]
- 
- b. \* [CP Have<sub>i</sub> [IP John [VP should [VP t<sub>i</sub> [VP done it ?]]]]]
- 

The movement of Should in (21a) involves a shorter link (should, t) than that of Have as in (21b) (Have,t).

The principle can also account for why the superiority violation example in (22b) is ungrammatical.

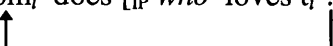
- (22) a. [CP Who<sub>i</sub> [IP t<sub>i</sub> loves *whom* ?]]
- 
- b. \* [CP Whom<sub>i</sub> does [IP *who* loves t<sub>i</sub> ? ]]
- 

---

<sup>6</sup> With respect to constraints on movement and locality, see also Manzini (1992, 1994a).

According to the Shortest Link Principle, the Link (who, t) in (22a) is shorter than the Link (whom, t) in (22b). The condition that a wh-phrase cannot cross another wh-phrase may be explained in terms of the Shortest Link Principle.

The Shortest Link Principle and the Fewest Steps Principle have the effect of explaining Superraising, since the movement of it to [Spec,IP3] in (23) is shorter than that of John (see the movement of John in (24) satisfies the Shortest Link Principle):

(23) \* [IP3 John<sub>i</sub> appears [IP2 it is likely [IP1 t<sub>i</sub> to leave ]]]

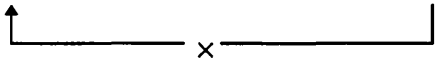

(24) [IP John<sub>i</sub> appears [IP t<sub>i</sub> to leave]]

However, suppose that John in (23) first moves to the current position through [Spec,IP2] before it is inserted. This movement does not violate the Shortest Link Principle. Nevertheless, the sentence in (23) is still ungrammatical. Based on Chomsky (1995), M.-G. Yoon (1996) explains the ungrammaticality of (23) in terms of the Fewest Steps Principle. If John moves to [Spec,IP3] through [Spec,IP2], satisfying the Shortest Link Principle, and it is inserted after the movement of John, this operation involves two steps: the movement of John is one step, and the insertion of it is another step. Therefore, the movement of John and the insertion of it into the position where John stops violates the Principle of Fewest Steps.

Notice at this point that the Principles of Shortest Link and the Principle of Fewest Steps contradict each other. Let us consider the example in (25).

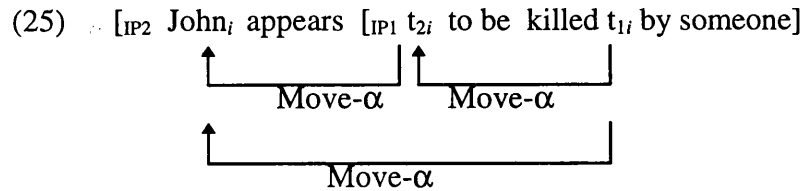

If we assume that John moves to [Spec,IP2] through [Spec,IP1] producing two links (John,t<sub>2</sub>) and (t<sub>2</sub>,t<sub>1</sub>), this operation satisfies the Shortest Link Principle but violates the Fewest Steps since it produces two steps (two movements). To avoid this contradiction, Chomsky (1995) says that one step may consist of more than one application of Move- $\alpha$ . In particular, Chomsky (1995) defines an operation of ‘Form-Chain’ according to which the movement of John from the object position to [Spec,IP2] through [Spec,IP1] produces a single step (John,t<sub>2</sub>,t<sub>1</sub>) rather than the two steps ((John,t<sub>2</sub>) and (t<sub>2</sub>,t<sub>1</sub>)). This is possible under the assumption that one step may consist of more than one application of Move- $\alpha$ . Thus the introduction of Form-Chain satisfies the Principle of Fewest Steps as well as the Principle of Shortest Links.

Now the examples which were accounted for under HMC, Superiority and Superraising can be explained in terms of Economy.

The Principle of Procrastinate is also crucial in explaining word order variation among languages. For instance, Chomsky (1995) accounts for the variation in terms of weak and strong features associated with its functional projections. That is, V-

features of I in English are weak, while in French they are strong<sup>7</sup>. The strong features must be checked and deleted, forcing movement of the Verb. If so, the French verb in (26b) moves in overt syntax, while the English verb in (26a) does not move overtly:

- (26) a. John        often [VP lost his mind ] ---- English  
           ↑  
       b. Jean *perdit<sub>i</sub>* souvent [VP t<sub>i</sub> la tête ] ----- French  
           ↑

The difference between English and French in word order however also requires the Procrastinate Principle. The movement of lost in English is constrained by the Procrastinate Principle which delays a syntactic operation as much as possible.

The difference between English and Korean with respect to wh-movement can also be explained in terms of Procrastinate. The wh-phrase in English-type languages overtly moves into [Spec,CP] while the wh-movement in Korean (or Japanese)-type languages is done covertly in LF, as in (27):

- (27) a. [CP Who<sub>i</sub> [ did [IP John meet t<sub>i</sub> ? ] ] ]  
           ↑  
       b. [CP        [IP John-i *nuwkwu*-lul manna-ss-ni ? ] ]  
           ↑  
           Nom           ]who-Acc meet-Pst-Q  
           ‘Who did John met ?’

In the view of Chomsky (1995), the Wh-feature of C in English is strong, requiring a wh-phrase to raise to CP, while that of C in Korean is weak, preventing the wh-phrase from raising to [Spec,CP] by Procrastinate.

---

<sup>7</sup> See also 1.2.10 for discussion of strong and weak features.

#### 1.2.4. Definition of Checking Configuration

Unlike in GB theory, the relation of “government” plays no role in the minimalist program. Under the government-binding theory for Case-assignment, a DP receives a Case feature from a head bearing this Case feature under government during the course of the derivation. Under the minimalist program, however, a DP already bearing a Case feature in the lexicon must be checked during the course of the derivation against a corresponding feature borne by another element within a prescribed local “checking” configuration.

Let us consider the definition of checking configuration by considering the structure in (28) which is reproduced from Chomsky (1995, p. 177).

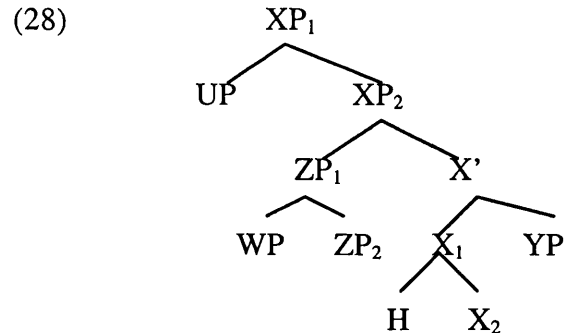

Chomsky (1995) says that XP, ZP, and X in (28) each consists of a higher and lower segment, indicated by numbers 1 and 2 subscripted. Furthermore, Chomsky (1995, pp.177-178) assumes notions such as ‘*dominate*,’ ‘*contain*,’ ‘*domain*,’ etc. in (29), and ‘*reflexively dominate*’ in (30).

(29) a. The category  $\alpha$  *dominates*  $\beta$  if every segment of  $\alpha$  dominates  $\beta$ .



- b. The category  $\alpha$  *contains*  $\beta$  if some segment of  $\alpha$  dominates  $\beta$ .
- c. The *domain* of a head  $\alpha$  is the set of nodes contained in the maximal projection of  $\alpha$  that are distinct from and do not contain  $\alpha$ ; thus the domain of X in (28) is {UP, ZP, WP, YP, and H}.
- d. The *complement domain* of  $\alpha$  is the subset of the domain reflexively dominated by the complement of  $\alpha$ ; the complement domain of X in (28) is {YP}.
- e. The *remainder (residue)* of  $\alpha$  is its domain minus the complement domain of  $\alpha$ ; the residue of X in (28) is {ZP, UP, WP, H}
- f. The *minimal S (set)* (S= domain, complement domain, residue ) is the smallest subset K of S such that for any  $\gamma \in S$ , some  $\beta \in K$  reflexively dominates  $\gamma$ .

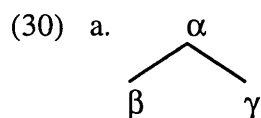

- b.  $\alpha$  dominates  $\beta, \gamma$ .
- c.  $\alpha$  *reflexively dominates*  $\alpha, \beta, \gamma$ .

According to the definition of domination expressed in (29a), in the structure (28), XP consisting of two-segment categories  $XP_1$  and  $XP_2$  dominates ZP, WP, X', and whatever they dominate. According to (29b), XP contains UP and whatever UP dominates, while ZP contains WP. But XP and ZP do not dominate UP and WP. The two-segment X consisting of  $X_1$  and  $X_2$  contains H but does not dominate it.

Concerning the notion of minimal domain, Chomsky (1995, p. 178) says:

“The minimal domain of X in (28) is { UP, ZP, WP, YP, H}. The minimal complement domain of X is YP and its minimal residue is {UP, ZP, WP, H}. The minimal domain of H is {UP, ZP, WP, YP}; its minimal complement domain is YP; and its minimal residue is {UP, ZP, WP}. The minimal complement domain of X is called its internal domain, and the minimal residue of X its *checking domain*.”

Before extending the notions considered so far to a nontrivial chain (CH) with  $n > 1$  ( $\alpha_1$  is a zero-level category) in  $CH = (\alpha_1, \dots, \alpha_n)$ , where we limit our attention to the case of  $n=2$ , let us first consider the notion of Larson’s (1988) VP-Shell.

In analysing the double object structure, Larson (1988) proposes a VP-shell structure, according to which a sentence like (31) will have a Structure like (32).

(31) Peter put the book on the desk

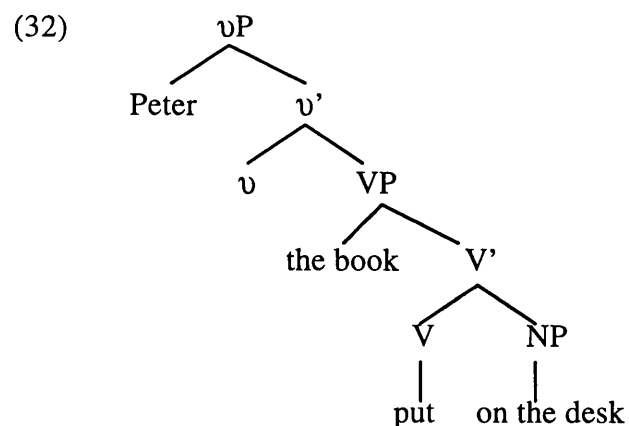

The verb put is assumed to move to the small v position by substitution or adjunction, forming the chain (put, t).

Chomsky (1995, pp. 179-180) prefers adjunction movement over substitution movement in relation to verb movement. Then the structure for (31) will be (33).

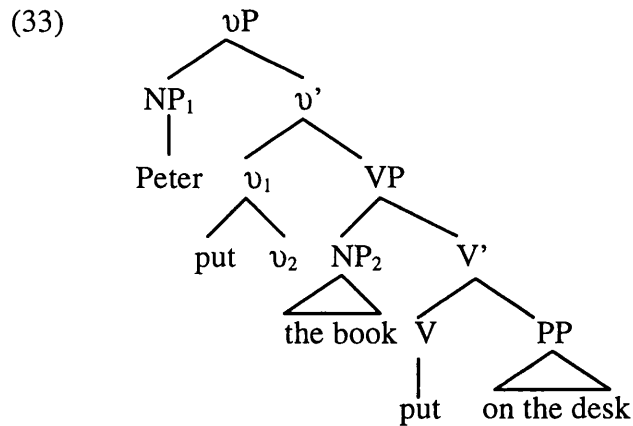

The verb put is supposed to adjoin to the empty small  $v$  position, forming the chain (put,  $t$ ). The notion of domain of the chain is then defined as follows (Chomsky 1995, p. 180):

- (34) a. The domain of the chain  $(\alpha_1, \dots, \alpha_n)$  is the set of nodes contained in the maximal projection of  $\alpha_1$  that are distinct from and do not contain  $\alpha_1$ .
- b. The complement domain of the chain  $(\alpha_1, \dots, \alpha_n)$  is the subset of the domain of the chain  $(\alpha_1, \dots, \alpha_n)$  reflexively dominated by the complement of  $\alpha_1$ .
- c. The remainder (residue) of the chain  $(\alpha_1, \dots, \alpha_n)$  is its domain of the chain  $(\alpha_1, \dots, \alpha_n)$  minus the complement domain of  $\alpha_1$ .

According to the definition of the domain of chain in (34) and the notion of the minimal domain, the minimal domain of the chain (put,  $t$ ) in (33) is  $\{NP_1, NP_2, PP\}$ ;

the internal domain of the chain (put, t) is {NP<sub>2</sub>, PP}; the checking domain of the chain is then {NP<sub>1</sub>}.

With this background, let us consider the movement of the object to [Spec,Agr<sub>o</sub>P] in the structure (35), which is motivated in covert syntax in English by reason of case checking:

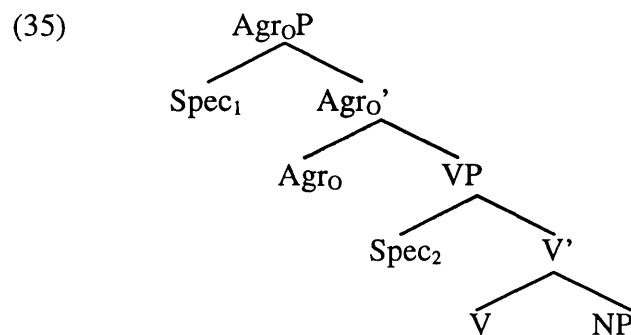

If the verb V moves to Agr<sub>o</sub> by adjunction, the chain (V, t) is formed. Then, according to the notion of the minimal domain of the chain, the minimal domain of the chain (V, t) in (35) is {Spec<sub>1</sub>, Spec<sub>2</sub>, NP}. The movement of the object to [Spec,Agr<sub>o</sub>P] in LF apparently violates the Shortest Link Principle or MLC<sup>8</sup> requiring the object NP to move to the closest position which is [Spec,VP] rather than [Spec,Agr<sub>o</sub>P]. To rescue movement of object to [Spec,Agr<sub>o</sub>P], Chomsky (1995) introduces the notion of equidistance (Chomsky 1995, p. 184-185).

(36) If  $\alpha$ ,  $\beta$  are in the same minimal domain, they are equidistant from  $\gamma$ .

---

<sup>8</sup> See also Section 1.2.7. for a detailed discussion of the Minimal Link Condition (MLC).

If the verb moves to Agr<sub>O</sub> in (35), the minimal domain of the chain (V,t) is {Spec1, Spec2, NP}, as seen above. If so, according to the notion of equidistance, Spec1 and Spec2 are equidistant from NP. This means that the object NP can move to [Spec,Agr<sub>O</sub>P] (Spec1), crossing [Spec,VP] (spec2), without violating the Minimal Link Condition (MLC).

### 1.2.5. Numeration and Select

After reviewing the concepts of level of representation and Economy, we can now consider in some detail the actual operation of the grammar: Select, Merge, and Move. Concerning the choice of a lexical item from the lexicon, Chomsky (1995, p. 225-226) suggests a two-step operation: the first step forms a *Numeration* which consists of a set of lexical pairs (LI, *i*), where LI is a lexical item chosen from the lexicon and *i* is its index (the number of times that LI is selected). The second step is the operation of *Select* which picks up a lexical item LI from the Numeration, reducing its index by 1 whenever it is picked up and inserting it into the syntactic derivation.

With respect to the insertion of lexical items into phrase structures, one of the significant changes in the minimalist program compared to GB theory is that lexical items are inserted from the lexicon in a fully inflected form. In GB theory the verb is inserted into VP in a bare (uninflected) form and then the inflectional features such as Tense and Agreement lower to the bare Verb within VP in the case of English (or the bare Verb raises to some functional head to receive the inflectional features in the case of French). However, in the minimalist program, the verb is inserted into its base position within VP with the already fully inflected form; in the case of English

the fully inflected verb remains in situ in overt syntax and moves up to the head of AgrP to check its inflectional features in LF, while in the case of French the verb moves overtly. This leads the grammar to dispense with the unwelcome assumption that some inflections such as T and Agr may lower to the verb position in the VP in languages like English.

#### 1.2.6. Merge

In GB theory, phrase structures are fully constructed as a completely built-up structure (D-Structure) before movement operations start. Chomsky (1981) calls the completely built-up structure D-Structure. In contrast, in the minimalist program, Chomsky (1995) suggests that phrase structures are built up piece by piece as the computation, including crucially movement, proceeds. This suggestion enables the grammar to eliminate D-Structure. In other words, an operation of phrase structure build-up (including the operation of choosing lexical items from the numeration and inserting them into phrase structures) is incorporated into the derivational process. In the minimalist program, the operation of building up phrase structures is called *Merge*.

Given a pair of syntactic objects ( $\alpha$ ,  $\beta$ ) which are selected from the Numeration, the operation 'Merge' constructs a new syntactic object out of the pair ( $\alpha$ ,  $\beta$ ) creating a single syntactic object (K). Alternatively, it combines a new lexical item and a syntactic structure already formed, and 'Merge' can also combine two phrases. With respect to the identity of K, Chomsky (Chomsky 1995, p. 244-246) says:

“K is either one or the other of  $\alpha$ ,  $\beta$ ; I exclude the possibilities of the intersection of  $\alpha$  and  $\beta$ , or the union of  $\alpha$  and  $\beta$ ; if  $\alpha$  projects, K will be  $\{\alpha, \{\alpha, \beta\}\}$ , and if  $\beta$  projects, K will be  $\{\beta, \{\alpha, \beta\}\}$ . The operation Merge ( $\alpha$ ,  $\beta$ ) then is asymmetric, projecting either  $\alpha$  or  $\beta$ . The element which projects becomes the label of the complex newly formed. In general, the syntactic object K must be of the form  $\{\gamma, \{\alpha, \beta\}\}$ , where  $\gamma$  identifies the type to which K belongs.  $\gamma$  is called the label of K.”

### 1.2.7. Move

In the earlier versions of the minimalist program, the operation ‘Move- $\alpha$ ’ is motivated by the morphological features of  $\alpha$  i.e. by Greed. Nouns and Verbs are assigned morphological features when they are chosen from the lexicon. They are inserted into phrase structures with the fully inflected form. Movements then take place to check their morphological features off: an element  $\alpha$  moves to a target K to check its morphological features by the corresponding features of the target K. For example, a DP already bearing a Nominative Case feature moves to [Spec,Agr<sub>s</sub>P] to have its Nominative case feature checked against a corresponding feature borne by another element (or T adjoined to Agr<sub>s</sub>). Notice that this is fundamentally different from in GB theory, where one can move anything to anywhere; the unwanted movement is constrained by principles and conditions, such as theta theory, case theory, binding theory, etc.

In Chapter 4 of the Minimalist Program (Chomsky 1995), on the other hand, Chomsky changes the viewpoint of movement: movement takes place because of the feature checking needs not of an element  $\alpha$  that moves but of its target K. An element  $\alpha$  does not move to a target K to check off the morphological features of

the element  $\alpha$  itself. On the contrary, a target K attracts an element  $\alpha$  to check off the morphological features of K by the corresponding features of  $\alpha$ . Chomsky calls this movement Attract- $\alpha$ .

### 1.2.7.1. Movement and Uniformity Condition

The question now arises of the derived structure created by movement. In Move- $\alpha$  operations, the moved  $\alpha$  cannot project. If  $\alpha$  in the base position is XP and projects in the moved position, this operation violates the uniformity condition according to which the moved  $\alpha$  and its trace  $t_\alpha$  in the chain  $(\alpha, t_\alpha)$  must have the same phrase structure status. Indeed if  $\alpha$  projects, this means that  $\alpha$  is  $X^0$ . XP cannot project. Another possibility is the head movement of  $\alpha$ . That is, the moved  $\alpha$  is  $X^0$  and its trace is also  $X^0$ . This assumption implies that the target K should be a complement of the moved  $\alpha$ :  $\{ \alpha, \{ \alpha, K \} \}$ . However, this movement of  $\alpha$  cannot check its features against the features of K which is a complement of  $\alpha$  since there is no feature checking operation between a head and its complement. Chomsky (1995, p.257) remarks: “No property P can be checked in the head-complement structure that has been formed”. In other words, the substitution movement and projection of the moved  $\alpha$  is barred. Chomsky (1995, p.260) concludes that only the target K projects, whether the movement is substitution or adjunction, overt or covert.

### 1.2.7.2. Attract-F

The basic motivating force behind movement considered so far is morphologically feature-driven. With this background, Chomsky (1995, Chapter 4) further extends his minimalist idea, proposing that movement is essentially Attract-



F(eature). In other words, K attracts just the feature F of a lexical item  $\alpha$ , not the whole lexical item  $\alpha$  itself. Only the formal features of  $\alpha$  raise to target K to check the features of the target K, and the remaining features of  $\alpha$  are left behind, consistent with a natural economy condition.

Now let us consider how ‘Attract-F’ operates in a few examples. A feature X can enter the checking domain of X by ‘Merge’ or by ‘Move’. To take the example of Chomsky (1995), the feature Q(uestion) can be checked by ‘Merge’ of whether in [Spec,CP], as illustrated in (37) below.

(37) I wonder [<sub>CP</sub> whether [<sub>C<sup>0</sup></sub> [Q] [<sub>IP</sub> he bought the car.]]]

Or Q can be checked in [Spec,CP] by ‘Move’ (that is, by wh-movement) of which car, as shown in (38).

(38) I don’t know [<sub>CP</sub> [which car]<sub>i</sub> [<sub>C<sup>0</sup></sub> [Q] [<sub>IP</sub> he bought t<sub>i</sub>.]]]

Alternatively, a lexical item bearing a Q feature can be inserted by adjunction to C<sup>0</sup> by ‘Merge,’ as illustrated in (39) below in the if:

(39) I wonder [<sub>CP</sub> [<sub>C<sup>0</sup></sub> if [Q] [<sub>IP</sub> he bought the car.]]]

Similarly ‘Move’ to C<sup>0</sup> of did can satisfy Q as in (40).

(40) [<sub>C<sup>0</sup></sub> Did] you buy a car ?

In all four cases what is crucial is the satisfaction of the Q feature by matching features.

We can also consider the following Korean case in which a ‘topic’ phrase is inserted by ‘Merge’. The feature *Topic* is checked by ‘Merge’ of kkot into [Spec,TopP]:

- (41) [TopP kkot-un [Top Top] [ tulip-i          ceyili-ta.]]  
          flower-Top                    tulip-Nom          best-Dec  
          ‘As for flowers, tulips are the best.’

In this case, for reasons that will be discussed in Chapter 4, movement is not involved. KKot is inserted directly from the lexicon by ‘Merge’.

By contrast, John which is topicalized in (42) seems to be moved to [Spec,TopP] from the object position, as in (42a), or the subject position, as in (42b).

- (42) a. [TopP [John<sub>i</sub>-un] [Top Top] [ i salam-i t<sub>i</sub>/\*ku<sub>i</sub>-lul boa-ss-ta.]]  
                                         Topic                    this man-Nom/he-Acc          see-Past-Dec  
                                         ‘John<sub>i</sub>, this man saw.’ or ‘As for John<sub>i</sub>, this man saw him<sub>i</sub>.’  
    b. [TopP [John<sub>i</sub>-un] [Top Top] [ t<sub>i</sub>/??ku<sub>i</sub>-ka i salam-ul boa-ss-ta.]]  
                                         Top     he-Nom this man-Acc          see-Past-Dec  
                                         ‘As for John<sub>i</sub>, he<sub>i</sub> saw this man.’

The operation Attract- $\alpha$  is now understood as Attract-F(feature). However, in overt syntax, a whole category rather than features raises. Chomsky (1995) finds an answer to this puzzle in the properties of the phonological component which require

pied-piping of a whole lexical item. For example, in whose book, the ‘wh-feature’ alone cannot be attracted to a target K but it must be attracted to the target K together with its residue ‘-’s book’. If only the wh-feature moves to check its strong Q feature, the derivation will crash at PF for phonological reasons, namely, the unpronounciability of the feature in isolation. But in Japanese wh-questions such wh-feature movement should be permitted, as argued by Watanabe (1992). This analysis of Japanese therefore supports the Attract-F theory. The pied-piping of a whole lexical item is forced only because of PF convergence.

### **1.2.7.3. Interpretability of Features**

In the Attract-F theory, the interpretability of features becomes paramount. In an earlier version of the minimalist program, the checked features are regarded as being deleted. However, Chomsky (Chomsky 1995, Chapter 4) later corrects the argument and argues that some features remain visible at LF even after being checked. The more important point to note is not whether the features are checked but whether they are interpretable. If the features are [+] interpretable, they can survive to LF. By contrast, if they are [-] interpretable, they should be checked and deleted independently of whether they are strong or weak before the derivation reaches LF.

### **1.2.7.4. MLC and Attract- $\alpha$**

Another notion to consider in its interaction with Attract- $\alpha$  is that of Minimal Link Condition. The Minimal Link Condition (MLC) can be expressed within the ‘Attract’ framework as follows (Chomsky 1995, p. 311):

(43) Minimal Link Condition

K attracts  $\alpha$  only if there is no  $\beta$  closer to K than  $\alpha$ , such that K attracts  $\beta$ .

The notion of closeness for 'Attract' is defined in (44) (Chomsky 1995, p. 356), if  $\beta$  c-commands  $\alpha$  and K is the target of raising, as in the structure (45).

(44)  $\beta$  is closer to K than  $\alpha$  unless  $\beta$  is in the same minimal domain as (a) K  
or (b)  $\alpha$ .

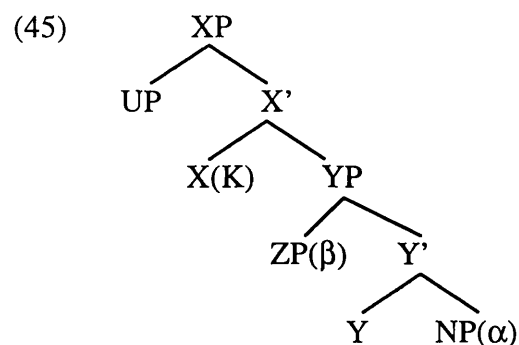

Let us consider how the MLC works in Superraising, taking the example in (46).

(46) \*  $\text{John}_i$  seems that it is likely  $t_i$  to win

John (or the D-feature of John) is attracted (or moved) to the matrix  $I^0$ , crossing it, a closer potential D-feature, violating the MLC which requires the closest features to be attracted.

The Head Movement Constraint (HMC) can also be accounted for in terms of the MLC in (43).

(47) \* Have<sub>i</sub> you will t<sub>i</sub> finished ?

Have (a head) cannot be attracted (be moved) to the target K C<sup>0</sup>, crossing the closer candidate will. The movement of Have in (47) therefore violates the MLC.

The MLC can also account for superiority. Let us consider the following sentence:

(48) a Whom<sub>i1</sub> [C<sup>0</sup> did] John persuade t<sub>i</sub> to visit whom<sub>2</sub>  
 b. \* Whom<sub>i2</sub> [C<sup>0</sup> did] John persuade whom<sub>1</sub> to visit t<sub>i</sub>

The matrix C<sup>0</sup> in (48a) having [+wh] must attract the closer whom<sub>1</sub> rather than the longer whom<sub>2</sub>. However, in (48b) the more distant whom<sub>2</sub> is attracted to the matrix C<sup>0</sup>, crossing whom<sub>1</sub> and resulting in a violation of the MLC.

### 1.2.8. Bare Phrase Structure

The basic phrase structure format for English assumed in GB theory is as illustrated in (49).

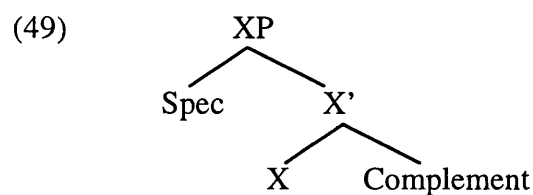

However, in the minimalist framework, Chomsky (1995, pp. 241-249) abandons standard X-bar theory as in (49) where only one Spec position is allowed, and instead assumes that a lexical item does not project in the X-bar format ( $X^0$ ,  $X'$  XP). The new assumptions concerning phrase structure enable us first of all to dispense with structures such as (50a) and instead to have the ‘Bare Phrase Structure’ (BPS) without X-bar format<sup>9</sup> as in (50b).

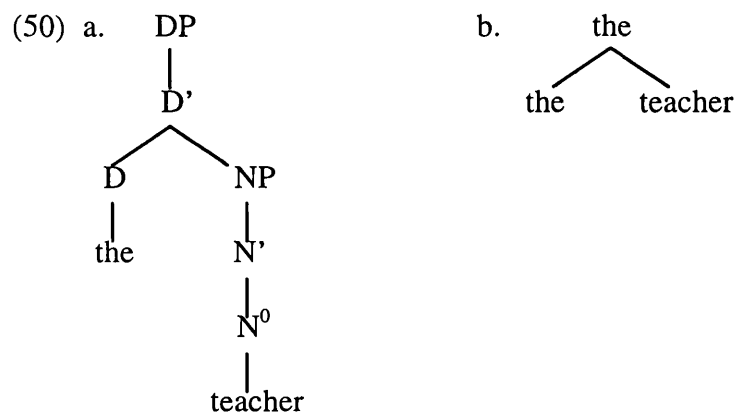

To give another example (51a) is the structure assumed in the Bare Phrase Structure Theory while (51b) is the structure in the standard X-bar theory.

---

<sup>9</sup> However, Chomsky (1995) uses the X-bar notation for convenience. I also use the X-bar notation in this thesis for the same reason.

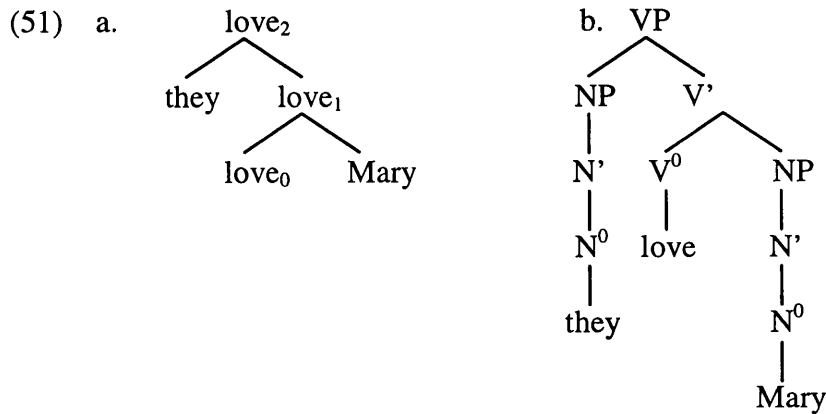

In BPS, there are no bar levels. An effect of the Bare Phrase Structure theory is that a lexical item can be both a head ( $X^0$ ) and a maximal projection (XP). As an example, Chomsky (1995, p. 249) takes clitics; they appear to share XP and  $X^0$  properties. According to his explanation, a clitic moves from its theta-position (which means that the clitic is (XP)) and attaches to an inflectional head ( $X^0$ ) (which implies that the attached clitic should be a head). This requires that the clitic must be both XP and  $X^0$ . This phenomenon is well accommodated in the minimalist program dispensing with the notion of XP,  $X'$  or  $X^0$ .

The Bare Phrase Structure theory assumes that a head can select just one complement like in the X-bar theory (Chomsky 1986a) but a head can select more than one Spec, as illustrated in (52).

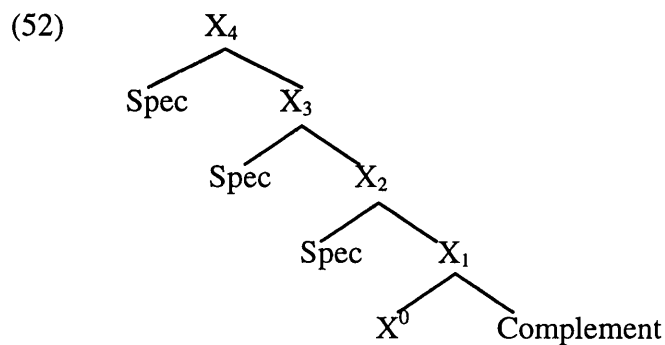

Given multiple Spec positions, we may have multiple subjects, and this is indeed the case according to Ura (1994) for instance in Moroccan Arabic, as illustrated in (53b).

- (53) a. Zayd-un    ?abuh-u    marid-un (Moroccan Arabic, Ura 1994)  
 Zayd-Nom    father-Nom    ill-Nom  
 ‘Lit. Zayd, (his) father is ill.’ (It is Zayd that his father is ill.)

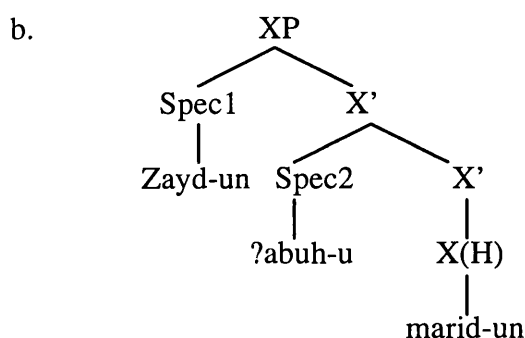

Nominative Case for Zayd and ?abuh can be checked by the verb marid. Crucially the Nominative Case feature of the verb may check the Case feature of its Specs as many times as wanted. In this analysis therefore the first and the second Nominative nominals are both structurally case-marked (or checked). In other words, the assumption of multiple Specs seems to enable us to account for multiple subject constructions in languages like Moroccan Arabic. In Chapter 5 of this thesis, however, I will argue that Double Subject Constructions (Double Nominative Construction) in Korean cannot be accounted for in terms of multiple Specs. I will claim that the first Nominative NP is structurally Case-marked (checked) in a functional phrase, but the second Nominative one is inherently case-marked in situ within VP since the second nominal in DNCs shows indefiniteness (or non-



specificity) effects. If the first Nominative NP and the second Nominative NP are both structurally case-marked in Spec positions, the structure would be as shown in (54).

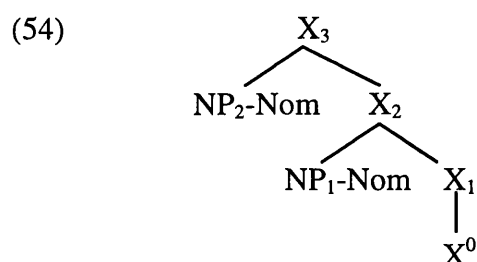

According to Mahajan (1990), structurally Case-marked NPs show definiteness properties while non-structurally Case-marked NPs (inherently marked by their head) are indefinite or non-specific. Thus the first NP in DNCs in Korean seems to be structurally case-marked showing definiteness properties, but the second NP shows an indefiniteness (non-specificity) effect. I will return to this matter in Chapter 5.

In short, it is my claim that the first NP in Korean DNCs is raised from inside VP to [Spec,Agr<sub>S</sub>P] where it is structurally Case-marked while the second NP is inherently Case-marked in VP without movement.

In relation to the assumption of multiple specs, it is worth considering furthermore Transitive-Expletive Constructions (TEC) in Icelandic and *there-expletive* constructions in English. Chomsky (1995, p. 341), following Jonas and Bobaljik (1993), suggests that [Spec,TP] is a position where a nominal phrase can appear. According to Jonas and Bobaljik (1993), the expletive in a TEC appears in [Spec,Agr<sub>S</sub>P], the subject a student moves to [Spec,TP] from [Spec,VP], and the

object the house within VP moves to [Spec,Agr<sub>OP</sub>]; the verb painted is raised to the head of Agr<sub>S</sub>P through the heads of TP and Agr<sub>OP</sub>, as illustrated in (55) (example from Chomsky (1995, p.341) with English words substituted for Icelandic ones):

(55) [<sub>Agr<sub>SP</sub></sub> there painted<sub>j</sub> [<sub>TP</sub> a student<sub>i</sub> [<sub>Agr<sub>OP</sub></sub> the house<sub>k</sub> [<sub>VP</sub> t<sub>i</sub> t<sub>j</sub> t<sub>k</sub>]]]]]

According to Chomsky (1995) the TEC is also a kind of Multiple Subject Construction (MSC) with there and a student in different Specs of the same head I.

#### 1.2.8.1. Elimination of Agr

Following the assumption that the subject can appear in [Spec,TP], Chomsky (1995, pp. 349-355) eliminates Agr from the lexicon. This implies that the functional categories which may be drawn from the lexicon for the Numeration are only C, T and D. The functional categories C, T, and D have some features interpretable at LF such as the wh-feature(Q-feature), the Tense-feature, the Definiteness feature, etc. But Agr does not have such features interpretable at LF. The features of AGR are all [-interpretable] at LF. In this sense, AGR seems to exist for purely theory-internal reasons. Thus Chomsky (1995) claims that AGR can be eliminated from the lexicon. Then N-features such as Number and Person are added to the verb when the verb is chosen from the lexicon for the Numeration. He further suggests that the N-features are checked in TP between the subject and the verb. The subject appears in [Spec,TP] and the verb adjoins to T<sup>0</sup> overtly in French and in LF in English. Furthermore, while the subject overtly moves to [Spec,TP], the object covertly

moves to some other Spec position of  $\nu P$ , as in (56). Without Agr, the clause structure for an English sentence would then be the following:

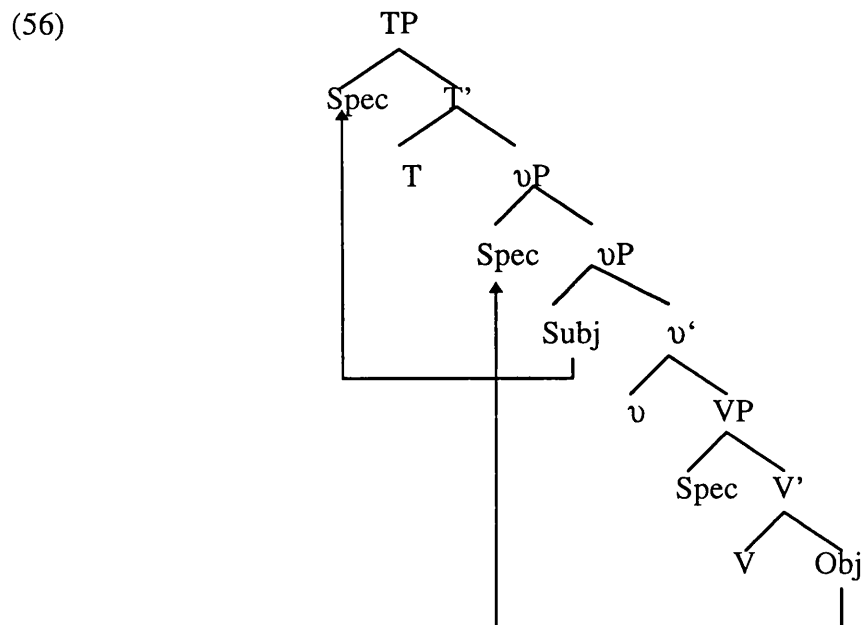

How is the expletive-associate construction in English accounted for without Agr? Given the elimination of  $Agr_S$  and  $Agr_O$ , the clause structure will be like (56). In this analysis, [Spec,TP] is used as the position for the expletive there.

- (57) a. There is a book on the table.  
 b. There are books on the table.

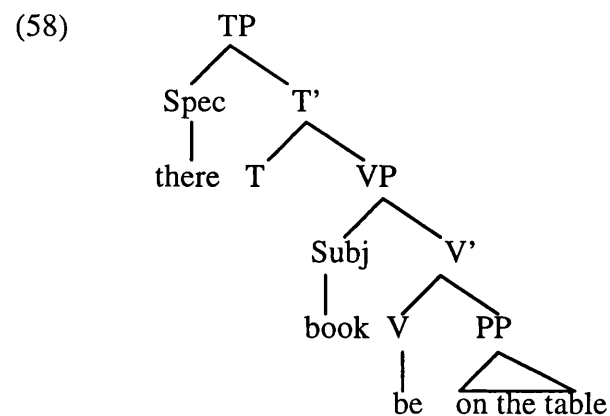

According to Chomsky (1995), the feature agreement between the associate book and the verb be takes place like this: the formal features FF(book) move to T to check the formal feature (FF) of the verb which adjoins to T. This mechanism needs not only multiple specifiers but also PF-reordering to accommodate TEC's.

More to the point: how can TECs be accommodated without Agr ? Naturally, in Icelandic, the Expletive and Subject appear in [Spec,TP], and the verb moves to T<sup>0</sup>. This analysis is possible on the assumption that [Spec,TP] can be projected as many times as wanted.

With respect to the existence of Agr in Korean, some Korean linguists (H.-D. Ahn 1988, J.-Y. Yoon 1990, and D.-W. Yang 1995 among others ) argue that Nominative Case in Korean is marked by AGR and not by Tense. According to J.-Y. Yoon (1990), Nominative Case is assigned to the subject of non-finite, as well as finite clauses, which implies that Nominative Case is not licensed by [+Tense] in Korean. The following examples are reproduced from J.-Y. Yoon (1990).

- (59) a. [Nay-ka ku il-ul ha-ki]-ka elyep-ta.  
 I-Nom the work-Acc do-Comp-Nom difficult-Dec  
 'It is difficult for me to do the work.'
- a'. \* [Nay-ka ku il-ul ha-yess-ki]-ka elyep-ta.  
 I-Nom the work-Acc do-Pst-Com-Nom difficult-Dec
- b. Mary-ka [apeci-kkese ka-si-tolok] hay-ss-ta.  
 Nom father-Nom+Hon go-Hon-cause do-Pst-Dec  
 'Mary caused her father to go.'
- b'. \* Mary-ka [apeci-kkese ka-si-ess-tolok] hay-ss-ta.  
 Nom father-Nom+Hon go-Hon-Pst-cause do-Pst-Dec

J.-Y. Yoon (1990) presents another example, (60), which shows that a number agreement (plural) morpheme is inserted in a non-finite clause.

(60) [Haksayng-tul-i ppali talye-tul-o-ki]-ka elyep-ta.  
student-Pl-Nom quickly run-Pl-come-Comp-Nom difficult-Dec  
'It is difficult for the students to come quickly.'

From these observations, J.-Y. Yoon (1990) concludes that [+Tense] is not responsible for Nominative Case-marking but AGR is.

Based on this argument, I assume that there is AGR in clauses in Korean. In Chapter 2, I further assume that there is also AGR in noun phrases in Korean.

### 1.2.9. Feature-Checking and Case-Marking

As we have seen, the minimalist program replaces the notion of free movement with that of feature-driven movement. For example, if Case features must be checked in a derivation, a DP will move to check them. Failure to check a Case feature can lead to an uninterpretable structure at PF or at LF, which is ruled out by Full Interpretation.

Case theory in the minimalist program therefore reduces to feature-checking theory. Case-marking is assumed to be an instance of feature-checking between a functional category and its Spec. In the framework assumed here, just as Verbs are inserted in the VP along with fully inflected morphological features (e.g. Tense and Agreement) from the lexicon, DPs also are inserted with their features, including Case features. The Verbs or DPs then move to the relevant functional positions to

check their features. Movement of course can take place either in overt syntax (before Spell-Out) or in LF (after Spell-Out).

In GB theory, Nominative Case is assigned to the subject moved into the Spec of AGR<sub>S</sub>P from the position of [Spec,VP] while Accusative Case is assigned by Verbs to the object remaining in situ. In the minimalist program, on the other hand, both Nominative and Accusative case are marked (checked) in a uniform manner; the subject and object can both have one general structural configuration of assignment/checking.

#### **1.2.10. Feature-Driven Movement and Word Order**

In the Principles and Parameters framework (Chomsky and Lasnik 1993), word order variation is determined by the head-parameter: some languages are head-initial while others are head-final. But if syntactic operations are feature-driven, language variation must also depend on feature parametrization. Japanese is SOV because both the subject and the object check agreement overtly, which means that the subject and object move out of the VP in overt syntax while the verb remains in situ prior to Spell-Out. On the other hand, English has SVO because it has overt subject/verb agreement but not object/verb agreement; therefore only the subject moves overtly while the object moves covertly. If the verb was forced to move out of the VP while the subject and object remain within the VP prior to Spell-Out, these operations would yield a VSO order, as in Irish. The difference in surface word order among languages is reduced to the difference in movement induced by the ‘strong’/‘weak’ properties of features. “Weak” features need not be checked before Spell-Out since these features are invisible at the level of PF, while “strong”

features must be eliminated prior to PF, enforcing the application of overt syntactic movement, since “strong” features are visible in PF (and of course at PF they would violate FI). In discussing the Procrastinate Principle above, I have already illustrated the difference between strong features and weak features. Pollock (1989) argues that in French, unlike in English, the finite verbs raise into a functional head position overtly in syntax. Chomsky (1995) accounts for the contrast of word order between English and French with the notion of “weak” and “strong” features. The English verb in (26a) above surfaces within VP while the French verb in (26b) moves from inside VP to T.

#### **1.2.10.1. Word Order and Kayne’s LCA**

In this thesis, I assume the VP-internal Subject Hypothesis<sup>10</sup>, as is already implied from the preceding discussion, and Kayne’s (1994) universal Subject-Head-Complement word order hypothesis.

Kayne (1994) proposes a radical view about word order: linear order reflects hierarchical order through the Linear Correspondence Axiom (LCA). According to the LCA, if  $\alpha$  asymmetrically c-commands  $\beta$ ,  $\alpha$  must then linearly precede  $\beta$ . Any phrase marker which violates the LCA is barred. The notion of asymmetric c-command is expressed in (61).

(61) X asymmetrically c-commands Y iff X c-commands Y and Y does not c-commands X. (Kayne 1994, p.4)

---

<sup>10</sup> In the VP-internal Subject Hypothesis, the subject is inserted into [Spec,VP] from the lexicon, being assigned a theta role by the verb, and then is raised to [Spec,IP] to check Nominative Case feature in overt syntax (Fukui and Speas 1986, and Larson 1988).

Let us see how the LCA works by taking the simple phrase marker in (62). Italicised small letters indicate terminal elements, and capital letters non-terminal elements.

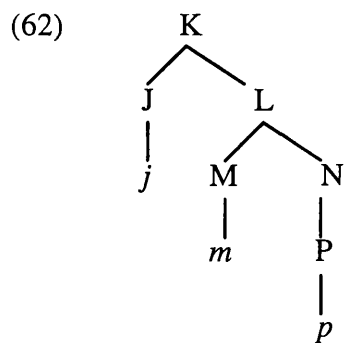

According to the LCA, the terminal *j* asymmetrically c-commands (and therefore precedes) *m* and *p*, as *m* does *p*. *j*, *m*, and *p* are all terminals in a phrase marker in (62) and the relationships between all the terminals are expressed in terms of asymmetric c-command. Thus, the phrase marker in (62) obeys the LCA. Now let us turn to another phrase marker in (63).

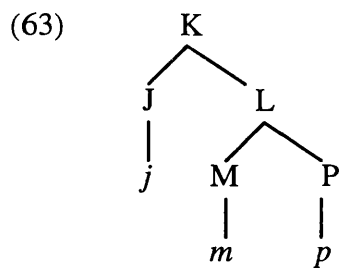

In the phrase marker in (63), *j* asymmetrically c-commands (and therefore precedes) *m* and *p*, but *m* does not asymmetrically c-command *p* and vice versa. The relationships between *j* and *m* and between *j* and *p* are expressed in terms of



asymmetric c-command. But there is no asymmetric c-command relationship between  $m$  and  $p$ . The phrase marker in (63) violates the LCA since there is a set  $(m, p)$  which does not express asymmetric c-command relationship. For the phrase marker in (63) to be acceptable to the LCA, the non-terminal P is not a minimal phrase ( $X^0$ ) but a maximal phrase (XP) like N in (62) and allows  $m$  to asymmetrically c-command (and therefore linearly precede)  $p$ . From this LCA, in (62)  $m$  must be a head and  $p$  a complement, and a universal word order (Spec-Head-complement) follows. In contrast, if  $p$  is a head and  $m$  is a complement, the phrase marker will be as in (64).

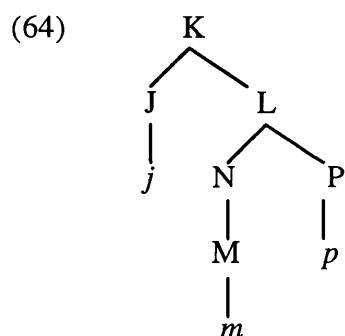

However, this phrase marker violates the LCA since  $p$  asymmetrically c-commands  $m$  but does not linearly precede  $m$ . One more to note is that the Kayne's (1994) LCA does not allow multiple specifiers but Chomsky (1995) does.

### 1.2.11. Summary

So far, we have reviewed the basic notions assumed in the minimalist program (Chomsky 1995). In particular, notions such as 'Merge' and 'Move,' 'Feature-driven Movement,' 'Case-Marking,' etc. have been examined.

Some of the major changes in the minimalist program compared to GB theory are:

- (i) an element does not move freely but only for some morphological reason. This feature-driven movement enables us to explain the movement of non-restrictive adnominal modifiers into Spec,DP, as will be seen in Chapters 2 and 3.
- (ii) Given the elimination of D-Structure, lexical insertion into a phrase marker takes place at any time during the derivation. This elimination of D-Structure can account for Topicalization in Korean in terms of ‘Merge’ and ‘Move,’ which we will consider in Chapter 4. Remember that, in GB theory, the lexical insertion is an ‘all-at-once’ operation which means that all lexical items must be inserted before the computation starts.
- (iii) In the minimalist program, Case-marking is done in terms of feature-checking in LF; in GB theory it is done in terms of Spec-head agreement for subject and government for object in S-Structure. In the minimalist program, multiple subject marking is accounted for in terms of multiple Spec. I will not make use of the multiple spec assumption for Double Nominative Case marking in Korean but I will account for double accusative case marking by using the multiple Spec assumption.

As we will see in the rest of the thesis, the assumptions newly adopted in the minimalist program can account for some phenomena which could not be resolved in previous frameworks. In this respect, the minimalist program (Chomsky 1995)

paves the way to a better understanding of grammar, though there still remains many challenging problems.

## CHAPTER 2

### AGREEMENT PHRASE IN DP

This Chapter consists of five sections. Section 2.1 offers brief discussions of the DP-hypothesis developed by Abney (1987) and of the clause structure of Korean.

Section 2.2 shows that there is an honorific and plural agreement between adnominal modifiers and their head nouns in the DP structure with the assumption that Korean noun phrases are selected by Determiner  $D^0$ .

In Section 2.3, I propose that pre-nominal attributive adjectives and relative clauses in Korean have the same structure as well as the same function, and that they are both base-generated in [Spec,AgrP] and check their agreement feature against the feature borne by  $N^0$  adjoined to the head ( $Agr^0$ ) of AgrP.

Section 2.4 is concerned with the movement of the external genitive argument in NP constructions. I contend that the external genitive argument NP in [Spec,NP] must move to [Spec,DP] for genitive case feature checking, just as the subject in [Spec,VP] moves up to [Spec,INFL] (or [Spec,AgrsP]) for nominative case checking.

In section 2.5, I discuss the movement of the head noun in Numeral-Classifier constructions within the DP-hypothesis.

#### **2.1. The DP-Hypothesis and the Fundamental Structure of the Clause**

According to recent research, Noun Phrases may be split into two major groups: one group, following Cinque (1980), has adopted the idea that NPs and VPs have a

parallel phrase structure; the other group argues that NPs are radically different from VPs (Grimshaw 1986). The first position is adopted in this thesis.

### 2.1.1. Parallel Structure of DP and IP

With respect to the structure of NPs, we adopt the framework of the DP-analysis (Abney 1987), according to which the noun phrase is headed by a functional category, namely, D (Determiner). On the other hand, Stroik (1994) proposes that noun phrases are headed by Q, not by D, and that the structure for deux livres ‘two books’ and des livres ‘books’ is as in (1a) and (1b) respectively, where an overt Q selects a DP with a zero D head while a zero Q selects a DP with an overt D head.

(1) a. Deux livres: [<sub>QP</sub> [<sub>Q</sub><sup>0</sup> deux ] [<sub>DP</sub> [<sub>D</sub><sup>0</sup> ∅] [<sub>NP</sub> livres]]]

b. Des livres: [<sub>QP</sub> [<sub>Q</sub><sup>0</sup> ∅ ] [<sub>DP</sub> [<sub>D</sub><sup>0</sup> des] [<sub>NP</sub> livres]]]

I would argue that the reverse order is true: [D [Q [N]]] with D probably unrealised (cf. (the) three books).

The main point of Abney (1987) is to argue for a parallel structure for noun phrases and clauses. Thus the noun phrase can be headed by a functional category D<sup>0</sup> just as the sentence is headed by a functional head I<sup>0</sup>, as follows:

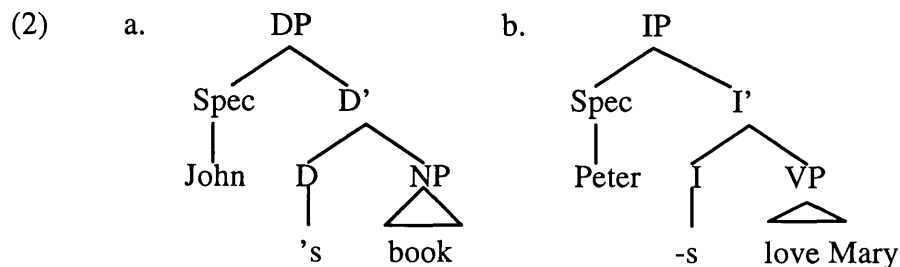

In this analysis, D(eterminer) is similar to the Infl in IP: the nominal John in [Spec,DP] checks the Case of the 's morpheme in D just like the subject Peter checks the Nominative Case of Infl -s through specifier-head agreement.

The parallel syntactic treatment of Det and Infl is reflected by their semantic similarity. The function of the determiner is to specify the reference set of a noun phrase. Abney (1987) says:

“The noun provides a predicate, and the determiner picks a particular set of numbers of that predicate’s extension. The same function is performed in the verbal system by Tense. The VP provides a predicate, that is, a class of events, and Tense (Infl) locates a particular event in time.”

### 2.1.2. Clause Structure in Korean

Whitman (1989) notes that English modals (shall, will, may, can, must) are generated in I<sup>0</sup> in a Pollock-type analysis:

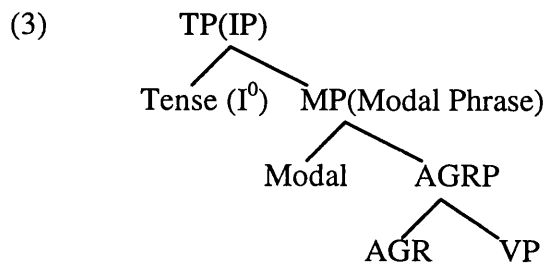

In an analysis like (3), MP must occur under the projection of Tense and the surface position of modals presumably results from raising of the Modal into I<sup>0</sup>. This is because English Modals are tensed (e.g. should, would, might, could), like verbs. Whitman (1989) says that English auxiliaries like ‘have/be’ trigger Subject/Aux

inversion and do not have 'do'-support, and that, in general, no English auxiliary appears above Tense.

However, based on the following examples in (4), Whitman (1989) argues that Korean Modals are not tensed and appear outside the position of tense morphology. According to Whitman (1989), *-kwun*, *-ci*, *-ta*, etc. in Korean are all modals which express apparentness, sus(picion) and declaration of a sentence.

- (4) a. ku-ka      ka-ss-*kwun*.  
he-Nom go-Pst-*App*  
'He has gone.'
- b. [Pro] pelsse   ttena-ss-keyss-*ci*.  
pro already leave-Pst-Fut-*Sus*  
'Pro has probably already left.'
- c. [pro] pelsse   ttena-ss-*ta*.  
pro already leave-Pst-*Dec*  
'Pro has already left.'

This observation indicates that the Korean Modal /Mood is the highest category in IP. Naturally, in the case of yes-no and wh-questions, CP can be posited above IP, just as in English. Whitman (1989) assumes that in Korean functional categories such as Tense, Modal and Complementizer are attached<sup>1</sup> to the verb from the lexicon, becoming a verbal complex consisting of the verb, tense, modal and complementizer, as seen in (5). Sentences in (5) are reproduced from Whitman (1989).

---

<sup>1</sup> This idea which I follow in this thesis is consistent with Chomsky (1995), where the verb is inserted from the lexicon with the fully inflected form.

- (5) a. [pro] pelsse *ttena-ss-ni(nya)* ?  
 pro already leave-Pst-Q  
 'Has (he) already left ?'
- b. Peter-un [<sub>CP</sub> Jane-i *ttena-ss-ta-ko*] saynggakh-an-ta.  
 Top Nom leave-Pst-Mod-Comp think-Dec  
 'Peter thinks that Jane left.'
- c. Peter-un na-eke [<sub>CP</sub> Jane-i *ttana-ss-nya-ko*] mwul-ess-ta.  
 Top I-to Nom leave-Pst-Q-Comp ask-Pst-Dec  
 'Peter asked me if Jane left.'

As we will see in Chapter 5, Korean TP can be split into TP and AgrP: [<sub>TP</sub> [<sub>AgrsP</sub> [<sub>VP</sub> ]]]. Notice that Tense is posited above AgrP which is again split into Agr<sub>s</sub>P and Agr<sub>o</sub>P. Thus the following clause structure holds for Korean.

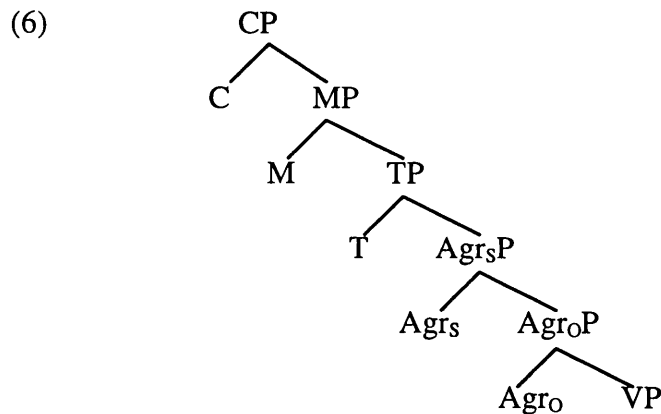

### 2.1.3. The Topic and Focus Positions in a Clause

According to Y.-S. Kim (1988), the Korean topic phrase appears below a wh-phrase in LF. I assume the wh-feature of the wh-phrase nwukwu-lul 'whom' in the



following sentence to raise to CP in overt syntax, based on the assumption that only the wh-feature<sup>2</sup> but not the whole wh-phrase in Japanese-type languages moves to C.

- (7) Kim-un ecey nwukwu-lul manna-ss-ni ?  
 Topic yesterday who-Acc meet-Pst-Q  
 ‘Whom did Kim meet yesterday ?’

If we assume the movement of a wh-feature to C, then the topic phrase cannot appear in [Spec,CP]. In this thesis, I propose that the wh-feature in Korean moves in C and the topic phrase occurs in [Spec,MP] (see Chapter 4 for this argument in detail). With this background, let us consider the following sentences.

- (8) a. [AgrSP John-i [AgrOP Mary-lul [VP po-ass-ta.]]  
 Nom Acc see-Pst-Dec  
 ‘John saw Mary.’
- b. [MP Mary<sub>i</sub>-nun [AgrSP John-i [AgrOP t<sub>i</sub> [VP po-ass-ta.]]]  
 Top Nom see-Pst-Dec  
 ‘As for Mary<sub>i</sub>, John saw her<sub>i</sub>.’

---

<sup>2</sup> Watanabe (1992) argues that wh-in-situ in Japanese in fact involves syntactic movement of an invisible entity. He supposes that Japanese interrogatives involve invisible syntactic movement.

Based on Watanabe’s (1992) idea of the invisible entity and Chomsky’s (1995) idea of feature movement, I suggest that in interrogative clauses in Korean (and Japanese), only the wh-feature of the lexical elements like nwukwu ‘who’, mwuet ‘what’, eti ‘where’ should move to C which contains a corresponding wh-feature, even though the interrogative pronouns themselves do not move but remain in situ. The difference between Korean and English is that Korean involves the movement of the wh-feature only, while English requires the movement of the whole wh-phrase including a wh-feature, namely pied-piping.

- c. [CP F<sub>j</sub> [MP Mary<sub>i</sub>-nun [AgrSP nwukwu<sub>j</sub>-ka [AgrOP t<sub>i</sub> [VP po-ass-ni ?]]]]  
   Top  who-Nom  see-Pst-Q  
   ‘As for Mary<sub>i</sub>, who saw her<sub>i</sub>?’

The topic phrase appears in [Spec,MP], as shown in (8b). In (8c) F indicates the invisible wh-feature of nwukwu ‘who’. If we assume the movement of an invisible wh-feature to C, the topic can appear in [Spec,MP].

Now let us turn to the [Spec,Agr<sub>S</sub>P] position. The phrase having the nominative case marker ‘i/ka’ appears in [Spec,Agr<sub>S</sub>P]. Let us compare the topic subject with the nominative subject. Notice that the topic subject appears in [Spec,MP] and the nominative subject in [Spec,Agr<sub>S</sub>P].

- (9) a. [AgrSP John-i [AgrOP Mary-lul [VP ttaly-ess-ta.]]]  
   Nom  Acc  hit-Pst-Dec  
   ‘John hit Mary.’ Or ‘It is John that hit Mary.’
- b. [MP John<sub>i</sub>-nun [AgrSP t<sub>i</sub> [AgrOP Mary-lul [VP ttaly-ess-ta.]]]]  
   Top  Acc  hit-Pst-Dec  
   ‘As for John<sub>i</sub>, he<sub>i</sub> hit Mary.’

Most Korean linguists (J.-Y. Yoon 1990, H.-S. Han 1987, G.-S. Moon 1987, and among others) agree that the nominative marker ‘i/ka’ indicates a contrastive FOCUS, as in (10a,b), while the TOPIC marker ‘un/nun’ refers to NON-FOCUS losing contrastiveness, as in (10c,d).

- (10) a. /  
   [John-i]  pwuca-ta.  
   Nom  rich-Dec  
   ‘John is rich’ or ‘It is John who is rich.’

/                      /

b. [Peter-ka] anila [John-i] pwuca-ta.  
       Nom not                Nom rich-Dec  
 ‘Not Peter but John is rich.’

/

c. John-un [pwucta.]  
       Topic be rich  
 ‘John is rich’ or ‘As for John, he is rich.’

/

d. \* [Peter-nun] anila [John-un] pwuca-ta.  
       Top not                Top rich-Dec  
 ‘Not Peter but John is rich.’

As the above examples indicate, the subject with the nominative marker ‘i’/’ka’ can be interpreted as having a contrastive FOCUS reading while the TOPIC subject cannot have a FOCUS reading. Notice that only the nominative subjective can receive a FOCAL stress (contrastive Focus stress) while the topic subject cannot. Concerning where the FOCUS subject and TOPIC subject appear (cf. Chapter 4), I propose that [Spec,Agr<sub>S</sub>P] is the position where the FOCUS subject can occur while [Spec,MP] is the position where the TOPIC element can appear (cf. J.-Y. Yoon 1990 and Y.-S. Kim 1988). Notice that the TOPIC element appears above the FOCUS subject.

/

(11) [John-un] [Mary-ka] salanghan-ta.  
       Top                Nom love-Dec  
 ‘As for John, Mary loves him.’

Then the structure in (12a) will be for (10a) and that in (12b) will be for (10c), respectively, as illustrated below.

(12)

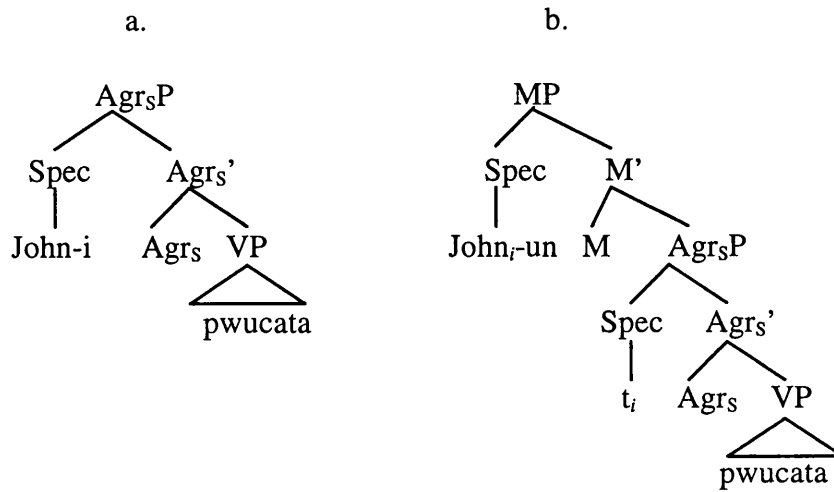

If we are on the right track, we may argue that in a Korean clause, the topic position is [Spec,MP] and [Spec,Agr<sub>S</sub>P] is a Focus position.

#### 2.1.4. The Topic and Focus Positions in the DP-Structure

In this Subsection, I assume that the DP-structure also contains a FOCUS position and a TOPIC position.

Szabolcsi (1990) argues that Noun Phrases contain a pre-determiner position, observing that in (13) the possessor Mari marked for dative case appears before the determiner. The example in (13) is reproduced from Szabolcsi (1990).

(13) [DP Mari-nak [ D<sup>0</sup> a [NP vendég-e-∅ ]]]  
Mary-Dat the guest-Poss-3Sg

Szabolcsi (1990) proposes that the NP Mari in (13) has moved to [Spec,DP] where it receives Dative Case, and points out that the movement is an instance of A'-movement.

A similar analysis can be applied to Korean.

- (14) a.  $[\text{DP } \text{Ku } \text{celmun } \text{namca}]$   
           the young man
- b.  $[\text{DP } [\text{Celmun}]_i \text{ } [\text{D}^0 \text{ku}] \text{ } [t_i] \text{ } [\text{NP } \text{namca}]]$   
               young           the           man

An attributive adjective can move to a position preceding its determiner<sup>3</sup>, that is, [Spec,DP].

Note that the pre-determiner position is an A'-position. The interpretation for (14a) is different from that of (14b) in that when the adjective appears in the pre-determiner position, [Spec,DP], as in (15b), the adjective loses FOCAL stress, as in (14b), but when the adjective occurs in [Spec,XP<sup>4</sup>], as in (15a), the FOCAL stress on the adjective is valid<sup>5</sup>, as illustrated in (14a).

---

<sup>3</sup> In Chapter 3, I will argue that the movement of an attributive adjective to the pre-determiner position is due to a NON-FOCUS feature.

<sup>4</sup> In fact, in Chapter 3, I propose that Korean adjectives and RCs are base-generated in [Spec,XP] in a DP structure like (15a), and that the XP is a functional category called Agreement Phrase (AgrP).

<sup>5</sup> See Chapter 3 for a detailed discussion of this kind of contrast between a focused adjective and a de-focused adjective.

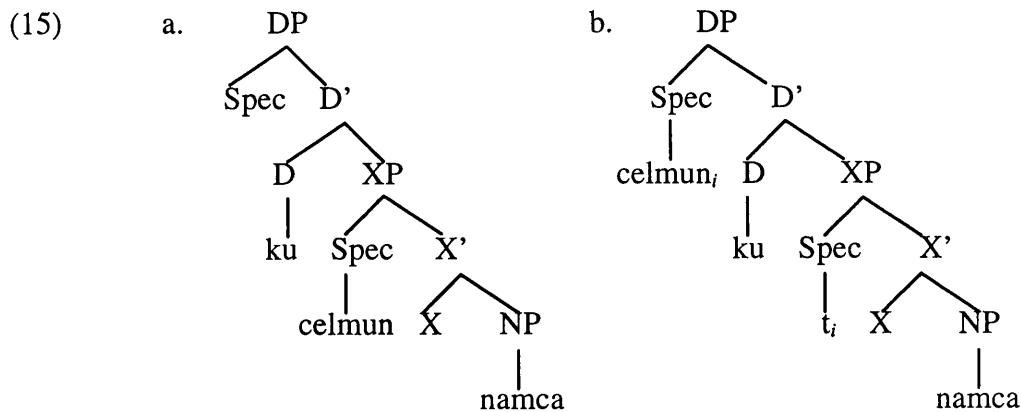

I propose that [Spec,DP] and [Spec,MP] are the positions where the de-focused (topic or non-focused) element can appear, while [Spec,XP] in the DP-structure (as in (15)) and [Spec,Agr<sub>S</sub>P] in the IP-structure (as in (12)) are the positions showing contrastive FOCUS.

### 2.1.5. Functional Categories between DP and NP

Ritter (1988) proposes that the Determiner is split into D(eterminer) and AGR(ement). Her analysis on noun phrases reminds us of the Split-Infl Hypothesis (Pollock 1989) where Infl is divided into two functional categories: Tense and Agreement. Since her analysis the existence and nature of DP-internal functional categories has attracted a lot of attention (Ritter 1988, 1990, Longobardi 1990, Piccalo 1990, Cinque 1990b, Szabolcsi 1983, 1990 and Carstens 1991).

Szabolcsi (1983) observes that in Hungarian possessive constructions, the possessor agrees with the head noun in person and number, and that the agreement markers are the same as those found on the subject of a verb (examples in (16) from Szabolcsi (1983)).

- (16) a. a te- $\emptyset$  titk-od  
the you(2.sg)-Nom secret-Poss.2sg  
‘Your secret’
- b. Te- $\emptyset$  ir-od  
you(2.sg)-Nom write-Pres.2sg  
‘You write.’

In (16), both the possessor and the subject bear the nominative morpheme, and both the head noun and the verb bear the 2.sg marker. Based on this, Szabolcsi (1983, 1987) concludes that Noun Phrases contain an Infl-like functional category following the determiner.

Ritter (1990) provides us with additional evidence for the existence of a functional category between D and N. Ritter (1990) argues that the additional functional category between D and N contains the number features of the Noun Phrase, and that the noun moves to the functional category.

In the next Section, I propose that Korean noun phrases also have an intermediate functional category called AgrP between DP and NP.

## 2.2. Functional Categories in Noun Phrases in Korean

I argue that Korean noun phrases contain two functional categories, namely, D(eterminer) and Agr(eement), as illustrated in (17) below.

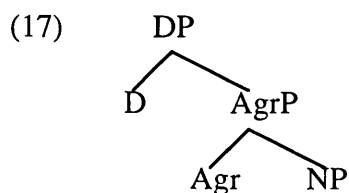

I contend that the pre-modifying adjective and the RC in Korean are base-generated in [Spec,AgrP]. In Subsection 2.2.2, I will show that there is an agreement feature checking between the pre-nominal modifier (pre-nominal adjective or relative clause) and its nominal head with respect to honorific and plural marking in Korean NPs.

With respect to the status of adjectives<sup>6</sup>, I follow the assumption that adjectives are specifiers; Jackendoff (1977) suggests that adjectives appear in the specifier positions of lexical categories and Cinque (1992) argues that adjectives are base-generated in the specifier position of functional categories. This thesis adopts Cinque's (1992) argument with respect to the status of pre-nominal adjectives.

Before discussing how the agreement feature checking between the adnominal modifier and its head noun works, let us first see how the agreement feature checking between the subject and the verb takes place in a clause.

---

<sup>6</sup> Of course, the status of attributive pre-nominal adjectives has been controversial. The proposals may be divided into two groups. The first group contends that the adjectives are base-generated in specifier positions (Jackendoff 1977 and Cinque 1992). The second group proposes that the adjectives are heads ( $X^0$ ); in Abney (1987) adjectives are assumed to take NPs as their complements, and in Valois (1991) adjectives are taken to adjoin to the head of Noun Phrase. The latter position is motivated on the grounds that the adjectives and nouns in Romance and Germanic exhibit rich agreement. But in the case of Korean noun phrases agreement holds with the relative clause as well as pre-nominal adjective. This means that even though the adjective is  $X^0$  and therefore may adjoin to  $N^0$  (or heads), relatives surely cannot be  $X^0$  but must be XP. Given this, we can argue that the adnominal modifiers showing agreement with the head noun are not  $X^0$  but XP and should then appear in the specifier positions. In addition, note that Jackendoff's conception of a specifier is not the standard one so that when he says adjectives are specifiers he saying something quite different from Cinque.



### 2.2.1. Honorific and Plural Agreement in Clauses

In Korean we can see two agreement phenomena between subject and verb: Honorification and Number agreement.

Let us first consider honorification agreement between subject and verb (see H.-S. Choe 1988, H.-S. Han 1987, Shibatani 1977, and J.-Y. Yoon 1990 for details). The examples are from J.-Y. Yoon (1990).

- (18) a. *Apeci-kkese*<sup>7</sup>            *o-si-ess-ta.*  
Father-Hon+Nom    come-Hon-Pst-Dec  
'My father came.'
- b. ??? *Apeci-kkese*            *o-ass-ta.*  
father-Hon+Nom    come-Pst-Dec
- c. John-i    *apeci-eke ka-ass-ta.*  
Nom father-to go-Pst-Dec  
'John went to his father.'
- d. \* John-i    *apeci-eke ka-si-ess-ta.*  
Nom father-to go-Hon-Pst-Dec
- e. John-i    *apeci-lul pwulu-ess-ta.*  
Nom father-Acc call-Pst-Dec  
'John called his father.'
- f. \* John-i    *apeci-lul pwulu-si-ess-ta.*  
Nom father-Acc call-Hon-Pst-Dec

In the above sentences, we can see the honorific agreement between the subject and the verb; the honorific marker *si* is licensed by the subject. This honorification is

---

<sup>7</sup> 'Kkese' is variant of the subject case marker 'i/ka'. This 'kkese' is used only when the subject is higher than the speaker in social status.

operative only when the subject is higher in social status than the speaker. The honorific agreement in (18) is an instance of subject-verb agreement.

Secondly, according to J.-Y. Yoon (1990), number agreement in Korean is not obligatory but optional. However, if the plural marker *tul* appears in the predicate, it should be matched with a plural subject, as illustrated in the following examples which I reproduce from J.-Y. Yoon (1990).

- (19) a. Haksayng-*tul* -i ppali tale-(*tul*) o-ass-ta.  
student-Pl-Nom quickly run-Pl come-Pst-Dec  
'Students came very quickly.'
- b. \* Haksayng-i ppali tale-*tul* o-ass-ta.  
student-Nom quickly run-Pl come-Pst-Dec
- c. Nehee-*tul* cal ka-kela-(*tul*).  
You-Pl well go-Imp-Pl  
'You (Pl), Goodbye.'
- d. \* Nehee cal ka-kela-*tul*.  
You well go-Imp-Pl  
'You (Sg), Goodbye.'

As the above examples indicate, *tul* is licensed by a plural subject. From these observations, we can conclude that there is AGR<sup>8</sup> in Korean clauses.

---

<sup>8</sup> J.-Y. Yoon (1990) claims that the morphological realisation of AGR is different from language to language, depending on the prominence among the AGR features; for example, in Korean and Japanese the honorific and number AGRs are prominent, whereas in English the person and number AGRs are prominent.

### 2.2.2. Honorific and Plural Agreement in Noun Phrases

Honorific and number agreement can be observed not only in clauses but also in noun phrases (examples from J.-Y. Yoon 1990).

- (20) a. *Sensayng-nim-uy eme-nim*<sup>9</sup>  
teacher-Hon-Gen mother-Hon  
'teacher's mother'
- b. \* *Hain-uy eme-nim*  
servant-Gen mother-Hon  
(Lit.) the servant's mother'
- c. *Sonnim-tul-uy tochakkwangkyeng-tul*  
guest-Pl-Gen arrival scene-Pl  
'the scenes of the guests' arrival'
- d. \* *Han sonnim-uy tochakkwangkyeng-tul*  
one guest-Gen arrival scene-Pl  
'(the scenes of one guest's arrival)'

According to J.-Y. Yoon (1990), in (20) the occurrence of the honorific marker *nim* between the genitive NP and its head NP indicates that there is honorific agreement in noun phrases. Since in (20a) the genitive noun *sensayngnim* 'teacher' is socially superior to the speaker, the head noun contains the honorific marker *nim*. By contrast,

---

<sup>9</sup> *Nim* is an honorific marker for noun phrases. This honorific marker *nim* is different from the honorific marker *si* which is attached only to a predicate.

- (i) *Apeci-kkese o-si-n-ta.*  
Father-Nom+Hon come-Hon-Prog-Dec  
'Father is coming.'
- (ii) *Emeni-kkese alumtawu-si-ta.*  
Mother-Nom+Hon beautiful-Hon-Dec  
'Mother is beautiful.'

since in (20b) the genitive NP *hain* ‘servant’ is socially inferior to the speaker, the usage of the honorific marker *nim* results in a violation of honorific agreement and therefore an ungrammatical derivation. As the examples in (20c-d) reveal, number agreement is also needed in noun phrases, just as in clauses. In (20c) both the genitive DP and its head N are plural and they are plural-marked, as expected. But in (20d) the genitive NP is singular and the head noun contains the plural marker, violating number agreement.

Furthermore, we can observe that there is honorific agreement between the pre-modifying adjective (or RC) and its head noun. The honorific marker is optional in the pre-nominal modifying adjective, as in (21) and (22) below. I reproduce the examples in (21) from J.-Y. Yoon (1990)

- (21) a. [DP Ku [AP emha-(*si*)-n] [NP sensayng-*nim*-i]] o-si-ess-ta.  
the strict-Hon-AM teacher-Hon-Nom come-Hon-Pst-Dec  
‘The strict teacher came.’
- b. \*[DP ku [AP emha-*si*-n] [NP chinkwu-*nim*-i]] o-si-ess-ta.  
the strict-Hon-AM friend-Hon-Nom come-Hon-Pst-Dec  
‘The strict friend came.’
- c. \* [DP ku [AP emha-*si*-n] [NP chinkwu-ka]] o-ass-ta.  
the strict-Hon-AM friend-Nom come-Pst-Dec  
‘The strict friend came.’
- d. [DP [RC Mikwukuk-ey sa-si-nun] ku [NP ape-*nim*]]  
America-Loc live-Hon-AM the father-Hon  
‘The father, who lives in America’
- e. \* [DP [RC Mikwukuk-ey sa-si-nun] ku [NP chinkwu-*nim*]]  
America-Loc live-Hon-AM the friend-Hon  
‘The friend, who lives in America’

- (22) a. [RC Seoul-ey ka-(*si*)-n] [NP ape-*nim*]  
Loc go-Hon-AM father-Hon  
‘My father who went to Seoul’

- b. \* [<sub>RC</sub> Seoul-ey ka-si-n] [<sub>NP</sub> chinkwu]  
 Loc go-Hon-AM friend  
 'My friend who went to Seoul'

In (21) and (22) the occurrence of the honorific marker *si* on an adjective (or on a RC) and of *nim* on the head noun shows that there is honorific agreement between a pre-nominal modifying adjective (or an RC) and its head noun. The honorific marker is attached to the adjective only when the adjective modifies a head noun whose referent is superior to the speaker.

Given that there is agreement in Korean noun phrases, it is natural to suppose that there is a functional category called Agr(eement) Phrase in DP, just as assumed in clauses. Since the determiner appears before the whole Adj+NP, as seen in (21)-(22), the AgrP should be located immediately after the determiner. I therefore suppose that the AgrP in DP appears between D<sup>0</sup> and N<sup>0</sup>, as illustrated in (23) below.

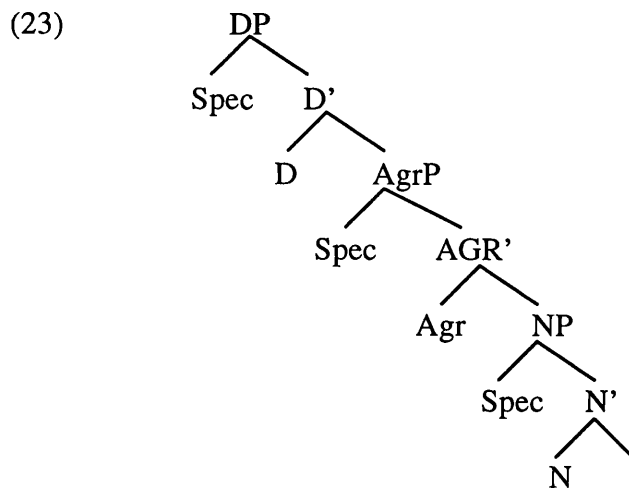

## 2.3. The Position of Adnominal Modifiers

### 2.3.1. The Nature of Pre-nominal Adjectives and RCs

In this Subsection, I suggest that Korean (and Japanese) relative clauses and pre-nominal modifying adjectives have a similar position [RC or Pre-nominal adjective + AM<sup>10</sup> marker + Noun] and the same function (i.e. modifying the nominal).

Relative clauses have the AM marker, as shown in (25); other subordinate clauses do not have the AM marker, as seen in (24) (Y.-K. Kim 1996).

- (24) a. [Mary-ka John-ul salanghan-ta *myen*] nay-ka ttenakess-ta.  
Nom Acc love-Dec if I-Nom will leave-Dec  
'If Mary loves John, I will leave.'
- b. [Mary-ka John-ul salanghan-ta *ko*] na-nun saynggakhant-ta.  
Nom Acc love-Dec that I-Top think-Dec  
'I think that Mary loves John.'
- c. [Mary-ka pap-ul mekul *ttae*] na-nun cako-iss-ess-ta.  
Nom rice-Acc eat when I-Top sleep-be-Pst-Dec  
'When Mary ate boiled rice, I was sleeping.'
- (25) a. [nay-ka salangha-*n*] namca  
I-Nom love-AM man  
'(the) man whom I love'
- b. [Na-lul salangha-*n*] namca  
I-Acc love-AM man  
'(the) man who loves me'

---

<sup>10</sup> There are assumed to be four AM markers linking RCs and their head nominal: '*nun*', '*(u)n*', '*(u)l*', and '*ten*'; see H.-S. Lee (1991) for details of the four AM markers. For pre-nominal adjectives, '*(u)n*' only is used as the AM marker.

When an adjective is used as a pre-nominal attributive modifier, it takes the same AM marker as the relative clause, as in (27); when it is used as a predicate, as shown in (26), it does not have the AM marker but the sentence declarative ending, *ta*.

(26) a. Ku kkot-i            yeppu-*ta*.  
the flower-Nom        pretty-Dec  
'The flower is pretty.'

b. Ku namca-ka        yengriha-*ta*.  
the man-Nom            clever-Dec  
'The man is clever.'

(27) a. Ku yeppu-*n* kkot  
the pretty-AM flower  
'The pretty flower'

b. Ku yengriha-*n* namca  
the clever-AM        man  
'The clever man'

Some Japanese adjectives (*-na* adjectives) exhibit the same phenomenon. When they are used as predicates, the sentence ender, *-da*, is attached. When they are used as pre-nominal modifiers, on the other hand, the *-na* morpheme is attached sharing an alternation similar to that of the Korean adjective.

(28) a. Ano hana-ga kirei-*da*.  
that flower pretty-Dec  
'That flower is pretty.'

b. Ano kirei-*na* hana  
that pretty-AM flower  
'That pretty flower'

This observation supports our analysis that the RC and pre-nominal adjective in Korean and Japanese have the same position and function, resulting in the same word order [Modifier + AM + head nominal].

Korean relative clauses with their head nouns can be represented as having the structure, ‘RC + AM + Head noun.’ Korean pre-nominal modifying adjectival constructions also have the same structure, i.e. ‘Pre-nominal Adjective + AM + Head noun’. Now we can generalise ‘Adnominal Modifier + AM + Head noun’.

- (29) a (ku) [<sub>RC</sub> nay-ka cohaha-*nun*] yeca  
           the I-Nom like-AM woman  
           ‘(the) woman whom I like’
- b. (Ku) [<sub>AP</sub> yepp-*un*] yeca  
           the pretty-AM woman  
           ‘(the) pretty woman’

With respect to the position of where the adnominal modifier appears, it is my argument that both the relative clause and the pre-nominal attributive adjective in Korean are base-generated in the same position preceding the head nominal and following the determiner.

### 2.3.2. The Nature of AM Markers

Based on H.-S. Lee’s (1991) argument that the AM which links the adnominal modifier and its nominal head is not a tense marker, but an aspectual morpheme indicating either ‘*perfective*’ or ‘*imperfective*’ aspect of an adnominal modifier, I propose that the RC having an aspectual (perfective/imperfective) feature is merged into the specifier position of AgrP, and after the head noun is adjoined to Agr<sup>0</sup>, the agreement feature checking takes place.



### 2.3.2.1. Aspect

According to Smith (1991), there are two ways of looking at the aspectual structure of a described situation. The first way is to see the inherent aspectual properties of situations; the other is concerned with how the speaker views a situation. A situation can be presented differently depending on the speaker's viewpoint. In this Section, I will pay attention to and discuss the second way.

The speaker's aspectual viewpoint of a described situation can again be divided in two: temporal viewpoint vs. totality viewpoint. In temporal viewpoint a situation is located depending on the temporal location of the speaker's viewpoint. According to this temporal viewpoint, aspect can be divided into 'non-completed' and 'completed' aspect. If so, '*nun*' refers to 'non-completed' action (aspect) while '*(u)n*' indicates 'completed' action (aspect), as illustrated in (30) below.

- (30) a. [Ce cip-ul cis-*nun*] John  
that house-Acc build-AM  
'John who is building that house'
- b. [Ce cip-ul ci-*un*] John  
that house-Acc build-AM  
'John who (has) built that house'

On the other hand, the totality view is another way to appreciate the speaker's aspectual viewpoint of a situation in terms of perfectivity (perfective or imperfective). According to Smith (1991), the totality view of aspect is concerned with whether a situation is viewed from outside (external view) as a single conceptual unit or viewed from inside (internal view). If the situation is externally appreciated, the perfective aspect is chosen; if it is internally viewed, the imperfective aspect is chosen.

Based on Comrie (1976) and Smith (1991), H.-S. Lee (1991) argues that the AM marker in Korean adnominal modifiers indicates the perfective or imperfective aspect of an adnominal modifier; ‘(u)n’ refers to perfective aspect (external view) of a adnominal modifier while ‘nun’ indicates imperfective aspect (internal view) of the modifier. In this thesis, I follow H.-S. Lee’s (1991) argument with respect to the status of the AM in Korean adnominal modifiers.

### 2.3.2.2. The Totality View of Perfectivity

Let us consider the notion of perfectivity, by taking examples (from H.-S. Lee (1991)).

- (31) [RC cekise cacenke-lul tha-n] sonye-ka ililo on-ta.  
 over there bicycle-Acc ride-AM girl-Nom this way come-Dec  
 ‘A girl *on a bike* is coming this way.’

According to H.-S. Lee (1991), in (31) tha-n ‘riding’ refers to a current state of affairs (of being on a bike) rather than a completed action (i.e. having ridden a bike). The reason why tha-n in (31) should be interpreted as a current state of affairs rather than a completed action cannot be accounted for in terms of the temporal view (completeness). Notice that in the temporal view of aspect, ‘(u)n’ indicates the completed action or state; ‘nun’ refers to the non-completed (progressive) action. On the other hand, in the totality view of perfectivity, stative cannot take the imperfective aspectual morphology ‘nun,’ since the situations described by stative verbs or adjectives do not have an internal view, and thus cannot be expressed with the imperfective form ‘nun’. Recall that in (31) tha-n ‘riding’ is interpreted as a current state of affairs and not as an action, and does not allow the situation to have

an internal view. Therefore, the totality view of perfectivity can account for why the verb in the relative clause in (31) must take the perfective form ‘(u)n,’ even though the situation is not a completed action. If the temporal view of aspect is chosen for the interpretation of the relative clause in (31), tha-n cannot be interpreted as a current state of affairs (being on a bike), since in the temporal view, ‘(u)n’ should refer to a completed action. This observation shows us that with regard to the definition of perfectivity and the exclusive usage of the perfective morphology ‘(u)n’ in the statives, the totality view of aspect has advantages over the temporal view of aspect.

### 2.3.2.3. Aspect in RCs and Pre-nominal Adjectives

Korean relatives and attributive adjectives show a contrast between *perfective* and *imperfective* aspect. According to the totality viewpoint of aspect (H.-S. Lee, 1991), the perfective aspect views a situation as a ‘wrapped single entity’ and the imperfective aspect appreciates a situation as ‘unfolding as it happens’. In this Subsection, I examine how the totality view of perfectivity is expressed in relative clauses and pre-nominal modifying adjectives in Korean.

As seen above, the distinction between perfective and imperfective is expressed by different suffixing: ‘(u)n/nun’. ‘(u)n’ refers to perfective aspect while ‘nun’ indicates imperfective, as illustrated in (32), (33) and (34) below.

- (32) a. [Seoul-ey ka-**n**] John                      a'. [Seoul-ey ka-**nun**] John  
           Loc go-AM                                      Loc go-AM  
           ‘John who has gone to Seoul’            ‘John who goes/is going to Seoul’
- b. [i cip-eyse cam-ul ca-**n**] Mary              b'. [i cip-eyse cam-ul ca-**nun**] Mary  
       this house-in sleep-Acc sleep-AM        this house-in sleep-Acc sleep-AM  
       ‘Mary who (has) slept in this house’    ‘Mary who (is) sleep(ing) in this house’

(33) Ku-nun yepp-un /\* nun cip-ul kacy-ess-ta.  
 He-Top pretty-AM house-Acc have-Pst-Dec  
 'He has a pretty house.'

(34) ku-nun cak-un /\*nun son-ul kacy-ess-ta.  
 He-Top small-AM hand-Acc have-Pst-Dec  
 'He has small hands.'

To put it succinctly, the aspect of RCs and attributive adjectives is determined by the totality viewpoint of the situation but not by the temporal viewpoint of the situation.

The totality viewpoint of aspect can account for the fact that stative adjectives in Korean cannot co-occur with the progressive (imperfective) aspectual morpheme, '*nun*,' but can appear with the non-progressive (perfective) aspectual morpheme, '*(u)n*,' when they are used as modifying the nominal.

In the totality viewpoint of aspect, statives are taken as perfective, since states do not have an internal view. Situations described by stative predicates are always interpreted as an unanalyzable whole. This means that the situations marked by statives have nothing to do with time reference.

From these observations, H.-S. Lee (1991) argues that the AM marker in Korean is not a tense marker but an aspectual marker presenting the perfectivity of adnominal modifiers in term of the totality viewpoint. In this thesis, following H.-S. Lee (1991), I propose that the RC and pre-nominal adjective occur in [Spec,AgrP], to check their aspectual feature (perfectivity) with the corresponding feature borne by Agr<sup>0</sup>.

### 2.3.3. The Structure of Pre-nominal Adjectives and RCs

Given the structure for Korean noun phrases presented in Section 2.2, I propose that there is a functional category called AgrP (within DP) mediating the agreement features between pre-nominal adjectives (or RCs) and their head noun; the features of AgrP require the merger of a pre-nominal adjective or an RC into the specifier position of AgrP, and the head noun in  $N^0$  moves to the  $Agr^0$  position to check its features against the corresponding features occurring in [Spec,AgrP]. The positing of the functional category AgrP between DP and NP makes it possible to have agreement in plural or honorific feature between the adjective (or RC) in [Spec,AgrP] and the head noun<sup>11</sup> adjoined to  $Agr^0$ . Then (35) will have (36) as its structure.

- (35)      Ku    [<sub>AP</sub> kunemha-si-n]            imkum-nim  
           the        dignified-Hon-AM        king-Hon  
           ‘the dignified king’

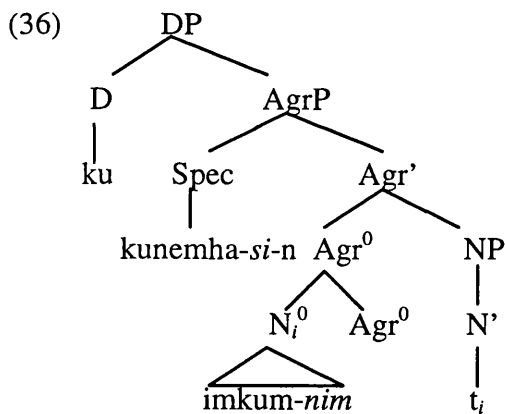

<sup>11</sup> I simply assume that  $N^0$  moves to  $Agr^0$  to check the agreement features between the adnominal modifier and the head noun adjoins to  $Agr^0$ , only when an adnominal modifier (RC or pre-nominal adjective) appears in [Spec,AgrP].

Let us turn to the case of a Korean relative clause and its structure<sup>12</sup>, as illustrated

in (37) and (38), respectively.

- (37) Ku [RC nay-ka mo-si-ess-ten] cangkwun-nim  
 the I-Nom serve-Hon-Pst-AM general  
 'the general whom I had served'

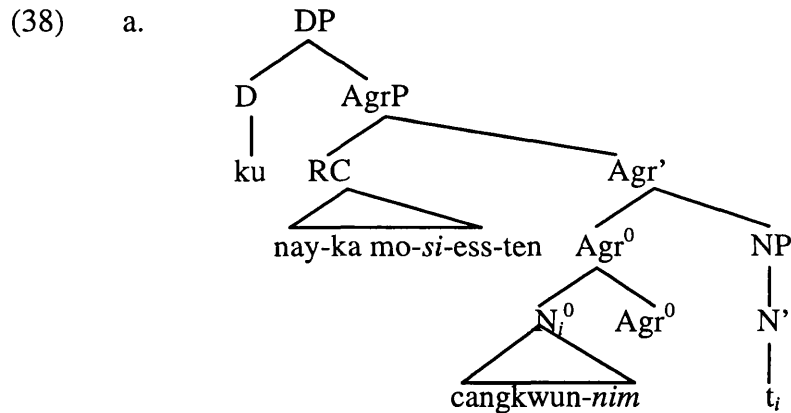

To sum up, pre-nominal adjectives and RCs in Korean have the same structure: they (pre-nominal adjective and RCs) are base-generated in [Spec,AgrP] and their head noun is base-generated in N<sup>0</sup> and raises to Agr<sup>0</sup> to check the agreement features thereby agreeing with the adnominal modifiers base-generated in [Spec,AgrP].

## 2.4. The Movement of the External Genitive Argument

Let us consider the following examples (from J.-Y. Yoon 1990).

- (39) a. [DP [DP Ku yamanin-uy] [D<sup>0</sup> [AgrP mwusewun [NP kongkyek]]]]  
 the barbarian-Gen terrible attack  
 '\* the terrible attack by a barbarian'  
 'the terrible attack by the barbarian'

<sup>12</sup> I will return to this matter later in Subsection 3.3.

- b. [DP [yamanin-uy] [D<sup>0</sup> [AgrP mwusewun [NP kongkyek]]]]  
 barbarian Gen terrible attack  
 ‘a terrible attack by a barbarian’
- c. [DP [D<sup>0</sup> Ku [AgrP mwusewun [NP kongkyek]]]]  
 the terrible attack  
 ‘the terrible attack’

In (39a) the determiner ku ‘the’ cannot modify the head noun kongkyek ‘attack’ but rather must modify the genitive noun yamanin ‘barbarian’. I suggest that the genitive DP ku yamanin-uy in (39a) occurs in the specifier position of the outer DP. If an adjective can intervene between the genitive noun yamanin-uy and its head noun kongkyek, the pre-nominal adjective is assumed to appear in [Spec,AgrP] between DP and NP. This implies that the genitive noun in (39a,b) cannot appear in [Spec,NP] since it occurs preceding the adjective. I assume that the genitive NP in (39a,b) is base-generated as the subject argument of the head noun in [Spec,NP] and moves up to the pre-determiner position. Indeed, if the genitive NP is base-generated in [Spec,NP] as the subject of N<sup>0</sup>, it should move up to a higher position (or some functional category) to check its genitive case feature. [Spec,DP] is the position where genitive case checking is available. [Spec,AgrP] is excluded since it has already been occupied by the attributive adjective mwusewun ‘terrible’, as seen in (39a,b).

In short, the external subject genitive NP cannot remain in [Spec,NP] and therefore moves to [Spec,DP] to check the genitive case borne by D<sup>0</sup> by its corresponding genitive case, just as the subject NP in [Spec,VP] should move to [Spec,Agr<sub>S</sub>P] to check its nominative case feature.

## 2.5. The Movement of N<sup>0</sup> in Num-Cl Constructions

This Section concerns the movement of the head noun N<sup>0</sup> in Korean Numeral-Classifier (Num-Cl) constructions in the DP-hypothesis. I argue that: (i) the Korean Numeral-Classifier is a kind of Quantifier which selects the head noun, and (ii) the head noun itself may move up to D<sup>0</sup> due to a specificity feature (Mahajan 1990) of the head noun.

### 2.5.1. The Movement of the Head Noun in Korean Num-Cl Constructions

A. Kim (1995) characterises a [Numeral + Classifier] sequence in Korean as a Quantifier Phrase.

(40) [QP Numeral + Classifier]

- (41) a. [DP [NP Chayk] [QP twu kwon]]  
           book       two CL  
           'two books'  
       b. \* [twu] [NP chayk] [kwon]  
               two     book CL

With respect to the structure of the Num-Cl in Korean, the Num-Cl (QP) constructions in Korean, are selected by D<sup>0</sup>; AgrP can occur between DP and QP, as illustrated in (42).

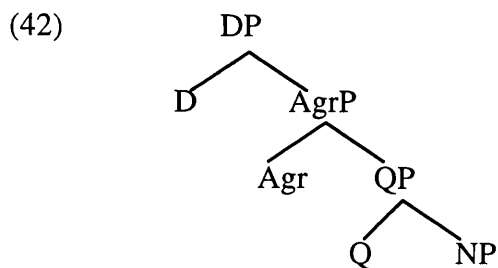



The following examples show that the head nominal in Num-Cl constructions cannot take the determiner, when the nominal appears before QP.

- (43) a. [DP (\* i) [NP chayk [QP twu kwon ]]]  
           (this) book two-Cl  
           ‘(these) two books’
- b. [DP (\* i) [NP so [QP twu mari ]]]  
           (this) cow two-Cl  
           ‘(these) two cows’ or ‘two heads of cows’
- c. [DP (\* i) [NP cip [QP yel-chay ]]]  
           (this) house ten-Cl  
           ‘(these) ten houses’

This phenomenon leads us to think of a movement analysis of the head noun: the movement of Noun to Determiner. The absence of the determiner in (43) is attributable to the movement of the noun to the determiner position. N<sup>0</sup>-to-D<sup>0</sup> movement can be found in some European languages.

- (44) a. [DP Hus<sub>i</sub>-et [NP t<sub>i</sub> ]] (Danish)  
           house-the
- b. [DP Omu<sub>i</sub>-l [NP t<sub>i</sub> ]] (Romanian)  
           house-the
- c. [DP Kudo<sub>i</sub>-S' [NP t<sub>i</sub> ]] (Mordvian)  
           house-the
- d. [DP Mendi<sub>i</sub>-a [NP t<sub>i</sub> ]] (Basque)  
           house-the

This analysis for European languages is advanced by Delsing (1988) and Taraldsen (1990). However, when an attributive adjective intervenes between the determiner and the head noun, the head noun cannot raise to the determiner, as the Danish examples show in (45) below:

- (45) a. Hus-et  
house-the
- b. Det gamle hus  
the old house
- c. \* Hus-et gamle

Delsing assumes that the noun in (45a) is raised from  $N^0$  to  $D^0$ . In (45b) the raising is prohibited because the adjective gamle 'old' is present, blocking the raising. The article Det 'the' is only found when an adjective intervenes.

Longobardi (1991) also assumes that proper names may raise from  $N^0$  to  $D^0$  in some languages. In this way, he explains why an article (determiner) is obligatory when the phrase contains an adjective, as in (46)-(47).

- (46) a. Gianni (Italian)
- b. Il simpatico Gianni  
the sympathetic Gianni
- (47) a. Johann (German)
- b. Der sympathische Johann  
the sympathetic Johann

The same phenomenon can be seen in Korean Numeral-Classifier constructions. Only when an intervening pre-nominal adjective or RC appears between DP and NP, as shown in (48) below, can the determiner appear. It is probable that the pre-nominal adjective or an RC preceding the head noun also prevents the head noun from raising to the D<sup>0</sup> position in Korean also, just as the intervening adjective prevents the head noun from moving to the determiner position as in (46)-(47). In contrast, when a pre-nominal adjective or an RC does not intervene between DP and NP, the head noun N<sup>0</sup> can move to the determiner position, as shown in (49). Notice that the determiner cannot be present with the head noun N<sup>0</sup>.

- (48) a. [DP (i)            [AgrP [AP ku-n] [sayngsun] [QP twu mari]]]  
           this                    big-AM    fish            two-Cl  
           ‘(these) two big fish’
- b. [DP (ce)            [AgrP [RC elwuk iss-nun] [so] [QP se mari]]]  
           that                    spot be-AM            cow            three-Cl  
           ‘(those) three cows that have some spots’
- c. [DP (i)            [AgrP [AP pulk-un] [cip] [QP yel chay]]]  
           this                    red-AM            house    ten-Cl  
           ‘(these) ten red houses’
- (49) a. [DP sayngsun<sub>i</sub> [QP twu mari [NP t<sub>i</sub>]]]  
           fish                    two-Cl  
           ‘two fish’
- b. [DP so<sub>i</sub> [QP se mari [NP t<sub>i</sub>]]]  
           cow            three-Cl  
           ‘three cows’
- c. [DP cip<sub>i</sub> [QP yel chay [NP t<sub>i</sub>]]]  
           house    ten-Cl  
           ‘ten houses’

It remains for us to determine what the position of sayngsun ‘fish,’ so ‘cow,’ or cip ‘house’ in (48) above is. Notice that even though the head nominal  $N^0$  cannot move to  $D^0$  when an adnominal modifier (RC or pre-nominal adjective) appears, the noun  $N^0$  can appear before QP, as seen in (48). With respect to the position of the head noun, I propose that it is simply  $Agr^0$  to which  $N^0$  moves. Recall that in 2.3.3, when the adnominal modifier appears in [Spec,AgrP], the head noun  $N^0$  moves to  $Agr^0$  to check the agreement features between them.

If we assume that QP is base-generated preceding NP, the S-Structure for (50a) must be (51b).

- (50) a. [NP yeca] [QP twu myeng ]  
           woman two Cl  
           ‘two women’
- b. \* Ku [NP yeca [QP twu myeng]]  
           the woman two Cl
- (51) a. [NP [ $N^0$  yeca] [QP twu myeng]]  
           woman two Cl
- b. [DP [ $D^0$  [ $N^0$  yeca<sub>i</sub>]] [QP twu myeng [NP t<sub>i</sub>]]]  
           women two Cl  
           ‘two women’

If the head nominal yeca ‘woman’ in (50a) is base-generated preceding twu myeng ‘two-Cl’ without movement, as in (51a), we cannot account for why the form [Noun + [QP]] cannot take the determiner, as seen in (50b). If we assume the movement of the head noun to  $D^0$ , as in (51b), we can explain why the form [Noun + QP] does not take the determiner; that is, once the head noun moves to  $D^0$ , filling the D-position, just as in the movement of proper noun (name) to  $D^0$  in Italian or German, the

determiner cannot be inserted in the  $D^0$ -position. In addition, the movement analysis can account for the base-generated word order [QP + NP].

Now a question arises: what makes the head nominal (in Num-Cl constructions) move up to  $D^0$  ? Based on Mahajan<sup>13</sup> (1990) and Bhattacharya<sup>14</sup> (1996), I assume that

---

<sup>13</sup> In Mahajan (1990) a syntactic definition of specificity is given, as follows:

- (i) a. Objects can be Case-marked either by V or by Agr<sub>o</sub>.
- b. Non-specific objects receives Case from V within the VP while specific objects are Case-marked by Agr<sub>o</sub>.
- c. Specificity Filter: Only specific DPs can (and must) be Case-marked by Agr while non-specific DPs must be Case-marked in some other way.

According to this analysis, the movement of the object to [Apec,AgroP] is possible because of the specificity effect.

<sup>14</sup> Based on Mahajan (1990), Bhattacharya (1996) also makes use of specificity in analyzing the movement of Num-Cl in Bangla. With regards to what drives the leftward NP-movement, Bhattacharya (1996) proposes that a presuppositional/specific feature of the Q head drives leftward movement of the NP, as in (i). The moved object gives a specific reading, as the English translation in (i) indicates.

- (i) [QP [NP *boi* ]<sub>i</sub> [Q du-To] t<sub>i</sub> ] dekhechi  
       book       two-Cl       seen  
       'I have seen the two books'
- (ii) ami [ du-To [ *boi* ] ] dekhechi  
       I       two-Cl   book    seen  
       'I have seen two books'

the head noun in the Num-Cl constructions moves up to  $D^0$  due to a specificity feature of the head noun<sup>15</sup>;  $D^0$  is assigned a strong and [-Interpretable] specificity feature during the derivation. If so, the strong [-Interpretable] specificity feature of  $D^0$  should be checked and deleted against the corresponding feature borne by the head  $N^0$  moved to  $D^0$  before Spell-Out. If this is on the right track, the movement of the head nominal in Num-Cl constructions such as (49) and (51b) is due to a specificity feature of the head noun.

---

<sup>15</sup> Let us consider the following examples:

(i)  $[_{DP} [_{D^0} [_{N^0} \text{khong}]_i [_{QP} \text{se pwutay} [_{NP} t_i ]]]] \text{ cwuseyo.}$   
           bean           three-Cl(bag)           give me  
           ‘Please give me three bags of beans.’

(ii)  $[_{DP} [_{D^0} \text{ce} [_{AgrP} \text{palan} [_{Agr^0} [_{N^0} \text{khong}]_i ] [_{QP} \text{se pwutay} [_{NP} t_i ]]]]] \text{ cwuseyo.}$   
           that   blue           bean           three-Cl (bag)           give me  
           ‘Please give me three bags of those blue beans.’

The semantic difference of khong between (i) and (ii) lies in the specificity of khong: khong in (i) is indefinite but specified while that in (ii) is not specified. The modifying adjective palan ‘blue’ specifies the referent of khong in (ii). If a customer says sentence (i) to a shop assistant, he assumes that the assistant knows what kind of beans he wants. In contrast, when sentence (ii) is uttered, the customer assumes that the assistant does not know what kind of beans he wants, and so he specifies the referent of beans that he wants to buy by adding a pre-nominal adjective.

In short, a nominal element with a specificity<sup>16</sup> feature moves out of its base-generated position to some higher position. Following this argument, I propose that the head noun (in Num-Cl constructions) bearing a specificity feature moves out of its original position to  $D^0$  to check its specificity feature against a corresponding feature borne out by  $D^0$ .

---

<sup>16</sup> In Chapter 5, I present a similar analysis: in double nominative constructions, the first specific NP moves out of its original position to [Spec,ArgsP] but the non-specific second NP does not involve movement, but remains in situ within the VP having default (inherent) case. This argument can be accommodated into the general assumption that a specific noun (object) should move out of its base-generated position (out of VP) and raise to some higher functional category while a non-specific noun (object) should remain in situ (cf. Mahajan 1990).

## CHAPTER 3

### THE MOVEMENT OF NON-RESTRICTIVE ADNOMINAL MODIFIERS

The purpose of this chapter is to characterise the major differences between restrictive and non-restrictive relative clauses (more generally speaking, the differences between restrictive and non-restrictive adnominal modifiers), and show that the non-restrictive adnominal modifiers should move to [Spec,DP] out of the scope of its determiner in overt syntax or in LF to receive a proper interpretation.

In Section 3.1, I sketch the basic properties of restrictive and non-restrictive adnominal modifiers.

In Section 3.2, I propose that the restrictive adnominal modifier and the non-restrictive adnominal modifier both have the same underlying structure, and that only the non-restrictive adnominal modifier moves to the pre-determiner position. The movement of the non-restrictive adnominal modifier is done in LF in English while in overt syntax in Korean.

Section 3.3 is devoted to a discussion of previous analyses of RCs. I criticise the analysis of Kayne's (1994) [D<sup>0</sup> CP] structure for RCs in N-final languages such as Japanese and Korean, and propose an alternative structure for RCs as well as pre-nominal adjectives in Korean (cf. Chapter 2).

In Section 3.4, I examine the function of the FOCUS feature in restrictive adnominal modifiers (RAM) and of the NON-FOCUS feature in the non-restrictive adnominal modifier (NAM). I argue that the movement of the non-restrictive modifier



to [Spec,DP] is due to the NON-FOCUS feature of the determiner and the non-restrictive adnominal modifier. The determiner having a NON-FOCUS feature attracts the non-restrictive adnominal modifier (which is base-generated in [Spec, AgrP] occurring between DP and NP) to check its NON-FOCUS feature against the corresponding feature borne by the non-restrictive adnominal modifier.

In Section 3.5, I argue that Internally Headed Relative Clauses (IHRCs) in Korean are a kind of non-restrictive relative clause, and therefore they should appear in [Spec,DP].

### 3.1. The Notion of Restrictiveness

With respect to the difference between Restrictive Relative Clauses (RRCs) and Non-restrictive Relative Clauses (NRCs), Comrie (1989) says:

“The restrictive clause serves to delimit the potential referents of the man, in ‘*the man that I saw yesterday left this morning*’. The speaker assumes that the sentence the man left this morning does not provide the hearer with sufficient information to identify the man in question (the hearer would probably have to ask *which man*), so the additional information ‘*that I saw yesterday*’ is added to indicate specifically which man is being talked about. Non-restrictive relative clauses are illustrated by the following examples: *the man, who had arrived yesterday left this morning*. In this sentence, the speaker seems to assume that the hearer can identify which man is being talked about, and that it is one particular, identifiable ‘*man*’ that is being talked about; the relative clause serves merely to give the hearer an added piece of information about an already identified entity, but not to identify that entity.”

### 3.1.1. The Distinction between an RRC and an NRC in English

Relative clauses in English could be classified into restrictive relative clauses (RRC) and non-restrictive (appositive) relative clauses (NRC). We can see the syntactic and semantic differences between an RRC and an NRC, as illustrated in (1) and (2) (examples from McCawley (1981)).

(1) Tom has two cats which once belonged to Fred, and Sam has one. --- RRC

(2) Tom has two violins, which once belonged to Fred, and Sam has one. ---NRC

The basic syntactic difference between an RRC in (1) and an NRC in (2) is marked by the fact that the NRC in (2) has an intonation break from its head nominal while the RRC in (1) does not. The semantic contrast between them is that (1) implies that Sam's cat once belonged to Fred, whereas (2) does not imply that Sam's violin once belonged to Fred.

Another pair of examples can assure us of the difference between RRCs and NRCs.

(3) John read any book which Mary bought. --- RRC

(4) John loved Mary, who is my sister. ---NRC

The syntactic difference between an RRC in (3) and an NRC in (4) is the same as (1) and (2): the NRC in (4) is marked by an intonation break while the RRC in (3) is not. From the semantic viewpoint, the reference set for Mary in (4) is totally independent

of the appositive relative clause while the reference set for any book in (3) is necessarily dependent on the restrictive clause.

With regard to ‘restrictiveness,’ the following example in (5) shows a clear semantic difference as well as a syntactic difference indicated by the presence or absence of an intonation break (examples from Bowers (1974)):

- (5) a. The Chinese who are industrious dominate the economy.  
b. The Chinese, who are industrious, dominate the economy.

The relative clause in (5a) is an RRC while that in (5b) an NRC. According to Bowers (1974), the sentence in (5a) states that there is a subclass of the class of Chinese, namely just those who are industrious, which dominates the economy while the second sentence in (5b) expresses that the Chinese dominate the economy and the relative clause adds the information that the Chinese are an industrious people. The reference set for the head nominal the Chinese in (5a) is restricted by its modifying relative clause who are industrious. The reference set for the Chinese in (5a) is ‘the industrious Chinese’ which contrasts with for instance ‘the lazy Chinese’ or whatever. The reference set of the Chinese in (5b) is determined and fixed regardless of its RC. The Chinese in (5b) indicates ‘all of the Chinese people’. The modifying RC is just an added piece of information about the identified reference set for the Chinese in (5b).

In short, from the semantic viewpoint, the RRC and the NRC exhibit a clear contrast in interpretation: that is, the RRC participates in determining the reference set of its head nominal while the NRC does not play any role in fixing the referent of the head nominal.

From the viewpoint of word order, English does not exhibit any difference<sup>1</sup> between an RRC and an NRC. However, in accordance with the concept that different interpretations have corresponding different LF structures, Kayne<sup>2</sup> (1994) recently proposed that even though the RRC and the NRC in English have the same word order, the NRC moves to the pre-determiner position in LF to receive a proper interpretation while the RRC remains in situ. In this analysis we can see a clear contrast in structural representation at LF between the RRC and the NRC in English. In other words, the NRC in English-type languages moves out of the scope of the determiner to receive a proper interpretation in LF. In this thesis, I follow Kayne's (1994) argument that the NRC should move out of the scope of the determiner in LF while the RRC should remain in situ following the determiner. Then we can have a clear contrast between an RRC and NRC at least in LF in terms of word order.

In Kayne's (1994) analysis, the clear contrast in LF structure between the RRC and the NRC can hold of English type-languages only (Noun- or Head-initial

---

<sup>1</sup> But some authors try to establish a contrast in structural representation between the RRC and the NRC. NRCs are assumed to be separated from the head NP that they modify whereas RRC are a part of the nominal constituent containing the determiner, the head NP and the relative clause. In McCawley (1981), the RRC can have a [Det + Noun +RC] constituent structure but the NRC cannot. Ross (1967) also proposes a similar view that NRCs may be a separate clause from the matrix clause and that transformations give them the status of parentheticals; the NRC is in any event higher in the tree than the RRC.

<sup>2</sup> I will return to Kayne's analysis of the movement of NRCs in Subsection 3.3.2.

languages) but not of Japanese-type languages<sup>3</sup> (Noun- or Head-final languages). In fact, Kayne (1994) suggests that head-final languages like Japanese (and Korean) do not have the syntactic or semantic difference between an RRC and an NRC but have just one type of RC, and therefore do not show any contrast in word order between them. But in the following Subsection I show that there exists a clear contrast between an RRC and an NRC in Korean and Japanese.

### 3.1.2. The Distinction between an RRC and an NRC in Korean

The Korean equivalents of (5) exhibit the same contrast in interpretation between the RRC in (6a) and the NRC in (6b)<sup>4</sup>, as do the English counterparts in (5).

- /
- (6) a. [Ku [<sub>RC</sub> pusirehha-n] chwungkwukintul-i] kyengce-lul cipayhan-ta.  
the industrious-AM Chinese-Nom economy-Acc dominate-Dec  
‘The Chinese who are industrious dominate the economy.’
- /
- b. [[<sub>RC</sub> pusirehha-n] ku chwungkwukintul-i] kyengce-lul cipayhan-ta.  
industrious-AM the Chinese-Nom economy-Acc dominate-Dec  
‘The Chinese, who are industrious, dominate the economy.’

The difference between English and Korean is that the English examples in (5) do not show any difference in word order in overt syntax between an RRC and an NRC while the Korean equivalents in (6) show a clear syntactic difference in word order between

---

<sup>3</sup> See 3.3.2.2 for a discussion of N-final relative clauses, or Kayne (1994).

<sup>4</sup> Notice where the FOCAL stress falls. Throughout the thesis, I argue that the RRC can receive a FOCAL stress while the NRC cannot.

the RRC and the NRC: the RRC has the word order [Det + RC + Noun] and the NRC [RC + Det + Noun].

Let us consider another example showing the contrast in word order as well as interpretation between an RRC and an NRC in Korean.

- (7) a. Peter-nun [DP [D<sup>0</sup> ku] [RC ton-i manh-un] [NP yeca-lul]] cohahan-ta.  
 Topic the money-Nom many-AM woman-Acc like-Dec  
 ‘Peter likes the woman who has a lot of money.’
- b. Peter-nun [DP [RC ton-i manh-un] [D<sup>0</sup> ku] [NP yeca-lul]] cohahan-ta.  
 Topic money-Nom many-AM the woman-Acc like-Dec  
 ‘Peter likes the woman, who has a lot of money.’

As we can see, the above examples in (6) and (7) give us a clear contrast in interpretation and word order between an RRC and an NRC. (7a) is interpreted as an RRC and (7b) as an NRC. The reference set of the woman in (7a) is restricted and delimited by its modifying RC while that in (7b) is fixed and determined regardless of its modifying RC. In (7a) the speaker implies that the woman of whom he is speaking refers to ‘the woman who has a lot of money’ but not ‘the woman who does not have a lot of money’ or whatever. On the other hand, in (7b) the speaker assumes that the hearer identifies the woman, and the speaker just adds a piece of information ‘the woman has a lot of money’. Japanese RCs also show a clear syntactic and semantic difference between an RRC and an NRC, as illustrated in (8) below.

- (8) a. Ano [watashi-ga katta ] hon  
 that I-Nom bought book  
 ‘that book I bought’

- /
- b. [Watashi-ga katta] ano hon  
 I-Nom bought that book

(8a) is interpreted as an RRC and (8b) as an NRC. The referent of book in (8a) is restricted by its RC and that in (8b) is not influenced by its modifying RC, just like in Korean.

Let us consider another example showing the contrast between the RRC and the NRC in Korean. The RC in (9a) appears between the determiner and the relative head nominal while the RC in (9b) occurs preceding the determiner, just like in (6) and (7). Interpretively, the RC in (9a) is an RRC; the RC in (9b) is an NRC. The position of RRCs is different from that of NRCs.

- /
- (9) a. Ku [RC nay-ka tosekwan-eyse massna-n] yeca  
 the I-Nom library-Loc met-AM woman  
 ‘the woman whom I met at the library’

- /
- b. [RC nay-ka tosekwan-eyse massna-n] ku yeca  
 I-Nom library-Loc met-AM the woman  
 ‘the woman, whom I met at the library’

Korean or Japanese RCs occur in different syntactic positions according to restrictiveness. The word order ([Det +RC+ Noun]) of the RRCs in (6a), (7a), (8a), and (9a), contrasts with that ([RC + Det + Noun]) of the NRCs in (6b), (7b), (8b), and (9b). I claim that in Korean the NRC modifies only nominals but not some other phrases such as PPs, VPs, and CPs. In a sentence with English words substituted for Korean ones like ‘[RC John-Nom the book-ACC bought-AM] \*(kes-Nom) Mary-Acc angered’ (Lit. ‘John bought the book, which angered Mary’), if the nominal ‘kes’ (which literally means ‘thing’) does not appear after the RC, the sentence is ungrammatical unlike its English counterpart.

Another point to note concerning restrictiveness in relative clauses is that RRCs receive a FOCAL stress while NRCs do not, as seen in (6)-(9) above. This implies that RRCs have a close relationship with FOCAL Stress but NRCs do not.

Contra Kayne (1994), who argues that Japanese-type languages (including Korean) do not exhibit a clear difference between an RRC and an NRC but have only one type of RC, the examples in (6)-(9) support our claim that there exists a clear contrast in order word and interpretation between an RRC and an NRC in Korean and Japanese.

To sum up, syntactically in Korean, the RRC follows the determiner and precedes its head noun while the NRC precedes both the determiner and its head noun. Secondly, from a semantic viewpoint, the RRC and the NRC exhibit a clear contrast in interpretation: that is, the RRC participates in determining the reference set of its head nominal while the NRC does not play any role in fixing the referent of the head nominal. Thirdly, the focal stress falls on RRCs but not on NRCs.

### 3.1.3. The Contrast between an RA and an NA in Korean

In this Subsection, I argue that the contrast shown between the RRC and the NRC may apply to pre-nominal adjectives<sup>5</sup> in Korean<sup>6</sup>.

---

<sup>5</sup> Korean native informants I interrogated agree that (10a) has a restrictive interpretation while (10b) has a nonrestrictive one. It is clear that yepun 'pretty' in (10b) occurs beyond the scope of the determiner ku 'the' while yepun 'pretty' in (10a) within the scope of the determiner.

<sup>6</sup> As seen in the previous Chapter, Korean RCs and pre-nominal modifying adjectives have the same word order and the same function: (i) Korean pre-nominal adjectives are represented as having the word order, [Det + Adj + Noun] or [Adj + Det + Noun], exactly like RCs, and (ii)



- /
- (10) a. Ku yeppun sonye  
           the pretty girl  
           ‘the pretty girl’
- /
- b. Yeppun ku sonye  
           pretty the girl  
           ‘the pretty girl’

The adjective in (10a) is a Restrictive Adjective (RA) and the adjective in (10b) a Non-restrictive Adjective (NA). The RA in (10a) follows the determiner and precedes its head noun while the NA in (10b) precedes both the determiner and its head nominal, just like the RC in (6)-(9). Furthermore, we can see that the RA receives a FOCAL stress but the NA does not. The same semantic contrast shown in an RC can be found with the adjective. The referent for girl in (10a) is restricted by its modifying adjective, ‘the *pretty* girl’ not ‘the *ugly* girl’ or whatever. This predicts a contrast in semantics like: “The pretty girl, not the ugly girl” should be *ku yeppun sonye!* \* *yeppun ku sonye*. In contrast, the referent for girl in (10b) is identified and fixed regardless of its modifying adjective; the hearer and the speaker both know the referent for the girl about whom they are talking. The speaker just adds a piece of information ‘pretty’.

To support the contention that there is a syntactic and semantic difference in pre-nominal modifying adjectives with respect to ‘restrictiveness’, let us consider some pre-nominal adjectives in other languages.

---

they both modify their head nominal. The only difference between RCs and adjectives in Korean is that RCs are *clausal* adnominal modifiers and pre-nominal modifying adjectives are *phrasal* adnominal modifiers.

According to Bhattacharya (p.c.), adjectives in Hindi (as shown in (11)) and Bengali (as in (12)) show the same effect as in Korean.

(11) a.                    /  
 Wo    sundə    phuul                    (Hindi)  
       that    pretty    flower

      b.                    /  
       Sundə    wo    phuul  
       pretty    that    flower

(12) a.                    /  
 Oi    ʃundor    phul                    (Bengali)  
       that    pretty    flower

      b.                    /  
       ʃundor    oi    phul  
       pretty    that    flower

Sundə in Hindi and ʃundor in Bengali might express a ‘non-restrictive’ interpretation by being placed preceding the determiner, as expected. The same effects can also hold of Japanese adjectives<sup>7</sup>.

---

<sup>7</sup> Whitman (1981) also notes that there is a semantic and syntactic distinction between a restrictive adjective and a non-restrictive adjective in Japanese.

- (i) a. [Aoi    ano    meo] omoidasu dake-demo kyuuni ai-ta-ku naru  
       blue    that    eye    remember just-even    immediatley see- want- start  
       ‘Just remembering those blue eyes, (I) immediately start wanting to see  
       (him/her).’  
       b. [Ano aoi mi-o]            taberu na.  
       That blue berry-Acc eat Neg Imp  
       ‘Don’t eat those blue berries.’

(13) a.                    /  
 Ano kireina hana  
 that pretty flower

   /  
 b. Kireina ano hana  
 pretty that flower

As already seen in (10), the pre-nominal adjectives in (11a, 12a, and 13a) will have a restrictive interpretation and receive a FOCAL stress while the adjectives in (11b, 12b, and 13b) (which appear in the pre-determiner position) will receive a non-restrictive interpretation and they lose the FOCAL stress. The syntactic difference between English and Korean, Hindi, Bengali, and Japanese adjectives is that restrictiveness in English is expressed only by FOCAL stress while in Korean, Hindi, Bengali and Japanese, it is expressed by different positions of adjectives as well.

To sum up, the adjective yeppun, as shown in (10a), occurs following the determiner ku, restricting the reference set of the noun it modifies while yeppun in (10b) has scope over the determiner ku (note that the adjective precedes the determiner), giving a non-restrictive interpretation, as expected. The Korean adjectives express their scopal differences overtly by being placed in different positions: in the ‘restrictive’ case, the adjective occurs below the determiner while in the non-restrictive case it is placed in the position preceding the determiner. From the examples (10)-(13)

---

According to Whitman (1981), the adjective in (ia) is non-restrictive since this adjective does not play any role in identifying the NP referent; in contrast, the adjective in (ib) is restrictive since the adjective participates in identifying the NP referent. The hearer does not seem to know which berries the speaker is talking about; therefore the speaker delimits the berries by adding the adjective aoi ‘blue’.

it can be said that the restrictive adnominal adjectives have a contrastive FOCUS ( Focal stress) while the non-restrictive adnominal adjectives do not (that is, they are de-focused or de-stressed).

Now I can argue that the pre-nominal adjective in Korean has the same syntactic and semantic contrast in restrictiveness as the RC.

### 3.1.4. The Contrast between an RA and an NA in English

We may apply the logic of restrictiveness of relative clauses to English adjectives as well as to Korean adjectives, and argue that pre-nominal modifying adjectives in English are interpreted differently just as in the case of relative constructions, depending on whether the adjective restricts its head or not. This restrictiveness can be expressed by stress.

(14) The / industrious / Chinese -----> restrictive interpretation is necessary

(15) The / industrious / Chinese -----> non-restrictive interpretation is possible

According to Bowers (1974), unstressed pre-nominal adjectives and non-restrictive relative clauses have the same interpretation. By contrast, a stressed pre-nominal adjective restricts the reference set of the noun which it modifies, just as a restrictive relative clause does.

The difference between an RA and an NA in English can be expressed by where the stress falls. Let us have a look at another example.

(16) a. The / pretty / flower, not the / ugly / flower

The stress in (16) signals a kind of contrastive FOCUS. This FOCUS is active only in the case of restrictive adjectives or relative clauses. In other words, only restrictive modifiers can receive stress signalling contrastive FOCUS, and play a role in restricting the reference of their head noun. Imagine that there are many flowers in a basket; ‘the *ugly* flower’, ‘the *pretty* flower’, ‘the *rotten* flower’, etc. The restrictive adjective pretty or ugly plays a decisive role in determining its referent. The adjective restricting its referent receives the FOCAL stress while the non-restrictive adjective does not, as illustrated in (14)-(15) (see also (10-13)). This entails that the FOCUS feature (FOCAL stress) in adnominal modifiers has a close relationship with restrictiveness.

For the sake of convenience, we call both RRCs and RAs Restrictive Adnominal Modifiers (RAM), NRCs and NAs Non-restrictive Adnominal Modifiers (NAM).

### **3.2. The Movement of the NAM to the Pre-Determiner Position**

In the preceding Section, we observed that the NRC and NA (or the NAM) in Korean appears in the pre-determiner position in overt syntax but the NRC and NA (the NAM) in English occurs following the determiner. However, Kayne<sup>8</sup> (1994) claims that the NRC in English moves to the pre-determiner position in LF.

Based on the observations so far and Kayne’s analysis of the movement of English NRCs in LF, I propose that the NAM in Korean has the same underlying position as the RAM, but raises syntactically to the pre-determiner position, resulting in the word

---

<sup>8</sup> Kayne (1994) does not include the NA in the LF-movement of the NAM.

order [NAM + Det + Noun]; on the other hand, the NAM in English has the same underlying word order as the RAM, but it LF-moves to the pre-determiner position.

Under this analysis the non-restrictive interpretation for English adjectives is also obtained by moving non-restrictive adjectives to the pre-determiner position in LF, exactly as for English RCs. Korean and English pre-nominal adjectives then have the same LF structure even though they differ in overt syntax. If so, (15) will have the LF structure in (17). In contrast, a restrictive adjective industrious in (14) remains in situ.

(17)  $industrious_i [D^0 \text{ the } t_i [_{NP} \text{ Chinese}]]$

To sum up, the Korean adjectives and RCs express their semantic differences overtly by being placed in different positions: RAs and RRCs occur below the determiner and precede their head noun while NAs and NRCs are placed in the position preceding the determiner. On the other hand, English exhibits a contrast in position between the RAM and NAM in LF. Another point to remember is that the FOCAL stress falls on the RAM.

### 3.3. The Structure of Relative Clauses

#### 3.3.1. Previous Analyses

In the Principles and Parameters framework (Chomsky and Lasnik 1993), given the standard version of X-bar theory (Chomsky 1986a,b), adjunction is used to account for the structure of modifiers, which are freely iterated. Phrasal modifiers like adjectives and clausal modifiers like relative clauses are assumed to be adjoined to the category that they modify. The adjunct analysis allows multiple adjunction of the modifiers to the constituent that they modify. In a (Head-initial) language like English

or Italian where relative clauses linearly follow the nominal constituent they modify, the standard adjunct analysis makes use of the configuration of rightward adjunction. On the other hand, in (Head-final) languages like Korean and Japanese where relative clauses precede the nominal element that they modify, leftward adjunction is used.

(18) a. In the case of N-initial languages

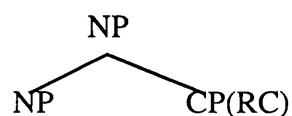

b. In the case of N-final languages

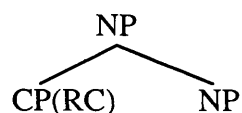

The structures in (18) of course do not show the difference between the RRC and the NRC.

Furthermore, Stockwell, Schachter and Partee (1973) and Partee (1975) distinguish between the RRC and NRC, and argue that in the case of the RRC the noun and relative clause make up a constituent and thus the RRC is a sister of N, as shown in (19); in the case of the NRC, the head noun and the determiner make up a constituent and the NRC is adjoined to NP, as illustrated in (20) (S is changed to CP for our purposes):

(19)

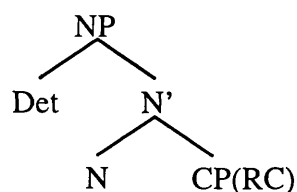

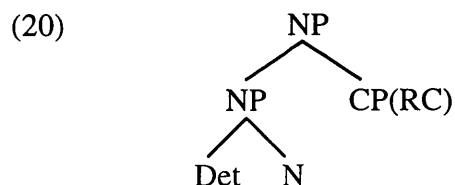

Based on the DP-hypothesis, Manzini (1994b) advances a similar idea. RRCs are taken to be right-adjoined to the head NP as given in (21a) while NRCs are right-adjoined to DP instead as in (21b). This analysis has the advantage of explaining the difference in interpretation between RRCs and NRCs without LF movement of NRCs. In the case of RRCs both NP and CP occur below the scope of the D head. In the case of NRCs the relative CP may appear above the scope of the D head, as desired.

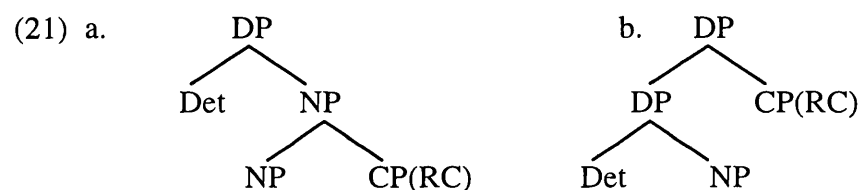

The above three adjunction analyses assume that the head noun and relative clause CP are base-generated separately.

The traditional adjunction analyses of the structure of the modifiers is, however, challenged by Cinque (1993, 1995), who argues that the free iteration of the modifiers is actually limited and constrained by some rigid ordering principles. He claims that different types of adjective occupy different positions. Based on the following examples in (22), Bianchi (1995) suggests that the thematic adjective Italiano is obligatorily postnominal whereas the adjective mera is pre-nominal.

- (22) a. L'invasione Italiana dell'Albania  
the Italian invasion of Albania



- b. \* L'italiana invasione dell'Albania
- c. Gianni ha fatto una mera proposta  
Gianni made a mere proposal
- d. \* Gianni ha fatto una proposta mera

Accordingly, instead of multiple adjunction of modifiers to one category, Cinque (1993, 1995) proposes that only one modifier can occur to the left of every head position. In other words, each modifier appears in a different position.

Another long-standing criticism alternative to the adjunction analyses of the structure of RCs can be found in Brame (1976) which argues for a raising analysis<sup>9</sup> in which the head noun of the RRC originates inside the relative clause and raises to its surface position. His motivation can be found in the possibility of relative clause constructions where part of an idiom occurs as the head noun and the rest of the idiom appears inside the relative clause. In this analysis the head noun is base-generated as a piece of the idiom inside the relative clause and raises into its surface position by a transformation, as illustrated in (23) (example from McCawley (1981)).

(23) The [ *aspersions*]<sub>i</sub> [that Bill cast [*e*]<sub>i</sub> on my character]] are unfounded.

Brame (1976) argues that the raising analysis applies to all restrictive relative clauses. This analysis gains a piece of support from the following example (from McCawley (1981)).

---

<sup>9</sup> This line of argumentation is put forward by Schachter (1973), Vergnaud (1975) and Carlson (1977).

(24) The picture of himself that John found hanging in the Post Office irritated Mary.

The structural relationship between a reflexive himself and its antecedent John is possible only when the picture of himself is reconstructed<sup>10</sup> inside the relative clause.

The LF structure for (24) which is reconstructed will then be (25) below.

(25)  $X_i$  that John found [the picture of himself]<sub>i</sub> hanging in the Post Office irritated Mary.

In (25) which reconstructs (puts back) the picture of himself, himself can properly be bound by John excluding the possibility of its being bound by Mary.

The line of argument against adjunction analyses gains some support from Larson (1988) who tries to explain an asymmetry in double object constructions. According to him, the possibility of multiple branching under  $X'$  is excluded and the leftmost goal argument appears to asymmetrically c-command the theme argument. This analysis is made possible by assuming the VP shell representation of multiple complements, as seen in 1.2.4. Since the standard formulation of X-bar theory (in the sense of Chomsky (1986a,b)), which allows right-adjunction, does not provide this kind of asymmetric structure, many authors propose to revise the standard X-bar theory.

Of course the Larson's (1988) analysis of double object verbs is controversial. In particular, it is criticised by Williams (1994). However, in this thesis, I will follow the idea of Larson (1988) concerning the structure of double object verbs.

---

<sup>10</sup> See 1.2.2.2 for discussion of reconstruction.

### 3.3.2. Kayne's (1994) Analysis

Fukui & Speas (1986), Larson (1988), Hoekstra (1992), Haider (1993), Kayne (1994), etc. are among the authors who try to constrain and revise the standard X-bar theory of the Principles and Parameters framework.

Kayne (1994) takes an important step towards the goal of restricting phrase structures. Specifically, he proposes the Linear Correspondence Axiom<sup>11</sup> (LCA) stating that linear ordering of terminal elements corresponds to asymmetric c-command; any phrase marker that violates this LCA condition is barred. From the LCA, it follows that there is a universal Spec-Head-Complement (SVO) ordering, and that specifiers are in fact left-adjoined. The only X-bar structure which is consistent with the LCA is a one-level binary branching structure allowing the left-adjunction of at most one constituent.

The LCA excludes a traditional right-adjoined configuration for postnominal relative clauses. Kayne (1994) proposes that the relative clause must be generated in a complement position by saying that since relative clauses are not theta-marked, relatives cannot be complements to a lexical head; the only plausible candidate is a functional head, as we shall see below.

#### 3.3.2.1. The [ $D^0$ CP] Structure

A question arises: why is (26b) grammatical even though it contains the ungrammatical phrase the pictures of John's in (26a) ?

(26) a. \* I found the pictures of John's.

---

<sup>11</sup> See 1.2.10.1 or Kayne's (1994) Antisymmetry (pp. 3-12) for the detailed notion of the LCA

b. I found the pictures of John's that you lent me.

Kayne (1994) proposes that in (26b) the and pictures of John's are not a constituent; instead, pictures of John's that you lent me is a constituent distinct from the. In other words, the has pictures of John's that you lent me as its complement.

Now we can ask ourselves what the structure of the pictures of John's that you lent me in (26b) is. Kayne (1994) answers in this way: the determiner the has a CP as its complement. Relative clauses in English like (26b) have the structure [D<sup>0</sup> CP].

(27) [D the [CP [DP pictures of John's]<sub>i</sub> [CP [C that [IP you lent me [e]<sub>i</sub> ]]]]]

The phrase pictures of John's in (27) moves out of the object position of the verb lent and raises into the specifier position of CP.

According to Kayne (1994), the relative clause is c-commanded by the determiner D<sup>0</sup> and linearly follows it, as shown in (28) below; the determiner has the relative clause as its complement.

(28) [DP D<sup>0</sup> CP]

Kayne (1994) offers examples of the type in (29) as a piece of independent evidence (cf. Vergnaud, 1975). It appears that in certain structures a determiner is licensed by an RRC:

(29) a. the Paris that I love / \* the Paris

b. the three books of John's \* (that I read) (cf. (26))

### 3.3.2.1.1. Relative Pronouns as Determiners

With respect to the linking relationship between the relative clause and the nominal 'head', Chomsky (1981, 1982) proposes that the relative clause is interpreted as predicated of the 'head', and the relative pronoun such as 'who' or 'which' is coindexed with the 'head' by the rule of predication. As for the nature of relative pronouns, he argues that they are conceived as operators binding the relative trace, and are supposed to occur in the specifier position of CP.

In contrast, Kayne (1994) argues that the 'head' noun is raised from its original position within the relative clause to the [Spec,CP] position. However, this raising analysis raises a question when relative pronouns appear; the head noun of the relative clause and the relative pronoun appear to compete for the same position, namely, [Spec,CP]. The Italian and French examples in (30) and (31) show that the relative head and relative pronoun cannot co-occur.

(30) \* la persona cui Bill ha visto

the person who Bill has seen

(31) \* la personne qui Bill a vue

Italian cui and French qui cannot appear as direct object relative pronouns, but they can do if they are preceded by a preposition, as illustrated in (32) and (33).

(32) la persona con cui Bill ha parlato  
the person with whom Bill has spoken

(33) la personne avec qui Bill a parlé.

The ungrammaticality of the Italian and French sentences in (30) and (31) is accounted for like this: if cui and qui appear in [Spec,CP], persona and personne cannot occur in Spec,CP. However, persona or personne can occur in [Spec,CP] as in (32) and (33) if a preposition precedes it. The occurrence of the preposition enables persona or personne to occur in the specifier position of the preposition.

(34) la [C [IP Bill a parlé avec qui personne]]

First, PP avec qui personne moves to [Spec, CP], as in (35).

(35) la [CPavec qui personne [C<sup>0</sup> [IP Bill a parlé ...]]]

personne moves to [Spec,PP], resulting in (36)<sup>12</sup>.

(36) la [CP [PP personne<sub>i</sub> [P<sup>0</sup> avec qui [e]<sub>i</sub>]] [C [IP Bill a parlé...]]]

---

<sup>12</sup> Brody (p.c.) suggests that it is much better for avec qui and *IP (Bill a parlé ...)* to form a constituent rather than personne and avec qui, which means that personne must furthermore raise out of the PP and adjoin to CP again: la [CP personne<sub>i</sub> [CP [PP t'<sub>i</sub> [PP avec qui t<sub>i</sub> ] ] [C [IP Bill a parlé ... ]]]. This analysis can apply to (39) also.

The same analysis can be extended to the Italian examples. The contrast found in (30)-(33) can be accounted for in terms of the availability of a landing position for the NPs persona and persone. When the constituent having a preposition is moved to [Spec,CP], the head NP only can again raise to the specifier position of the preposition like (36). When no preposition is available, the head NP has no place to move. The simultaneous movement of the relative pronoun and the head noun into [Spec,CP] results in an ungrammatical derivation, as seen in (30) and (31). The following English example has the same process, as in (34)-(36).

(37) the [C [IP he broke it [PP with which hammer]]]

The whole PP moves to [Spec,CP], yielding the structure (38).

(38) the [CP [with which hammer]<sub>i</sub> [C [IP he broke it [e]<sub>i</sub> ]]]

Kayne (1994) proposes that relative pronouns are base-generated as determiners of the head noun, and move to [Spec,CP] with their head noun; however, they are split off from their head NP when the NP hammer raises to [Spec,PP] (probably via [Spec,which]).

(39) the [CP [PP [hammer]<sub>i</sub> [P with [DP [e]<sub>i</sub> [D which [e]<sub>i</sub>]]]]] [C [IP ...



In contrast, structures which do not have a preposition as in (40) are possible in English. Notice that the corresponding structures in Italian and French are not possible (look at (30) and (31)).

- (40) a. the picture which Bill saw  
b. the person who Bill saw

The contrast between English (40) and Italian and French ((30) and (31)) can be accounted for in this way: English uses the specifier position of the *wh*-determiner as a landing site for the head nominal. That is, (41) becomes (42). Probably Italian and French seem to be unable to exploit the [Spec,*WhP*] position as a landing site for movement of the head nominal.

(41) the [<sub>CP</sub> which picture [ c [<sub>IP</sub>...

(42) the [<sub>CP</sub> [<sub>WhP</sub> picture<sub>i</sub> [<sub>wh</sub> which [e]<sub>i</sub> ] ] [c [<sub>IP</sub> ....

According to Kayne (1994), 'who' or 'which' is not an independent pronoun any more, but a determiner of the relative head noun. In other words, a relative pronoun is a subconstituent of the relative head noun. As seen in (42), the relative pronoun, which, together with its head noun, picture, moves into [Spec,CP] and then only the head noun (picture) further moves into the specifier position of *WhP* leaving the relative pronoun behind.



### 3.3.2.2. N-Final Relative Clauses

In N-final languages the relative clause precedes the head noun which it modifies. Kayne (1994) claims that given the LCA, N-final relative clauses must also have the same [ $D^0$  CP] structure that N-initial relatives have. Based on the evidence found in Amharic, Kayne (1994) proposes that the relative clause in N-final languages moves into [Spec,DP]. However, if the relative clause CP moves to [Spec,DP], then the head noun cannot follow the relative clause. Remember that the head noun of the relatives occurs in [Spec,CP]. Therefore, for the relative clause to precede the relative head noun in N-final languages, the relative clause that moves to [Spec,DP] should be IP and not the whole CP, as in (43).

(43) [<sub>DP</sub> IP<sub>j</sub> [<sub>D</sub> the [<sub>CP</sub> picture [<sub>C</sub> [e]<sub>j</sub> ]]]]

Here the NP picture which has moved to [Spec,CP], can be preceded by the determiner as well as the relative clause IP which moved to [Spec,DP]. For the N-final relative languages IP moves to [Spec,DP]. Kayne (1994) assumes that the relative clause is the IP that has been raised to [Spec,DP], and that the head NP is left behind in [Spec,CP] following the determiner.

### 3.3.2.3. Structural Difference between RRCs and NRCs

Some authors propose that RRCs in English-type languages are right-adjoined to the head noun and c-commanded by its determiner. In contrast, NRCs (Appositive Relative Clauses) are assumed to be right-adjoined to a category that appears above the determiner. Fabb (1990) argues that RRCs are adjoined to N-bar (inside N''), and

NRCs to NP (outside N’), where a determiner occurs in [Spec,NP]. According to Fabb (1990) and Kayne (1994), a non-restrictive interpretation of a relative clause cannot be possible when the relative clause appears in the scope of the determiner. This implies that the non-restrictive RC has a different LF structure from the restrictive RC from the interpretive viewpoint.

However, Kayne (1994) notes that some syntactic differences between RRCs and NRCs do not justify the assumption of two completely unrelated structures. Kayne (1994) furthermore shows that there is no need for construction-specific structures which distinguish between RRCs and NRCs, and argues that in Japanese-type languages, the restrictive and non-restrictive interpretations are not formally distinguished in the overt syntax<sup>13</sup>. Thus Kayne (1994) assumes that NRCs have the same base structure as RRCs, and that the non-restrictive interpretation results from the leftward movement of the relative clause IP to [Spec,DP]. In this analysis, then, there is supposed to be no syntactic difference between RRCs and NRCs in N-final languages because in those languages all RCs (irrespective of whether they are RRCs or NRCs) have just the one structure [RC + (Det) + Noun], and must appear in the [Spec,DP] position.

#### **3.3.2.4. The Structure of NRCs**

According to Kayne (1994), both RRCs and NRCs have the same structure [<sub>DP</sub> Det [<sub>CP</sub> NP<sub>i</sub> [<sub>C</sub> IP ... [e]<sub>i</sub> ... ]]], where NP has moved into [Spec,CP] from within IP.

---

<sup>13</sup> Contrary to Kayne (1994), in Subsection 3.1.2, I showed that there is a clear syntactic difference between RRCs and NRCs in N-final languages.

English RRCs and NRCs have the same structure in the overt syntax; however, only NRCs moves to [Spec,DP] in LF, leaving its head nominal behind in [Spec,CP], as in (44).

(44)  $[_{DP} IP_i [_D [_{CP} NP [C' C [e]_i ]]]]$

After the LF movement, the non-restrictive relative IP is no longer within the scope of  $D^0$ . Kayne (1994) suggests that this LF movement is due to a syntactic feature which is activated by the intonation break. The syntactic feature is deleted after the movement of the relative clause IP. In an N-initial language like English, that deletion is done in LF while in N-final languages like Korean or Japanese the deletion takes place in overt syntax. This overt deletion operation in N-final languages requires all the relative clauses to move to [Spec,DP] overtly (irrespective of whether they are RRCs or NRCs). They must all overtly appear in [Spec,DP] in the Kayne's  $[D^0 CP]$  structure.

### 3.3.3. Some Problems with Kayne's $[D^0 CP]$ Structure

The following Korean relative examples pose a problem for Kayne's (1994)  $[D^0 CP]$  structure<sup>14</sup> which cannot express any syntactic and semantic difference between RRCs and NRCs in N-final languages. As seen in 3.1.2, Korean RCs show that there is a syntactic difference in word order between an RRC and an NRC.

---

<sup>14</sup> Some authors are opposed to Kayne's (1994)  $[D^0 CP]$  analysis. See Borsley (1996) for Polish and Manzini (1994b) for Italian.

- (45) a. [<sub>DP</sub> [<sub>D</sub><sup>0</sup> Ku] [<sub>RC</sub> Nay-ka miwohay-ss-ten] [<sub>NP</sub> yeca]] ---- RRC  
           the     I-Nom hate-Pst-AM        woman  
           ‘the woman whom I hated’
- b. [<sub>DP</sub> [<sub>RC</sub> nay-ka miwohay-ss-ten] [<sub>D</sub><sup>0</sup> ku] [<sub>NP</sub> yeca]] ----- NRC  
           I-Nom hate-Pst-AM                the     woman  
           ‘the woman, whom I hated’
- (46) a. [<sub>DP</sub> [<sub>D</sub><sup>0</sup> ku] [<sub>RC</sub> ton-(i) manh-un]                [<sub>NP</sub> kwapwu]] ----- RRC  
           the     money-(Nom) be many-AM     widow  
           ‘the widow who has a lot of money’
- b. [<sub>DP</sub> [<sub>RC</sub> ton-(i) manh-un ]                [<sub>D</sub><sup>0</sup> ku ] [<sub>NP</sub> kwapwu]] ----- NRC  
           money-(Nom) be many-AM     the     widow  
           ‘the widow, who has a lot of money’

In (45a) and (46a) the RCs clearly intervene between the determiner and the head noun, unlike in Kayne’s (1994) analysis. These RCs in (45a) and (46a) above cannot be accommodated in Kayne’s [<sub>D</sub><sup>0</sup> CP] structure. The RCs in (45b) and (46b) can appear in [Spec,DP], as expected.

### 3.3.4. The Structure of RCs in an N-Final Language

In Subsection 2.3.3, I proposed that the RCs in a N-final language like Korean, are base-generated in the specifier position of AgrP occurring between DP and NP, and that the non-restrictive relative clauses only move to the pre-determiner position, or [Spec,DP], as illustrated in (47) below.

(47) a.

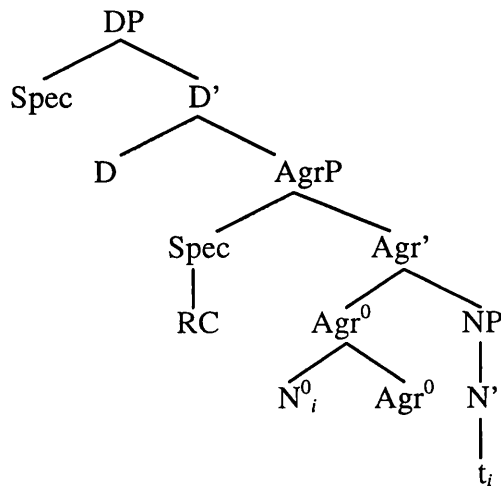

b.

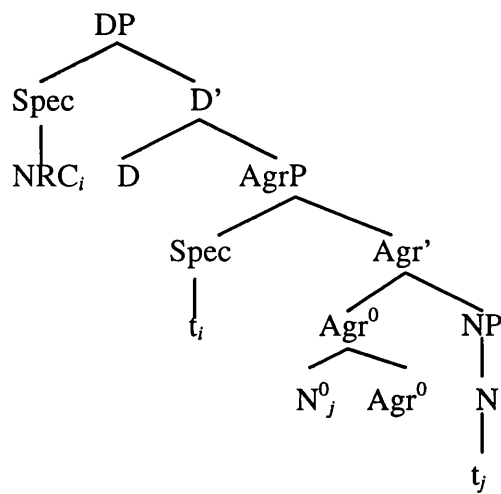

The head noun moves to Agr<sup>0</sup> to check its agreement feature with the corresponding feature of the RC in [Spec,AgrP]. This is to say that an RC is base-generated in [Spec,AgrP], regardless of whether it is an RRC or NRC, and then the RRC remains in situ while the NRC only moves to the pre-determiner position, that is, [Spec,DP].

### 3.4. Focus and Non-Focus Features in Adnominal Modifiers

In this Section, I examine the function of FOCAL Stress in adnominal modifiers, and what drives the movement of non-restrictive adnominal modifiers into the pre-determiner position.

In Sections 3.1 and 3.2 above, we noticed that the restrictive adnominal modifier (RAM) remains in situ and has FOCUS (Focal stress) while the non-restrictive adnominal modifier (NAM) does not have Focal stress, and moves out of its base-generated position, and raises to the pre-determiner position. The movement of the NAM takes place in overt syntax for Korean and in LF for English. I identify FOCAL stress with a FOCUS feature. Based on this, I claim that the [Spec,AgrP] is the FOCUS position and therefore the de-focused adnominal modifier should move out of the focus position to [Spec,DP].

Concerning the movement of non-restrictive relative clauses (NRCs) or adjectives (NAs), I propose that the NAM is assigned a NON-FOCUS feature which triggers its syntactic movement from [Spec,AgrP] to [Spec,DP]. Notice that when the adnominal modifier does not have FOCAL stress, it appears out of the scope of the determiner, as seen in (6)-(15). As seen in Section 3.3.2, Kayne (1994) claims that the non-restrictive RC should get out of the scope of the determiner. It is my argument that the restrictive modifier has a FOCUS feature and remains in [Spec,AgrP] while the non-restrictive modifier has a NON-FOCUS feature and moves to [Spec,DP].

I assume that DP and MP (or IP) have parallel properties concerning FOCUS and NON-FOCUS, as seen in 2.1. Both [Spec,DP] and [Spec,MP] are the positions where the NON-FOCUSed element can appear; in contrast, [Spec,AgrP] in the DP-structure

and [Spec,Agr<sub>S</sub>P] in the IP-structure are assumed to be FOCUS positions, as illustrated in (48).

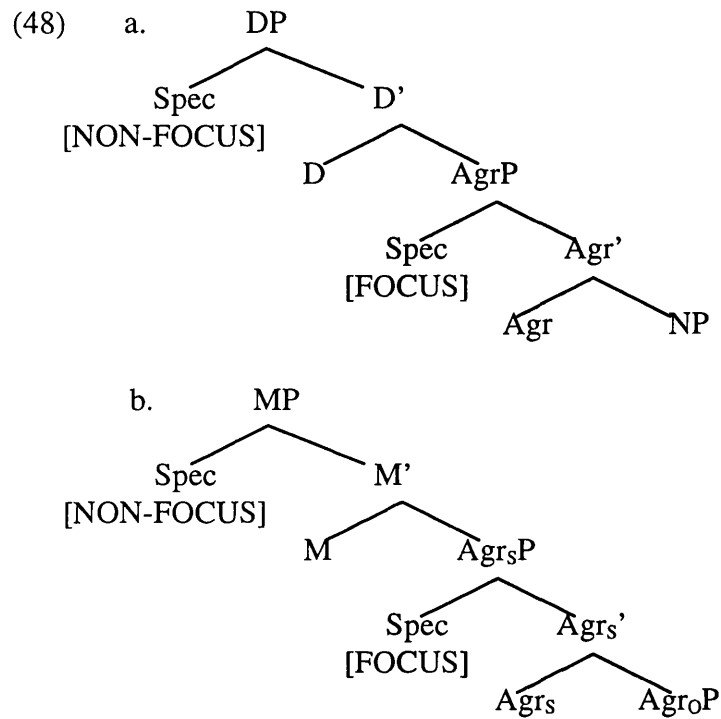

With this background in mind, let us turn to the case of Korean RCs and their syntactic structures, as illustrated in (49) and (50), respectively.

- (49) a. Ku nay-ka salangha-n yeca  
 the I-Nom love-AM woman  
 'the woman whom I loved'
- b. Nay-ka salangha-n ku yeca  
 I-Nom love-AM the woman  
 'the woman, whom I loved'

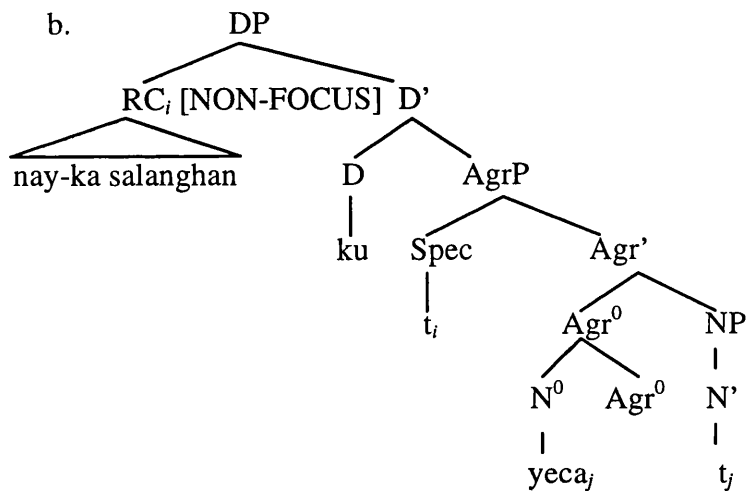
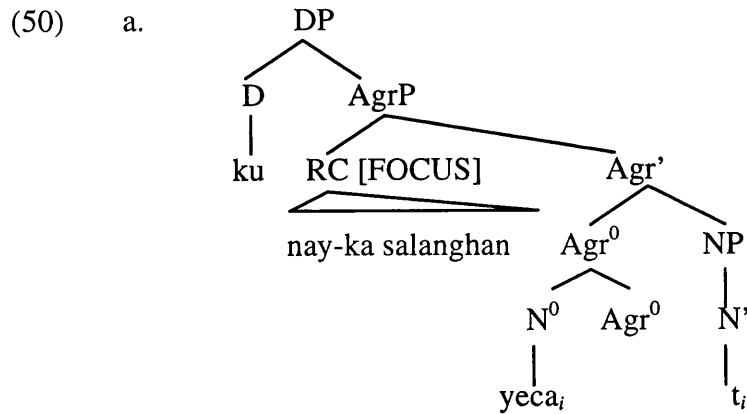

In Korean an RC is base-generated in [Spec,AgrP]. An RRC having a FOCUS feature remains in [Spec,AgrP]; an NRC having a NON-FOCUS feature moves further to [Spec,DP] to check its [NON-FOCUS]<sup>15</sup> and to receive a non-restrictive interpretation, as illustrated in (50) above.

If I am on the right track, my argument is consistent with the minimalist framework (Chomsky 1995) in which movement is characterised as having

---

<sup>15</sup> McConvell (1973) describes and analyses NRCs in Hausa as '(right-dislocated) topics' which are marked off from the rest of the sentence by a pause. The NON-FOCUS feature may equivalently be called TOPIC feature.



morphological reasons. I propose that a [NON-FOCUS] feature<sup>16</sup> is assigned to the determiner  $D^0$ , and, if assigned, then the determiner bearing this [NON-FOCUS] feature attracts an RC or pre-nominal adjective having a [NON-FOCUS] feature into [Spec,DP] to check and delete its [NON-FOCUS] feature, resulting in the movement of the whole RC or the adjective into [Spec,DP].

The argument that the restrictive modifier has a FOCUS feature and the non-restrictive one has a NON-FOCUS feature is supported by Jaggar (1997). He notes that the restrictive relative clause in Hausa, an Afroasiatic language, has only the FOCUS form of INFL while the non-restrictive relative clause has either the FOCUS or NON-FOCUS form. That is, the NON-FOCUS feature is related only to the NRCs and never to the RRCs.

Jaggar (1997)<sup>17</sup> argues that the FOCUS:NON-FOCUS behaviour is attributable to the fact that, unlike RRCs, NRCs do not uniquely restrict/define/identify their antecedents. NRCs do not restrict the reference set for the head nominal that they modify, but merely add a piece of information. With respect to the FOCUS:NON-FOCUS distinction in RCs, Jaggar (1997) says:

---

<sup>16</sup> This NON-FOCUS feature in Korean is assumed to be strong and [-Interpretable] and therefore should be checked and deleted before Spell-Out.

<sup>17</sup> Parsons (1981) was the first to recognise that there is a formal distinction between Restrictive and Non-restrictive RCs in Hausa. He proposes that one syntactic property distinguishing the two RC-types was that the NON-FOCUS form of INFL as well as the FOCUS form of INFL can be made use of in Non-restrictive RCs; in contrast, RRCs exploits only the FOCUS form of INFL.

“Since NRCs do not have the specifying power of RRCs, NRCs license a wider range of tense-aspect options. In NRCs, some speakers permit either the FOCUS form of the INFL as occurs in RRCs, or the NON-FOCUS form of the INFL as an alternative. Notice that if the RC is semantically restrictive, the INFL must take the FOCUS form, not the NON-FOCUS form. Any explanation of the distribution and increased acceptability of the NON-FOCUS INFL in NRCs must refer to semantic (and not simply formal) factors. According to Schuh (1985), the choice of the specific/presuppositional FOCUS form in narrative discourse is attributable to the semantic fact that the speaker has a specific time and /or place in mind when the actualised event took place, and also presupposes that the hearer shares this assumption. Use of the definite/specific FOCUS form acts to narrow down the temporality of the single, actualised events of the historical narrative, all of which have a clear and specific end result.”

To sum up, the FOCUS feature of RCs is closely related to the RRC and the NON-FOCUS is tied to the NRC.

### **3.5. IHRCs**

The existence of Internally Headed Relative Clauses (IHRCs) was first postulated by Wilson (1963) in the earliest transformational framework. Many scholars have since studied the structure of IHRCs in comparison with Externally Headed Relative Clauses (EHRCs). It is well known that IHRCs are found in such languages with (S)OV word order as Japanese, Korean, Tibetan, Quechua, Navajo, etc. (cf. Keenan 1985). Cole (1987) proposes the structure of IHRCs, as shown in (51a) below:

(51) The Anaphoric Head Hypothesis

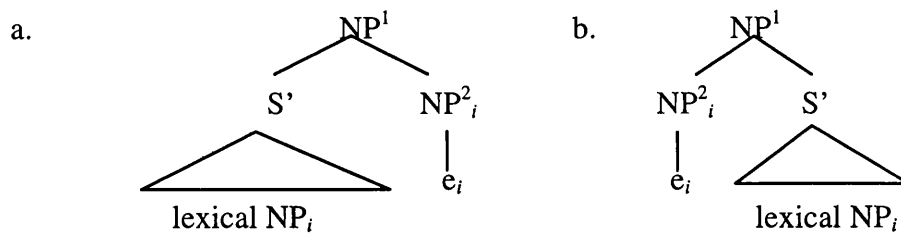

The structure in (51a) is for N-final languages and the structure in (51b) is for N-initial languages. Cole (1987) proposes that the IHRC is the sister of a phonetically null external head which is anaphoric to the internal head and that the limitation of IHRC to head-final structures i.e. to (51a) is due to the following general condition:

(52) An anaphor cannot both precede and c-command its antecedent.

According to Cole (1987), the restriction of IHRCs to languages displaying OV word order can be explained under the condition (52) if IHRCs in N-final languages have a structure like (51a). In overt syntax IHRCs have phonologically null heads which are co-indexed with a nominal inside the modifying clause, and in LF the nominal interpreted as the head is raised from the modifying clause into the NP<sup>2</sup> position in (51a). Note that (52) is obeyed in that the null anaphor [e] under the NP<sup>2</sup> position in the structure (51a) can c-command but cannot precede its lexical antecedent within the RC; by contrast the structure (51b) violates the general condition in (52) in that the null anaphor [e] in (51b) both precedes and c-commands its antecedent within the RC.

Kayne (1994) agrees with Cole (1987) that the limitation of IHRCs to languages having OV word order is due to the general condition (52).

The analysis assuming the structure (51) for IHRCs explains why IHRCs are possible in N-final languages like Korean and Japanese but not possible in N-initial languages like English and Italian. In this thesis I agree with Cole (1987) that the general condition in (52) holds for Korean IHRCs. However, as will be seen in 3.5.3, I argue that the structure for IHRCs must be (58) below but not (51a) since Cole's (1987) structure assumed in (51a) for IHRCs cannot account for the non-restrictive property of Korean IHRCs.

### 3.5.1. The Structure of IHRCs

This Subsection examines whether the structure in (47) for ordinary relative clauses (or EHRCs) can be extended to Korean IHRCs. S.-E. Jhang (1991) shows that IHRCs do exist in Korean. The IHRCs in Korean must be headed by 'kes' which literally means 'thing,' and the lexical head noun appears inside the relative clause, as exemplified in (53) (from K.-O. Lee (1991)):

- (53) a. [*Chayk* pilyeka-n] *kes* nayil kackoo-kessumnita.  
           book borrow-AM thing tomorrow bring back-Future  
           ‘(I) will bring back the book I borrowed tomorrow.’
- b. [*kwudwu* ttak-un] *kes* eti twu-ess-ni?  
           shoe shine-AM thing where put-Pst-Q  
           ‘Where did (you) put the shoes (you) polished?’
- c. [ecey os sa-n] *kes* poca.  
           yesterday clothes bought-AM thing see  
           ‘Let’s see the clothes (you) bought yesterday.’

K.-O. Lee (1991) identifies the sentences in (53) as IHRCs, where the semantic head noun (the italicised and underlined noun) is internal to the relative clause.

S.-E. Jhang (1994) presents the structure for Korean IHRCs and EHRCs in (54).

(54) a. EHRC

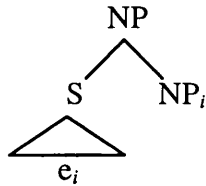

b. IHRC

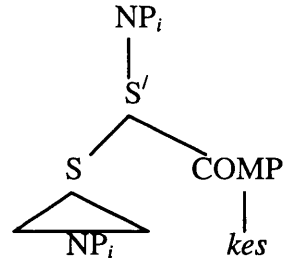

In this analysis, unlike Cole's (1987), S.-E. Jhang (1994) does not assume the existence of a null anaphoric head in Korean IHRCs, and therefore the movement of the lexical head NP is not involved. However, this analysis also cannot explain the non-restrictive property of IHRCs in Korean.

B.-S. Yang (1994) compares the structure of EHRCs with that of IHRCs, based on the sentences in (55) and (56) below.

(55) EHRCs:

- a. Chelswu-ka [ *e<sub>i</sub>* theci-n ] *swutokwan<sub>i</sub>*-lul kochi-ess-ta.  
 Nom be broken-AM water pipe-Acc fix-Pst-Dec  
 'Chelswu fixed the water pipe that was broken.'
- b. [ *e<sub>i</sub>* singsinghate-n ] *koki<sub>i</sub>*-ka ssek-ss-ta.  
 fresh-AM fish-Nom rotten-Pst-Dec  
 'The fish that was fresh was rotten.'

(56) IHRCs:

- a. Chelswu-ka [ *swutokwan* -i theci-n ] *kes*-lul kochi-ess-ta.  
 Nom water pipe-Nom be broken-AM *kes*-Acc fix-Pst-Dec  
 'Chelswu fixed the water pipe that was broken.'
- b. [ *koki*-ka singsinghate-n ] *kes*-i ssek-ess-ta.  
 fish-Nom fresh-AM *kes*-Nom rotten-Pst-Dec  
 'The fish that was fresh was rotten.'

Furthermore, unlike S.-E. Jhang (1994), B.-S. Yang (1994) argues that EHRCs and IHRCs have the same structure, schematised in (57) below. But a relative clause will simultaneously never be externally and internally headed. This generalisation is due to binding condition C of Chomsky (1981) whereby an R-expression must be free within its governing category. If an external head is lexically realised in IHRCs, the external head then comes to bind its internal referential head noun, resulting in a violation of the binding condition C.

(57) The Structure of Korean Relative Clauses (either IHRC or EHRC)

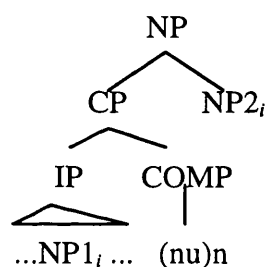

in EHRC: NP1<sub>i</sub> = gap or resumptive pronoun

NP2<sub>i</sub> = lexical head

in IHRC: NP1<sub>i</sub> = lexical head

NP2<sub>i</sub> = pro-form ('kes')

B.-S. Yang (1994) assumes that 'kes' in IHRCs is a kind of pro-form which binds the internal lexical head NP, as illustrated in (57). But this binding relation between NP1 and 'kes' in (57) violates binding condition C of Chomsky (1981); the internal lexical NP is bound by 'kes', resulting in a violation of the binding condition C. Due to this binding problem, I cannot take B.-S. Yang's structure in (57) for Korean IHRCs. However, I follow B.-S. Yang's claim that 'kes' in IHRCs is a pro-form which is equivalent to English 'one'.

Based on our analysis of Korean RCs in Section 3.3.4, I argue that the structure assumed in (47) can also be exploited for IHRCs. The structure in (47) is repeated here as (58).

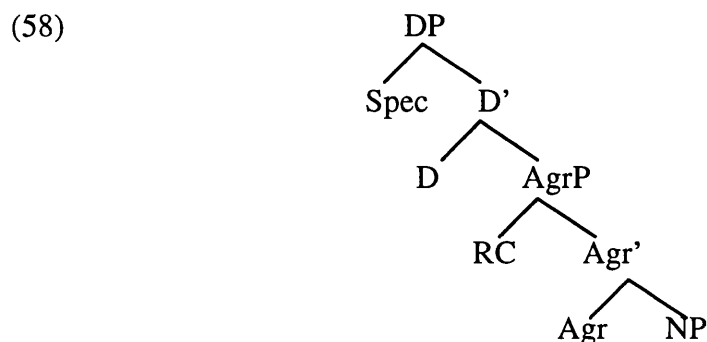

In other words, I suggest that this structure in (58) can account for IHRCs as well as ordinary relative clauses (EHRCs) in Korean.

### 3.5.2. The Position of ‘kes’ in IHRCs

It is controversial whether ‘kes’ appears in the Comp position of the RC, or in the NP position as a pro-form, or something else. According to S.-W. Lee (1983) and I.-S. Yang (1972), ‘kes’ is characterised as a complementizer. H.-J. Yoon (1991) takes the position that ‘kes’ belongs to Comp at D-structure and is raised to the head of the external NP at S-structure.

Another analysis of ‘kes’ as appearing in the Comp position can be found in Lee, Lust and Whitman (1990). Relative clauses in Korean do not take complementizers, unlike in English where relative clauses usually do, as in (59) below:

- (59) a. \* [ apa-ka      \_\_\_\_      ssun-n      kes] ankyung ---- EHRC  
           father-Nom            wear-AM      kes      glasses  
           ‘the glasses which (my) father wears’

- b. [ apa-ka      ankyung-ul ssun-n] kes-ul na-nun boa-ss-ta ---- IHRC  
 father-Nom glasses-Acc wear-AM kes-Acc I-Top see-Pst-Dec  
 'I saw my father wearing the glasses.'

In EHRCs, '*kes*' does not appear with the external head NP. Whitman (1989) explains the reason as follows: the subject in Korean is assigned nominative case by Infl which is raised into the Comp position. However, if there is '*kes*' in the Comp position, Infl cannot move to Comp. Therefore '*kes*' should not occur in the Comp position. According to Whitman (1989), this is why a complementizer does not appear in Korean relative constructions (EHRCs). If this is the case, we cannot account for the contrast between EHRCs and IHRCs with respect to the nominative case-assignment and the occurrence of '*kes*', as illustrated in (59a-b). First, we can ask why in the case of EHRCs, Infl cannot assign nominative case to the subject without raising to the Comp position, allowing '*kes*' to appear in the Comp. If the movement of Infl to Comp for nominative case-assignment is necessary, why does the movement not happen in the case of IHRCs where '*kes*' appears in the Comp position, as illustrated in (59b) ? On the other hand, if Infl can assign nominative case without moving to C, just in the case of IHRCs, it should be able to assign nominative case to the subject, allowing '*kes*' to appear in Comp, even in the case of EHRCs. Given this explanation, '*kes*' cannot be identified as a Comp.

### 3.5.2.1. '*Kes*' as a Pro-Form in IHRCs

According to B.-S. Yang (1994), '*kes*' can be used as an independent pro-form, as in (60).



- (60) a. ku kes-un            cengmalo    pissa-ta.  
           the thing-Topic really        expensive-Dec  
           ‘It is really expensive.’
- b. John-i                ce kes-ul            cohahan-ta.  
           Nom            that thing-Acc    like-Dec  
           ‘John likes that one.’
- c. Mary-nun cuwk-ess-ta.        Ku kes-i            John-ul            koirophin-ta.  
           Top be killed-Pst-Dec    the thing-Nom        Acc            bother-Dec  
           ‘Mary was killed. It (the fact) bothers John.’

B.-S. Yang (1994) also claims that IHRCs have the same clause structure as EHRCs, and that ‘kes’ occurs in the external NP position and functions as a pro-form like English ‘one,’ not as a complementizer.

- (61) a. yeki-ey [computer<sub>i</sub>-ka    kochangna-n]    kes<sub>i</sub>-i    twu-kay    iss-ta.  
           here-Loc    computer-Nom    be broken-AM    one-Nom    2-CL    be-Dec  
           ‘Here are two computers that are broken.’
- b. nay-ka [koki<sub>i</sub>-lul    cap-un ]    kes<sub>i</sub>-ulo    mawuntang-ul    kkuly-ess-ta.  
           I-Nom    fish-Acc    catch-AM    one-Inst    hot soup-Acc    cook-Pst-Dec  
           ‘I cooked the hot soup with the fish which I caught.’
- c. Mary-ka [ton<sub>i</sub>-ul            pili-n ]            kes<sub>i</sub>-ulo    chayk-ul    sa-ss-ta.  
           Nom    money-Acc    borrow-AM    one-with    book-Acc    buy-Pst-Dec  
           ‘With money Mary borrowed, she bought a book.’

Based on B.-S. Yang’s (1994) analysis of ‘kes’ as a pro-form, I propose that ‘kes’ appears in the head NP position in the structure (58). The RC (IHRC) appears in [Spec,AgrP] and ‘kes’ is base-generated in N<sup>0</sup>. This analysis does not violate the general condition (52) nor the binding condition C for IHRCs. Notice that the lexical antecedent in an RC precedes its pro-form ‘kes’. The pro-form ‘kes’ neither precedes nor c-commands its lexical antecedent in our structure (58). In addition, in our

structure (58) 'kes' appearing under N<sup>0</sup> cannot c-command and bind<sup>18</sup> its antecedent unlike in B.-S. Yang's (1994) structure (57) where 'kes' can c-command and bind its lexical antecedent. The structure for (62a) then will be (62b).

- (62) a. [DP [AGRP [RC ecey os sa-n] [AGR<sup>0</sup>] [NP kes]]] poca.  
 yesterday clothes bought-AM kes let's see  
 'Let's see the clothes (you) bought yesterday.'

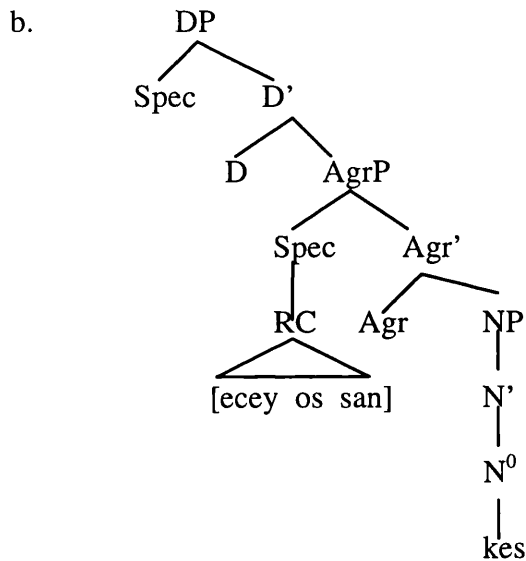

<sup>18</sup> I adopt the notion of Binding which is defined in terms of m-command (Aoun and Sportiche (1983)), as follows:

(i) Bind

$\alpha$  binds  $\beta$  iff  $\alpha$  m-commands  $\beta$  and  $\alpha, \beta$  are coindexed.

(ii) M-command

$\alpha$  m-commands  $\beta$  iff  $\alpha$  does not dominates  $\beta$  and every  $\gamma, \gamma$  a maximal projection, that dominates  $\alpha$  dominates  $\beta$ .

The whole relative clause can appear in the Spec position of AgrP, and 'kes' is base-generated in N<sup>0</sup>. In the above structure 'kes' cannot c-command and precede its lexical antecedent. Notice that in B.-S. Yang's (1994) structure in (57) 'kes' c-commands its lexical antecedent, violating the binding C condition of Chomsky (1981).

If 'kes' is taken to appear in the external N<sup>0</sup> position as a pro-form, we can explain the fact that 'kes' cannot co-occur with an external lexical head, as shown in (63). They compete with each other for the same position.

- (63) \* [ecey \_\_\_ ilk-un] kes sinmwun eti twuessni ?  
 yesterday read-AM kes newspaper where put  
 'Where did you put the newspaper that you read yesterday ?'

However, the construction will be perfectly fine if we delete either sinmwun 'newspaper' or 'kes', as illustrated in (64) and (65) below, or if it will become an IHRC, as in (66). (67) is the structure for (66).

- (64) [ecey \_\_\_ ilk-un] kes eti twu-ess-ni ?  
 yesterday read-AM kes where put-Pst-Q  
 'Where did you put the thing that you read yesterday ?'

- (65) [ecey \_\_\_ ilk-un] sinmwun eti twu-ess-ni ?  
 yesterday read-AM newspaper where put-Pst-Q  
 'Where did you put the newspaper that you read yesterday ?'

- (66) [ecey sinmwun ilk-un] kes eti twu-ess-ni ?  
 yesterday newspaper read-AM kes where put-Pst-Q  
 (Lit.) 'Where did you put the thing that you read the newspaper yesterday ?'  
 'Where did you put the newspaper that you read yesterday ?'

(67)

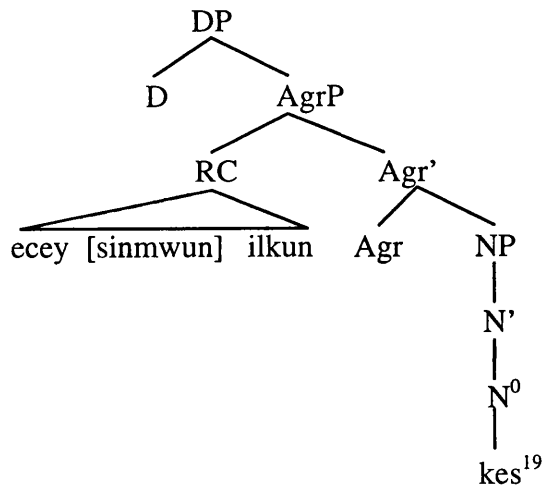

### 3.5.3. IHRCs as Non-restrictive Relative Clauses

Consider the existence of the determiner ku ‘the’ appearing between an IHRC and ‘kes’, as illustrated in (68).

- (68) a. [DP [RC ecey os sa-n] [D<sup>0</sup> **ku**] [NP kes]] poca.  
yesterday clothes bought-AM the kes let’s see  
‘Let’s see the clothes (you) bought yesterday.’

---

<sup>19</sup> I assume that the lexical head noun in EHRCs moves to the head of AgrP but ‘kes’ in IHRCs does not raise to the head of AgrP since there is feature agreement between the adnominal modifier and the lexical noun in EHRCs but not between the adnominal modifier and ‘kes’ in IHRCs.

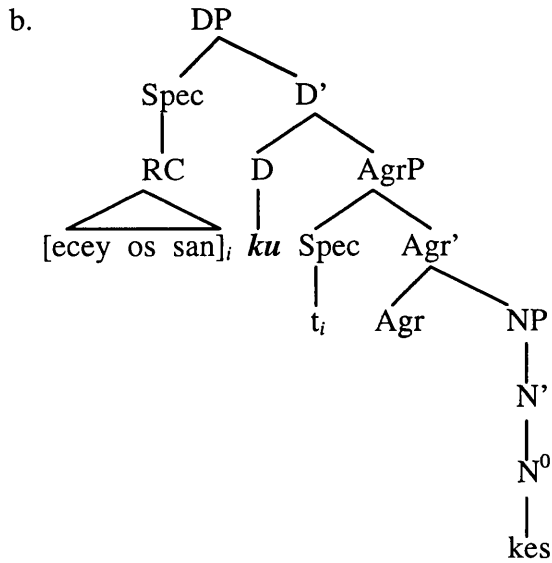

This structure implies that the above IHRC should appear in [Spec,DP], as an NRC. Consider the following ungrammatical sentence (69a) and its structure (69b). When an IHRC follows the determiner ku ‘the’, the IHRC is ungrammatical, as shown in (69) below.

(69) a. \* [DP [D<sup>0</sup> *ku*] [AGRP [RC *ecey os sa-n*] [AGR<sup>0</sup>] [NP *kes*<sub>i</sub>]]] *poca*.  
 The yesterday clothes bought-AM kes let’s see  
 ‘Let’s see the clothes (you) bought yesterday.’

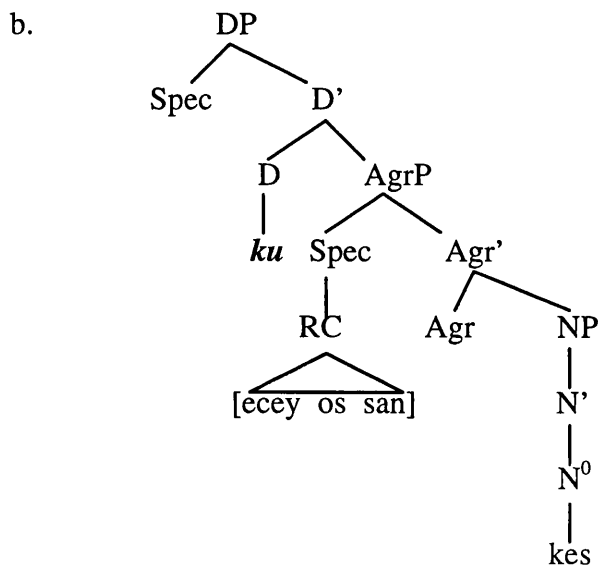

This observation suggests that IHRCs in Korean are not RRCs but NRCs and therefore should appear in [Spec,DP]. The suggestion that an IHRC is an NRC but not a RRC is supported by the fact that the determiner ku 'the' cannot precede an IHRC unlike in the case of normal EHRCs.

Dryer (1994) argues that IHRCs in Japanese look like non-restrictive relative clauses (NRCs) in English. B.-S. Yang (1994) also claims that IHRCs in Korean are non-restrictive relative clauses (NRCs). The conclusion that IHRCs are NRCs is accommodated by our structure (58). But the structures assumed in (51a), (54b) and (57) cannot tell a structural difference between an RRC and an NRC and therefore tell whether an IHRC is an RRC or an NRC.

Summarising, I argued that '*kes*' appears in the  $N^0$  position in the structure (58), not violating the binding condition C of Chomsky (1981). This analysis accounts for why '*kes*' and the external head nominal cannot co-occur. In addition, I claimed that the structure in (58) can also account for the fact that an IHRC is an NRC, and why IHRCs cannot follow the determiner ku 'the'.

## CHAPTER 4

### TOPICALIZATION

In this Chapter, I consider topicalization in Korean within the framework of feature-checking theory (Chomsky 1995).

In the old GB theory topicalization in Korean has been analysed as an instance of either movement or base-generation. According to Chomsky (1981, 1986a,b), D-structure is defined as a pure representation of theta relations: a theta-marked argument should appear in an argument position. If so, the following example should involve the movement of the argument topic to A'-position, [Spec,CP].

- (1) [CP John<sub>i</sub>-un<sup>1</sup> [IP Mary-ka t<sub>i</sub> cwuky-ess-ta]].  
          Top                  Nom      kill-Pst-Dec  
          ‘As for John<sub>i</sub>, Mary killed him<sub>i</sub>.’

The argument topic must be base-generated in an A-position. John then moves to [Spec,CP], as in (1). This analysis follows the movement analysis of topics.

Another option is to assume that topics do not involve movement at all. Let us consider the example (2).

- (2) [CP Sayngsun-un [IP coki-ka choykoi-ta]].  
          Fish-Top      redsnapper-Nom  best-Dec  
          ‘As for fish, redsnapper is best.’

---

<sup>1</sup> *un* is attached to the topic NP ending with a consonant; *nun* with a vowel.

Y.-S. Kim (1988) suggests that sayngsun ‘fish’ in (2) is not an argument: it does not have any theta relation to the predicate choykoita ‘be best’. This means that sayngsun ‘fish’ cannot be present in D-structure. If so, sayngsun ‘fish’ in (2) cannot involve movement but should be directly inserted from the lexicon into the surface position (an A’-position). That is, topicalization in Korean cannot be accounted for in just one way: either movement or non-movement. In fact, we need both of them.

Within the feature-checking theory of Chomsky (1995) which dispenses with D- and S-Structures, on the other hand, we can exploit both the movement analysis of the theta-marked topic (argument topic) and the non-movement analysis of the non-theta marked topic (non-argument).

In this thesis I attempt to unify these two analyses (movement and base-generation) in terms of the feature-checking procedure (Chomsky 1995): the phrase having a [+topic] feature can be inserted into [Spec,MP] by ‘Merge’ directly from the lexicon (or base-generation) or be raised into [Spec,MP] by ‘Move’ from a lower position than [Spec,MP].

This Chapter consists of four Sections. Section 4.1 identifies the nature of topics in Korean. The topic is identified as appearing sentence-initially and as having the topic marker *un/nun* which is attached to the topic noun phrase.

Section 4.2 examines previous analyses of topicalization.

In Section 4.3, I consider topicalization in terms of the feature-checking theory. I propose that the topic in Korean appears into [Spec,MP] either by ‘Merge’ (non-movement) or by ‘Move’ (movement).



In Section 4.4, I consider why double topics are not allowed in a clause and why a topic is not allowed in a relative clause.

#### 4.1. Identification of Topic in Korean

According to I.-S. Yang (1972), the element in clause<sup>2</sup>-initial position can be identified as a topic, and therefore the topic is not necessarily marked by the particle *nun* only, but any clause-initial NP is a topic. However, based on the examples in (3), S.-Y. Bak (1981) argues that the syntactic notion of topic as the clause-initial element is not adequate for Korean.

- (3) a. Pi-ka on-ta.  
rain-Nom come-Dec  
'It is raining.'
- b. \* Pi-nun on-ta.  
rain-Top come-Dec

If we follow I.-S. Yang's (1972) argument, the impossibility of such a sentence as (3b) cannot be accounted for; if the clause-initial element is a topic, why cannot *pi* 'rain' in (3b) take the topic marker *un/nun* ?

- (4) a. Na-nun/nay-ka hankwukin-i-ta.  
I-Top/I-Nom Korean-be-Dec  
'I am a Korean.'
- b. Paris-nun/ka France-uy swuto-i-ta.  
Top/Nom Gen capital-be-Dec  
'Paris is the capital of France.'

---

<sup>2</sup> Here 'clause' indicates 'matrix clause' not 'embedded clause'.

D.-W. Yang (1975) and Kuno (1973) identify the topic in Korean and Japanese as the sentence-initial NP followed by the particle *nun* and *wa*, respectively. This implies that the NP followed by *i/ka* is not a topic but the NP with *un/nun* is a topic, as in (4). In this thesis, following D.-W. Yang (1975), I characterise the topic in Korean as appearing in the sentence initial position and as having the *un/nun* particle, as exemplified in (5) and (6) below.

- (5) Jane-i John-ul salanghan-ta.  
       Nom     Acc love-Dec  
       ‘Jane loves John.’
- (6) a. **Jane-un** John-ul salanghan-ta.  
        Topic    Acc love-Dec  
        ‘As for Jane<sub>i</sub>, she<sub>i</sub> loves John.’
- b. **John-un** Jane-i salanghan-ta.  
        Topic    Nom love-Dec  
        ‘As for John<sub>i</sub>, Jane loves him<sub>i</sub>.’

When Jane in (5) is topicalized, we have (6a); when John in (5) is topicalized, we have (6b). Thus throughout the thesis, I use the term ‘topic’ to refer to the sentence-initial nominal phrase followed by *un/nun*.

#### 4.1.1. The Notion of Topics with Reference to Relatives

According to S.-Y. Bak (1981), in a topic-comment structure in Korean, the topic is what the comment is talking ‘*about*,’ and in a noun phrase consisting of a relative clause and its head, the head is what the relative clause is talking ‘*about*’. The comment and the relative clause are predicated of the topic and of the relative head,

respectively. The speaker exploits ‘topic marking’ as a device for drawing the hearer’s attention to a particular nominal in a clause. That particular nominal is a *topic*, and the rest of the clause is a *comment* i.e. an explanation. Therefore using the topic marker twice in the same clause naturally causes a pragmatic difficulty in determining the speaker’s intention. According to S.-Y. Bak (1981), the relationship<sup>3</sup> between the *topic* and the *comment* is similar to that between the *relative head* and the *relative clause*. In a sense, the relative clause is a comment and the relative head is a topic, and therefore to put a topic inside a relative clause is to insert a topic in a comment. If we put a topic in a relative clause, this causes pragmatic confusion. S.-Y. Bak (1981) also explains the incompatibility of a topic with the relative clause in terms of the same pragmatic difficulty.

#### 4.1.2. Contrast between Topic Subject and Nominative Subject

In this Subsection, I examine the contrast between the topic marker *un/nun* and nominative marker *i/ka*. The examples in (7) and (8) are from S.-C. Shin (1987).

- (7) a. Cikwu-nun twungkul-ta.  
 earth-Top spherical-Dec  
 ‘The Earth is spherical.’ Or ‘As for the Earth, it is spherical.’
- b. Cikwu-ka twungkul-ta.  
 earth-Nom spherical-Dec  
 ‘The Earth is spherical.’ Or ‘It is the Earth that is spherical.’
- (8) a. Chwum-un Jane-i cal han-ta.  
 Dancing-Top Nom well do-Dec  
 ‘As for dancing, Jane does it well.’

---

<sup>3</sup> This idea was originally suggested by Kuno (1973) for Japanese and C.-M. Lee (1973) for Korean.

- b. \* Chwum-i Jane-i cal han-ta.  
Dancing-Nom Nom well do-Dec
- (9) a. Tal-ey-un salam-i salci-anhun-ta.  
moon-Loc-Top man-Nom live-not-Dec  
'On the moon, no men live.'
- b. \* Tal-ey-ka salam-i salci-anhun-ta.  
moon-Loc-Nom man-Nom live-not-Dec
- (10) a. Kawi-lo-nun cong-i-lul ccalun-ta.  
scissors-Inst-Top paper-Acc cut-Dec  
'With the scissors, one cuts the paper.'
- b. \* Kawi-lo-ka cong-i-lul ccalun-ta.  
scissors-Inst-Nom paper-Acc cut-Dec

The above examples show that the particle *i/ka* can occur only after the subject NP; the particle *un/nun* can occur with phrases (NPs or DPs or PPs) with which *i/ka* cannot occur. How can we expect a topic or a nominative subject to occur in a sentence? Consider the examples (from S.-C. Shin (1987)) below.

- (11) nwun-i on-ta. / \* nwun-un on-ta.  
snow-Nom come-Dec / snow-Top come-Dec  
'The snow comes/It is snowing.'
- (12) kolay-nun poyuryu-ta. / \*? Kolay-ka poyuryu-ta.  
whale-Top be mammal-Dec / whale-Nom mammal-Dec  
'A whale is a mammal.'

S.-C. Shin (1987) says that if no special contextual background is given, Korean native speakers typically expect the nominative marker *i* to occur after nwun 'snow' and the topic marker *nun* after kolay 'whale'. The occurrence of the topic marker *nun* in (12) can be accounted for in terms of 'aboutness'. The notion of 'aboutness' is associated with that of 'topic'. S.-C. Shin (1987) argues that the clause in (12) is a

statement about kolay ‘whale’; the clause in (11) is not a statement about nwun ‘snow’, but a description of the event of snowing. This argument implies that when a clause is taken to be a statement about the phrase XP (NP, DP, or PP), the occurrence of the topic marker is expected; otherwise the occurrence of the nominative marker is predicted. I am in agreement with Shin’s (1987) argument with respect to the occurrence of a topic or a nominative marker.

#### **4.1.3. Topic and Contrastive Focus**

Let us consider the notion of ‘topic’ with reference to that of ‘focus’. In this connection, D.-W. Yang (1973) states the notions of the topic and focus and difference between them, as follows.

--- contrastive FOCUS means singling out one object or event to be focused out of a set of more than one object or event, which the speaker presupposes to exist as possible candidates for the assertion being made of the focused object or event. Thus contrastive focus presupposes a set of objects or events from which a focus is to be picked up. Now suppose this set happens to be a one-member set. Then we would still be able to ‘pick’ one object or event, but it would not be a contrastive focus any longer, since the contrastiveness is lost and a contrastive focus with the contrastiveness factor eliminated is not a focus any longer. This seems to be precisely what happens in the case of topic; that is, intuitively the difference between topic and contrastive focus seems to be primarily the presence and absence of the contrastiveness factor, and the other factor seems to remain the same, e.g. both topic and contrastive focus single out one object or event for the hearer’s attention, and both are speaker-oriented notions in the sense that in both cases the speaker is more or less voluntarily or subjectively involved in choosing the one object or event for topic or contrastive focus.

In this thesis, I agree with D.-W. Yang (1973) with regard to the notions of topic and focus.

## 4.2. Previous Analyses in GB Framework

In this Section, I examine previous analyses of topicalization in GB framework. The analyses of topicalization in Korean may be divided into two groups: the first group argues for movement of a topic and the other argues for base-generation of a topic. Let us first consider topicalization in English before going on to Korean topicalization.

### 4.2.1. Topicalization in English

Chomsky (1977) proposes that in English an NP which is immediately dominated by S'' is a topic. The left-dislocated (LD) phrase in (13b), like the topic phrase in (13a), is also immediately dominated by S''.

- (13) a. [<sub>S'</sub> Himself<sub>i</sub>, [<sub>S'</sub> wh<sub>i</sub> [<sub>S'</sub> Peter likes t<sub>i</sub>]]  
          Top                  ↑          Move                  ↓
- b. [<sub>S'</sub> Mary<sub>i</sub>, [<sub>S'</sub> Peter likes her<sub>i</sub>]]  
              LD

Topicalization in (13a) is taken to involve invisible wh-movement; 'Himself' is base-generated in [Spec,S''<sup>4</sup>], but an invisible wh-phrase<sup>5</sup> is moved from the object position

---

<sup>4</sup> In the CP-structure, the position of topic and LD in (13) would be equivalent to [Spec,CP].

<sup>5</sup> The wh-phrase in (13a) is not visible.

of the verb and adjoined to S', relating the topic Himself and the clause Peter likes. In contrast, Mary which is left-dislocated and the pronoun her are both base-generated and there is no wh-movement; in the LD construction, there is no gap and no island effects, as in (14a). However, the topic construction involving invisible wh-movement shows island effects<sup>6</sup>, as in (14b) (from Y.-S. Kim (1988)).

(14) a. This flower<sub>i</sub>, I accept the argument that John should buy it<sub>i</sub>.

b. \* This flower, [wh<sub>i</sub> [ I accept [NP the argument that John should buy t<sub>i</sub>. ]]]

That is, English topicalization involves wh-movement but LD does not. The topic phrase is base-generated in the sentence-initial position by the phrase structure rules while an (invisible) wh-phrase moves, as illustrated in (13a). Chomsky (1982) later assumes that topicalization involves movement of an empty operator rather than an invisible wh-phrase: the topic is base-generated in the sentence-initial position as before and is predicated of the sentence through the mediation of the empty operator in Comp at S-Structure, as in (16).

(15) Mary, John loves

(16) a. Chomsky (1977)

---

<sup>6</sup> If Subjacency is a constraint on movement (see Chomsky (1982), Koopman and Sportiche (1982), and Lasnik and Saito (1984)), the topicalization of this flower in (14b) violates Subjacency, since the invisible 'wh-entity' is moved out of the complex NP. In contrast, LD in (14a) does not violate Subjacency, since there is no gap and no movement involved.

S'' --> Top S'  
 S' --> Comp S  
 DS: [<sub>S''</sub> Mary [S' Comp [S John loves **Whom**<sup>7</sup>]]]  
 SS: [<sub>S''</sub> Mary [S' **Whom**<sub>i</sub> [S John loves t<sub>i</sub> ]]]

b. Chomsky (1982)

DS: [ Mary [ Comp [ John loves **Op** ] ]]  
 SS: [ Mary [ Comp **Op**<sub>i</sub> [ John loves t<sub>i</sub> ] ] ]

On the other hand, Baltin (1982) analyses topicalization in English as adjunction to S. He furthermore argues that Chomsky's topicalization analysis is incorrect, and that instead the topic itself must move and adjoin to S; that is, the topic phrase itself must move from its original position to the surface position and not involve the movement of a wh-phrase or an empty operator.

## 4.2.2. Topicalization in Korean

### 4.2.2.1. Movement Analysis

Saito (1985) proposes that topicalization is a subcase of scrambling which has to be analysed as S-adjunction (cf. Kuroda (1985)). Fukui (1986) assumes a very defective category I and proposes that topicalization is an I'-adjunction.

Let us consider the contrast between (17a) and (17b). If the topic construction involves movement, the contrast can be accounted for (examples from D.-W. Yang (1973)).

- (17) a. [<sub>CP</sub> i salam<sub>i</sub>-un [<sub>IP</sub> Peter-ka t<sub>i</sub> manna-ss-ta.]]  
           This man-Topic                   Nom       meet-Pst-Dec  
           'As for this man, Peter met (him).'

---

<sup>7</sup> This wh-phrase (whom) is not visible.



- b.\* [CP i salam<sub>i</sub>-un [IP Peter-ka ku-lul<sub>i</sub> manna-ss-ta.]]  
 this man-Top Nom he-Acc meet-Pst-Dec  
 ‘As for this man<sub>i</sub>, Peter met him<sub>i</sub>.’

If the topic John is base-generated in [Spec,CP], ku-lul ‘him’ in (17b) can be inserted because the position where ku-lul appears is not a trace position but an empty position. But as the example indicates, (17b) is ungrammatical, implying that the position should be a trace position. The contrast in grammaticality between (17a) and (17b) cannot be accounted for without movement. Conversely the movement theory can explain the interpretive relationship between the topical phrase and its trace, as illustrated in (18) and (19) (from D.-W. Yang (1973)).

- (18) [ John-i i salam-ul ttayly-ess-ta.]  
 Nom this man-Acc hit-Pst-Dec  
 ‘John hit this man.’

- (19) a. i salam<sub>i</sub>-un [John-i t<sub>i</sub> ttayly-ess-ta.]  
 this man-Top Nom hit-Pst-Dec  
 ‘As for this man, John hit (him).’

- b. John<sub>i</sub>-un [ t<sub>i</sub> i salam-ul ttayly-ess-ta.]  
 John-Nom this man-Acc hit-Pst-Dec  
 ‘As for John, he hit this man.’

The thematic relationship between the topic phrase and the verb can be accounted for by the assumption of movement of the topic phrase to its surface position.

#### 4.2.2.2. Base-Generation Analysis

Y.-S. Kang (1986) argues that Korean topics must be base-generated in the left-most topic node, since they allow for resumptive pronouns and violate CNPC and

Subjacency. If the topic phrase involves movement, as argued in (17)-(19), how can we explain the presence of casin ‘himself’ in (20b) ? Under the movement theory, the empty position in (20a) should be filled by a trace left by ku-nun ‘he-Top’ which has moved to the sentence-initial position. However, the empty position can be filled by a lexical item casin ‘himself,’ as shown in (20b) (from D.-W. Yang (1973)).

(20) a. [CP ku-nun [IP [e] ku il-ul hay-ss-ta.]]  
           he-Top                          the job-Acc do-Pst-Dec  
           ‘He did the job.’

      b. [CP ku-nun [IP casin-i          ku il-ul          hay-ss-ta.]]  
           he-Top          himself-Nom  the job-Acc  do-Pst-Dec  
           ‘He did the job himself.’

The above examples in (20) support the claim that the topic construction should be base-generated. If ku-nun ‘he-Top’ in (20) is moved from the subject position in IP, casin-i ‘himself-Nom’ cannot be inserted since the subject position is filled by the trace left by the moved ku-nun ‘he-Top’. The same analysis can be applied to (21).

(21) Ku il-un [ Mary-ka taumtaley (ku kes<sub>i</sub>-ul) halye] ko sayngkakhakoiss-ta.  
       the job-Top      Nom next month the job-Acc do Comp think-Dec  
       ‘As for the job, Mary is thinking of doing it next month.’

The topic phrase in (21) allows the occurrence of a resumptive pronoun. This implies that the topic phrase is not moved from the gap position but is base-generated in the current position. The example in (21) implies that ku il ‘the job’ does not move from the position filled by ku kes ‘it’ to the surface position. Now let us consider the

example (22) where the resumptive pronoun is not allowed, unlike (21). I reproduce the following examples in (22) from D.-W. Yang (1973).

- (22) a. Seoul<sub>i</sub>-ey [ Mary-ka taumtaley t<sub>i</sub> kalye] ko sayngkakhakoiss-ta.  
           Loc          Nom next month go Comp think-Dec  
           ‘It is Seoul that Mary is thinking of going to (there) next month.’
- b. \* Seoul<sub>i</sub>-ey [ Mary-ka taumtaley keki<sub>i</sub>-ey kalye] ko sayngkakhakoiss-ta.  
           Loc          Nom next month there-Loc go Comp think-Dec  
           ‘It is Seoul that Mary is thinking of going to there next month.’

Crucially, the sentence-initial phrase in (22) is not marked with *nun*. That is, the example in (22b) does not involve topicalization but just scrambling of Seoul-ey ‘to Seoul’ (or movement). A resumptive pronoun is not allowed in the gap of the scrambled element, since scrambling involves movement. Therefore the resumptive pronoun in the gap position is not permitted since the gap position is already filled by a trace. Now we can account for the contrast between (21) and (22) by topicalization involving non-movement and scrambling involving movement, respectively.

The topic construction in (23b) is not subject to island constraints but the scrambling construction in (23a) is. I reproduce the following examples from G.-S. Moon (1987). The grammaticality judgement also is G.-S. Moon’s.

- (23) a. \* ce moca<sub>i</sub>-lul John-i [<sub>RC</sub> t<sub>i</sub> ssuko-i-ss-ten] salam-ul cal alkoiss-ta.  
           that hat-Acc      Nom wear-be-Pst-AM person-Acc well know-Dec  
           ‘That hat, John knows the person who was wearing it well.’
- b. ce moca<sub>i</sub>-nun John-i [<sub>RC</sub> e<sub>i</sub> ssuko-i-ss-ten] salam-ul cal alkoiss-ta.  
           that hat-Top      Nom wear-be-Pst-AM person-Acc well know-Dec  
           ‘As for that hat, John knows the person who was wearing it well.’

The scrambled phrase ce moca-lul ‘that hat’ in (23a) is moved out of the relative clause, resulting in a CNPC violation. In contrast, the topicalized ce moca-nun ‘that hat’ in (23b) is base-generated in the surface position. If the topic were moved out of the relative clause, it would violate the CNPC. Unlike (23a), (23b) is grammatical. This is another piece of evidence for the base-generation of the topic construction in Korean.

Kuno (1972) also points out that there is a problem with the movement approach, by presenting the topical sentences like (24a,b). It is not possible to argue that kkot ‘flower’ or mullihak ‘physics’ involves movement.

- (24) a. Kkot-un [cangmi-ka ceyil-i-ta.]  
 Flower-Top rose-Nom first-be-Dec  
 ‘Speaking of flowers, roses are the best.’
- b. Mullihak-un [chwicik-i elyep-ta.]  
 physics-Top employment-Nom difficult-Dec  
 ‘Speaking of physics, finding a job is difficult.’

Given this problem with the movement approach to topicalization, a natural alternative approach is to argue for the base-generation of the topic element in the surface (sentence-initial) position. The topic construction in Korean is different from the scrambling construction which involves movement in that the former may appear with resumptive pronouns, whereas the latter may not.

Based on Kuno (1972), D.-W. Yang (1973) postulates that the deep structure of a topical sentence embeds its corresponding non-topical sentence, as in (25) (from D.-W. Yang (1973)).

- (25) *i salam-un* [<sub>s</sub> John-i *i salam-ul* manna-ss-ta.]  
 This man-Top Nom this man-Acc meet-Pst-Dec  
 ‘As for this man, John met this man.’

The topicalization rule then deletes the object NP *i salam* ‘this man’ under coreference with the topic NP. This account does not involve movement. The relationship between the topic and coreferential NP as in (25) can be explained in terms of the coreferential NP deletion.

However, the non-movement analysis of D.-W. Yang (1973) still cannot explain the contrast between (26a) and (26b). (25) and (23b) are repeated as (26a) and (27) below, respectively.

- (26) a. *i salam-un* [John-i *i salam-ul* manna-ss-ta.]  
 This man-Topic Nom this man-Acc meet-Pst-Dec  
 ‘As for this man, John met (him).’

- b.\* *i salam<sub>i</sub>-un* [John-i *ku-lul<sub>i</sub>* manna-ss-ta.]  
 this man-Top Nom he-Acc meet-Pst-Dec  
 ‘As for this man, John met him/himself.’

- (27) *ce moca<sub>i</sub>-nun* John-i [<sub>RC</sub> (*ku-kes<sub>i</sub>-ul*) *ssuko-i-ss-ten*] *salam-ul* *cal alkoiss-ta*.  
 that hat-Acc Nom the-thing-Acc wear be-Pst-AM person-Acc well know-Dec  
 ‘As for that hat, John knows the person who was wearing it well.’

D.-W. Yang (1973) suggests that the pronominal-deletion is obligatory in (26b) but optional in (27). But this explanation is ad-hoc. He does not explain why that is so.

Now we are faced with a dilemma: examples like (17a) and (19) should involve movement but examples like (20b), (21), (24) and (27) involve base-generation in the surface position.

### 4.2.2.3. Saturation or Licensing Analysis

Y.-S. Kim (1988) proposes that Korean topicalization is an instance of a “Licensing” or “Saturation” process. She assumes that the Korean topic has a [+topic] feature and the [+topic] feature is one of the agreement features appearing in the Infl node. She argues that the feature [+topic] in Infl node licenses the Specifier positions of IP or VP and this Specifier position must be filled with an element with a topic feature for Saturation; the VP-internal subject receives the topic feature from Infl without moving to Spec,IP under head-government. However, the object remaining within a VP, cannot receive the topic feature from Infl since the head-government condition is violated. Therefore the object must be moved to the Spec,IP to receive the [+topic] feature, resulting in an asymmetry between subject and object concerning topic feature licensing.

In addition, Y.-S. Kim (1988) suggests that three options for topicalization exist in complementary distribution in Korean: (i) the movement analysis for the object topics as in (28); (ii) the base-generation analysis for subject topics as in (29); (iii) insertion at S-Structure for the non-argument extrinsic topic, as in (30). The example (2) is repeated as (30).

(28) [<sub>IP</sub> Mary<sub>i</sub>-nun [<sub>VP</sub> John-i [<sub>V'</sub> t<sub>i</sub> salanghan-ta.]]] -----Movement  
                   Top                  Nom          love-Dec  
                   ‘As for Mary, John loves her.’

(29) [<sub>IP</sub> [<sub>VP</sub> John-un Mary-lul salanghan-ta.]] ----- Base-generation  
                   Top          Acc love-Dec  
                   ‘As for John, he loves Mary.’

(30) [<sub>IP</sub> Sayngsun-un [<sub>VP</sub> coki-ka                  choykoi-ta.]] ---- Insertion at S-structure  
                   fish-Top          redsnapper-Nom best-Dec  
                   ‘As for fish, redsnapper is best.’

These three options are unified under a ‘Saturation’ or ‘Licensing’ process. Y.-S. Kim (1988) compares English subjects with Korean topics in terms of ‘Licensing’.

(31) English Subject

- a. Movement of subject from [Spec,VP] to [Spec,IP]
- b. Base-generation -- postverbal subject constructions
- c. Insertion -- Expletives like ‘it’

↓

“Saturation” or “Licensing”

(32) Korean Topic

- a. Movement of non-subject topic from within VP to [Spec,IP]
- b. Base-generation -- subject topic constructions
- c. Insertion -- non-theta marked topic constructions

↓

“Saturation” or “Licensing”

Now with the ‘Saturation’ or ‘Licensing’ process, we can solve the dilemma: some examples involve movement and some examples involve base-generation. In the next Section, I attempt to unify the asymmetric topic-marking for subject and object in terms of the feature-checking theory (Chomsky 1995). Unlike Y.-S. Kim (1988), I propose that the subject and object alike move to [Spec,MP] to check the topic feature, and the non-thematic topic like kkot ‘flower’ in (24) is inserted into [Spec,MP] from the lexicon.

### 4.3. Topicalization within the Framework of the Minimalist Program

In this Section, I try to account for topicalization in Korean in terms of ‘Merge’ and ‘Move’ in the framework of the minimalist program (Chomsky 1995) which is outlined in Section 1.2. above, and show how the dilemma between the movement analysis and the base-generation analysis can be solved.

#### 4.3.1. Topic Constructions within the Feature-Checking Theory

Let us begin by recalling topic constructions which we already considered. (41) and (42) in Chapter 1 are repeated here as (33) and (34) below.

(33) [<sub>TopP</sub> *kkot-un* [<sub>T</sub> *T*] [*tulip-i ceyili-ta.*]]  
flower-Top tulip-Nom best-Dec  
‘As for flower, tulips are the best.’

(34) a. [<sub>TopP</sub> [*John<sub>i</sub>-un*] [<sub>T</sub> *T*] [*i salam-i t<sub>i</sub>/\*ku<sub>i</sub>-lul po-ass-ta.*]]  
Top this man-Nom he-Acc see-Pst-Dec  
‘As for John<sub>i</sub>, this man saw him<sub>i</sub>.’

b. [<sub>TopP</sub> [*John<sub>i</sub>-un*] [<sub>T</sub> *T*] [*t<sub>i</sub>/??ku<sub>i</sub>-ka i salam-ul po-ass-ss-ta.*]]  
Top / he-Nom this man-Acc see-Pst-Dec  
‘As for John<sub>i</sub>, he<sub>i</sub> saw this man.’

In (33) movement is not involved. *Kkot* ‘flower’ is inserted directly from the lexicon by ‘Merge’ to check the topic feature of T. By contrast, *John* in (34a) seems to be moved to the current position by ‘Move’ from the object position; *John* in (34b) seems to be raised to the surface position from the subject position.

I suggest that the position of topic is fixed in Korean: it always appears in the (matrix) sentence-initial position, unlike in Y.-S. Kim (1988) where a topic can appear



in [Spec,IP] or [Spec,VP], depending on whether it is subject or object. In addition, it must have the topic marker *un/nun*. The question is now what the sentence-initial position provisionally notated TopP is: is it [Spec,CP] or [Spec,IP] or is it indeed something else?

#### 4.3.2. The Position of Topic Phrases

As in Chapter 2, I follow Whitman's (1989) argument that Korean clause structure is [CP [MP [TP [VP ]]]]. Furthermore, J.-Y. Yoon (1990) argues that Korean TP can be split into TP and AgrP<sup>8</sup>: [TP [AgrsP [ VP ]]], as seen in Chapters 1 and 2.

In the minimalist program, the nominative case feature<sup>9</sup> of the subject is checked in [Spec,AgrsP] by the corresponding feature of the verb adjoined to the head of AgrsP, and the Accusative case feature of the object is checked in [Spec,Agr<sub>o</sub>P] against a corresponding feature borne by the verb adjoined to Agr<sub>o</sub>. Notice that the subject and object move overtly to the Spec positions of AgrP but the verb raises in LF.

The question then arises about where the topic phrase appears: [Spec,CP] or [Spec,MP]. The [Spec,AgrsP] is excluded, since [Spec,AgrsP] is the position where the nominative marked subject occurs.

---

<sup>8</sup> AgrP is again split into AgrsP and Agr<sub>o</sub>P.

<sup>9</sup> I assume that Korean Tense is not involved in Nominative case-checking unlike English tense. See J.-Y. Yoon (1990) for a detailed discussion of nominative case-assignment in Korean.

Based on the examples in (35) and (36), J.-Y. Yoon (1990) argues that topic marked quantifier phrases always have wide scope over the negative operator, whereas the negative operator has wide scope over a nominative marked quantifier phrase. In addition, the topic marked universal quantifier in (35a) must have wide scope (as in (35b)) over the existential quantifier while the nominative marked universal quantifier in (36a) can have either wide scope (as in (36b)) or narrow scope (as in (36c)) over the existential quantifier (examples from J.-Y. Yoon (1990)).

(35) a. Motun salam-un etten salam-ul salanghan-ta.  
 Every man-Top some man-Acc love-Dec

b. 'Everyone loves someone.'

c. \* 'There is someone who is loved by everyone.'

(36) a. Motun salam-i etten salam-ul salanghan-ta.  
 Every man-Nom some man-Acc love-Dec

b. 'Everyone loves someone.'

c. 'There is someone who is loved by everyone.'

From these observations, J.-Y. Yoon (1990) concludes that the topic phrase should be above the nominative case marked phrase, strongly suggesting that in Korean the topic appears in [Spec,CP], and the nominative marked phrase in [Spec,IP] (or [Spec,Agr<sub>S</sub>P]).

Before adopting this conclusion, however, it is worth examining Korean wh-constructions. Watanabe (1992) argues that wh-in-situ in Japanese involves syntactic movement of an invisible entity. Operator in [Spec,CP] is moved from the IP-internal wh-phrase. If we follow Watanabe's (1992) idea on wh-phrase in Japanese, the wh-

feature of a wh-phrase in Korean can also move to [Spec,CP]. Then the movement of a wh-feature into [Spec,CP] blocks the topic phrase from raising to [Spec,CP], in an interrogative sentence. The wh-feature and the topic phrase compete for the same position. Watanabe (1992) supposes that a Japanese interrogative in fact involves invisible syntactic movement, as illustrated in (37);

(37) [CP Op<sub>i</sub> [C<sup>0</sup> Q] [IP .. wh-phrase<sub>i</sub> ...]]

C<sup>0</sup> requires one and only one Op to occupy [Spec,CP]. Consider the contrast between (38a) and (38b) (from J.-Y. Yoon 1990).

- (38) a. John-wa [Mary-ka nani-o katta ka dooka] dare-ni tazuneta-no ?  
           Top      Nom what-Acc bought whether who-Dat asked-Q  
           ‘Who<sub>i</sub> did John ask t<sub>i</sub> whether Mary bought what ?
- b.?? John-wa [Mary-ka nani-o katta ka dooka] Tom-ni tazuneta-no ?  
           Top      Nom what-Acc bought whether Dat asked-Q  
           ‘What<sub>i</sub> did John ask Tom whether Mary bought t<sub>i</sub> ?

Given the idea of Watanabe (1992) on the movement of wh-feature, in (38a) the wh-feature in the matrix clause moves to [Spec,CP] of the matrix clause. In contrast, in (38b) the wh-feature in the embedded clause moves to [Spec,CP] of the matrix clause crossing another wh-phrase ka dooka ‘whether’. The wh-island effect in (38) is attributed to syntactic movement of an invisible wh-feature (entity).

Based on this Watanabe’s (1992) idea and Chomsky’s (1995) idea of feature movement, I argue that in interrogative clauses in Korean (and Japanese), the wh-feature of the lexical elements like nwukwu ‘who’, mwuet ‘what’, eti ‘where’ should

move to the nearest C position whose head contains the corresponding Q-feature, even though the interrogative pronouns themselves do not move but remain in situ. The difference between Korean and English is that Korean involves the movement of a wh-feature only, while English requires the movement of the whole element including a wh-feature, namely pied-piping. Given this wh-feature movement to [Spec,CP] based on Watanabe (1992) and the assumption that the topic phrase appears in [Spec,CP], the topic phrase and the wh-phrase compete for the same position. But if we have recourse to feature movement which is to  $X^0$ , assumed in Chomsky's (1995) feature-checking theory, a topic and a wh-feature do not compete for a position since the topic moves to [Spec,CP] while the wh-feature moves to  $C^0$ . Therefore, following feature movement to  $X^0$  but not to [Spec,XP], I assume that any head associated with a [+wh] feature, which is essentially a Focus feature, is incompatible with a Topic feature.

Furthermore the following examples in (39) illustrate that the topic cannot have wide scope over the wh-phrase (example from Y.-S. Kim (1988)).

- (39) a. Mary-nun John-i salanghan-ta.  
           Top      Nom love-Dec  
           ‘As for Mary, John loves her.’  
           (Mary y (John x (love (x, y))))
- b. Mary-nun nuwkwu-ka salangha-ni ?  
           Top who-Nom love-Q  
           ‘As for Mary, who does love her ?’  
           (Nwukwu x (Mary y (love (x, y))))  
           \* (Mary y (nwukwu x (love (x, y))))

According to Y.-S. Kim (1988), in a sentence like (39a), the topic Mary has wide scope over the subject nwukwu-ka ‘who’; however, in (39b), the topic cannot have

wide scope over the wh-phrase. This implies that the topic feature cannot appear together with a wh-feature in the same position, and that the wh-feature or phrase has wide scope over the topic feature or phrase. Based on Szabolcsi's (1987) argument that Comp is not the source of [+definite], Y.-S. Kim (1988) claims that Korean topics are [+definite], and therefore that the topics cannot appear in the Specifier position of CP, presenting the following example in (40) as a piece of evidence.

- (40) \* Nwukwu-nun Mary-ka cohahan-ta.  
 Someone-Top Nom like-Dec  
 'As for someone<sub>i</sub>, Mary likes him<sub>i</sub>/her<sub>i</sub>.'

Therefore, as an alternative to [Spec,CP], I propose that Korean topic phrases appear in [Spec,MP], occurring between CP and Agr<sub>S</sub>P.

Y.-S. Kim (1988) notes that if a topic and a wh-phrase occur in different positions in a clause, the topic and wh-phrase can co-occur in the same sentence, as illustrated in (41)-(44) which are reproduced from Y.-S. Kim (1988).

- (41) a. [ John-un [IP Mary-lul cohahan-ta.]]  
           Top                  Acc like-Dec  
           'As for John, he likes Mary.'
- b. [ Mary-nun [IP John-i cohahan-ta.]]  
           Top                  Nom like-Dec  
           'As for Mary, John likes her.'
- (42) a. [CP Nuwkwu-ka [C +Wh] [IP Mary-lul cohahanu-nya ?]]  
           who-Nom                                  Acc like-Question  
           'Who likes Mary ?'
- b. \* [CP Nuwkwu-nun [C +Wh] [IP Mary-lul cohahanu-nya ?]]  
           who-Top                                  Acc like-Q



#### 4.4. Why Not a Topic in an RC ?

##### 4.4.1. No Double Topics in a Clause

S.-C. Shin (1987) says that one of the syntactic characteristics of the topic marker is a constraint against the occurrence of more than one topic in a clause. Consider the examples shown below, where the topic marker is used twice in a clause. (45b) is odd. The examples in (45) are from S.-C. Shin (1987).

- (45) a. Mary-nun son-i yeppu-ta.  
Topic hand-Nom pretty-Dec  
'Mary's hands are pretty/ Mary has pretty hands.'
- b. ?? Mary-nun son-un yeppu-ta.  
Top hand-Top pretty-Dec  
(A forced reading: 'Mary's hands are pretty  
but the other parts are not pretty.')

S.-C. Shin (1987) argues that the oddity in (45b) is due to the fact that two topic markers are not allowed in one sentence. In other words, if the speaker makes use of topic marking to draw hearer's attention to a particular phrase in a clause, the usage of two topics naturally causes a pragmatic (perceptual) difficulty in understanding the speaker's intention. Based on this pragmatic reason, S.-Y. Bak (1981) posits the following condition.

##### (46) The Condition on topic constructions

A clause consisting of a topic and a comment cannot contain more than one topic phrase.

The above condition on topic structures should be rewritten as follows within the feature-checking theory which we adopt.

- (47) A clause consisting of a topic and a comment cannot contain more than one topic feature (the topic feature can only be checked once).

#### 4.4.2. No Topic in a Relative Clause

The occurrence of the topic marker in relative clauses is constrained by the same condition applying to the occurrence of double topics that we have just observed above. Consider the following examples (from S.-Y. Bak, 1984).

- (48) a. *i salam-i* [<sub>RC</sub> *John-i chayk-ul cwun-n*] *Mary-i-ta.*  
 This man-Nom Nom book-Acc give-AM be-Dec  
 ‘This is Mary whom John gave (the) book to.’
- b. \* *i salam-i* [<sub>RC</sub> *chayk-un John-i cwun-n*] *Mary-i-ta.*  
 This man-Nom book-Top Nom give-AM be-Dec  
 ‘This is Mary whom (the) book John gave to.’
- c. \* *i salam-i* [<sub>RC</sub> *John-un Chayk-ul cwun-n*] *Mary-i-ta.*  
 This man-Nom Top book-Acc give-AM be-Dec  
 ‘This is Mary whom John gave (the) book to.’
- (49) a. [<sub>RC</sub> *John-i Mary-lul manna-n*] *hakkyo-ka phakoytoy-ess-ta.*  
 Nom Acc meet-AM school-Nom be destroyed-Pst-Dec  
 ‘The school where John met Mary was destroyed.’
- b. \* [<sub>RC</sub> *John-un Mary-lul manna-n*] *hakkyo-ka phakoytoy-ess-ta.*  
 Top Acc meet-AM school-Nom be destroyed-Pst-Dec  
 ‘The school where John met Mary was destroyed.’
- c. \* [<sub>RC</sub> *Mary-nun John-i manna-n*] *hakkyo-ka phakoytoy-ess-ta.*  
 Top Nom meet-AM school-Nom be destroyed-Pst-Dec  
 ‘The school where Mary John met was destroyed.’
- (50) a. [*Ku totwuk-ul capwu-n*] *swunkyong-i sang-ul pat-ass-ta.*  
 The thief-Acc catch-AM policeman-Nom prize-Acc receive-Pst-Dec  
 ‘The policeman who caught the thief was rewarded.’



- b. \* [Ku *totwuk-un* capwu-n] swunkyong-i sang-ul pat-ass-ta.  
 The thief-Top catch-AM policeman-Nom prize-Acc receive-Pst-Dec  
 'The policeman who the thief caught was rewarded.'

The italicised elements in (48)-(50) are the topics within the relative clauses. The sentences in those examples all result in ungrammatical derivations. The following English examples in (51)-(53) (from Chomsky 1977) show the same phenomenon as in Korean examples

- (51) a. This is the boy [who John gave the book away to.]  
 b. \* This is the boy [who *the book*, John gave away to.]  
 (52) a. The man [who wrote the book] is a well-known linguist.  
 b. \* the man [who *the book*, wrote] is a well-know linguist.  
 (53) a. I love Mary [who was running after the dog].  
 b. \* I love [who *the dog*, was running after].

Again the italicised phrases in (51)-(53) are the topics in relative clauses and the resulting sentences are all unacceptable.

Based on the above observation, S.-Y. Bak (1981, 1984) explains the incompatibility of a topic with the relative clause in terms of a pragmatic, namely, perceptual principle.

The topic is to comment what the relative head noun is to the relative clause. If so, the relative clause seems to be a kind of comment with respect to its relative head and then the relative head can be said to have a topic feature. Given the Condition on topic constructions as in (47), the clause consisting of a relative clause

(comment) and its head (topic) having a topic feature cannot have a topic phrase in the same relative clause, since the relative head already has a topic feature. This accounts for why the relative clause cannot contain a topic phrase.

## CHAPTER 5

### CASE-MARKING IN DOUBLE NOMINATIVE CONSTRUCTIONS

This Chapter considers how case-marking takes place in the well-known Double Nominative Constructions (DNCs) in Korean, and argues that these constructions are derived from the locative construction. The Chapter is organised as follows. Section 5.1 presents some DNC examples. In Section 5.2, I show that Double Nominative Constructions are possible only with unaccusative verbs, following Suh (1993). Section 5.3 is concerned with Case-checking procedure for DNCs in Korean. In Section 5.4, discussing Double Accusative Constructions (DACs), I propose that DACs exploit multiple spec mechanism for accusative case marking unlike DNCs.

With respect to case-marking in DNCs, before going to my proposal (5.3.5) within the framework of Chomsky (1995), I will review previous discussions of DNCs in GB framework throughout Sections 5.1 and 5.2, and Subsections 5.3.1-5.3.4.

#### **5.1. Double Nominative Constructions**

Based on Freeze (1992) and Perlmutter (1978), I will show that the derivation in Korean DNCs is the same as that found in English Possessive, Existential and Locative sentences (see Fillmore (1968), Kuno (1971) and Lyons (1967) for details).

The DNCs seem to have a relationship with the following three kinds of structures: first, Possessive constructions, second, Locative existential constructions, and third, Ergative constructions (cf. Cinque 1990a), as exemplified below:

- (1) a. Mary-uy / ka                      son-i                      yeppu-ta.  
           Gen/Nom                      hand-Nom                      pretty-Dec  
           ‘Mary’s hand is pretty.’
- b. John-uy/ i                      hyeng-i                      pwuca-ta.  
           Gen/Nom                      brother-Nom                      rich-Dec  
           ‘John’s brother is rich.’
- (2) a. Seoul -ey<sup>1</sup> / i                      pul-i                      na-ss-ta.  
           Loc/ Nom                      fire-Nom                      break out-Pst-Dec  
           ‘A fire broke out in Seoul.’
- b. Hankwuk-ey/ i                      san-i                      manh-ta.  
           Loc/Nom                      mountain-Nom                      many-Dec  
           ‘In Korea there are a lot of mountains.’
- (3) a. Mary-eke/-ka                      kohyang-i                      kurip-ta.  
           Dat/Nom                      hometown-Nom                      miss(ergative verb)-Dec  
           ‘Mary misses her hometown.’
- b. Tom-i                      Mary-ka                      coh-ta.  
           Nom                      Nom                      like(ergative) Dec  
           ‘Tom likes Mary.’

With respect to Case-marking, I propose that the first NP marked nominative in DNCs should derive from locative position and move into [Spec,IP] (or [Spec,Agr<sub>S</sub>P]) to check its Nominative Case, and that the second NP marked nominative should remain within VP having its default Case (or inherent Case).

---

<sup>1</sup> The dative ‘eke’ for animate NPs and locative ‘ey’ for inanimate NPs expressing locative PP have the relationship of complementary distribution.

## 5.2. The Analysis of Verbs Allowing Double Nominative

Relying on the Unaccusative Hypothesis of Perlmutter (1978) and the Uniformity of Theta Assignment Hypothesis of Baker (1988), Suh (1993) provides an explanation for why DNCs in the Alienable Possession Constructions (APCs) are possible only with a certain type of predicate. Suh (1993) claims that double nominative constructions (or multiple nominative) can be found only with unaccusative verbs (or ergative verbs) which have only one theme object as an argument at D-structure.

### 5.2.1. The Notion of Intransitive Verbs

Intransitive verbs may be divided into two groups according to the position of argument: “*Unergatives*” and “*Unaccusatives*”. An unergative verb has one argument (NP) in [Spec,VP] (or subject position) and no object at D-structure, as in (4).

(4)  $[_{VP} \text{ NP } [_{V'} V^0]]$

An unaccusative verb has its only argument in the object (complement) position of VP and no subject, as in (5).

(5)  $[_{VP} [_{V'} V^0 \text{ NP } ]]$

Unergatives and unaccusatives are the same in the sense that they have only one argument. The difference is the position of where the argument appears at D-structure. If it appears in subject position, the verb is called *unergative*. If it occurs in object position, the verb is called *unaccusative* (or *ergative* in the sense of Burzio (1986)).

As for two argument verbs, in accusative languages (or accusative sentences) the grammatical subject is associated with a semantic role, Agent, and the object Patient, as in (6).

- (6) [<sub>VP</sub> *NP1* [<sub>V</sub> V<sup>0</sup> *NP2* ]]  
           Agent           Patient

In an accusative language such as English, the Agent subject is assigned Nominative Case and the Patient object Accusative Case.

### 5.2.2. Korean Data

Let us now consider the following Korean data (from Suh (1993) and Maling and Kim (1992)):

- |        |  |                         |                               |
|--------|--|-------------------------|-------------------------------|
| (7) a. | John -uy/i<br>Gen/Nom<br>'John's brother died.'  | hyeng -i<br>brother-Nom | cwuke-ss-ta.<br>die-Pst-Dec   |
| b.     | John -uy/*i<br>Gen/*Nom<br>'John's brother ran.' | hyeng -i<br>brother-Nom | talyeka-ss-ta.<br>run-Pst-Dec |

- (8) a. Mikwuk-ey/i                      cicin-i                      na-ss-ta.  
       America-Loc/Nom                  earthquake-Nom              occur-Pst-Dec  
       ‘An earthquake occurred in America.’
- b. Mikwuk-ey/\*i                      Tom -i                      san-ta.  
       America-Loc/Nom                  Nom                          live-Dec  
       ‘Tom lives in America.’

The difference between (7a) and (7b) (or (8a) and (8b)) is given by the structural representations, illustrated below:

- (9) a. (for 7a)  
       [<sub>VP</sub> [<sub>v</sub> hyeng-i                      cwuke-ss-ta.]]  
           brother-Nom                      die-Pst-Dec
- b. (for 7b)  
       [<sub>VP</sub> hyeng-i                      [<sub>v</sub> talyeka-ss-ta.]]  
           brother-Nom                      run-Pst-Dec
- (10) a. (for 8a)  
       [<sub>VP</sub> [<sub>v</sub> cicin-i                      na-ss-ta.]]  
           earthquake-Nom                  occur-Pst-Dec
- b. (for 8b)  
       [<sub>VP</sub> Tom-i                      [<sub>v</sub> san-ta.]]  
           Nom                                  live-Dec

Hyeng in (7a) and cicin in (8a) occur in the object position since they are “Themes”. On the other hand, hyeng in (7b) and Tom in (8b) occupy the subject position since they are “Agents”. Since, as shown in (9a) and (10a), the second NPs appear in the object position within VP and there is no subject in [Spec,VP], the verbs in these constructions are unaccusative verbs. Then we can refer to (7a) and (8a) as unaccusative constructions in which only one theme argument occurs in the object position at DS.

Next, let us consider the structural representations for the examples in (1), (2) and (3), as in (11)-(13):

- (11) a. [<sub>VP</sub> [<sub>V'</sub> son-i yepputa.]]  
       b. [<sub>VP</sub> [<sub>V'</sub> hyeng-i pwucata.]]
- (12) a. [<sub>VP</sub> [<sub>V'</sub> pul-i nassta.]]  
       b. [<sub>VP</sub> [<sub>V'</sub> san-i manhta.]]
- (13) a. [<sub>VP</sub> [<sub>V'</sub> kohyang-i kuripta.]]  
       b. [<sub>VP</sub> [<sub>V'</sub> Mary-ka cohta.]]

The above three structures can be said to be unaccusative constructions like (7a) and (8a). Gerdts and Youn (1989) show that the variety of Case patterns for locative existential verbs contrasts sharply with the very restricted pattern found in true locatives. Locative Case does not alternate with Nominative:

- (14) a. Kongcang-ey/ \*i      cangko-ey/ \* ka      John-i  
       factory-Loc/\*Nom      storeroom-Loc/\* Nom      Nom  
       myech sikan-ul      anca-iss-ta.  
       a few hours-Acc      sitting-be-Dec  
       ‘John is sitting in the factory storeroom for a few hours.’
- b. Mikwuk-ey/ \* i      sepu-ey/ \* i      John-i      salko-iss-ta.  
       America-Loc/ \* Nom      west-Loc/\* Nom      Nom      living-be-Dec  
       ‘John is living in the western part of America.’

If we assume that locative existential verbs are unaccusatives and true locative verbs are unergatives, the contrast between the locative existential ((2) and (8a)) and the true locative ((8b) and (14)) can be accounted for. This analysis leads us to argue that



the DNCs in Korean occur only in the unaccusative structure. The structure for (14) would then be as follows:

- (15) a. [<sub>VP</sub> Kongchang-ey [<sub>VP</sub> changko-ey [<sub>VP</sub> John-i [<sub>V'</sub> myech sikan-ul anca-iss-ta.]]]]  
 factory-Loc storeroom-Loc Nom a few hour-Acc sitting-be-Dec
- b. [<sub>VP</sub> Mikwuk-ey [<sub>VP</sub> sepu-ey [<sub>VP</sub> John-i [<sub>V'</sub> salko-iss-ta.]]]]  
 America-Loc west-Loc Nom live-ing-Dec

### 5.3. Case-Checking

#### 5.3.1. Direct Case-Checking or Indirect Case-Checking ?

Regarding so-called Double Nominative Constructions in Korean, the crucial question is: how is Nominative Case assigned to more than one NP in a DNC ? Most proposals may be classified into one of two positions. The first position is that Nominative Case is assigned to the second NP and then the first NP is Case-marked under Case-agreement between the first NP and second NP (or alternatively, Case is assigned to the outer NP and percolates from the outer NP to the inner NP under Case-percolation). This is called the Indirect Case-assignment Hypothesis (see J.-Y. Yoon (1990) for details). The second is that each Nominative NP receives Case independently by two different heads, namely the verb and Infl (or somewhere else) (see Maling and Kim (1992)). This is called the Direct Case-assignment Hypothesis.

#### 5.3.2. A Problem for the Indirect Case-Assignment Hypothesis

To account for Case-marking in Japanese DNCs, Tateishi (1988) argues that in certain instances Nominative Case percolates down to NP-Specifiers. He claims that

a sentential adverb can appear between the innermost ‘ga’-phrases; but not between the first two ‘ga’-phrases, as in (16) (from Tateishi (1988)).

- (16) **(totuzen)** John-ga **(\*totuzen)** computer-ga **(totuzten)**  
 (suddenly) Nom (suddenly) Nom (suddenly)  
 disk drive-ga kowareta.  
 Nom broke  
 ‘The disk drive of John’s computer has broken down.’

In other words, the first two NPs can form an NP constituent; this constituent receives Nominative Case from Infl, and then the Case can percolate down to the inner NP from the outer NP. The third NP receives Case from the Verb.

According to Heycock (1993), this prediction is not borne out. In the following grammatical sentences, sentential adjuncts (bold faced) may intervene between each contiguous pair of ‘ga’-phrases, indicating clearly that Case-marking in DNCs is not done through percolation or agreement, since Case cannot percolate from an NP to another NP (or cannot agree between two NPs) when something intervenes between them and therefore they are not constituents (examples (17) and (18) from Heycock (1993)).

- (17) a. bunmeikoku- ga **saikin** dansei-ga **zyosei-yori**  
 civilised-countries-Nom recently male-Nom female-than  
 heikinzyumyoo-ga mizikai.  
 average-life-span-Nom is-short  
 ‘In civilised countries recently the average life-span of men is shorter than that of women.’
- b. Sweden-ga **America-yori** kokumin-ga  
 Nom than people-Nom  
**ippan- ni- wa** me-ga warui.  
 general in Top eye-Nom is bad  
 ‘In Sweden, more than America, people generally have bad eyes.’

Indeed no sentential adjuncts can intervene between two NPs in genitive marking environments, where we can see overt evidence of constituency:

- (18) a. \* [bunmeikoku- no **saikin** dansei -ga]  
 civilised-countries -Gen recently male-Nom  
**zyosei-yori** heikinzyumyoo-ga mizikai.  
 female-than average-life-span-Nom is-short  
 ‘Men of civilised countries recently have shorter average life-span than women.’
- b. \* bunmeikoku- ga **saikin** [dansei -no  
 civilised-countries -Nom recently male-Gen  
**zyosei-yori** heikinzyumyoo-ga] mizikai.  
 female-than average-life-span-Nom is-short  
 ‘In civilised countries recently the average life-span of men is shorter than that of women.’

The corresponding Korean examples support the analysis of Heycock’s:

- (19) a. mwunmyengkwwukka-ka **choikuney** namseng-i  
 civilised countries-Nom recently male-Nom  
**yeseng-boda** pyenggyunswumyeng-i ccapta.  
 female-than average- life span-Nom is short  
 ‘In civilised countries recently the average life-span of men is shorter than that of women.’
- b. Sweden-i **America-boda** kwukmin-i  
 Nom than people-Nom  
**ilbancekuro** nun-i naputa.  
 generally eye-Nom is bad  
 ‘In Sweden, more than America, people generally have bad eyes.’
- (20) a. \* [mwunmyengkwwukka-uy **choikuney** namseng-i]  
 civilised-countries -Gen recently male-Nom  
**yeseng-boda** pyenggyunswumyeng-i ccapta.  
 female-than average-life-span-Nom is-short  
 ‘Men of civilised countries recently have shorter average life-span than women.’

- b. \* mwunmyengkukka-ka      **choikuney**      [namseng-uy  
civilised-countries -Nom      recently      male-Gen  
**yeseng-boda**      pyenggyunswumyeng-i]      ccapta.  
female-than      average-life-span-Nom      is-short  
‘In civilised countries recently the average life-span of men is shorter  
than that of women.’

The data in (17), (18), (19) and (20) support the conclusion that the Nominative NPs in DNCs receive their Case from the verb or from Infl independently of one another, not through Case-Agreement or Case-Percolation.

### 5.3.3. Evidence for the Direct Case-Assignment Hypothesis

Maling and Kim (1992) give us evidence in support of the Direct Case Hypothesis. They argue that the verb assigns Case independently to both the first NP and the second NP under the Direct Case Hypothesis. If Case-agreement is responsible for the shared Case-marking, then when such verbs are used in the Whole-Part<sup>2</sup> construction, we expect to find two possible Case patterns: the whole- and part- NPs should either be both Locative or Nominative. On the other hand, if these verbs can assign either Locative or Nominative to their locative subject argument, and Case is assigned independently to both whole- and part- NPs, then there are in principle four possible combinations of Locative and Nominative. It turns out that indeed, all four possible structures are, surprisingly, acceptable:

---

<sup>2</sup> In the Inalienable Possession Construction in Korean or Japanese, the possessor NP may be called the whole NP, and the possessed NP the part NP.

- (21) a. Kongcang-ey    changko-ey    pul-i    na-ss-ta.  
 Factory-Loc    storeroom-Loc    fire-Nom    break out-Pst-Dec  
 'A fire broke out in the factory in the storeroom.'
- b. Kongcang-i    changko-ka    pul-i    na-ss- ta.  
 Factory-Nom    storeroom-Nom    fire-Nom    break out-Pst-Dec
- c. Kongcang-i    changko-ey    pul-i    na-ss- ta.  
 Factory-Nom    storeroom-Loc    fire-Nom    break out-Pst-Dec
- d. (?) Kongcang-ey    changko-ka    pul-i    na-ss-ta.  
 Factory-Loc    storeroom-Nom    fire-Nom    break out-Pst-Dec
- (22) a. Mikwuk-ey    sepu-ey    cicin-i    na-ss-ta.  
 America-Loc    West-Loc    earthquake-Nom    occur-Pst-Dec  
 'An earthquake occurred in the western part of America.'
- b. Mikwuk-i    sepu-ka    cicin-i    na-ss-ta.  
 America-Nom    West-Nom    earthquake-Nom    occur-Pst-Dec
- c. Mikwuk-i    sepu-ey    cicin-i    na-ss-ta.  
 America-Nom    West-Loc    earthquake-Nom    occur-Pst-Dec
- d. (?) Mikwuk-ey    sepu-ka    cicin-i    na-ss-ta.  
 America-Loc    West-Nom    earthquake-Nom    occur-Pst-Dec

As Maling and Kim (1992) observe, the patterns in examples (c,d) where the Case-marking differs are unexpected under the Case-Agreement Hypothesis, but are consistent with the Direct Case Hypothesis. According to Maling and Kim (1992), further evidence that the Case on the part-NP (even in the Inalienable Possessive Constructions) is determined by the verb comes from the apparent alternation between Nominative and Accusative in the lexical passive, as illustrated in (23) and (24) (from Maling and Kim (1992)).

- (23) a. John-i            ai-lul    son-lul    capa-ss-ta.  
 Nom            child-Acc    hand-lul    hold-Pst-Dec  
 'John held the child by the hand.'

- b. Ai-ka            son-i/ul            cap-hie-ss-ta.  
 Child-Nom      hand-Nom/Acc      hold-Psv-Pst-Dec  
 ‘The child was held by the hand.’ -----> *lexical Passive*
- (24) a. John-i            son-i/\*ul            mul-lie-cie-ss-ta.  
           Nom            hand-Nom/\*Acc      bite-Psv-Psv-Pst-Dec  
 ‘John was bitten on the hand,’ -----> *ci-Passive*
- b. John-i            son-i/ul            mul-lie-ss-ta.  
           Nom      hand/Nom/Acc      bite-Psv-Pst-Dec  
 ‘John was bitten on the hand.’ -----> *lexical Passive*

The underlined part-NP bears Accusative or Nominative Case in the so-called lexical passive; in the syntactic ‘*ci*’-passive the part -NP can only be Nominative. If passive morphology (*ci*) always absorbs the Accusative Case of the object, then only Nominative Case can be visible on the part-NP. As an explanation for the source of Accusative in the lexical passive, Maling (1989) argues that the lexical passive verb may act both as a syntactic direct passive which absorbs Accusative Case and as an indirect ‘adversity’ passive which adds a benefactive subject argument and assigns Accusative Case to its complements. Anyhow, in the case of the lexical passive, we can account for the Case alternation under the Direct Case Hypothesis, but not under the Indirect Case Hypothesis.

#### 5.3.4. The Analysis of Locative Existentials and Ergative Constructions

Based on the ideas of Freeze (1992), Maling and Kim (1992), and Suh (1993), I argue that the first NP in locative or ergative constructions should be derived from a locative (or dative) position and assigned Nominative Case by Infl while the second NP remains within VP and gets default Case. This analysis can be rewritten in terms of feature-checking theory (Chomsky 1995) as follows: the first NP marked

Nominative case moves from its original position into [Spec,Agr<sub>3</sub>P] to check the Nominative case feature of I. According to Freeze (1992), the normal form of the locative existential has a locative phrase in subject position; the following existential expressions correspond to a single D-structure (examples in (25) from Freeze (1992)).

- (25) a. [IP There<sub>i</sub> [I' [I is] [PP [NP a book] [P' on the table.]<sub>i</sub> ]]]  
 Locative Theme
- b. [IP[P' na stole]<sub>i</sub> [I' [I byla] [PP[NP kniga] t<sub>i</sub> .]]](Russian data from Freeze)  
 on table was book.Nom.Fem(Theme)
- c. [IP[P' kamree-mee]<sub>i</sub> [I' [PP t<sub>i</sub> [NP aadmii]] [I hai.]]] (Hindi data from Freeze)  
 room-in man be(COP).3Sg.Masc.Prst.

Likewise, the DS representations for (2a) and (3a) in Korean may be the following:

- (26) a. [VP Seoul-ey [V' pul-i nassta.]]  
 Loc fire-Nom broke out
- b. [VP Mary-eke [V' kohyang-i kuripta.]]  
 Dat(Loc) hometown-Nom miss(ergative)

An alternative approach to locative existentials and ergative constructions makes use of small clauses. Hoekstra and Mulder (1990) propose the analysis in (27) and (28) for an ergative (or unaccusative) sentence of this type in (29) when the sentence takes a locative PP:

(27) D-structure: [<sub>VP</sub> Verb [<sub>SC</sub> NP PP ]]



(28) S-structure: NP<sub>i</sub> INFL [<sub>VP</sub> Verb [<sub>SC</sub> t<sub>i</sub> PP]]

(29) [<sub>NP</sub> Jan] is [<sub>PP</sub> in de sloot] [<sub>Verb</sub> gesprongen]

‘John is in the ditch jumped.’

NP is assumed to be inside the SC, as indicated by the structure in (27) and (28), and to raise into [Spec,IP] (or [Spec,Agr<sub>S</sub>P]) to get Nominative Case. This analysis suggests that the verb does not have an external argument. Then we can account for the movement of NP in accordance with Burzio’s generalisation requiring that if a verb does not have an external argument or does not assign a theta-role to its subject in the [Spec,VP] position, the object cannot be assigned Case by its verb.

With this analysis in mind, consider the constructions exemplified in (30) (from Hoekstra and Mulder (1990)).

- (30) a. Into the room [<sub>VP</sub> walked a man.]  
      b. Down the street [<sub>VP</sub> rolled the baby carriage.]  
      c. Round and round [<sub>VP</sub> spins the fateful wheel.]  
      d. There [<sub>VP</sub> arrived a man.]

Hoekstra and Mulder (1990) raise one crucial question: if we apply the analysis assumed in (27) and (28) to (30), why does (30) not violate the Case Filter or the Extended Projection Principle (this principle requires that the [Spec,IP] position must



be filled with an NP) ? Note that, in (30), there is no NP, in [Spec, IP] position and Nominative Case should be assigned to the [Spec,IP] position. Rizzi (1982) and Burzio (1986) assume that in Italian the Specifier position of IP is filled with *pro*, and that the postverbal NP is adjoined to VP and forms an expletive chain with *pro*. In (30) the *pro* then appears to be licensed by the locative PP which could be either adjoined to IP, or occupy the [Spec, CP] position, as illustrated in (31):

(31)  $PP_i [IP \text{ pro}_i [VP [VP ..V..] NP_i ]$

Rizzi (1982) explains that the PP is capable of licensing the pro-subject by virtue of a shared index. This kind of analysis has also been proposed by Coopmans (1988). It is generally held that locative preposing of this type is subject to an ergativity requirement (cf. Levin 1985). But the analysis in (31) does not explain this requirement. Hoekstra and Mulder (1990) argues that there is no special reason under this analysis why only an ergative verb can allow NP to be adjoined to VP, assuming that the NPs in (30) are in fact inside VP, as shown in (32), which explains the ergativity requirement naturally. Note that according to the ergativity requirement, the object can be moved out of VP only when the object cannot receive Case (or cannot check its case feature) from its verb within VP. They suggest that Nominative Case is assigned to the PP in the [Spec,IP] position as in (32a). The PP originates in the predicative part of a SC-complement. The NP is provided Nominative Case by PP under Spec-head agreement from its base position, as in (32b). Then the structure is like (32):

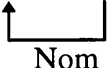
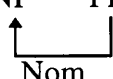
- (32) a.  $[_{IP} PP_i \quad I \quad [_{VP} V \quad [_{SC} NP \quad t_i ]]]$   

- b.  $[_{IP} [_{VP} V \quad [_{SC} NP \quad PP]]]$   

If we adopt this kind of analysis for Korean DNCs which have the unaccusative (ergative) verb structure, the structure for (26a) is as follows:

- (33) a.  $[_{VP} [_{SC} [_{NP} pul-i ] \quad [_{PP} Seoul-ey]] \quad nassta]$   

- b.  $[_{IP} [Seoul-i]_i \quad I \quad [_{VP} [_{SC} [_{NP} pul-i ] \quad [_{PP} [_{NP} t_i ] \quad [P \ e]]]] \quad nassta]]$

In the case of Korean, bare locative NPs move out of VP to somewhere (e.g. [Spec,Infl]) to check Case features. When P is realised, on the other hand, the movement does not occur under the Case Filter. That is, the case-checking procedure takes place between [Spec,PP] and P<sup>0</sup>. This means that the NP in [Spec,PP] need not move to somewhere to check its case feature since its case feature has already been checked by P<sup>0</sup>. If we assume the analysis in (33), we also need to explain how the NP inside the SC can get Case. If we suppose that a null headed PP can assign Case to its subject within the structure of SC, the Case assigned to NP in the Spec-position of SC may be said to be Structural Case. Another possible analysis is to assume the Exceptional Case Marking of NP by the main verb. In both cases, the Case assigned to NP is structural Case. This analysis in terms of structural Case-assignment, however, is undermined by the *indefinite* (or *non-specific*) character of the second

NP in Korean DNCs. If we assume that the second NP in DNCs has structural case, we cannot account for why the second NPs, as illustrated in (34) below, cannot be definite or specific. In other words, I assume that structural Case marked NPs are definite or specific<sup>3</sup>; however, the second NP in DNCs is obligatorily indefinite or non-specific.

Therefore within the framework of Chomsky (1995) I assume the structure in (34) for Korean DNCs:

(34) [<sub>VP</sub> [<sub>PP</sub> Locative] [<sub>V'</sub> NP Verb]]

This analysis solves the above problems. When a null P appears, a bare locative NP moves out of VP for Case reasons, as expected. We may assume that the locative NP raises into [Spec,IP] (or [Spec,Agr<sub>S</sub>P]) to check its case feature. But we still have to

---

<sup>3</sup> A similar analysis is presented in Chapter 2 concerning the movement of specific nouns in the DP structure. I argued that the movement of head nouns from N<sup>0</sup> to D<sup>0</sup> is due to a specificity feature of the nouns. On the contrary, in DNCs, the non-movement of the second NP out of VP is due to a non-specific feature of the NPs. If the second NP in DNCs is a specific and definite object, it should move out of VP and raise to some higher functional category. According to Mahajan (1990), the specific objects can move out of VP and structurally be case marked in a functional category but non-specific object should remain within VP and their case-checking takes place within the VP without involving movement. Based on Mahajan's (1990) argument, we can account not only for the movement of specific nouns from N<sup>0</sup> to D<sup>0</sup> in DP but also the non-movement of non-specific (indefinite) objects inside VP.

explain how the remaining NP inside V' can get Nominative, if we take the analysis in (34) over (33) and abandon Structural Case-assignment.

### 5.3.5. Case Theory for Double Nominative Constructions

In the GB theory (Chomsky (1981) of Case-assignment, structural Case is assigned to the subject position in a Spec-head configuration while the object position is assigned Case under government by the verb.

The basic idea assumed in Chomsky (1995) which we are following here is that there is complete symmetry between the subject and the object concerning Case theory. For both positions the relation of NP to the verb is mediated by Agr, a collection of  $\phi$ -features; Case is determined by an element that adjoins to Agr (in English, Tense is responsible for the subject case-marking and Verb for the object case-marking; in Korean the verb is responsible for both the subject and object case-marking). If VP contains only one NP, one of the two AGR elements (Agr<sub>S</sub> or Agr<sub>O</sub>) will be "active". If VP contains two NPs, the two AGR elements (Agr<sub>S</sub> and Agr<sub>O</sub>) will be "active".

In the case of unergative verbs, where only one NP occurs in the Spec position of VP, this NP cannot have any possibility of getting inherent (default) Case since it appears outside V', and therefore it must move somewhere, namely, [Spec,Agr<sub>S</sub>P] for its Case feature to be checked.

In the case of unaccusative verbs such as (1), (2) and (3) where only one AGR is active because the unaccusative verb contains only one NP (object NP) within V', a bare locative NP (if there is any) moves into the active [Spec,AGR<sub>S</sub>P] and checks its Nominative case. The remaining object within V' is inserted from the lexicon with

default case (inherent case) which is Nominative in Korean, resulting in a Double Nominative Construction. I suggest that this inherent or default case need not be checked in a functional category.

In the case of a transitive verb where two AGREements ( $Agr_S$  and  $Agr_O$ ) are active, (because the transitive verb has two arguments), the subject NP moves into [Spec,  $Agr_S$ P] and the object NP raises into [Spec,  $Agr_O$ P], excluding the possibility of the object's getting default case.

### 5.3.5.1. Inherent Case

According to Chomsky (1986b), an inherent Case is a Case assigned by a lexical head to the NP it governs and which it assigns a theta-role to. An inherent Case is assigned at D-structure, in conjunction with theta-role assignment: it is then realised at S-structure.

Suh (1993) claims that the first NP in Korean DNCs moves into the Spec position of Infl (or  $Agr_S$ ) and checks its Nominative against Infl (or  $Agr_S$ ). The second NP is incorporated into the verb and this incorporated NP takes a citation form (default Case), in other words, inherent Case. Xu (1993), adopting Belletti's (1988) proposal in analysing Chinese Possessor Raising, suggests that all classes of verbs can potentially assign inherent (default) Case to object and that some conditions (like the Case filter) filter out unwanted Cases without stipulating that only unaccusative (or ergative) verbs are capable of assigning inherent Case.

A problem in connection with the Case-assignment to the second NP is why it cannot receive structural Accusative Case. The second NP occurs in the object position of the verb. The normal object NP can receive Accusative Case through

Spec-Head agreement in Agr<sub>o</sub>P. In this relation, Burzio (1986) states that all and only the verbs that can assign a theta-role to the subject can assign Accusative Case to the object. I have already pointed out that all the verbs which are related to the Double Nominative Constructions in Korean are unaccusative verbs which have no subject. This fact implies that the unaccusative verb which cannot assign a theta role to the subject cannot assign Accusative Case to the object. Burzio's generalisation may be extended to the Korean Double Nominative Constructions, which occur only in the unaccusative structure.

### 5.3.5.2. The Nature of Inherent Case Marked NPs

Another piece of evidence for inherent Case assignment to the second NP comes from the nature of the second NP. The Nominative Case marker which is attached to the second NP may be deleted and is not compatible with definite or specific meaning:

- (35) a. Seoul-i            pul-i            na-ss-ta.  
           Nom          fire-Nom      break out-Pst-Dec  
           'In Seoul, a fire broke out.'
- b. Seoul-i            pul            na-ss-ta.  
           Nom          fire            break out-Pst-Dec
- c. \* Seoul-i            ku pul-i            na-ss-ta.  
           Nom          the fire-Nom      break out-Pst-Dec
- d. \* Seoul-i            ku pul            na-ss-ta.
- (36) kwudu-ka            kwumeng-i      na-ss-ta.  
       shoes-Nom          hole-Nom        be made-Pst-Dec  
       'A hole was made on the shoes.'
- (37) ce kkot-i            hyangki-ka            nan-ta.  
       that flower-Nom      fragrance-Nom      smell-Dec  
       'That flower smelled sweet.'

- (38) Tom-i        cengsin-i        nak-ass-ta.  
           Nom        mind-Nom        become insane-Pst-Dec  
 ‘Tom was insane.’
- (39) ku il-i        ton-i        dun-ta.  
       that job-Nom    money-Nom    need(ergative)-Dec  
 ‘That job needs some money.’

In (36), (37), (38), and (39), as (35), the Nominative Case marker in the second NP may be deleted, and the definite article ku (the) cannot appear before the second NP. This implies that the object NP marked Nominative is different from the normal object NP marked Accusative and that there is some close and special relationship between the object and the unaccusative verb.

According to Enç (1991), NPs with overt Case morphology are specific, while NPs without Case morphology are non-specific. Belletti (1988) claims that the NPs that are characterised as specific are assigned structural Case, while the non-specific NPs are assigned inherent (partitive) Case. Taken into account the fact that the second NP in Korean DNCs is non-specific and indefinite, the second NP may be said to have inherent Case rather than structural Case, explaining the grammaticality of (35). But if we do not assume the assignment of inherent Case to the second NP, the indefiniteness and non-specificity of (35) cannot be accounted for.

Let us then look at the Definiteness Effect(DE) in English:

- (40) a. The man is in the garden.  
       b. A man is in the garden.  
       c. There is a man in the garden.  
       d. \* There is the man in the garden.

Milsark (1974) notes that NPs with ‘a’, ‘some’, (non-specific determiners) occur in existential sentences while definite (specific) NPs cannot occur in existential sentences. The “there”-construction can also occur with a particular set of verbs, that is, unaccusative verbs under the Unaccusative/Ergative Hypothesis. This inverted subject in “there”-construction is in fact the object of the verb, given the Unaccusative Hypothesis. Hence the DE ultimately is a phenomenon concerning the nature of the object of unaccusative verbs in-situ. It seems that inherent Case always selects an indefinite meaning for the NP that carries it. Inherent Case is the only available Case for the thematic object remaining within VP and this object must be an indefinite or non-specific NP.

If this analysis<sup>4</sup> is correct, it can be extended to Korean: because the Case for the second NP must be inherent and not structural, the second NP cannot carry a definite or specific meaning, and the deletion of Case on the second NP in the DNCs is possible due to the indefiniteness and non-specificity of the second NP (or the object).

In short, I suggest that, in Korean DNCs, the first NP (locative NP) moves into [Spec,AGR<sub>S</sub>P] and checks its Nominative feature and that the second NP gets default or inherent Case in the lexicon and remains within VP. The inherent or default case is a nominative form in Korean. This inherent case need not be checked in a functional category. I suggest that the inherent case marked object in DNCs in Korean is checked by V<sup>0</sup> inside the VP without moving out of the VP.

---

<sup>4</sup> Manzini (p.c.) suggested to me the connection between Definiteness and Case.



### 5.3.5.3. Word Order in DNCs

In the Principles and Parameters theory (Chomsky and Lasnik 1993), word order is determined by the head parameter: languages are head-initial (English) or head-final (Japanese). However, Kayne (1994) offers an alternative to this theory, proposing that according to the LCA<sup>5</sup>, there is only one Spec-Head-Complement word order universally, which I follow in this thesis.

If we adopt a universal Spec-Head-Complement word order for Korean, then we expect the Verb-Object word order in DNCs also. But the actual surface order in Korean DNCs is Object<sup>6</sup>-Verb, as illustrated in (41) below.

- (41) a. John-i     [VP [V' [NP tali-ka] [V<sup>0</sup> kil-ta.]]]  
      Nom            leg-Nom        long-Dec  
      'John has long legs.' Or 'John's legs are long.'
- b. Mary-ka     [VP [V' [NP Peter-ka] [V<sup>0</sup> pokosip-ta.]]]  
      Nom                            Nom        miss-Dec  
      'Mary misses Peter.'
- c. Seoul-i     [VP [V' [NP salam-i] [V<sup>0</sup> manha-ta.]]]  
      Nom                    people-Nom    many-Dec  
      'There are many people in Seoul.'

The adoption of Spec-Head-Complement word order needs an explanation in relation to Korean DNCs.

---

<sup>5</sup> See Chapter 1 of this thesis or Kayne (1994) for discussion of the universal word order Spec-Head-Complement.

<sup>6</sup> The object in DNCs is Nominative case marked.

In consonance with Larson (1988) and Chomsky (1995), I suggest that the Korean VP has a shell structure where the inherent case marked complement (NP) is base-generated in [Spec,VP], and the locative PP (bare locative NP) which is nominative case marked occurs in [Spec, $\upsilon$ P], as in (42).

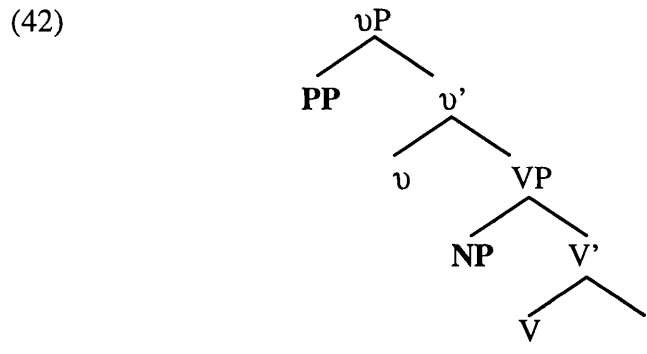

Given this VP-shell structure for Korean DNCs, when a null P appears the bare locative NP in [Spec, $\upsilon$ P] moves to [Spec,Agr<sub>S</sub>P] to check the case features (see 5.3.4 above) before Spell-Out; in contrast, the inherent case marked NP in [Spec,VP] remains in situ due to a non-specificity (indefiniteness) feature, and checks the case features by the verb.

### 5.3.6. The Analysis of Experiencer Constructions

Although so far only locative existentials have been discussed, another type of unaccusative verbs that display the DNC are Experiencer verbs.

- (43) a. *Peter-ka holangi-ka mwusep-ta.*  
 Nom tiger-Nom be afraid of-Dec  
 ‘Peter is afraid of a tiger.’

- b. *Mary-ka* Jane-i silh-ta.  
 Nom Nom dislike-Dec  
 ‘Mary dislikes Jane.’

The italicised *Peter-ka* and *Mary-ka* in (43) are experiencers. Belletti and Rizzi (1988) distinguish between subject Experiencers and object Experiencers. The Experiencer, whatever it may be, is projected to a higher position than the theme.

Pesetsky (1992) presents three semantic roles instead of Agent and Theme: Causer, Experiencer, and Target (or Subject -Matter):

(44) The highest argument is mapped onto the highest D-structure position in its clause: Causer> Experiencer>Target/Subject-Matter:

- (i) Anger---> [<sub>VP</sub> Causer [<sub>V</sub> anger [Experiencer]]]
- (ii) Love ---> [<sub>VP</sub> Experiencer [<sub>V</sub> love [Target]]]

The semantic feature of the first dative NP in (3) is that of “Experiencer”. The promotion of Experiencer NPs into [Spec,IP] ([Spec,AgrsP]) can be explained in accordance with Pesetsky’s (44).

In Italian, the underlying object of an unaccusative verb may remain in the object position at S-structure without raising to a higher position. In Korean an experiencer NP is promoted to a higher position (note that an experiencer NP is higher than any Theme NP), the object NP can remain within VP and get default Case in the lexicon. In this connection, one problem arises: in the presence of an Experiencer role, the DNCs come to have two arguments, an Experiencer NP and a Theme (object) NP.

This means that the DNC clause may have two AGR elements, or Agr<sub>S</sub>P and Agr<sub>O</sub>P like a transitive clause. I leave this discussion for the future research.

### 5.3.7. The Analysis of Possessive Constructions

Let us begin with the following examples:

- (45) a. Mary-uy/ka                      phal-i                      khu-ta.  
                     Gen/Nom                      arm-Nom                      big-Dec  
                     ‘Mary’s arm is big.’
- b. Banana -uy/ka                      kkepcil-i                      kka-ci-ess-ta.  
                     Gen/Nom                      skin-Nom                      peel-Psv-Pst-Dec  
                     ‘The banana was peeled.’

In general the first NPs (the possessor or the whole NPs) in possessive constructions agree in Case with the second NPs (the possessed or the part NPs). One approach to this Case-marking, as mentioned before, is to assume that the verb assigns its Case to a single NP, and the other NP(s) gets Case under Case-agreement between the first NP and other NP(s). The other approach, which I adopt here, is Direct Case-marking. But differently from the previous analyses (see Maling and Kim (1992) and Suh (1993), among others) in which the first NP marked Nominative is derived from the possessive position, we argue that the first possessor NP is derived from the locative dative position.

According to Freeze (1992), a possessor is a semantic location. The ’s (genitive) marking of a possessor and the P of a P-marked location subject are equivalent. His idea is that when a P-marked locative (or dative) phrase and a theme NP are in the relation of possession, the locative phrase may move into the ’s (genitive) marking,



Adopting these ideas, I claim that Korean possessive constructions in Double Nominative form are derived from the locative. In Korean also, when the locative NP and the theme NP are in the relation of possession, the locative (or dative) may move into the [Spec,Agr<sub>S</sub>P] as in (48b) (in the case of Double Nominative Construction), or it may move into the *'s genitive position* as in (48c) (in the case of possessive construction), or the *'Have' construction* can arise, as in (48d) below.

- (48) a. John-eke      cha-ka      iss-ta.  
                     Dat      car-Nom      be-Dec  
                     ‘(Lit.) A car is to John.’
- b. [Agr<sub>SP</sub> John-i      [VP cha-ka      iss-ta.]]  
                                 Nom      car-Nom      be-Dec  
                     ‘John has a car.’
- c. John-uy      cha-ka      iss-ta.  
                     Gen car-Nom      be-Dec  
                     ‘There is a car of John’s.’
- d. John-i              cha-lul              kasyess-ta.  
                     Nom      car-Acc              have-Dec  
                     ‘John has a car,’

### 5.3.7.1. Evidence from Honorification

The following argument supports our claim that the first NP in the Korean DNCs is generated in locative position and then moves into the subject position and checks its Nominative Case feature. First, let us take a look at a DNC:

- (49) a. John-i              halapeci-ka              mwusep-ta/ \*mwusewu-si-ta.  
                     Nom      grandfather-Nom              afraid-Dec/ \* afraid-Hon-Dec  
                     ‘John is afraid of his grandfather.’







in (1) above while the DACs are possible only when an inalienable possessive relationship holds between the first Accusative nominal and the second Accusative nominal, as in (53) and (54) (examples from K.-Y. Choi (1991)).

(53) a. \* John-i Mary-lul kangaci-lul pwutcap-ass-ta.  
Nom Acc dog-Acc hold-Pst-Dec  
'John held Mary's puppy.'

b. \* John-i Mary-lul chayksang-ul chi-ess-ta.  
Nom Acc desk-Acc hit-Pst-Dec  
'John hit Mary's desk.'

(54) a. John-i Mary-lul son-lul cap-ess-ta.  
Nom Acc hand-Acc catch-Pst-Dec  
'John caught Mary's hand.'

b. John-i [Mary-uy son]-lul cap-ess-ta.  
Nom Gen hand-Acc catch-Pst-Dec  
'John caught Mary's hand.'

With respect to the structure of DACs, there are two approaches. The first approach assumes that the possessor NP and the possessed NP forms a single constituent<sup>7</sup> (M.-Y. Kang 1987). The other approach argues that the possessor NP and the possessed NP are base-generated independently of each other<sup>8</sup>. In this thesis, following Maling

---

<sup>7</sup> That is, (54a) has the same D-Structure as its Gen-Acc counterpart in (54b). Accusative Case is assigned to the possessed NP, and then the possessor NP is Case-marked under Case-agreement between the possessor NP and the possessed NP. Or alternatively Accusative Case which is assigned to the possessed NP percolates to the possessor NP.

<sup>8</sup> In Section 5.3. above, I argued that the possessor NP and the possessed NP in DNCs also are independently base-generated with each other.

and Kim (1992) and J.-S. Lee (1992), I claim that the possessor NP and the possessed NP in DACs are inserted from the lexicon independently of each other.

According to M.-Y. Kang (1987), the possessor NP is the direct object of the verb, as seen in (55). The following examples in (55) are reproduced from J.-S. Lee (1992).

- (55) a. John-i            Mary-lul    son-ul    cap-ess-ta.  
           Nom            Acc    hand-Acc    catch-Pst-Dec  
           ‘John caught Mary’s hand.’
- b. Mary-ka    John-eykey    son-ul    cap-hi-ess-ta. ----- Passivization  
           Nom            by            hand-Acc    catch-Psv-Pst-Dec  
           ‘Mary was caught by the hand by John.’
- c. \* Son-i            John-eykey    Mary-lul    cap-hi-ess-ta. ----- Passivization  
           hand-Nom            by            Acc    catch-Psv-Pst-Dec  
           ‘Hand was caught Mary by John.’
- d. [Mary-uy son]-i            John-eykey    cap-hi-ess-ta. ----- Passivization  
           Gen hand-Nom            by            catch-Psv-Pst-Dec  
           Mary’s hand was caught by John.’

M.-Y. Kang (1987) argues that the possessor NP Mary can be passivized as in (55b) but the possessed NP cannot as in (55c). Notice that the whole genitive phrase Mary-uy son ‘Mary’s hand’ can be passivized as in (55d). This indicates that the possessor NP functions as an object of the verb but the possessed NP does not.

Even though the possessed NP is not an object of the verb, the possessed NP is an argument of the verb. Maling and Kim (1992) argue that the possessed NP is the argument subcategorised for by the verb, like the possessor NP (examples from J.-S. Lee (1992)).

- (56) a. John-i Mary-lul \*(sonthop-ul) kkak-ess-ta.  
 Nom Acc fingernail-Acc clip-Pst-Dec  
 'John clipped Mary's fingernail.'
- b. John-i Mary-lul \*(meli-lul) cal-ess-ta.  
 Nom Acc hair-Acc cut-Pst-Dec  
 'John cut Mary's hair.'

The sentences in (56) without the possessed NPs are ungrammatical. The observation shows that the possessed NPs in (56) are subcategorised for by the verb, and therefore they must be an argument of the verb independently of the possessor NP.

J.-S. Lee (1992) claims that the possessed NP is a locative PP argument of the verb. He contends that the possessed NP in (55) refers to a location in the body, and that the possessor receives a Theme theta role and the possessed NP a Location role, based on the following examples in (57).

- (57) a. John-i Mary-lul eti /\*mwues-ul cap-ess-ni ?  
 Nom Acc where'\* what-Acc catch-Pst-Q  
 'Which part of Mary did John catch ?'
- b. John-i Mary-lul eti /\*mwues-ul kkak-ess-ni ?  
 Nom Acc where'\* what-Acc clip-Pst-Q  
 'Which part of Mary did John clip ?'

The fact that the possessed NP can be replaced by *eti* 'where', but not by *mwues* 'what' indicates that the possessed NP is a locative element. The D-Structures for (54a) and (54b) then will be (58a) and (58b), respectively.

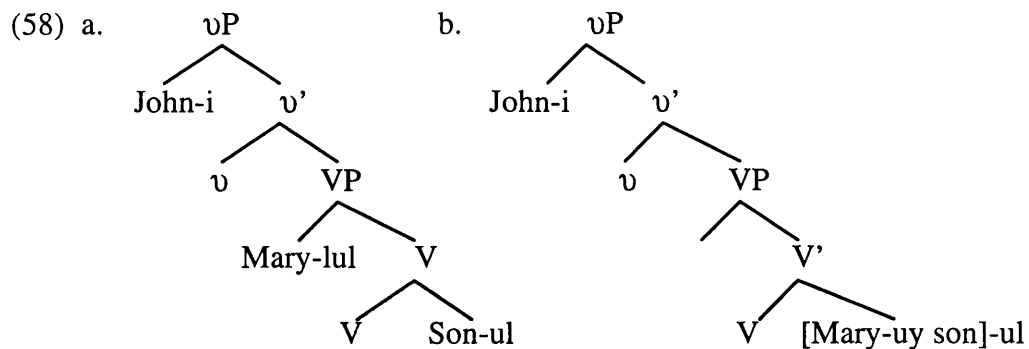

Now we can ask: how is the Double Accusative Case marking done ? Based on the minimalist framework which allows multiple movement to a Spec position<sup>9</sup>, I propose that in DACs the second NP (possessed NP) moves into [Spec,Agr<sub>o</sub>P] to check the Accusative Case and the first NP (possessor NP) also moves to another spec position of the same Agr<sub>o</sub>P to check the Accusative case, as illustrated in (59).

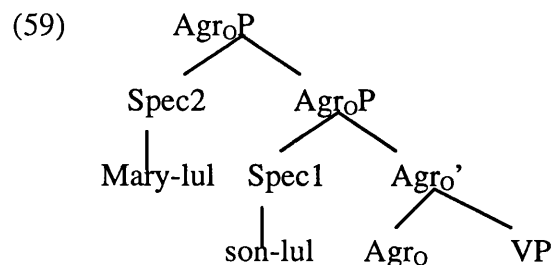

According to the notion of equidistance in Section 1.2.4 of this thesis, Spec2 and Spec1 of Agr<sub>o</sub>P are equidistant from  $\gamma$ . Remember that if the verb in (58a) moves to Agr<sub>o</sub> in (59) by adjunction, [Spec1,Agr<sub>o</sub>P] and [Spec2,Agr<sub>o</sub>P] in (59) are all in the same minimal domain, and they are all equidistant from  $\gamma$ .

In 5.3.5 above, I argued that the DNCs do not make use of multiple Spec positions for double Nominative case-marking. In contrast, here I argue that the

<sup>9</sup> See 1.2.8 in Chapter 1 for discussion of multiple Specs.

DACs exploit multiple spec positions for double Accusative case-marking. What is the difference between DNCs and DACs with respect to case-marking ? As seen in 5.3.5, I showed that the second NP in DNCs is indefinite and non-specific and therefore remains within the VP being inherently case-marked by the verb. But the DACs are different from the DNCs with respect to the case-assignment of the possessed NP. In DNCs the second NP can appear without the Nominative case marker *i/ka* showing indefiniteness, as shown in (35) above. However, the second NP in DACs must have the Accusative case marker *ul/lul*, as in (60). (54a) is repeated here as (60).

- (60)        John-i     Mary-lul    son-\*(ul)    cap-ess-ta.  
                   Nom            Acc   hand-Acc   catch-Pst-Dec  
                   ‘John   caught Mary’s hand.’

I assume that the possessed NP (the second NP) in DACs is structurally case marked unlike in DNCs. Notice that if the second NP in DACs appears without the Accusative Case marker overtly, the derivation would result in an ungrammaticality. So the second NP in DACs must move to another Spec position of Agr<sub>o</sub>P to check the structural case features, as illustrated in (59).

In sum, the possessor NP and the possessed NP in DACs are base-generated in different positions independently of each other, just as in DNCs. The difference between DNCs and DACs concerning the case-marking is that the second NP in DNCs is inherently case marked within the VP while the second NP in DACs is structurally case marked in [Spec, Agr<sub>o</sub>P] just like the first NP.

## BIBLIOGRAPHY

- Abney, P. Steven. 1987. *The English NP in its Sentential Aspect*. Ph.D. dissertation, MIT.
- Ahn, Hee-Don. 1988. Preliminary Remarks on Korean NP. In *Proceedings of International Conference on Korean Linguistics*, Seoul.
- Aoun, Joseph, and D. Sportiche. 1983. On the Formal Theory of Government. *The Linguistic Review* 2.
- Bak, Sung-Yun. 1981. *Studies in Korean Syntax: Ellipsis, Topic and Relative Constructions*. Ph.D. dissertation, University of Hawaii.
- Bak, Sung-Yun. 1984. Why not a Topic in a Relative Clause ? *Language Research* 20.
- Baker, M. 1988. *Incorporation: A theory of Grammatical Function Changing*. Chicago: University of Chicago Press.
- Baltin, M. 1982. A landing site theory of movement rules. *Linguistic Inquiry* 13.
- Belletti, Adriana and Luigi Rizzi. 1988. Psyche-verbs and theta-Theory. *Natural Language and Linguistic Theory* 6.
- Belletti, Adriana. 1988. The Case of Unaccusatives. *Linguistic Inquiry* 19.
- Bhattacharya, Tanmoy. 1996. *The Structure of the Bangla DP*. Ms., University College London.
- Bianchi, Valentina. 1995. *Consequences of Antisymmetry for the syntax of headed relative clauses*. Ph.D. dissertation, Scuola Normale Superiore, Pisa.
- Borsley, Robert. 1996. *Relative Clauses and the Theory of Phrase Structure*. Ms., University of Wales, Bangor.
- Bowers, S. John. 1974. *On restrictive and non-restrictive relative clauses*. Ms., Cornell University.
- Brame, Michael. 1976. *Conjectures and refutations in syntax and semantics*. New York: Elsevier North-Holland.
- Brody, Michael. 1995. *Lexico-Logical Form*. Cambridge, Mass.: MIT Press.
- Burzio, L. 1986. *Italian Syntax: A Government-Binding Approach*. Dordrecht: Reidel.

- Carlson, N. Glen. 1977. A unified analysis of the English bare plural. *Linguistics and Philosophy* 8.
- Carstens, V. 1991. The Morphology and syntax of determiner Phrases in Kiswahili. Ph.D. dissertation, UCLA.
- Choe, Hyun-Sook. 1988. Restructuring Parameters and Complex Predicates --- A Transformational Approach. Ph.D. Dissertation, MIT.
- Choi, Ki-Yong. 1991. Double Accusatives in Part-whole Constructions in Korean. *Journal of the Linguistic Society of Korea* 13.
- Chomsky, Noam. 1977. On Wh-movement. In *Formal Syntax*, edited by P. Culicover, T. Wasow, and A. Akmajian. New York: Academic Press.
- Chomsky, Noam. 1981. *Lectures on Government and Binding*. Dordrecht: Foris.
- Chomsky, Noam. 1982. *Some Concepts and Consequences of the Theory of Government and Binding*. Cambridge, Mass.: MIT Press.
- Chomsky, Noam. 1986a. *Barriers*. Cambridge, Mass.: MIT Press.
- Chomsky, Noam. 1986b. *Knowledge of Language: Its Nature, Origin, and Use*. New York: Praeger.
- Chomsky, Noam. 1995. *The Minimalist Program*. Cambridge, Mass.: MIT Press.
- Chomsky, Noam, and Howard Lasnik. 1993. Principles and Parameters Theory. In J. Jacobs, A. Von Stechow, W. Sternefeld and T. Vennemann (eds.), *Syntax: An International handbook of Contemporary Research*. Berlin: de Gruyter.
- Cinque, Guglielmo. 1980. On Extraction from NPs in Italian. *Journal of Italian Linguistics* 5.
- Cinque, Guglielmo. 1990a. Ergative Adjectives and the Lexicalist Hypothesis. *Natural Language and Linguistic Theory* 8.
- Cinque, Guglielmo. 1990b. Agreement and Head-to-Head Movement in the Romance Noun Phrase. Paper presented at the XXst Linguistic Symposium on Romance Languages, University of Ottawa.
- Cinque, Guglielmo. 1992. Functional Projections and N movement within the DP. Talk presented at GLOW 1992.
- Cinque, Guglielmo. 1993. On the Evidence for Partial N Movement in the Romance DP. Ms., University of Venice.
- Cinque, Guglielmo. 1995. Sintassi del participio e struttura della frase. Presented at the Conference, the Scuola Normale Superiore, Pisa.

- Cole, Peter. 1987. Internally Headed Relative Clauses. *Natural Language and Linguistic Theory* 5.
- Comrie, Bernard. 1976. *Aspect*. Cambridge: Cambridge University Press.
- Comrie, Bernard. 1989. *Language Universals and Linguistic Typology: Syntax and Morphology*. Oxford: Basil Blackwell.
- Cook, V. J. and Mark Newson. 1997. *Chomsky's Universal Grammar: An Introduction*, 2nd edition. Oxford: Basil Blackwell.
- Coopmans, P. 1988. Where stylistic and syntactic processes meet: inversion in English. In *Dutch working papers in English language and linguistics 1*.
- Delsing, Lars Olaf. 1988. The Scandinavian noun phrase. In *Working Papers in Scandinavian syntax 42*.
- Dryer, S. Matthew. 1994. Internally Headed Relative Clauses in Japanese are Internally Headed. Ms., SUNY at Buffalo.
- Enç, M. 1991. The Semantics of Specificity. *Linguistic Inquiry* 22.
- Fabb, Nigel. 1990. The Difference between English Restrictive and Appositive Clauses. *Journal of Linguistics* 26.
- Fillmore, C. 1968. The case for case. In *Universals in linguistic theory*, edited by Emmon Bach and Robert Harms. New York: Holt, Reinhart, and Winston.
- Freeze, R. 1992. Existentials and other Locatives. *Language* 68.
- Fukui, Naomi, and Margaret, Speas, 1986. Specifiers and Projections. In *MIT Working Papers in Linguistics 8*. Department of Linguistics and Philosophy, MIT.
- Fukui, Naomi. 1986. A Theory of Category Projections and its Applications. Ph.D. dissertations, MIT.
- Gerds, D. and Cheong Youn. 1989. Non-Nominative Subjects in Korean. In *Harvard Studies in Korean Linguistics. 3*. Seoul: Hanshin Publishing Co.
- Grimshaw, J. B. 1986. Noun, Arguments, and Adjuncts. Ms., Brandeis University, Waltham, Massachusetts.
- Haider, H. 1993. Detached Clauses - the Later the deeper. Ms., University of Stuttgart.
- Han, Hak-Sung. 1987. The Configurational Structure of the Korean Language. Ph.D. dissertation, University of Texas at Austin.



- Heycock, C. 1993. Syntactic Predication in Japanese. *Journal of East Asian Linguistics* 2.
- Hoekstra, Eric. 1992. X-bar Theory and Licensing Mechanisms. *The Linguistic Review* 8.
- Hoekstra, T. and R. Mulder. 1990. Unergatives as copular verbs; Locational and Existential predication. *The Linguistic Review* 7.
- Jackendoff, S. Ray. 1977. *X-Bar Syntax*. Cambridge, Mass.: MIT Press.
- Jaggar, J. Philip. 1997. Restrictive and Non-restrictive Relative Clauses in Hausa. Ms., SOAS, London.
- Jhang, Sea-Eun. 1991. Internally Headed Relative Clauses in Korean. M.A. Thesis, State University of New York at Buffalo.
- Jhang, Sea-Eun. 1994. Headed Nominalizations in Korean: Relative Clauses, Clefts, and Comparatives. Ph.D. dissertation, Simon Fraser University.
- Jonas, D., and J. Bobaljik. 1993. Specs for subjects: The role of TP in Icelandic. In *MIT Working Papers in Linguistics 18: Papers on Case and agreement I*. (eds) by Bobaljik, J., and C. Philips. Department of Linguistics and Philosophy, MIT.
- Johnson, D. and S. Lappin. 1977. A critique of the minimalist program, *Linguistics and Philosophy* 20, pp. 273-333.
- Kang, Myung-Yoon. 1987. Possessor Raising in Korean. In *Harvard Studies in Korean Linguistics II*. Seoul: Hanshin Publishing Co.
- Kang, Young-Se. 1986. Korean Syntax and Universal Grammar. Ph.D. dissertation, Harvard University.
- Kayne, S. Richard. 1994. *The Antisymmetry of Syntax*. Cambridge, Mass.: MIT Press.
- Keenan, L. Edward. 1985. Relative Clauses. In *Language Typology and Syntactic Description. Vol. 2: Complex Constructions*, edited by Timothy Shopen. Cambridge: Cambridge University Press.
- Kim, Alan Hyun-Oak. 1995. Word order at Noun Phrase level in Japanese-Quantifier Constructions and discourse functions. In *Word order in discourse*, edited by Pamela Downing and Michael Noonan. Amsterdam: John Benjamins.
- Kim, Yang-Soon. 1988. Licensing principles and Phrase Structure. Ph.D. dissertation, University of Wisconsin-Madison.
- Kim, Young-Kook. 1996. On the Structure of Relative Clauses. In *Proceedings of 1996 Seoul International Conference on Generative Grammar: Morphosyntax in Generative Grammar*. Seoul: Hankuk Publishing Co.

- Koopman, H, and D. Sportiche. 1982. Variables and Bijection principle. *The Linguistic Review* 2.
- Kuno, Susumu. 1971. The position of locatives in existential sentences. *Linguistic Inquiry* 2.
- Kuno, Susumu. 1972. Pronominalization and Reflexivization, and Direct Discourse. *Linguistic Inquiry* 3.
- Kuno, Susumu. 1973. *The Structure of Japanese*. Cambridge, Mass.: MIT Press.
- Kuroda, S. Y. 1985. Whether you agree or not. Ms., University of California at San Diego.
- Larson, K. Richard. 1988. On the Double Object Construction. *Linguistic Inquiry* 19.
- Lasnik, Howard and Mamoru, Saito. 1984. On the nature of proper government. *Linguistic Inquiry* 15.
- Lee, Chungmin. 1973. Abstract Syntax and Korean With Reference to English. Ph.D. dissertation, Indiana University.
- Lee, Hyo-Sang. 1991. Tense, Aspect, and Modality: a Discourse-Pragmatic Analysis of Verbal Affixes in Korean from a Typological Perspective. Ph.D. dissertation, UCLA.
- Lee, Jeong-Shik. 1992. Partitive Case on the Body-Part NP. In *Papers from the 4th student Conference in Linguistics*, Ohio State University.
- Lee, Kwee-Ock, B. Lust, and John Whitman. 1990. On Functional Categories in Korean: A study of the first language acquisition of Korean relative clauses. In *Papers from 7th Int'l Conference on Korean Linguistics*. Toronto: University of Toronto Press.
- Lee, Kwee-Ock. 1991. On the first language acquisition of relative clauses in Korean: The universal structure of COMP. Ph.D. dissertation, Cornell University.
- Lee, Sun-Woo. 1983. Syntax of Some Nominal Constructions in Korean. Ph.D. dissertation, University of Wisconsin-Madison.
- Levin, L. 1985. Operations on lexical forms: unaccusative rules in Germanic languages. Ph.D. dissertation, MIT.
- Longobardi, Giuseppe. 1990. Evidence for the structure of Determiner Phrases, and N-movement in the syntax and LF. *Glow Newsletter*.

- Longobardi, Giuseppe. 1991. In Defence of the Correspondence Hypothesis. In J. Huang and R. May, eds., *Logical Structure and Linguistic Structure*. Dordrecht: Kluwer Academic Publishing.
- Lyons, J. 1967. A note on possessive, existential, and locative sentences. *Foundations of Language* 3.
- Mahajan, A. 1990. The A/A-bar Distinction and Movement theory. Ph.D. dissertation, MIT.
- Maling, Joan. 1989. Adverbial and Structural Case in Korean. In *Harvard Studies in Korean linguistics III*. Seoul: Hanshin Publishing Co.
- Maling, Joan and Soo-Won Kim. 1992. Case assignment in the inalienable possession construction in Korean. *Journal of East Asian Linguistics* 1.
- Manzini, M. Rita. 1992. *Locality: A theory and some of its empirical consequences*. Cambridge, Mass.: MIT Press.
- Manzini, M. Rita. 1994a. Locality, Minimalism and Parasitic gaps. *Linguistic Inquiry* 25.
- Manzini, M. Rita. 1994b. Adjuncts and the theory phrase structure. Presented at the Tilburg Conference on Rightward Movement.
- McCawley, D. James. 1981. The Syntax and Semantics of English Relative Clauses. *Lingua* 53.
- McConvell, Patrick. 1973. Cleft sentences in Hausa: A syntactic study of focus. Ph.D. dissertation, University of London.
- Milsark, G. 1974. Existential Sentences in English. Ph.D. dissertation, MIT.
- Moon, Gui-Soon. 1987. The distribution of pro in Korean and the theoretical implications. Ms., University of Texas at Austin.
- Parsons, F. W. 1981. *Writings on Hausa Grammar: The Collected Papers of F. W. Parsons*. Ann Arbor, Michigan: UMI Books on Demand.
- Partee, Barbara. 1975. Montague Grammar and Transformational Grammar. *Linguistic Inquiry* 6.
- Perlmutter, D. 1978. Impersonal passives and the Unaccusative hypotheses. In *Proceedings of the 4th Berkeley Linguistics Society*.
- Pesetsky, D. 1992. *Zero Syntax Volume I : Experiencers and Cascades, Version 2.0*. Cambridge, Mass.: MIT press.

- Picallo, C. 1990. Nominals and nominalization in Catalan. Ms., Universitat Autònoma de Barcelona.
- Pollock, Jean-Yves. 1989. Verb movement, Universal Grammar, and the Structure of IP. *Linguistic Inquiry* 20.
- Ritter, Elizabeth. 1988. A head-movement approach to construct-state Noun Phrases. *Linguistics* 26.
- Ritter, Elizabeth. 1990. Two functional categories in Noun Phrases: Evidence from Modern Hebrew. Ms., UQAM.
- Rizzi, Luigi. 1982. *Issues in Italian Syntax*. Dordrecht: Foris.
- Rizzi, Luigi. 1990. *Relativized Minimality*. Cambridge, Mass.: MIT Press.
- Ross, John. 1967. Constraints on variables in syntax. Ph.D. dissertation, MIT.
- Saito, Mamoru. 1985. Some Asymmetries in Japanese and their Theoretical Implications. Ph.D. dissertation, MIT.
- Schachter, Paul. 1973. Focus and relativization. *Language* 49.
- Schuh, G. Russell. 1985. Hausa tense/aspect/mood (TAM) system. Ms., UCLA.
- Shibatani, M. 1977. Relational Grammar and Korean Syntax. *Language Research* 12.
- Shin, Sang-Chul. 1987. A Unifying Theory of Topic, Conditional, and Relative Constructions in Korean: A case for archimorpheme cross syntactic categories. Ph.D. dissertation, The University of Michigan.
- Smith, Carlota. 1991. *The Parameter of Aspect*. Dordrecht: Kluwer Academic Publishing.
- Stockwell, R., P. Schachter and B. Partee. 1973. *The major syntactic structures of English*. New York: Holt, Reinhart, and Winston.
- Stroik, S. Thomas. 1994. Saturation, Predication, and the DP-Hypothesis. *Linguistic Analysis* 24.
- Suh, S-K. 1993. The syntax of Korean Multiple Nominative Constructions. In *University of Maryland Working Papers in Linguistics*.
- Szabolcsi, A. 1981. The possessive construction in Hungarian: A configurational category in a non-configurational language. *Acta Linguistica Academiae Scientiarum Hungaricae* 31.
- Szabolcsi, A. 1983. The possessor that ran away from home. *Linguistic Review* 3.

- Szabolcsi, A. 1987. Functional categories in the Noun Phrase. In I. Nenesi, (edited) *Approaches to Hungarian Vol. 2*.
- Szabolcsi, A. 1990. Noun Phrases and Clauses: Is DP analogous to IP or CP ? To appear in J. Payne (ed.), *Proceedings of the Manchester Colloquium on Noun Phrase*.
- Taraldsen, Tarald, 1990. D-projections and N-projections in Norwegian. In *Grammar in progress*, edited by Marina Nesper and Joan Mascaró. Dordrecht: Foris.
- Tateishi, K. 1988. On the Universality of X-bar Theory: the Case of Japanese. In Hagit Borer (ed.), *Proceedings of WCCFL 7*.
- Ura, H. 1994. Varieties of raising and the feature-based phrase structure theory. In *MIT Occasional Papers in Linguistics 7*. Department of Linguistics and Philosophy, MIT.
- Valois, Daniel. 1991. The internal syntax of DP. Ph.D. dissertation, UCLA.
- Vergnaud, Jean-Roger. 1975. La reduction du noeud S dans les relatives et les comparatives. Rapport de Recherches, laboratoire d'Automatique Documentaire et Linguistique, University of Paris 7 and University of Paris 8.
- Watanabe, Akira. 1992. Subjacency and S-Structure Movement of WH-in-situ. *Journal of East Asian Linguistics 1*.
- Whitman, John. 1981. The Internal Structure of NP in Verb-Final Languages. In *Papers from the 17th Regional Meeting*, Chicago Linguistic Society.
- Whitman, John. 1989. Topic, Modality, and IP Structure. In *Harvard Studies in Korean Linguistics VI*. Seoul: Hanshin Publishing Co.
- Williams, E. S. 1994. *Thematic Structure in Syntax*. Cambridge, Mass.: MIT Press.
- Wilson, William. 1963. Relative Constructions in Dagbani. *Journal of African Languages*.
- Xu, J. 1993. Possessor Raising in Chinese Passive and Ergative Constructions. In *University of Maryland Working Papers in Linguistics*.
- Yang, Byong-Seon. 1994. Morphosyntactic Phenomena of Korean in Role and Reference Grammar: Psyche-verb Constructions, Inflectional Verb Morphemes, Complex sentences, and Relative Clauses. Ph.D. dissertation, State University of New York at Buffalo.
- Yang, Dong-Whee. 1973. Topicalization and Relativization in Korean. Ph.D. dissertation, Indiana University.
- Yang, Dong-Whee. 1975. *Topicalization and Relativization*. Seoul: Pan Korea Book.

Yang, Dong-Whee. 1995. Lectures on the Minimalist Program, In *Proceedings of International Conference on Korean Linguistics*, Seoul.

Yang, In-Seok. 1972. Korean Syntax: Case markers, Delimiters, Complementation and Relativization. Ph.D. dissertation, University of Hawaii.

Yoon, Hang-Jin. 1991. Functional Categories and Complementation: In English, Korean and Turkish. Ph.D. dissertation, University of Wisconsin-Madison.

Yoon, Jong-Yurl. 1990. Korean Syntax and Generalized X-bar Theory. Ph.D. dissertation, University of Texas at Austin.

Yoon, Man-Guen. 1996. *Generative Syntax* [in Korean]. Seoul: Hankuk Publishing Co.