

**Department of Civil, Environmental and
Geomatic Engineering**



Proportioning of self-compacting concrete – the UCL method

P Domone

November 2009

This document sets out a procedure of the proportioning of self-compacting concrete (SCC) mixes which is suitable for use by an experienced concrete technologist who may not be familiar with SCC. It requires access to a laboratory with reasonable range of equipment for standard testing of fresh concrete, but not containing techniques for more sophisticated testing, such as mortar or concrete rheology. It is based on work carried out in a succession of studies at UCL.

© Peter Domone 2010

Contents

1. Introduction.....	2
2. General considerations	2
3. Concrete requirements.....	2
4. General considerations for mix proportioning.....	4
5 The UCL method of proportioning of SCC	5
5.1 Test methods and equipment	5
5.2 Procedure	5
1. Specified concrete properties.....	5
2. Materials data.....	6
3. Coarse aggregate content.....	6
4. Fine aggregate content	6
5. Paste volume and composition	6
6. Trial mixes on concrete	7
Appendix A Tests for mortar.....	15
A1. Spread.....	15
A2. V-funnel	17
Appendix B Tests for concrete	19
B1. Slump flow and flow-time T_{500}	19
B2. V-funnel flow-time.....	21
B3. J-Ring	23
B4. L-Box.....	26
B5. Segregation - Sieve stability.....	28
References	30

1. Introduction

There have been many mix design approaches and procedures proposed and used in the relatively short history of self-compacting concrete. This is not surprising as mix proportioning is clearly an essential first stage for either research programmes or practical applications. These have been of widely varying complexity and therefore ease of use, but taken together have resulted in a comprehensive understanding of the factors affecting the concrete properties. It is not the intention of this document to review or compare these - this has been done elsewhere [1].

It is however, worth noting that the development and use of self-compacting concrete in the last two decades has led to a considerable body of knowledge of proportions that have achieved many combinations of required properties. Perhaps the simplest approach to proportioning is therefore to develop a mix or mixes for a specific application by starting with a potential mix based on these previous experiences and then proceed on a trial-and-error basis. Some data which are useful in this respect is given in the first part of the report, after some general considerations of properties and specifications. However, whilst such an approach may be successful in some instances, it is preferable to proceed on a more rational, but not necessarily complex, basis, and that is the intention of the method proposed in the second part of this document.

2. General considerations

Combining the constituent materials in the optimum proportions to give concrete with the required combination of fresh and hardened properties for a particular application is clearly an essential part of the SCC production process.

Mix proportioning (or mix design) must start with the definition or selection of the required properties. The fresh properties are normally defined by values of measurements from appropriate tests selected to measure the key properties of interest, and a number of tests have been standardised. It is therefore useful to start by considering the level and ranges of properties that may be required and how they have been classified.

3. Concrete requirements

It is widely accepted that successful SCC needs a combination of three key distinct properties:

1. **Filling ability** (also called unconfined flowability): the ability to flow into and completely fill all spaces within the formwork under its own weight. This property is a combination of total flow capacity and flow rate.
2. **Passing ability** (also called confined flowability): the ability to flow through and around confined spaces between steel reinforcing bars without segregation or blocking.
3. **Segregation resistance** (also called stability): the ability to remain homogeneous both during transport and placing (i.e. in dynamic conditions) and after placing (i.e. in static conditions).

In rheological terms the first and third properties require a combination of a low yield stress and a moderate plastic viscosity.

When considering production, supply and quality control issues we should add the properties of **robustness**, which is the capacity of a mix to tolerate the changes and variations in materials and procedures that are inevitable with production on any significant scale, and

consistence retention (sometimes called open-time) which is the ability of the mix to retain its self-compacting properties until placing.

Different levels and combinations of these properties are required for different applications; for example:

- the required passing ability will depend on the bar spacing in the member being filled;
- the required degree of segregation resistance will depend on the transport and placing methods (pump, skip etc.) and the size (particularly the height) of the space being filled.

An important first step in mix design and development is therefore the definition of the required properties for the specific application in terms of values measured by common or standardized tests. Figure 1 shows examples of different combinations of flow capacity (as measured by the slump-flow test*, which gives a good indication of yield stress) and flow rate (as measured by the V-funnel test, which gives a good indication of plastic viscosity) for various applications that has been given by Walraven [2].

The classifications proposed by the EFNARC European project group in 2005 [3] (Table 1) gives sets of classes for slump flow, viscosity, passing ability and segregation resistance (or stability) based on the values obtained with the tests as specified in the European standards [4, 5, 6, 7]. The accompanying guidelines state that:

- slump flow will normally be specified for all SCC;
- the viscosity may be important where good surface finish is required or the reinforcement is very congested but need not be a requirement in other cases;
- passing ability is not a requirement if there is little or no reinforcement;
- in most cases class SR1 segregation resistance will be adequate.

The EFNARC passing ability classes are based on L-box measurements. However, the alternative J-ring test is also included in the European standards [8] and results from the Testing-SCC project [9] of the step-heights corresponding to the L-box height ratios have been added to Table 1.

The corresponding EFNARC classes for the suggested properties have been included in figure 1 and it is interesting to note that mixes with a flow capacity lower than that of the minimum EFNARC slump flow class (SF1) are appropriate for some situations. Indeed, the American Concrete Institute [10] defines three slump flow targets: less 550 mm, 550 to 650 mm and greater than 650mm, but they do note that mixes with a slump flow of less than 550 mm may require minor vibration. However, an analysis of 68 case studies of worldwide uses of SCC in the period 1993 – 2003 [11] showed that nearly 50% of the applications used concrete with slump flows in EFNARC class SF1, and a further 35% with slump flows in EFNARC class SF2 (figure 2)

* detailed descriptions of all test methods are given in the Appendices

4. General considerations for mix proportioning

The early development of SCC in Japan established the essential criteria for achieving the three key properties [12].

- a low water/cement (or water/powder) ratio with high doses of superplasticizer to achieve high flow capacity without instability or bleeding;
- a paste content sufficient to overfill all the voids in aggregate skeleton to the extent that each particle is surrounded by an adequate lubricating layer of paste, thus reducing the frequency of contact and collision between the aggregate particles during flow;
- a sufficiently low coarse aggregate content to avoid particle bridging and hence blocking of flow when the concrete passes through confined spaces.

Such mixes are sometimes called *powder type mixes*. An early alternative is to achieve sufficient stability at higher water/powder ratios by incorporating a viscosity modifying agent (VMA), thus producing a *viscosity-agent type SCC*, analogous to underwater concrete. In practice, such mixes have not proved popular and an intermediate *combined type SCC* is more often used. In this, a superplasticizer provides fluidity and a VMA is used to improve the robustness of the mix and in particular is tolerance to variations in material supply such as the grading or moisture content of the fine aggregate.

There are an enormous number of publications on laboratory studies on SCC which contain details of the mix proportions, but it is more instructive when describing the possible ranges of the proportions to consider mixes which have been used in practice. The analysis of case studies of successful mixes in the period 1993 – 2003 [11] has given the medians and ranges of key mix proportions shown in table 2. The analysis showed no effect of aggregate type and size on the mix proportions, and there was also no correlation between powder content or water/powder ratio on slump flow or other fresh properties. This therefore illustrates that there is no unique mix of a given set of materials to give a particular set of fresh and hardened properties.

Table 2 also includes:

- Typical ranges of mix proportions as given in the EFNARC guidelines, which broadly correspond with those from the case study analysis, though which in some cases are a little wider. This is partly the result of the case study analysis being given in terms of the 10th and 90th centiles to avoid including exceptional mixes.
- For comparison, the proportions of a medium quality normally vibrated mix, from which the lower coarse aggregate content and higher powder and paste content of SCC are apparent.

Mix proportioning methods for SCC have two important differences from those for normally vibrated concrete:

- The dominant consideration is to produce satisfactory self-compacting properties, with less initial attention being given to the subsequent hardened properties. In particular, the self-compacting criteria will normally govern the coarse aggregate content, the paste content, the water/powder ratio and the admixture dose. Strength and other early age and long-term properties are then controlled by an appropriate combination of different

powder materials (Portland cement, fly ash, ground granulated blast furnace slag, limestone powder etc.).

- The number of possible combinations of the component materials for SCC means that a large number of variables need to be reconciled (e.g. powders, superplasticizer and viscosity agent). Since their interaction is often difficult to predict with any certainty some testing of potential combinations is necessary. The method proposed in this report uses tests on the mortar phase of the concrete for this, which is a similar approach to several other methods. Not only is this more convenient in the laboratory, enabling a wide range of variables to be readily examined, but the high mortar content of SCC results in good correlations between mortar and concrete properties and the required mortar properties are sufficiently well defined that, if achieved, the subsequent tests on concrete are minimised [13,14].

Also in common with most others, the method proposed is mainly based on considering the volumetric composition of the mix, with subsequent conversion to proportions by weight for batching.

5 The UCL method of proportioning of SCC

The method has been produced for use for powder type SCC with a coarse aggregate of 20mm or 16 mm maximum size, crushed or uncrushed. The coarse/fine aggregate division can be either 4 or 5 mm.

5.1 Test methods and equipment

Full descriptions of the test methods are included in the Appendix. The equipment available should include:

- spread and V-funnel tests for mortar (reduced scale versions of the slump flow and V-funnel tests for concrete)
- slump flow and V-funnel test for concrete, although if viscosity is not critical for the application, the t_{500} time from the slump flow test can be used as an alternative to the V-funnel flow time. The t_{500} time is approximately 3.5 times smaller than the V-funnel flow time [9].
- J-ring test, if passing ability is a requirement. This is the preferred test for passing ability in this method. If the L-Box test is to be used, then the equivalent height ratio given in Table 1 can be used.
- segregation resistance test
- mortar and concrete mixers, scales etc.

5.2 Procedure

1. Specified concrete properties

The properties required should always include slump flow; depending on the application a viscosity or passing ability or both may also be required, as discussed in section 3. Adequate segregation resistance will also be necessary, although assessment of the visual appearance and behaviour during, for example, the slump flow test may be thought sufficient. Specification in terms of the EFNARC classes (table 1), or similar, may be thought appropriate.

Some caution should however be exercised when specifying passing ability in addition to slump flow and viscosity to ensure that it is feasible to obtain a mix meeting all the class criteria. Passing ability is dependent on slump flow and viscosity as well as aggregate

bridging. The effect of the two former properties are illustrated in figure 3 which shows the variation in J-ring step height with the slump flow and V-funnel time of mixes containing a low volume (29%) of 10 mm maximum size aggregate and in which aggregate blocking therefore did not occur. The two graphs show that:

- with a 59 mm bar spacing, to achieve a step height of less than 15 mm (EFNARC class PA1) a slump flow of above 700mm and a V-funnel flow time of less than 7 seconds is required;
- with a 41 mm bar spacing, to achieve a step height of less than 15 mm (EFNARC class PA2) a slump flow of above 750mm and a V-funnel flow time of less than 4 seconds are required.

2. Materials data

Details of the materials to be used are required including:

- coarse and fine aggregate type and grading
- cement, additions and their likely combination
- the superplasticizer type
- the viscosity modifying admixture, if proposed
- the relative density of all materials.

All the materials should conform to the relevant standards for use in concrete. The aggregates, cement and additions may simply be those locally available for normally vibrated concrete production. The types and relative proportions of cement and additions will affect the strength of the concrete and/or other factors such as a heat of hydration, alkali content etc. and may therefore be chosen from previous knowledge of the materials' behaviour and the required early age and long-term properties.

3. Coarse aggregate content

All the key properties of SCC are influenced by the coarse aggregate content, and so the initial content selected will depend on the specified concrete properties. Recommend values are given in Table 3. The EFNARC class limits have been added to the table for convenience.

4. Fine aggregate content

The volume of fine aggregate (V_{fa}) is set at 45% of the resulting mortar volume, i.e.

$$V_{fa} (\%) = 0.45 (100 - V_{ca})$$

Any fine aggregate particles smaller than 0.125mm should be considered as part of the powder fraction, and therefore will not contribute to this volume. It is however, reasonable to ignore these if they constitute less than 2% of the fine aggregate.

For an air-entrained concrete, the air content can be considered as part of the mortar volume.

5. Paste volume and composition

The paste volume (V_{pa}) is then simply calculated from

$$V_{pa} (\%) = 100 - V_{ca} - V_{fa}$$

The paste composition, i.e. the water/powder ratio and the admixture dosage, is obtained from tests on mortar using the spread and V-funnel tests shown in the Appendix. The

required or target mortar properties are first obtained from the required concrete properties and the estimated coarse aggregate content using figures 4 and 5.

(If a T_{500} time has been specified for the concrete, then this should be multiplied by 3.5 to obtain the equivalent V-funnel flow time.

If no concrete V-funnel flow time has been specified, then a value of 8 seconds can be used.)

Mortars are then tested until a mix that meets the required combinations of spread and flow time is obtained. Testing a comprehensive set of mixes with varying water/powder ratios and superplasticizer contents will produce relationships such as those shown in figures 6 and 7 (but with different values and axis scales depending on the constituent materials). Transferring these on to a spread vs. V-funnel flow time chart and plotting contours of water/powder ratio and superplasticizer dose gives a diagram such figure 8. From this the water/powder ratio and superplasticizer dose for the required combination of spread and V-funnel time can be estimated.

In practice, after some experience it is not necessary to carry out tests to define the whole of this diagram, but only sufficient tests to define the area of the diagram particular interest. Variations in spread and V-funnel time for changes in mortar composition around the selected value can also be estimated from the plot, giving an indication of the likely robustness of the mix. Further explanation of the background and details of this approach can be found in Domone [15].

[Note: The effect of combinations of superplasticizer and viscosity modifying admixtures can also be investigated with the mortar tests. The same criteria can be applied to the properties of these combined type mixes as those given above]

6. Trial mixes on concrete

All of the mix proportions of the concrete have now been estimated and so a trial mix can be batched and tested. Since all of the relationships used to produce the estimates are typical or average it is almost inevitable that all of the concrete's target properties will not be obtained with the first mix; adjustments and further testing will be therefore be required. The relationships used for the initial estimates of the mix properties can be used to make the adjustments.

Table 1 SCC classes proposed by EFNARC [3]

Slump flow		Viscosity			Passing ability			Segregation resistance	
Class	Slump-flow (mm)	Class	t ₅₀₀ (secs)	V-funnel (secs)	Class	L-box height ratio	J-ring step height* (mm)	Class	sieve segregation (%)
SF1	550 to 650	VS1/ VF1	≤ 2	≤ 8	PA1	≥ 0,80 with 2 rebars	≤15 with 59mm bar spacing	SR1	≤ 20
SF2	660 to 750	VS2/ VF2	> 2	9 to 25	PA2	≥ 0,80 with 3 rebars	≤15 with 41mm bar spacing	SR2	≤ 15
SF3	760 to 850								

*J-ring step height criteria not specified by EFNARC – values have been estimated from results of Testing-SCC project

Table 2 Medians and ranges of key proportions of SCC mixes [11]

		from analysis of 68 worldwide reported case studies of SCC from 1993-2003 ¹⁰			typical ranges given by EFNARC ³	typical mid-range normally vibrated mix*
		median	10 th centile	90 th centile		
coarse aggregate (>4 or 5 mm)	% by vol	31.2	29.1	34.8	27 - 36	46
fine aggregate	% by vol	30.5	22.9	40		25
	% by wt total agg	49.5	44	54	48 - 55	35
paste (water + powders)	% by vol	34.8	32.3	39.0	30 - 38	29
powder	kg/m ³	500	445	605	380 - 600	355
free water	kg/m ³	176	161	200	150 - 210	160
water/powder ratio	by wt	0.34	0.28	0.42		0.45
	by vol	1.03	0.83	1.28	0.85 – 1.10	1.41
* 40MPa char. cube strength, 75 mm slump, 20mm gravel aggregate, CEM I, typical superplasticizer dose						

Table 3 Recommended values of coarse aggregate (max size 16 or 20mm) content for initial mixes

specified properties (<i>EFNARC class</i>)				initial coarse aggregate % by volume (V_{ca})
slump flow	viscosity: V-funnel flow time	passing ability: J-ring step height		
		59mm bar spacing	41mm bar spacing	
any (SF1, SF2, SF3)	not specified	not specified		38
any (SF1, SF2, SF3)	≤ 8 secs (<i>VF1</i>)	not specified		30
	>8 and ≤ 15 (<i>VF2</i>)			35
	> 15 secs (<i>VF2</i>)			38
< 700 (SF1/SF2)	≤ 8 secs (<i>VF2</i>)*	<15 mm (<i>PA1</i>)		no mix possible
700-750mm (SF2)				34
> 750 (SF3)				38
< 700 (SF1/SF2)	≤ 4 secs (<i>VF1</i>)*		<15 mm (<i>PA2</i>)	no mix possible
700-800mm (SF2/SF3)				32
>800 (SF3)				35

*max recommended values for mixes with a PA1 or PA2 passing ability requirement

V-funnel flow time	EFNARC class			
9-25 secs	VF2	ramps		tall and slender elements
5-9 secs	VF1		walls	
3-5 secs	VF1	floors		
slump flow		470-570 mm	540-660 mm	630-800 mm
EFNARC class		-	SF1	SF2/SF3

Figure 1 Applications for SCC of different properties (adapted from Walraven [2])

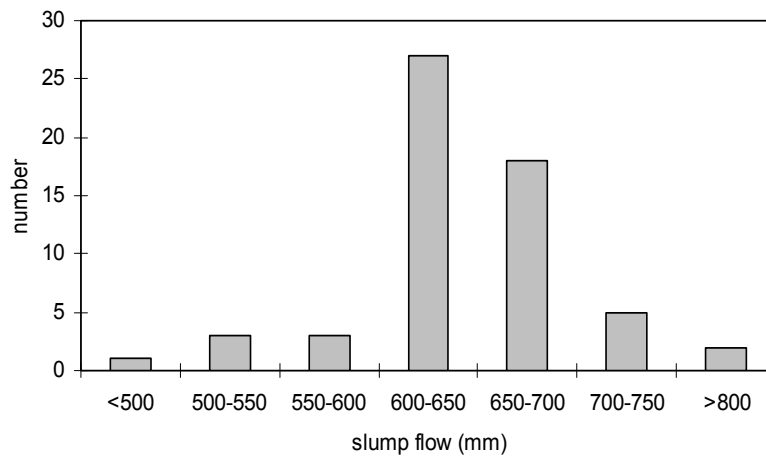
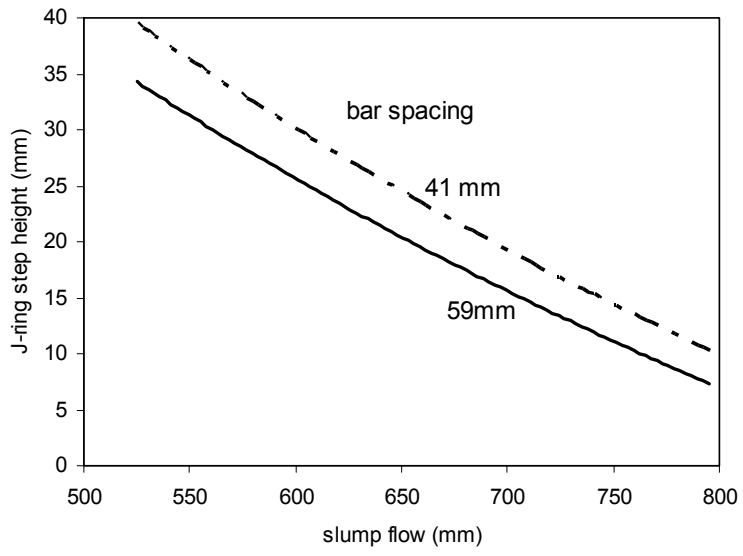
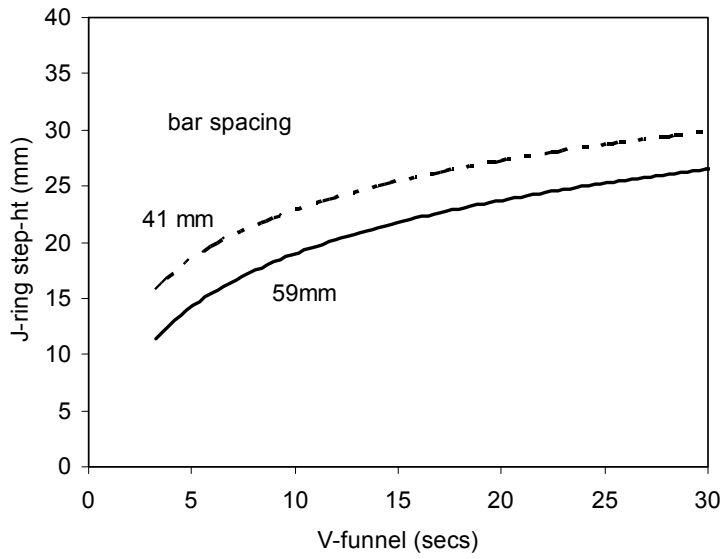

Figure 2 Slump flow values from an analysis of 68 worldwide case studies of applications of SCC (from Domone [11])



(a)



(b)

Figure 3 The effect of (a) slump flow and (b) V-Funnel flow time on the J-ring step height for mixes with no aggregate bridging (UCL data)

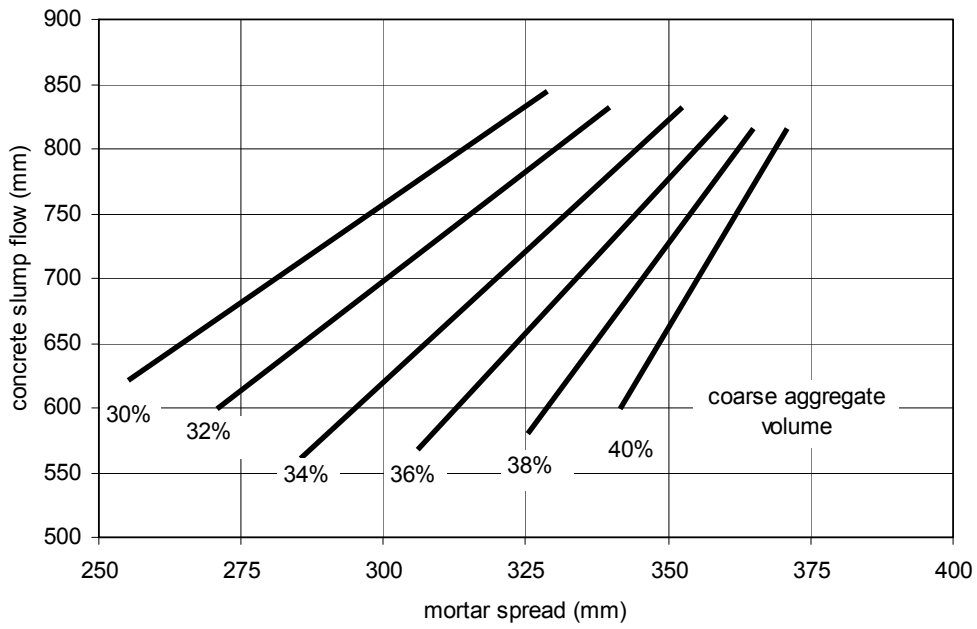

Figure 4 Mortar spread values for concrete slump flow and coarse aggregate contents (from UCL data)

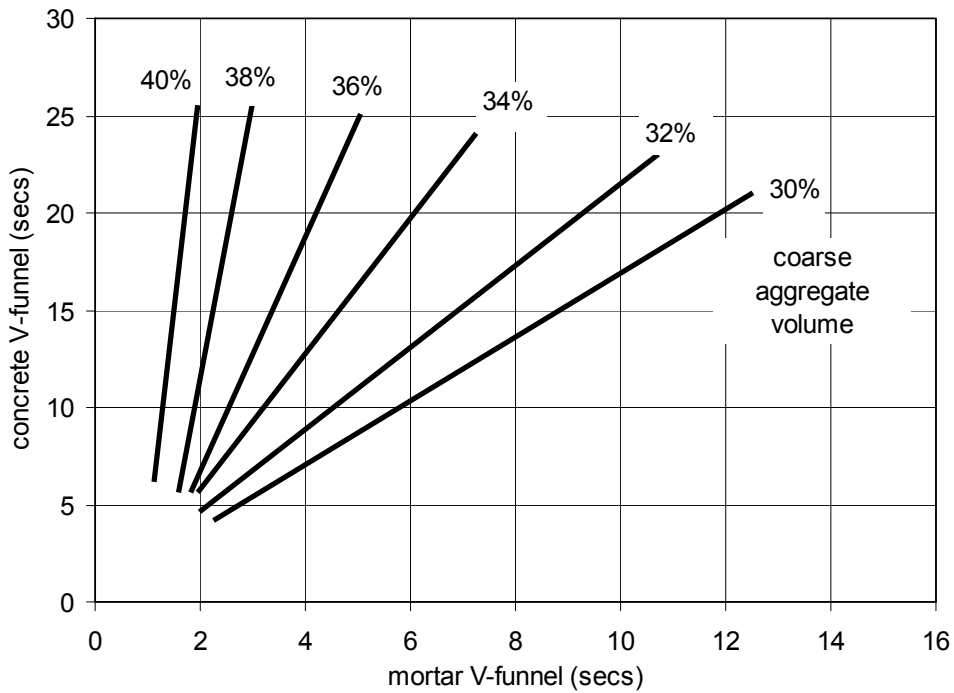

Figure 5 Mortar V-funnel values for concrete V-funnel and coarse aggregate contents (from UCL data)

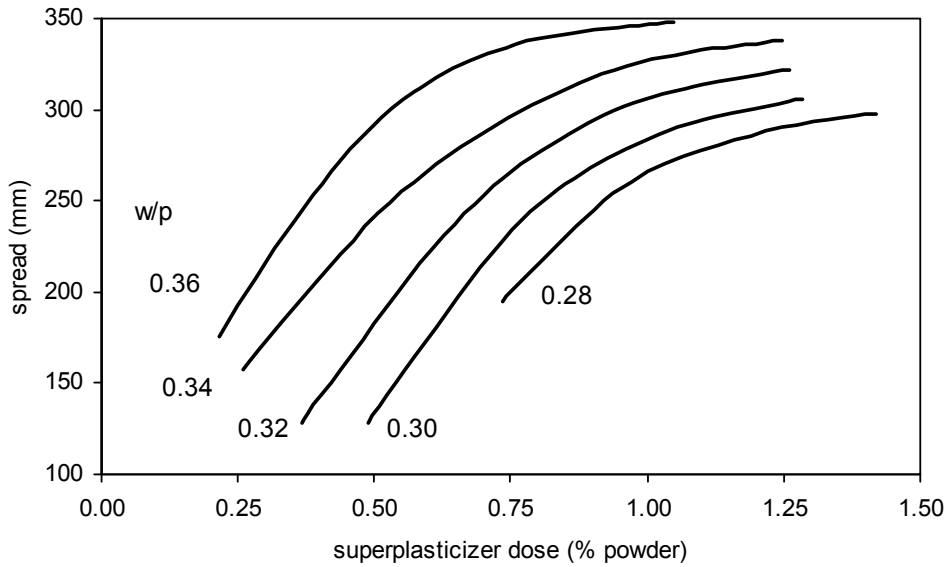

Figure 6 Typical relationships between superplasticizer dose, water/powder ratio and mortar spread (adapted from Domone [15])

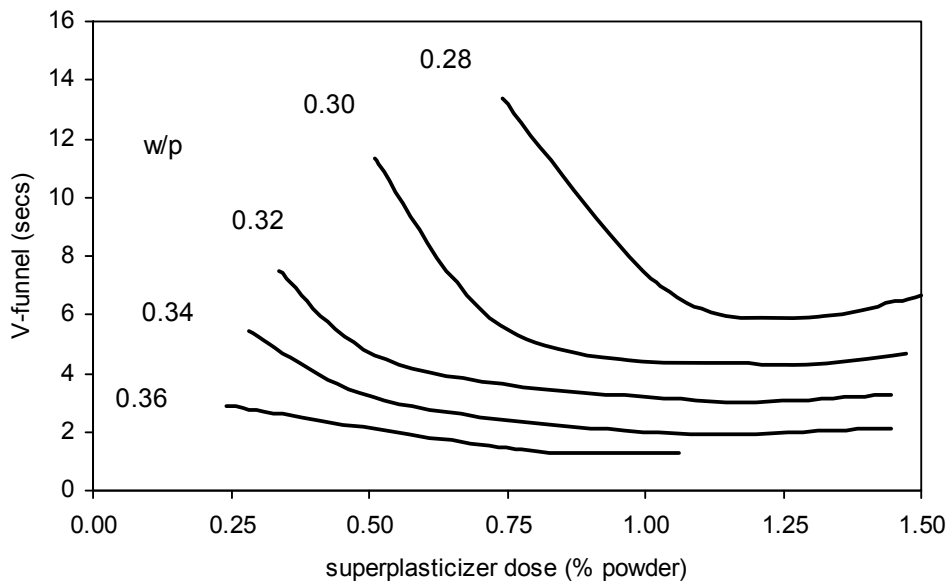

Figure 7 Typical relationships between superplasticizer dose, water/powder ratio and mortar V-funnel flow time (adapted from Domone [15])

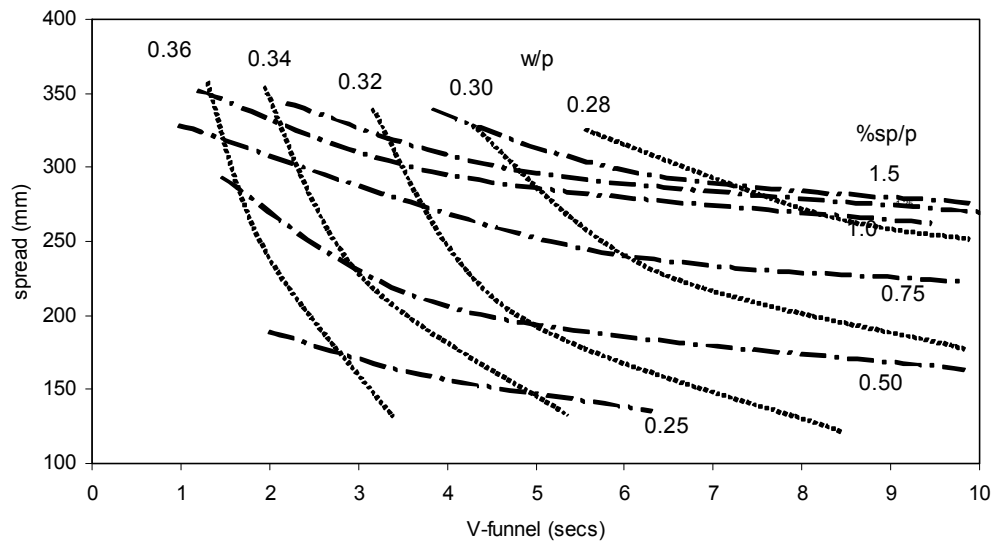

Figure 8 A typical mortar spread – V-funnel flow time diagram showing the effect of water/powder ratio and superplasticizer dose (adapted from Domone [15])

Appendix A Tests for mortar

A1. Spread

The spread test assesses the free, unrestricted deformability of the mortar fraction of SCC.

Equipment

The test requires a truncated metal cone with the internal dimensions shown in figure 1.1. The overall dimensions should be such that the cone remains in position during filling by its self weight alone (see figure 1.2).

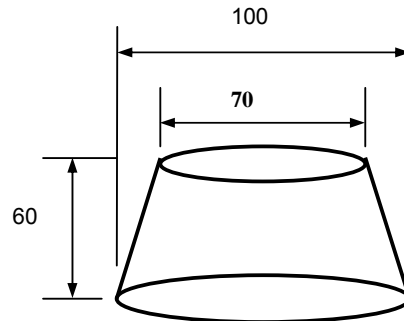

Figure A1.1 Internal dimensions of the test cone

The test should be carried out on a toughened glass plate approx. 500mm square, backed by concentric measuring rings if thought useful (see figure 1.2).

The following are also required:

- a beaker or similar with a pouring lip (the mortar mixing bowl may be suitable)
- moist cleaning mop or rag
- straight edge to level concrete above cone
- ruler (graduated in mm) and two blocks made of wood, plastic, or metal

Procedure

1. Prewet the surface of the metal cone and the glass plate with water and remove the surplus with the cleaning rag.
2. Place the plate in a stable position on the flat and horizontal ground.
3. Place the cone in the centre of the plate
4. Fill the cone with a representative sample of mortar by pouring from the beaker without any external compaction such as rodding or vibrating.
5. Strike-off level any mortar above the top of the cone
6. Remove any spilled mortar from the plate.
7. Lift the cone from the plate in a single smooth action of 1-2 secs
8. Allow the mortar to spread without any external disturbance until it comes to rest.
9. Measure the diameter of the mortar in two perpendicular directions to the nearest 2mm.
10. Note if any rim of bleed water has appeared at the edge of the mortar, and if so measure its width.

Test report

The following results should be reported:

- the two spread diameters and the SPREAD (nearest 2mm)
- the absence or presence of a rim of bleed water
- If present the average width of the rim

Fig A1.2 Filling the truncated metal cone



Fig A1.3 Lifting the cone



Fig A1.4 Measuring the spread



Appendix A Tests for mortar

A2. V-funnel

The test measures the flow rate of mortar through the orifice under self-weight, and the flow time is an indication of its plastic viscosity

Equipment

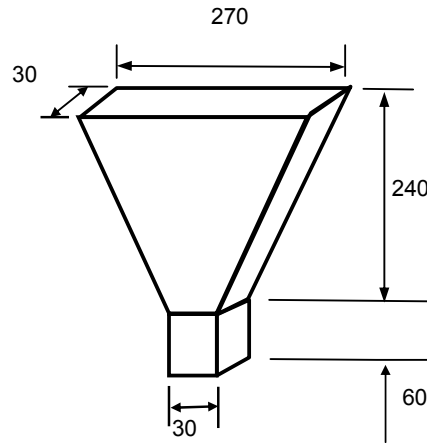

Figure A2.1. Dimensions of V-funnel test for mortar

To measure the V-funnel flow-time the following equipment is required:

- V-funnel with the internal dimensions shown in Fig. A2.1, made of steel, with a flat, horizontal top and placed on vertical supports, and with a quickly releasable, watertight opening trapdoor
- straightedge to level mortar
- clean, wetted and squeezed towel or cloth
- stopwatch (accuracy: 0.1 s)
- bucket with a capacity of 1.5 litres

Test procedure and data recording

1. Place the clean V-funnel vertically on a flat, firm ground, with the top opening horizontal. Wet the interior of the funnel with a moistened towel so that it is 'just wet'.
2. Close the trapdoor and position the bucket below it.
3. Fill the funnel completely with a representative sample of the mortar SCC without applying any compaction or rodding. Strike off any surplus mortar. Do not knock or move the V-funnel until it is empty.
4. Open the trapdoor and simultaneously start the stopwatch. Look vertically down inside the funnel, and stop the time at the instant that daylight can be seen through the opening. This is the **flow-time**.
5. Repeat operation two more times using the same sample and without any cleaning between tests. Record the flow-times from the second and the third runs.
6. The funnel should be cleaned after testing is complete.

Test report

The following results should be reported:

- Each single flow time and the average value, to the nearest 0.1 secs
- Visual observations of any temporary or complete stop of the flow



Fig A2.2 Filling the mortar V-funnel



Fig A2.3 Measuring the flow time

Appendix B Tests for concrete

B1. Slump flow and flow-time T_{500}

Principle

The slump flow test aims at investigating the free, unrestricted deformability of SCC. The flow-time T_{500} indicates the rate of deformation within a defined flow distance.

Equipment

Fig. B1.1 shows the dimensions of a truncated cone, the base plate with metal cover and the prescribed circle of 500 mm.

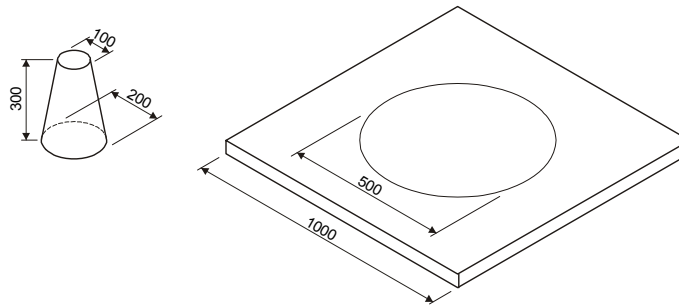

Fig. B1.1 Test set-up slump flow test with a prescribed circle of 500 mm.

To carry out the slump flow test (and to measure T_{500}) the following equipment is required:

- base plate (at least 900×900 mm), plain and smooth, covered with a metal layer (with prescribed circles of 500 mm around centre of the plate), watertight and stiff
- metal slump cone (upper/lower diameter 100/200 mm, height 300 mm)
- wetted cleaning mop or rag
- straight edge to level concrete above cone
- stopwatch (accuracy: 0.1 s)
- ruler (graduated in mm) and two blocks made of wood, plastic, or metal

Preparation of the test

1. Prewet the surface of the plate with water and remove the surplus either by a cleaning rag or by placing the plate vertically.
2. Place the cleaned base plate in a stable position on the flat and horizontal ground.
3. Place the cone (interior moistured with a wet rag) in the center of the base plate and hold the cone firmly to keep it in place.
4. Fill the cone with the representative sample from the concrete batch without any external compaction such as rodding or vibrating. The surplus of concrete above the top of the cone should be struck-off level and any remaining concrete removed from the plate.
5. If necessary, wet the surface of the plate again with the moist towel. No dry area on the base plate is allowed and any surplus of the water has to be removed – the moisture state of the plate has to be 'just wet'.

Execution of the test and data recording

1. Lift the cone in a single vertical movement, so that the concrete is allowed to flow out freely without obstruction from the cone.
2. Start the stopwatch at the same moment as the cone leaves the plate. Stop the stopwatch when the flow front of the concrete first passes the prescribed circle of 500 mm (for T_{500}).
3. The test ends when the flow of SCC stopped. Do not knock or touch the plate until the measurement of the diameters is completed.
4. The largest diameter of the flow spread, d_{max} , and the one perpendicular to it, d_{perp} , are measured using the ruler (reading to mm) with the help of two blocks.
5. After testing, clean the plate and cone.

Expression of the results

From the slump flow test the following data could be derived:

- Slump flow [mm]: The slump flow S is the average of diameters d_{max} and d_{perp} (rounded to the nearest 5 mm).

$$S = \frac{(d_{max} + d_{perp})}{2}$$

- Flow time T_{500} [sec]: The flow time is the period between the moments the cone leaves the plate and SCC first passes the prescribed circle of 500 mm (rounded to the nearest 1/10 s).
- Visual observations: In order to decide whether SCC is susceptible to segregation the following observations should be recorded.
 - Colour variation of the cement paste (either in the mixer or after executing the slump flow test)
 - Uneven distribution of aggregates (along the flow or clustering of aggregates in the center of the bottom plate)
 - Cement paste halo (without any coarse aggregates)

Test report

The following results should be reported:

- Spread diameters d_{max} and d_{perp} , and slump flow S
- Flow time T_{500}
- Visual observations if SCC is not homogenous

Appendix B Tests for concrete

B2. V-funnel flow-time

Principle

The V-funnel flow-time is the time for a defined volume of SCC to flow through a narrow opening at the mouth of the funnel and gives an indication of the filling ability of SCC provided blocking and/or segregation do not take place; the flow-time of the V-funnel test is to some degree related to the plastic viscosity.

Equipment

Fig. B2.1 shows the dimensions of the V-funnel. The flow-time depends on the volume of SCC, the size of the opening gap and whether other key characteristics of SCC than filling ability affect the test response.

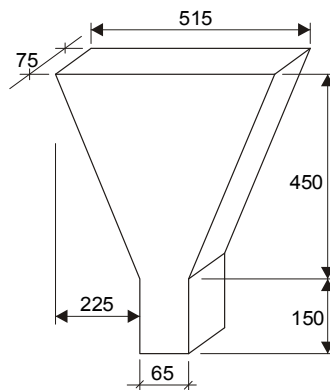

Fig. B2.1 Dimensions of the V-funnel.

To measure the V-funnel flow-time the following equipment is required:

- V-funnel made of steel, with a flat, horizontal top and placed on vertical supports, and with a quickly releasable, watertight opening trapdoor
- straightedge to level concrete
- clean, wetted and squeezed towel or cloth
- stopwatch (accuracy: 0.1 s)
- bucket with a capacity of 12 litres

Preparation of the test

1. Place the clean V-funnel vertically on a flat, firm ground, with the top opening horizontal.
2. Wet the interior of the funnel with a moistened towel; surplus water must be removed; the inside of the funnel has to be 'just wet'.
3. Close the trapdoor and position the bucket below it.
4. Fill the funnel completely with a representative sample of SCC without applying any compaction or rodding.
5. Strike off any surplus of concrete. Do not knock or move the V-funnel until it is empty.

Execution of the test and data processing

1. 10 seconds after completing the filling, open the trapdoor.
2. Start the stopwatch at the same moment as the gate opens.
3. Look vertically inside the funnel, and stop the time at the instant that daylight can be seen through the opening.

The above operation shall be carried out three times using the same sample and without any cleaning between tests. The flow-times from the second and the third running shall be recorded.

The funnel should be cleaned after testing is complete.

Expression of results

Two results can be arrived from the V-funnel test: flow-time and visual observations.

Flow-time: The flow-time is the period from releasing the gate until first light enters the opening gap. Round the flow time to the nearest 1/10 s.

Visual observations: Any temporary or complete stop of the flow might indicate instability of SCC.

Test report

The following results should be reported:

- Each single flow time and the average value
- Visual observations if any temporary or complete stop

Appendix B Tests for concrete

B3. J-Ring

Principle

The J-ring test investigates the blocking behaviour of SCC. It simulates the flow of concrete through reinforcing bars.

In this test the blocking behaviour can be quantified by the concrete spread diameter S_J and the step-height st_J which is defined as the height difference, Δh , of the concrete surface inside and outside the J-ring bars (Figs. B3.1 and B3.2). The flow time $T50_J$ can also be measured which indicates the rate of deformation within a defined flow distance and a defined obstacle.

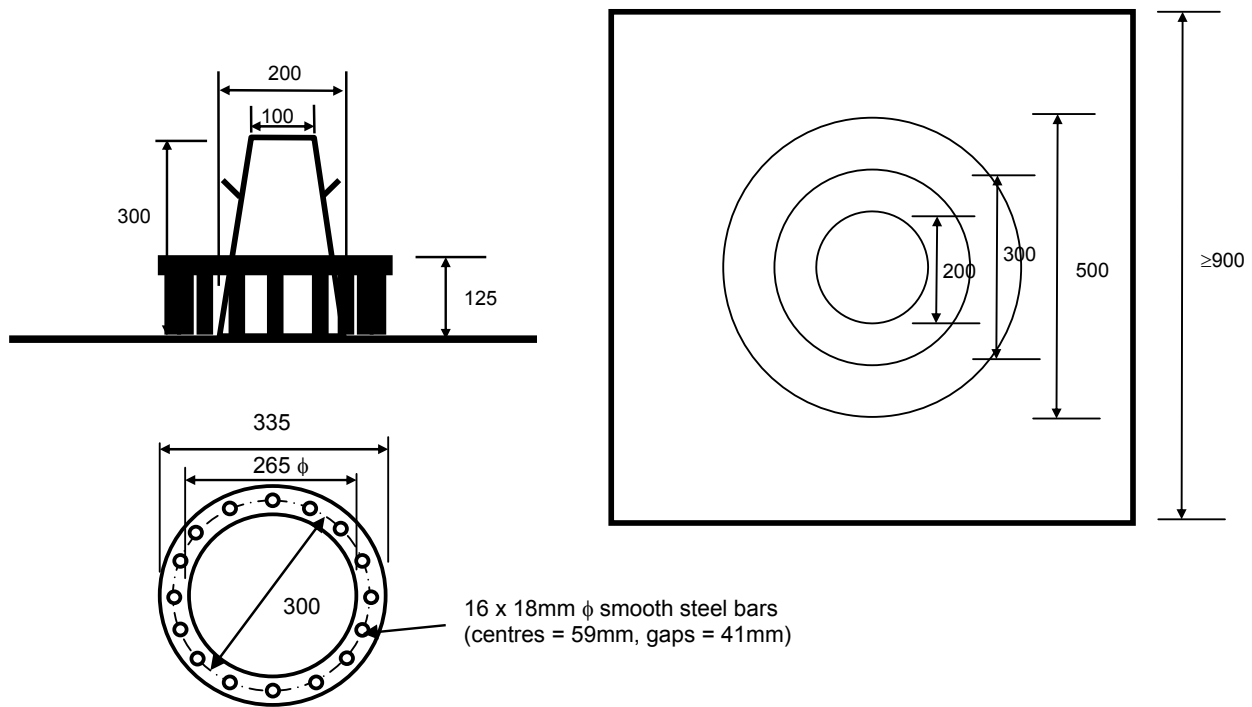

Fig B3.1 J-ring test set-up and dimensions

Equipment

The following equipment is required:

- base plate (at least 900 × 900 mm), plain and smooth, covered with a metal layer (with a prescribed circle of 500 mm ($T50_J$), watertight and stiff)
- J-ring (dimensions as in Fig. 4.1)
- metal slump cone (upper/lower diameter 100/200 mm, height 300 mm)
- cleaning rag
- a straight rod (preferably made of metal, wood or polymer) with a length of about 400 mm, and at least one flat side
- clean, wetted and squeezed towel or cloth
- stopwatch (accuracy: 0.1 s)
- ruler (graduated in mm) and two blocks made of wood, plastic or metal

Fig. B3.1 shows the base plate, the slump cone (just before being placed on the base plate) and the J-ring with 16 smooth steel rods of $\text{Ø}18$ mm (for a maximum aggregate size 16 to 22 mm).

Preparation of the test

1. Prewet the surface of the plate with water and remove the surplus either by a cleaning rag or by placing the plate vertically.
2. Ensure that the cleaned base plate is on stable and horizontal ground. Place the J-ring and the cone (with interior moistened with a moist towel) in the center of the base plate and hold push the cone firmly to keep it in place.
3. Fill the cone with the representative sample from the concrete batch without any external compact action such as rodding or vibrating. Care should be taken to avoid concrete from dropping outside the cone, but any concrete that does fall outside must be removed immediately to prevent any influence on the blocking behaviour.
4. If necessary, wet the surface of the plate again with the moist towel. No dry area on the base plate is allowed and any surplus of the water has to be removed – the moisture state of the plate has to be 'just wet'.

Execution of the test and data recording

1. Lift up the cone perpendicular to the base plate in a single movement such that that concrete is allowed to flow out freely without obstruction or lifting by the cone
2. Start the stopwatch at the same moment the cone leaves the plate. Stop the stopwatch when the flow front of the concrete first passes the 500 mm diameter inscribed circle. The elapsed time (to the nearest 0.1 secs) is the T_{50} time.
3. The test finishes when concrete stops flowing. Do not knock or touch the baseplate or otherwise touch the concrete until all the measurements have been completed.
4. Lay the straight rod with the flat side on the J-ring and measure the relative height differences between the lower edge of the straight rod and the concrete surface at three points (as shown in Fig. B3.2), in two directions at right angles i.e. a total of one measurement in the centre of the ring and four measurements just outside it. For non-circular concrete spreads the first direction should be parallel to the largest spread diameter.
5. Measure the largest diameter of the concrete and the one perpendicular to this with the metre rule, to the nearest mm, with the help of the two guide blocks.

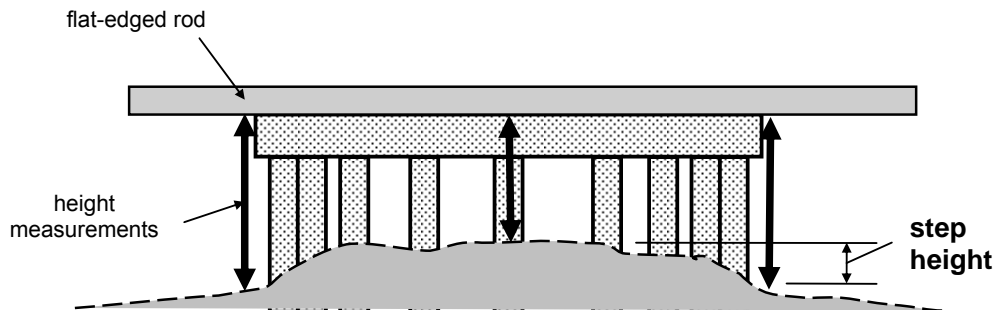

Figure B3.2 J-ring measurement for step-height

Expression of results

Step-height: the difference between the average of the four measurements outside the ring and the measurement inside the ring.

Flow time T_{50} : the time from the moment the cone leaves the board and the SCC first passing the 500 mm diameter inscribed circle, rounded to the nearest 0.1 s.

Average slump flow diameter: the average of the two diameters, rounded to the nearest 5 mm.

Test report

The following results should be reported:

- step-height
- flow time
- average slump flow diameter

Appendix B Tests for concrete

B4. L-Box

Principle

The method covers evaluation of passing ability of self-compacting concrete. It is possible to measure properties such as blocking behaviour, with a visual indication of flowability and segregation.

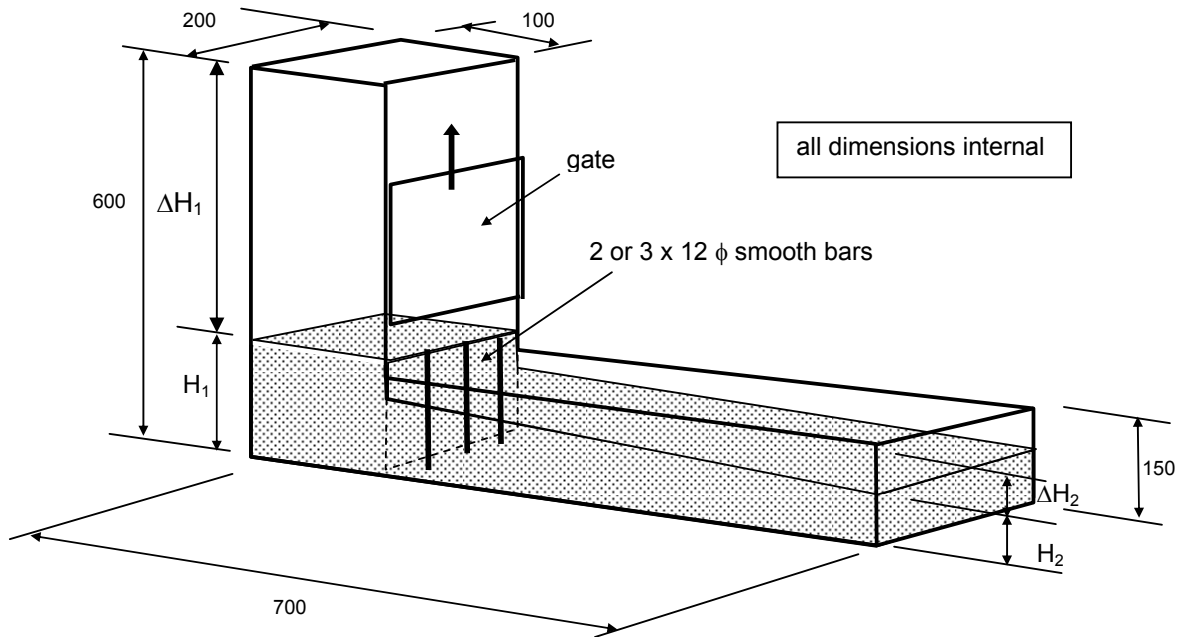

Fig B4.1 L-box test set-up

Equipment

The principle of the L- box is shown in Fig. B4.1. Two types of obstacles can be used, one with 3 smooth bars and one with 2 smooth bars. The gaps are 41 and 59 mm respectively. The type with 3 smooth bars is more commonly used.

Execution of the test

1. The vertical part of the box, with the extra adapter mounted, is filled with 12.7 litres of concrete.
2. The concrete is allowed to rest for one minute. During this time the concrete will show whether it is stable or not (i.e. any tendency to segregation).
3. Lift the sliding gate. The concrete will now flow out of the vertical part into the horizontal part of the L-box. passing obstacle of bars.

Data recording

When the concrete has stopped, remove the adapter and measure ΔH_1 (mm) in 3 places and ΔH_2 (mm) in 3 places.

Both blocking and stability can be detected visually. If the concrete builds a plateau behind the reinforcement layer, the concrete has either blocked or segregated. Usually blocking is

indicated by gathered coarse aggregates between the reinforcement bars. If coarser aggregates are distributed on the concrete surface all the way to the end of the horizontal part, the concrete can be regarded as stable.

Expression of the results

The blocking ratio is calculated from the following expression:

$$BR = H_2 / H_1$$

$$\text{where } H_1 = 600 - \frac{1}{3} \sum_{i=1}^3 \Delta h_{1i} \text{ (mm) and } H_2 = 150 - \frac{1}{3} \sum_{i=1}^3 \Delta h_{2i} \text{ (mm).}$$

Test report

The following results should be reported:

- All the measured values of Δh_{1i} and Δh_{2i}
- The calculated values of H_1 and H_2
- The blocking ratio BR

Appendix B Tests for concrete

B5. Segregation - Sieve stability

Principle

The test aims at investigating the resistance of self-compacting concrete to segregation.

Equipment

- 10 L bucket + lid (see Fig. B5.1)
- 5 mm sieve (perforated plate sieve, square holes, EN 12620) 300 mm or 315 mm diameter + pan
- scale – accurate to within 20 g, minimum range 20 kg.

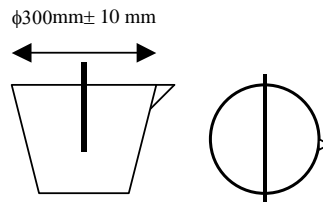

Fig. B5.1 Bucket used in the segregation test.

Test procedure and data recording

1. Place the bucket on a flat, level and firm surface (or in the bucket holder if available (fig B5.2)).
2. Pour 10 litres of concrete directly into the bucket. The waiting time between stopping the mixer and sampling the concrete should be less than 30s and all care should be taken to ensure that the sample is representative. Cover the bucket to prevent the concrete drying out.
3. 15 min after filling of the bucket, inspect the surface of the bucket for clear bleed water and record it if there is any.
4. Weigh the pan alone, noted as W_{pan} , and place the sieve + pan on the scales.
5. Zero the scale.
6. Pour 4.8 kg of concrete (± 0.2 kg) onto the sieve; pour it onto the centre of the sieve from a height of 50 ± 5 cm.
7. Record the weight of the sample, W_{sample} .
8. Two minutes after sampling, zero the scale and weigh the pan with the laitance, noted as $W_{\text{pan+laitance}}$.

Segregation index π : the percentage of laitance by weight of the sample is defined as the segregation index, that is,

$$\pi = \frac{W_{\text{laitance}}}{W_{\text{sample}}} \times 100$$

$$\text{where } W_{\text{laitance}} = W_{\text{pan+laitance}} - W_{\text{pan}}$$

Test report

The following results should be reported:

- All the measured values of weight
- The calculated segregation index π
- Visual observations and record of any bleeding water from the concrete



Figure B5.2. Bucket holder and pouring system

References

- 1 De Schutter G, Bartos P J M, Domone P and Gibbs J *Self-compacting Concrete*, Whittles Publishing, Caithness, Scotland, 2008
- 2 Walraven J Structural applications of self compacting concrete *Proceedings of 3rd RILEM International Symposium on Self Compacting Concrete*, Reykjavik, Iceland, ed. Wallevik O and Nielsson I, RILEM Publications PRO 33, Bagnaux, France, August 2003 pp 15-22
- 3 EFNARC European Project Group *The European Guidelines for Self-Compacting Concrete: Specification, Production and Use* May 2005 <http://www.efnarc.org/pdf/SCCGuidelinesMay2005.pdf>
- 4 EN 12350-8 *Testing fresh concrete- Part 8: Self-compacting concrete – Slump-flow test*
- 5 EN 12350-9 *Testing fresh concrete- Part 9: Self-compacting concrete – V-funnel test*
- 6 EN 12350-10 *Testing fresh concrete- Part 10: Self-compacting concrete – L-box test*
- 7 EN 12350-11 *Testing fresh concrete- Part 11: Self-compacting concrete – Sieve segregation test*
- 8 EN 12350-12 *Testing fresh concrete- Part 12: Self-compacting concrete – J-ring test*
- 9 Bartos P (project coordinator) European Union Growth Contract No. G6RD-CT-2001-00580 *Testing-SCC: Measurement of properties of fresh self-compacting concrete Final Report September 2005* <http://www.civeng.ucl.ac.uk/research/concrete/Testing-SCC/>
- 10 ACI Committee 237 *Self-consolidating concrete* ACI Report 237R-07, American Concrete Institute Michigan USA, April 2007
- 11 Domone P L Self-compacting concrete; An analysis of 11 years of case studies *Cement and Concrete Composites* 28, 2, February 2006 pp 197-208
- 12 Okamura H, Ozawa K. Mix design method for self-compacting concrete *Concrete Library of Japan Society of Civil Engineers* No 25, June 1995 pp107-120
- 13 Domone P L and Jin J, Properties of mortar for self-compacting concrete. *Proceedings of RILEM International Symposium on Self-Compacting Concrete*, Stockholm, September 1999, ed, Skarendal A and Petersson O, RILEM Proceedings PRO7, Paris 109-120
- 14 Jin J and Domone P L Relationships between the fresh properties of scc and its mortar component *Proceedings of the First North American Conference on the Design and Use of Self-Consolidating Concrete, Centre for Advanced Cement Based Materials*, North Western University, Chicago, November 2002, pp 33-38
- 15 Domone P L Mortar tests for material selection and mix design of SCC, *Concrete International*, 28, 4, April 2006 pp 39 – 45